



- (51) International Patent Classification:
B02C 4/32 (2006.01)
- (21) International Application Number:
PCT/US2013/034068
- (22) International Filing Date:
27 March 2013 (27.03.2013)
- (25) Filing Language: English
- (26) Publication Language: English
- (30) Priority Data:
13/469,169 11 May 2012 (11.05.2012) US
- (71) Applicant: METSO MINERALS INDUSTRIES, INC.
[US/US]; 20965 Crossroads Circle, Waukesha, WI 53186 (US).
- (72) Inventor: CROYLE, Robert, C.; 2222 Millerstown Road, Shippenville, PA 16254 (US).
- (74) Agents: KUBORN, Joseph, D. et al.; Andrus, Sceales, Starke & Sawall, LLP, 100 East Wisconsin Avenue, Suite 1100, Milwaukee, WI 53202-4178 (US).

- (81) Designated States (unless otherwise indicated, for every kind of national protection available): AE, AG, AL, AM, AO, AT, AU, AZ, BA, BB, BG, BH, BN, BR, BW, BY, BZ, CA, CH, CL, CN, CO, CR, CU, CZ, DE, DK, DM, DO, DZ, EC, EE, EG, ES, FI, GB, GD, GE, GH, GM, GT, HN, HR, HU, ID, IL, IN, IS, JP, KE, KG, KM, KN, KP, KR, KZ, LA, LC, LK, LR, LS, LT, LU, LY, MA, MD, ME, MG, MK, MN, MW, MX, MY, MZ, NA, NG, NI, NO, NZ, OM, PA, PE, PG, PH, PL, PT, QA, RO, RS, RU, RW, SC, SD, SE, SG, SK, SL, SM, ST, SV, SY, TH, TJ, TM, TN, TR, TT, TZ, UA, UG, US, UZ, VC, VN, ZA, ZM, ZW.
- (84) Designated States (unless otherwise indicated, for every kind of regional protection available): ARIPO (BW, GH, GM, KE, LR, LS, MW, MZ, NA, RW, SD, SL, SZ, TZ, UG, ZM, ZW), Eurasian (AM, AZ, BY, KG, KZ, RU, TJ, TM), European (AL, AT, BE, BG, CH, CY, CZ, DE, DK, EE, ES, FI, FR, GB, GR, HR, HU, IE, IS, IT, LT, LU, LV, MC, MK, MT, NL, NO, PL, PT, RO, RS, SE, SI, SK, SM, TR), OAPI (BF, BJ, CF, CG, CI, CM, GA, GN, GQ, GW, ML, MR, NE, SN, TD, TG).

[Continued on next page]

(54) Title: HANDLING APPARATUS AND METHODS FOR HANDLING A ROLLER OF A ROLLER CRUSHER

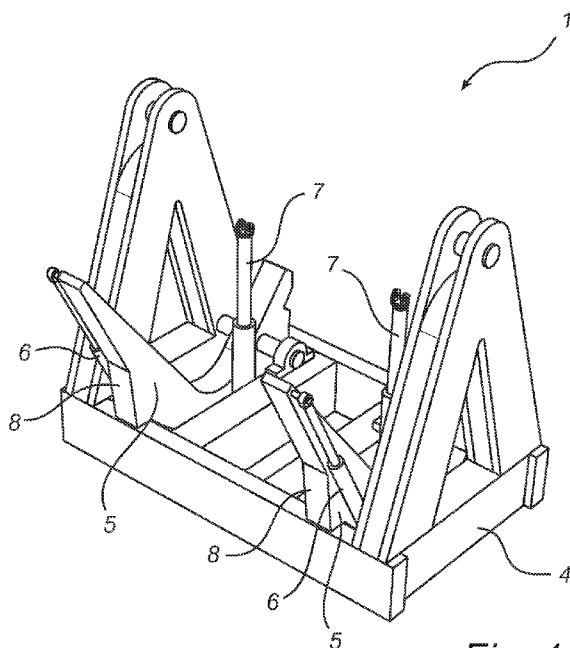

Fig. 1

(57) Abstract: The invention relates to a handling apparatus for handling a roller of a roller crusher. The handling apparatus comprises a movable base, a carrier pivotably attached to said base and adapted to carry the roller, at least one carrier pivoting device pivotably attached to said base and attached to said carrier, said carrier pivoting device being extendable, and at least one roller pivoting device pivotably connected to said base, said roller pivoting device being adapted to releasably engage said roller. The invention also relates to a method for mounting a roller to a roller crusher and a method for dismounting a roller to a roller crusher.



Published:

— *with international search report (Art. 21(3))*

HANDLING APPARATUS AND METHODS FOR HANDLING A ROLLER OF
A ROLLER CRUSHER

Technical field

The present disclosure relates to a handling apparatus for handling a roller of a roller crusher. Further, the present disclosure relates to a method for mounting a roller to a roller crusher and a method for dismounting a roller
5 from a roller crusher.

Background art

When crushing or grinding rock, ore, cement clinker and other hard materials, roller crushers may be used having two generally parallel rolls
10 which rotate in opposite directions, towards each other, and which are separated by a gap. The material to be crushed is fed by gravity or choke-fed into the gap. One type of roller crusher is called high pressure grinding rollers or high pressure roller crushers. This type of roller crusher uses a crushing technique called interparticle crushing. Here, the material to be crushed or
15 pulverised is crushed, not only by the crushing surface of the rolls, but also by particles in the material to be crushed, hence the name interparticle crushing. One example of a high pressure grinding roller is described in EP-516 952.

The rollers of the roller crusher is exposed to a very high pressure and accordingly for extreme wear from the material to be crushed. When the roller
20 surface is worn to a certain extent, the roller must be dismantled to be reconditioned or replaced. This dismantling operation is difficult to execute at the installation place of the equipment, in most cases requiring the whole assembly formed by the shaft, crushing shell, end bearings and respective bearing housings to be removed from the equipment and transported to a
25 place in which the reconditioning or replacement of the crushing surface and, eventually, of the bearings, can be adequately and safely carried out. The subsequent mounting is equally complicated.

Taking into account that the assembly defined by each of the rollers and respective bearings and bearing housings represents a large weight,
30 corresponding to a preponderant part of the weight of the equipment as a

whole, the operations of dismounting, carrying and remounting the roller assemblies require special cares, which are complex, time-consuming and, consequently, expensive.

5 Summary

The present disclosure provides a handling apparatus which allows a simple, fast and safe mounting and dismounting of a roller to and from a roller crusher. Further, it is a feature of the present disclosure to provide a method for mounting a roller to a roller crusher and a method for dismounting a roller
10 from a roller crusher.

These and other features and advantages that will be apparent from the following description of the present disclosure are achieved by a handling apparatus for a grinding roll for heavy wear operation according to the following features.

15 Thus, a handling apparatus for handling a roller of a roller crusher is provided. The handling apparatus comprises a movable base, a carrier pivotably attached to said base and adapted to carry a roller, at least one carrier pivoting device pivotably attached to said base and attached to said carrier, said carrier pivoting device being extendable, and at least one roller
20 pivoting device pivotably connected to said base, said roller pivoting device being adapted to releasably engage said roller. This is advantageous in that the roller can be dismounted from and later on mounted back onto the roller crusher in a safe and simple manner. The handling apparatus makes the handling of rollers automatic and time efficient, and consequently cost
25 efficient. The handling apparatus can be used both for dismounting and mounting of rollers, but also for transport of rollers away from the roller crusher for replacement or conditioning and back to the roller crusher for subsequent mounting. During use, the handling apparatus is transported to the roller crusher and placed parallel to the roller to be dismounted. The
30 carrier is then arranged in connection with the roller crusher by means of the carrier pivoting device such that the roller pivoting device can engage the roller and guide it onto the handling device in two steps. Thereafter, the roller can be transported away from the roller crusher for replacement or

conditioning. The opposite procedure is implemented in order to mount the roller back onto the roller crusher.

The roller pivoting device may be extendable, which makes it more flexible in relation to the roller to be mounted or dismounted.

5 The carrier may comprise a support member adapted to rest against said base for support. The support member will increase the stability of the handling device, especially when it carries a roller.

The carrier may have a shape conforming to an outer shape of a bearing housing, which shape may be a triangular shape. The carrier will thus
10 be adapted to receive a bearing housing having a triangular shape, which is a preferred embodiment.

The carrier may have power drive in order to rotate over its pivot point, which is advantageous in that the carrier will be more flexible in relation to the base.

15 The carrier may be adjustable to be able to accept different types of rollers or bearing housings. Naturally, this will make the carrier suitable for all types of rollers and bearing housings.

The base may be adapted to be lifted by a lifting machine and may comprise power drive in order to move along a ground, which makes the
20 handling apparatus movable to a greater extent.

The carrier pivoting device may pivotably attached to said carrier in order to increase the movability of the apparatus.

The roller pivoting device may be pivotably attached to said carrier. When the roller pivoting device is attached directly to the carrier, it will be
25 positioned in relation to the roller by means of the movement of the carrier, thereby simplifying the operation.

The roller pivoting device may be adapted to releasably engage a bearing housing of said roller. In some roller crushers, the roller is held by a bearing housing which naturally can be dismounted together with the roller by
30 means of the handling apparatus. Here, the roller pivoting device engages the bearing housing holding the roller instead of the roller itself directly.

According to a second aspect of the disclosure, a method for mounting a roller to a roller crusher is provided. The method comprises transporting a

base having a carrier carrying the roller to said roller crusher, pivoting said carrier a first angle towards said roller crusher, pivotably attaching said roller to a first attachment point of said roller crusher, pivoting said roller a second angle towards said roller crusher, and attaching said roller to a second
5 attachment point of said roller crusher.

According to a third aspect of the disclosure, a method for dismounting a roller to a roller crusher is provided. The method comprises detaching said roller from a second attachment point of said roller crusher, pivoting said roller a second angle away from said roller crusher, detaching said roller from a first
10 attachment point of said roller crusher, pivoting a carrier carrying the roller a first angle away from said roller crusher onto a base, transporting said base away from said roller crusher.

The methods are advantageous in that the roller can be dismounted from and later on mounted back onto the roller crusher in a safe and simple
15 manner. The handling of rollers is made time efficient, and consequently cost efficient.

Generally, all terms used in the following are to be interpreted according to their ordinary meaning in the technical field, unless explicitly defined otherwise herein. All references to "a/an/the [element, device,
20 component, means, step, etc.]" are to be interpreted openly as referring to at least one instance of said element, device, component, means, step, etc., unless explicitly stated otherwise. The steps of any method disclosed herein do not have to be performed in the exact order disclosed, unless explicitly stated.

25 As used herein, the term "comprising" and variations of that term are not intended to exclude other additives, components, integers or steps.

Brief description of the drawings

The above, as well as additional objects, features and advantages of
30 the present disclosure, will be better understood through the following illustrative and non-limiting detailed description of preferred embodiments of the present invention, with reference to the appended drawings, where the same reference numerals will be used for similar elements, wherein:

Fig. 1 is a perspective view of a handling apparatus according to one exemplary embodiment of the present invention, and

Figs. 2a-2i are sequence views which illustrate the dismounting of a roller from a roller crusher by means of the handling apparatus.

5

Detailed description of preferred embodiments of the invention

Fig. 1 illustrates a handling apparatus 1 for handling a roller 2 of a roller crusher 3 according to one exemplary embodiment of the present invention. The handling apparatus 1 comprises a movable base 4, a carrier 5, two carrier pivoting devices 6 and two roller pivoting devices 7. The carrier 5 is pivotably attached to the base 4 and adapted to carry a roller 2. The carrier 5 comprises a support member 8 which is adapted to rest against said base 4 for support. The support member 8 thereby increases the stability of the handling device 1 when it carries a roller 2. The carrier 5 has a triangular shape which conforms to an outer shape of a chosen part of the roller crusher 3, in this case a bearing housing 9. The carrier 5 will thus be adapted to receive a bearing housing 9 having a triangular shape. Each one of the two carrier pivoting devices 6 is pivotably attached to the base 4 and to the carrier 5, respectively. The carrier pivoting devices 6 are extendable in their longitudinal direction. Each one of the roller pivoting devices 7 are connected to the base 4 by being pivotably attached to the carrier 5. As an option, the roller pivoting devices 7 can be pivotably attached directly to the base 4. The roller pivoting devices 7 are extendable in their longitudinal direction and adapted to releasably engage said roller 2 via a bearing housing 9 holding the roller 2.

In Fig. 2a, the handling apparatus 1 is illustrated when being transported to the roller crusher 3 for dismounting of the roller 2 of the roller crusher 3.

Fig. 2b illustrates the handling apparatus 1 when being lined up to bearing housing 9 holding the roller 2 to be dismounted.

In Fig. 2c, the carrier 5 of the handling apparatus 1 is pivoted towards the bearing housing 9 holding the roller 2 to be dismounted by means of the

two carrier pivoting devices 6. The carrier pivoting devices 6 are pivoted in relation to the base 4 and extended in their longitudinal direction.

Fig. 2d illustrates how the two roller pivoting devices 7 engage with the bearing housing 9 holding the roller 2 to be dismantled by being pivoted in relation to the carrier 5.

In Fig. 2e, the bearing housing 9 holding the roller 2 to be dismantled is detached from a second attachment point 10 on each side of the roller crusher 3. Additionally, the bearing housing 9 is detached from a fixation point 11 on each side of the roller crusher 3.

Fig. 2f illustrates how the bearing housing 9 holding the roller 2 to be dismantled is pivoted a second angle away from the roller crusher 3. The bearing housing 9 is pivoted by means of the roller pivoting devices 7 which are retracted in their longitudinal direction and pivoted in relation to the carrier 5.

In Fig. 2g, the bearing housing 9 holding the roller 2 to be dismantled is detached from a first attachment point 12 on each side of the roller crusher 3.

Fig. 2h illustrates how the bearing housing 9 holding the roller 2 to be dismantled is pivoted a first angle away from the roller crusher 3. The bearing housing 9 is pivoted by means of the carrier pivoting device 6 which are retracted in their longitudinal direction and pivoted in relation to the base 4. The bearing housing 9 is thus arranged in the handling apparatus 1 and can together with the roller 2 be transported away from the roller crusher 3 as illustrated in Fig. 2i.

According to a second aspect of the invention, a method for mounting a roller to a roller crusher is provided. The method comprises transporting a base having a carrier carrying the roller to the roller crusher, pivoting the carrier a first angle towards the roller crusher, pivotably attaching the roller to a first attachment point of the roller crusher, pivoting the roller a second angle towards the roller crusher, and attaching the roller to a second attachment point of the roller crusher.

According to a third aspect of the invention, a method for dismantling a roller to a roller crusher is provided. The method comprises detaching the

roller from a second attachment point of the roller crusher, pivoting the roller a second angle away from the roller crusher, detaching the roller from a first attachment point of the roller crusher, pivoting a carrier carrying the roller a first angle away from the roller crusher onto a base, transporting the base
5 away from the roller crusher.

The handling apparatus 1 can, for example, run on a fixed track, such as a rail, for transport to and from the roller crusher 3. According to a preferred embodiment of the invention, two handling apparatuses 1 are associated with each roller crusher 3, one on each side of the same. This
10 way, one handling apparatus 1 will be available for each one of the rollers 2.

The invention has mainly been described above with reference to a few embodiments. However, as is readily appreciated by a person skilled in the art, other embodiments than the ones disclosed above are equally possible within the scope of the invention, as defined by below.

15 The size, shape and number of the carrier pivoting device and roller pivoting device of the handling apparatus can naturally be varied to any suitable extent. The handling device can be used both for mounting a roller to a roller crusher and dismounting a roller to a roller crusher, either directly or together with, for example, a bearing housing holding the roller.

20 The carrier can comprise mechanical locking devices in order to fix the bearing housing to the handling apparatus for increased safety during transportation. Also, the carrier can comprise one or several positioning devices in order to facilitate the mounting of a roller to the roller crusher.

The base can comprise a locking device in order to fix the handling
25 apparatus to the ground during the mounting and dismounting operation.

CLAIMS

1. A handling apparatus for handling a roller of a roller crusher, comprising:
- 5 a movable base;
a carrier pivotably attached to said base and adapted to carry the roller;
at least one carrier pivoting device pivotably attached to said base and attached to said carrier, said carrier pivoting device being extendable; and
- 10 at least one roller pivoting device pivotably connected to said base, said roller pivoting device being adapted to releasably engage said roller.
2. A handling apparatus according to claim 1, wherein said roller pivoting device is extendable.
- 15 3. A handling apparatus according to claim 1, wherein said carrier comprises a support member adapted to rest against said base for support.
4. A handling apparatus according to claim 1, wherein said carrier
- 20 has a shape conforming to an outer shape of a bearing housing.
5. A handling apparatus according to claim 4, wherein said shape is a triangular shape.
- 25 6. A handling apparatus according to claim 1, wherein said carrier has power drive in order to rotate over its pivot point.

7. A handling apparatus according to claim 1, wherein said carrier is adjustable to be able to accept different types of rollers or bearing housings.

5 8. A handling apparatus according to claim 1, wherein said base is adapted to be lifted by a lifting machine.

9. A handling apparatus according to claim 1, wherein said base has power drive in order to move along a ground.

10

10. A handling apparatus according to claim 1, wherein said carrier pivoting device is pivotably attached to said carrier.

11. A handling apparatus according to claim 1, wherein said roller pivoting device is pivotably attached to said carrier.

15

12. A handling apparatus according to claim 1, wherein said roller pivoting device is adapted to releasably engage a bearing housing of said roller.

20

13. A method for mounting a roller to a roller crusher, comprising: transporting a base having a carrier carrying the roller to said roller crusher;

pivoting said carrier a first angle towards said roller crusher;

25 pivotably attaching said roller to a first attachment point of said roller crusher;

pivoting said roller a second angle towards said roller crusher; and

attaching said roller to a second attachment point of said roller crusher.

30

14. A method for dismounting a roller to a roller crusher, comprising:
detaching said roller from a second attachment point of said roller
crusher;
pivoting said roller a second angle away from said roller crusher;
5 detaching said roller from a first attachment point of said roller crusher;
pivoting a carrier carrying the roller a first angle away from said roller
crusher onto a base; and
transporting said base away from said roller crusher.

1/6

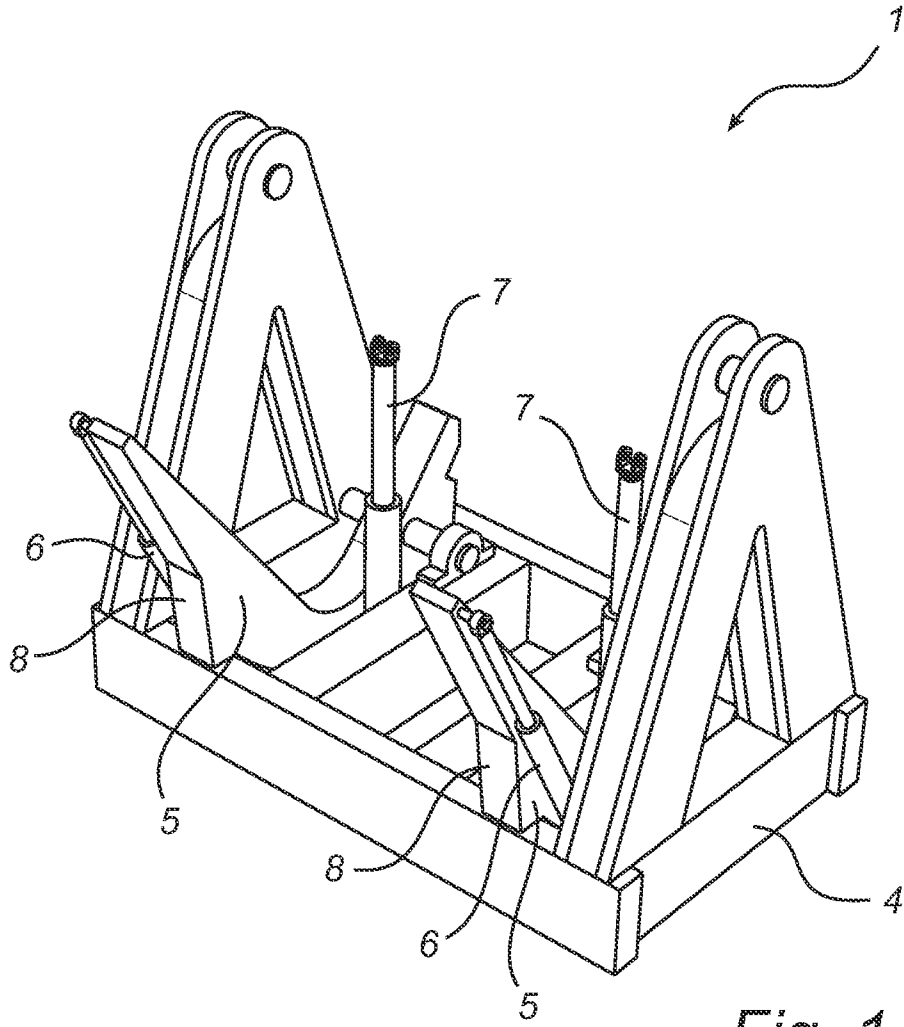

Fig. 1

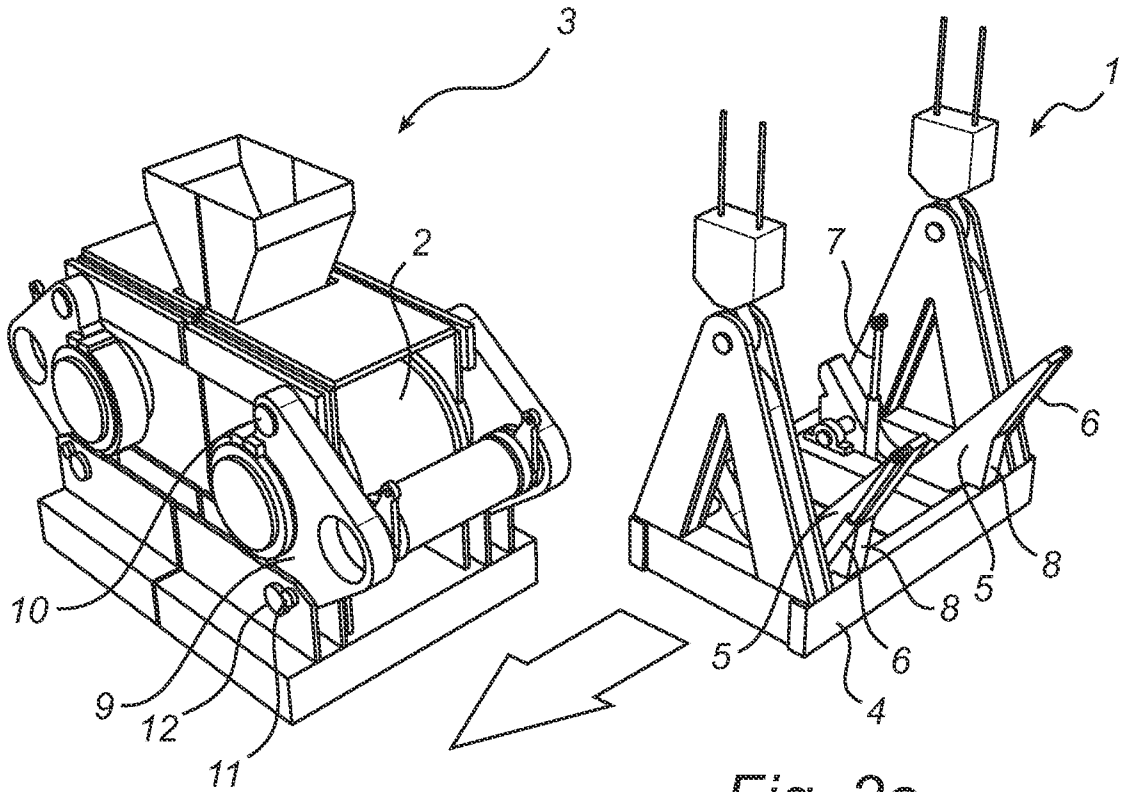

Fig. 2a

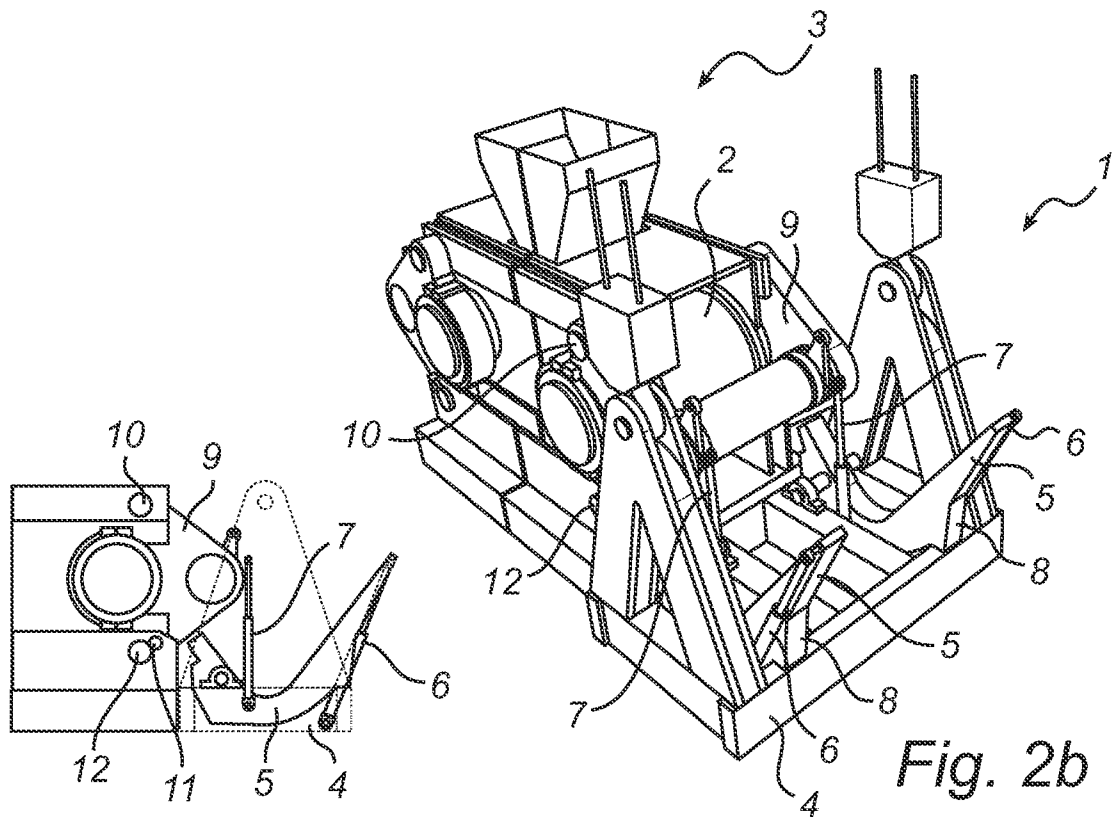

Fig. 2b

3/6

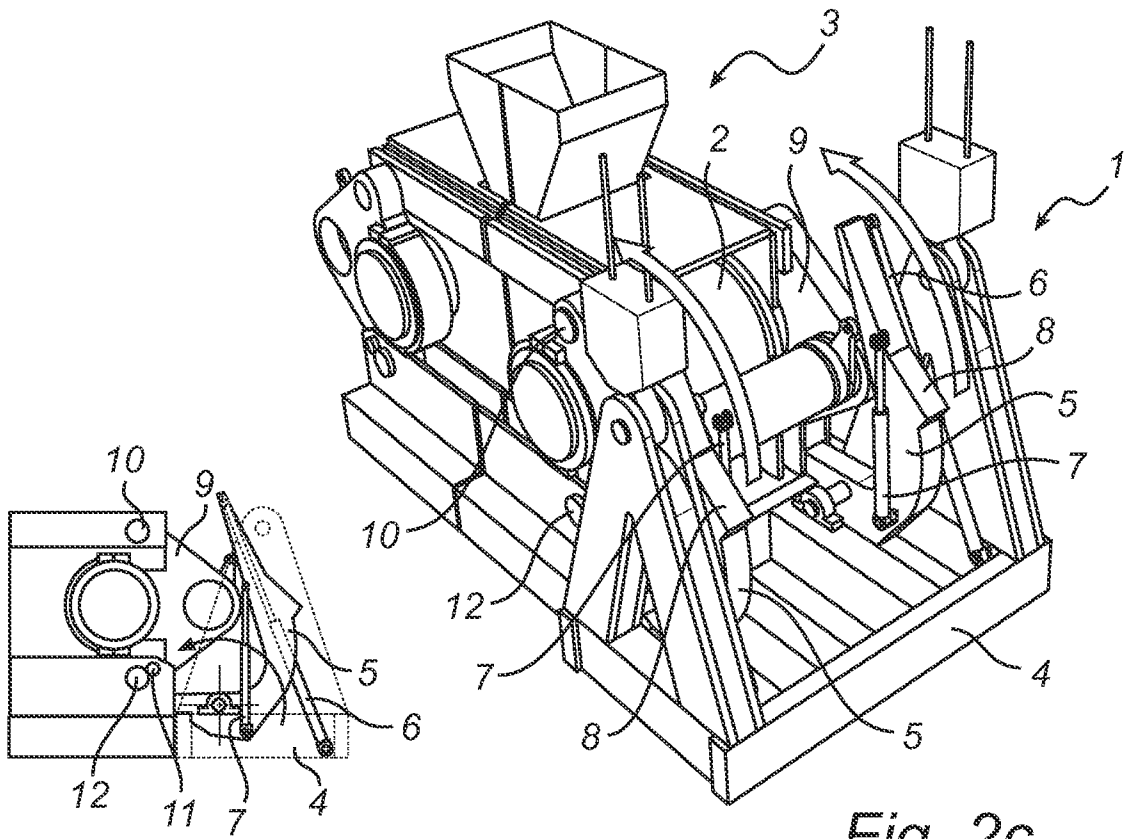

Fig. 2c

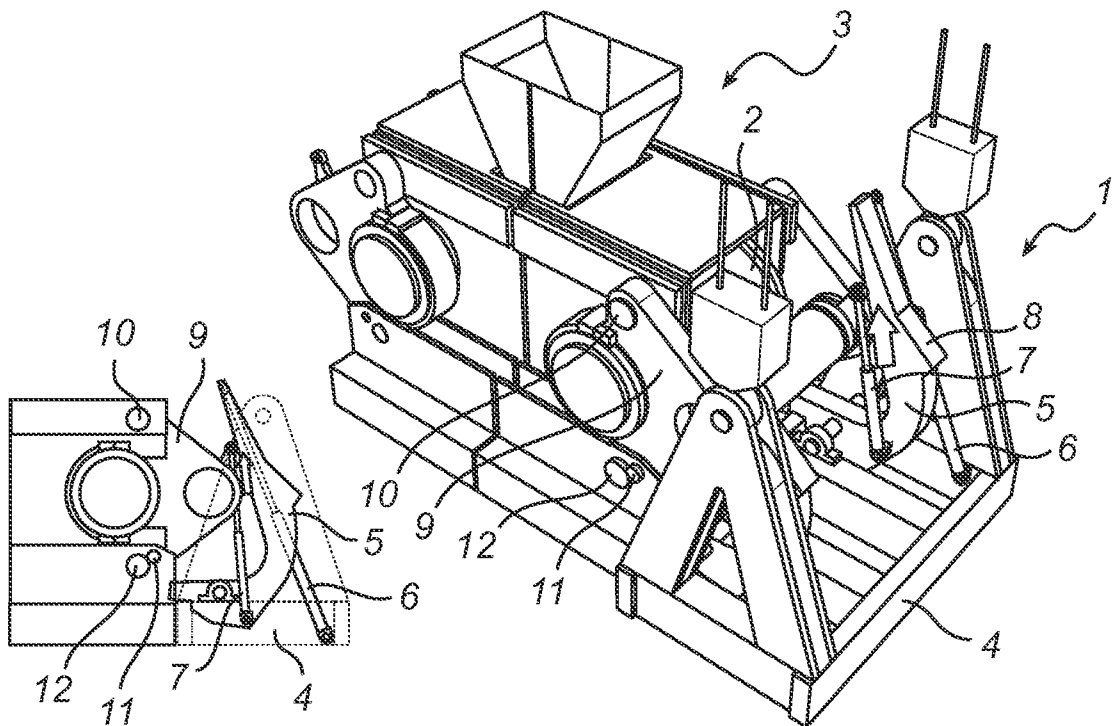
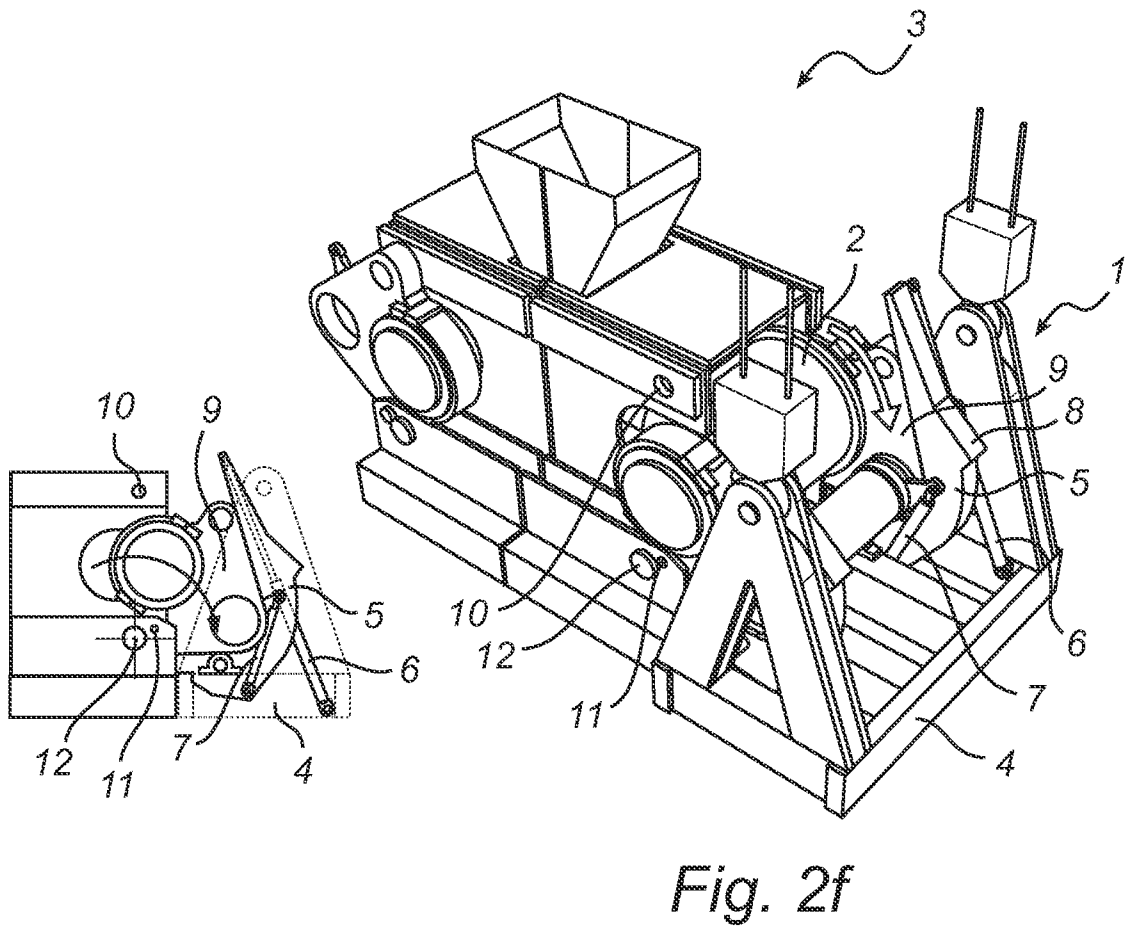
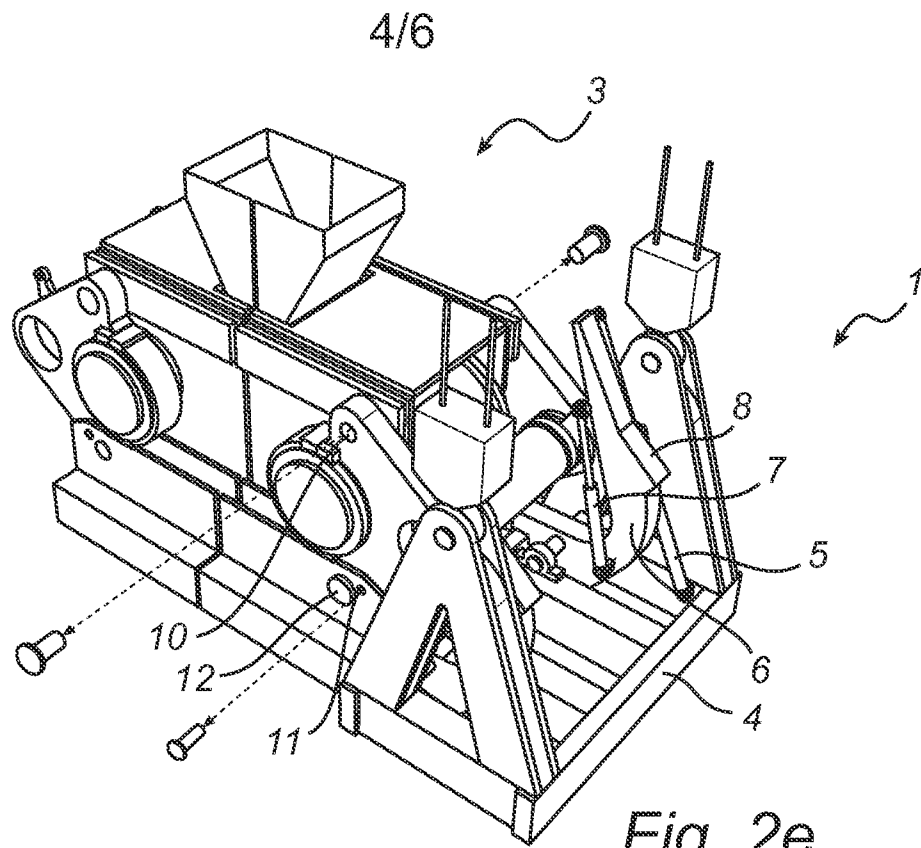

Fig. 2d



5/6

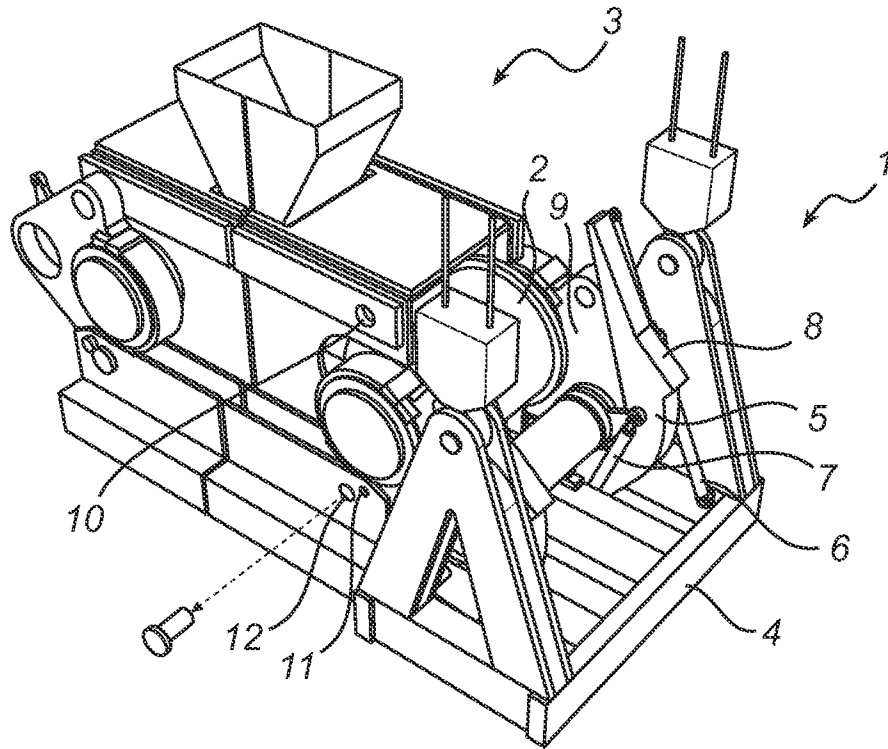

Fig. 2g

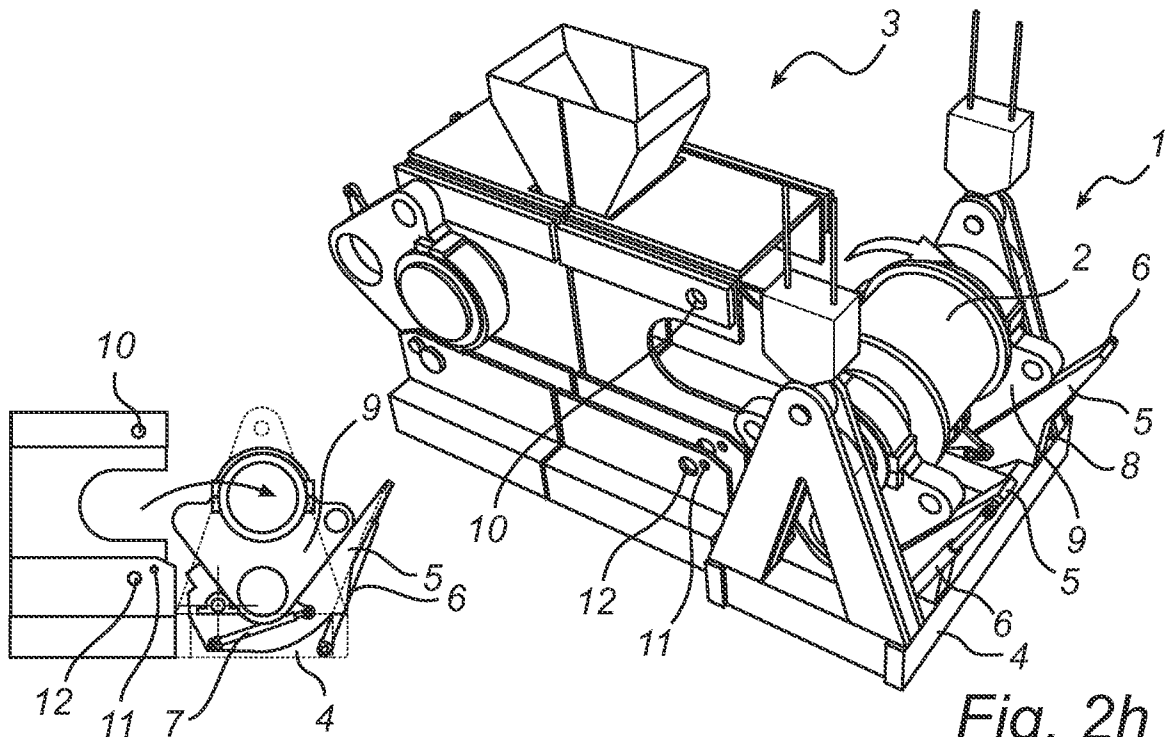

Fig. 2h

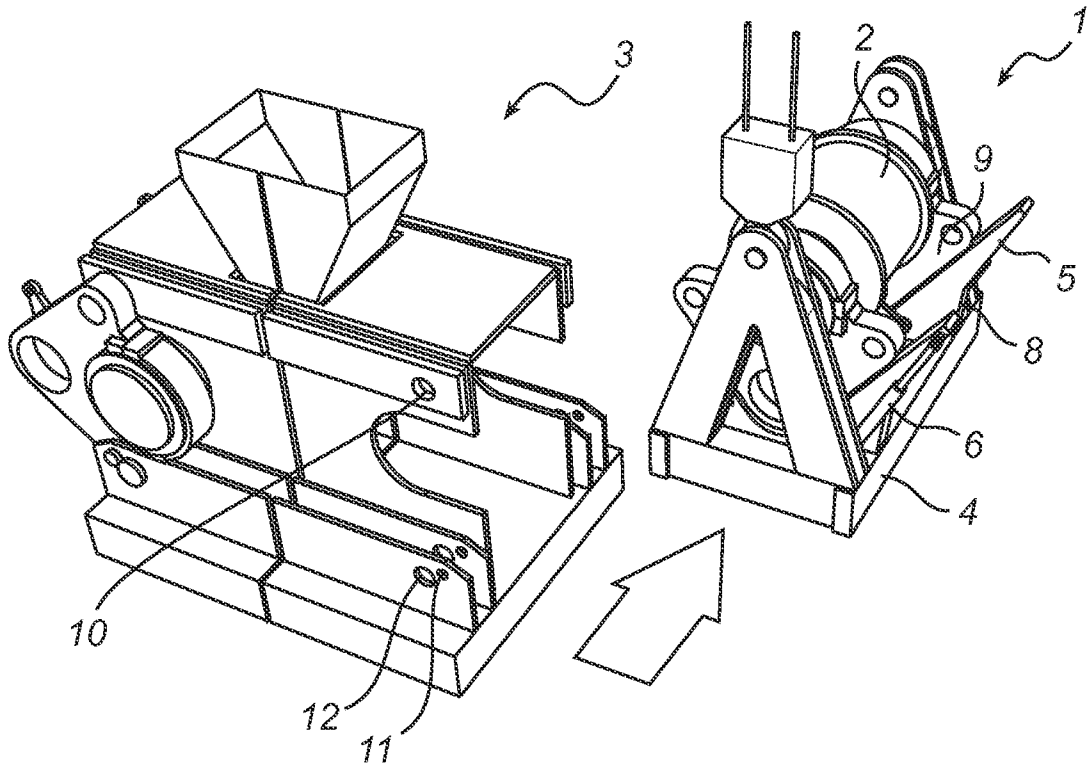

Fig. 2i

INTERNATIONAL SEARCH REPORT

International application No.
PCT/US2013/034068

A. CLASSIFICATION OF SUBJECT MATTER
 IPC(8) - B02C 4/32 (2013.01)
 USPC - 241/232
 According to International Patent Classification (IPC) or to both national classification and IPC

B. FIELDS SEARCHED
 Minimum documentation searched (classification system followed by classification symbols)
 IPC(8) - B02C 4/00, 4/02, 4/08, 4/28, 4/32, 4/42, 15/00, 15/02, 15/04, 18/06, 18/14, 18/16, 19/18, 21/02, 23/08; B21B 13/00, 31/00, 31/10 (2013.01)
 USPC - 29/426.3, 895.23, 895.31; 72/239, 252.5; 212/180; 241/46.15, 159, 178, 179, 183, 203, 227, 232, 235, 285.2

Documentation searched other than minimum documentation to the extent that such documents are included in the fields searched
 CPC - B02C 4/08, 4/28, 4/34, 18/14; B21B 13/001, 31/10, 31/103 (2013.01)

Electronic data base consulted during the international search (name of data base and, where practicable, search terms used)
 PatBase, Google Patent, Google

C. DOCUMENTS CONSIDERED TO BE RELEVANT

Category*	Citation of document, with indication, where appropriate, of the relevant passages	Relevant to claim No.
Y	US 5,580,009 A (KENNEDY) 03 December 1996 (03.12.1996) entire document	1-12
Y	US 3,970,256 A (RUEGGER et al) 20 July 1976 (20.07.1976) entire document	1-7, 10-14
Y	US 5,323,976 A (JOHNSON et al) 28 June 1994 (28.06.1994) entire document	8
Y	US 8,096,745 B2 (LAMOTHE) 17 January 2012 (17.01.2012) entire document	9,13-14
A	US 5,911,373 A (REID) 15 June 1999 (15.06.1999) entire document	1-14
A	US 2011/0097026 A1 (NIKLEWSKI et al) 28 April 2011 (28.04.2011) entire document	1-14
A	US 3,208,678 A (PICK et al) 28 September 1965 (28.09.1965) entire document	1-14

Further documents are listed in the continuation of Box C.

* Special categories of cited documents:

"A" document defining the general state of the art which is not considered to be of particular relevance	"T" later document published after the international filing date or priority date and not in conflict with the application but cited to understand the principle or theory underlying the invention
"E" earlier application or patent but published on or after the international filing date	"X" document of particular relevance; the claimed invention cannot be considered novel or cannot be considered to involve an inventive step when the document is taken alone
"L" document which may throw doubts on priority claim(s) or which is cited to establish the publication date of another citation or other special reason (as specified)	"Y" document of particular relevance; the claimed invention cannot be considered to involve an inventive step when the document is combined with one or more other such documents, such combination being obvious to a person skilled in the art
"O" document referring to an oral disclosure, use, exhibition or other means	"&" document member of the same patent family
"P" document published prior to the international filing date but later than the priority date claimed	

Date of the actual completion of the international search 03 June 2013	Date of mailing of the international search report 19 JUN 2013
---	--

Name and mailing address of the ISA/US Mail Stop PCT, Attn: ISA/US, Commissioner for Patents P.O. Box 1450, Alexandria, Virginia 22313-1450 Facsimile No. 571-273-3201	Authorized officer: Blaine R. Copenheaver PCT Helpdesk: 571-272-4300 PCT OSP: 571-272-7774
---	---