



HU000031562T2

(19) **HU**(11) Lajstromszám: **E 031 562**(13) **T2****MAGYARORSZÁG**
Szellemi Tulajdon Nemzeti Hivatala**EURÓPAI SZABADALOM**
SZÖVEGÉNEK FORDÍTÁSA(21) Magyar ügyszám: **E 15 160427**(51) Int. Cl.: **G06F 13/40** (2006.01)(22) A bejelentés napja: **2015. 03. 24.****G05F 3/02** (2006.01)

(96) Az európai bejelentés bejelentési száma:

EP 20150160427

(97) Az európai bejelentés közzétételi adatai:

EP 2940592 A1 **2015. 11. 04.**

(97) Az európai szabadalom megadásának meghirdetési adatai:

EP 2940592 B1 **2017. 01. 25.**

(30) Elsőbbségi adatok:

201414222852 **2014. 03. 24.** **US**

(73) Jogosult(ak):

Nokia Technologies OY, 02610 Espoo (FI)

(72) Feltaláló(k):

Leinonen, Pekka, 20900 Turku (FI)
Inha, Kai, 04420 Järvenpää (FI)
Talmola, Pekka, 20240 Turku (FI)
Toivola, Timo, 20540 Turku (FI)
Helenius, Teemu, 21870 Riihimäki (FI)
Järvensivu, Seppo, 24800 Hanko (FI)
Vaajala, Kristian, 21420 Lieto (FI)
Hellberg, Tino, 20660 Littoinen (FI)

(74) Képviselő:

Danubia Szabadalmi és Jogi Iroda Kft.,
Budapest

(54)

Lehúzó áramkör egy berendezéshez

Az európai szabadalom ellen, megadásának az Európai Szabadalmi Közlönyben való meghirdetésétől számított kilenc hónapon belül, felszólalást lehet benyújtani az Európai Szabadalmi Hivatalnál. (Európai Szabadalmi Egyezmény 99. cikk(1))

A fordítást a szabadalmat az 1995. évi XXXIII. törvény 84/H. §-a szerint nyújtotta be. A fordítás tartalmi helyességét a Szellemi Tulajdon Nemzeti Hivatala nem vizsgálta.

(19)



(11)

EP 2 940 592 B1

(12)

EUROPEAN PATENT SPECIFICATION

(45) Date of publication and mention of the grant of the patent:
25.01.2017 Bulletin 2017/04

(51) Int Cl.:
G06F 13/40^(2006.01) G05F 3/02^(2006.01)

(21) Application number: **15160427.9**

(22) Date of filing: **24.03.2015**

(54) PULL-DOWN CIRCUITRY FOR AN APPARATUS

PULLDOWN-SCHALTUNG FÜR EINE VORRICHTUNG

CIRCUIT D'EXCURSION BASSE POUR UN APPAREIL

(84) Designated Contracting States:
AL AT BE BG CH CY CZ DE DK EE ES FI FR GB GR HR HU IE IS IT LI LT LU LV MC MK MT NL NO PL PT RO RS SE SI SK SM TR

(30) Priority: **24.03.2014 US 201414222852**

(43) Date of publication of application:
04.11.2015 Bulletin 2015/45

(73) Proprietor: **Nokia Technologies OY**
02610 Espoo (FI)

(72) Inventors:
 • **Leinonen, Pekka**
20900 Turku (FI)
 • **Inha, Kai**
04420 Järvenpää (FI)
 • **Talmola, Pekka**
20240 Turku (FI)

- **Toivola, Timo**
20540 Turku (FI)
- **Helenius, Teemu**
21870 Riihimäki (FI)
- **Järvensivu, Seppo**
24800 Hanko (FI)
- **Vaajala, Kristian**
21420 Lieto (FI)
- **Hellberg, Tino**
20660 Littoinen (FI)

(74) Representative: **Berggren Oy**
P.O. Box 16
Eteläinen Rautatiekatu 10A
00101 Helsinki (FI)

(56) References cited:
WO-A1-2008/146073 US-A1- 2008 247 104
US-A1- 2012 297 207

EP 2 940 592 B1

Note: Within nine months of the publication of the mention of the grant of the European patent in the European Patent Bulletin, any person may give notice to the European Patent Office of opposition to that patent, in accordance with the Implementing Regulations. Notice of opposition shall not be deemed to have been filed until the opposition fee has been paid. (Art. 99(1) European Patent Convention).

Description**FIELD**

[0001] The embodiments relate to an apparatus or dual-role port capability to request power via a wired interface.

BACKGROUND:

[0002] Serial and parallel communication interfaces are widely used to establish communication between devices such as desktop computers and printers, stationary terminals and peripheral devices, personal computers, mobile terminals, and headsets. Unlike older connection standards such as RS-232 or Parallel port, universal serial bus (USB) ports and cables supply both data and electric power, enabling power consumer devices needing operating power, to obtain their operating power via the USB cable from a power provider device. The power provider devices may also include mains adapters or car chargers without data communication capabilities.

[0003] In related art, WO 2008/146073 A1 discloses a method comprising connecting an electronic device having a power source with a second electronic device via a wired interface comprising a first data line and a voltage line, turning off power provided to said voltage line, monitoring the voltage level of said first data line, and determining that said second electronic device has been disconnected if a change from high level to low level is detected. A second method is provided comprising connecting an electronic device with a first electronic device via a wired interface comprising a second data line and a voltage line, connecting a second pull-down resistor with said second data line, monitoring said voltage line, disconnecting said second pull-down resistor from said second data line and connecting a second pull-up resistor with said second data line if power provided on said voltage line is turned off, monitoring a voltage level of said second data line, and determining that said first electronic device has been disconnected if a change from low level to high level is detected.

[0004] Further in related art, US 2008/247104 A1 discloses an electrostatic discharge protection circuit. The disclosed electrostatic discharge protection circuit includes a transfer unit that transfers electrostaticity from at least one of a plurality of input/output pads to a boost bus line, a trigger unit that responds to the electrostaticity transferred via the boost bus line to detect a trigger voltage and apply it to a trigger bus line, and a plurality of clamp units that are connected between the input/output pads and an internal circuit. The clamp units are triggered by the trigger voltage of the trigger unit to discharge electrostaticity of the input/output pads to a first or second power supply voltage line, thereby safely protecting the internal circuit from electrostatic damage and lowering the operating voltage of the clamp unit with minimum costs without increasing an area of the electrostatic dis-

charge protective circuit within a semiconductor integrated circuit.

SUMMARY

[0005] Apparatus embodiments of the invention are disclosed for requesting power via a wired interface.

[0006] According to an example embodiment of the invention, an apparatus comprises:

a pull-down circuit in the apparatus acting as a power consumer when there is no energy in the apparatus, the pull-down circuit being connected via a configuration line over a cable to a power provider device, the pull-down circuit being configured to use energy from the configuration line to pull down a voltage on the configuration line, to signal the power provider device to provide power over another line of the cable to the apparatus.

[0007] According to an example embodiment of the invention, an apparatus comprises:

wherein the apparatus is a device with a Dual-Role Port, the pull-down circuit is connected via a Configuration Channel line over a USB-Type C cable to the power provider device, and the other line of the cable is a VBUS line of the USB-Type C cable to the power provider device.

[0008] According to an example embodiment of the invention, an apparatus comprises:

wherein the pull-down circuit comprises at least one of an FET circuit, a transistor circuit, a diode circuit, a relay switch, or a MEMS switch that provides the pull-down

[0009] According to an example embodiment of the invention, an apparatus comprises:

wherein the pull-down circuit further comprises an N-channel FET, having its gate coupled through a resistor to the configuration channel line of the cable, its source connected to ground potential, and its drain connected to the configuration channel line of the cable, the N-channel FET being configured to become more conductive, reducing voltage on the configuration channel line of the cable, thereby signaling the power provider device over the configuration channel line, to provide power to the apparatus on the VBUS line of the cable.

[0010] According to an example embodiment of the invention, an apparatus comprises:

wherein the pull-down circuit further comprises a p-channel FET, having its gate coupled through a re-

sistor to ground potential, its drain connected to ground potential, and its source connected to the configuration channel line of the cable, the p-channel FET being configured to conduct through its source-drain path, thereby reducing voltage on the configuration channel line of the cable, thereby signaling the power provider device over the configuration channel line, to provide power to the apparatus on the VBUS line of the cable.

[0011] According to an example embodiment of the invention, an apparatus comprises:

wherein the pull-down circuit further comprises a diode, with its cathode coupled through a resistor to ground potential and its anode connected to the configuration channel line of the cable, the diode being configured to conduct, thereby reducing voltage on the configuration channel line of the cable, thereby signaling the power provider device over the configuration channel line, to provide power to the apparatus on the VBUS line of the cable.

[0012] According to an example embodiment of the invention, an apparatus comprises:

wherein the apparatus is a device with a Device-Role Port, the pull-down circuit is connected via a Configuration Channel line over a USB-Type C cable to the power provider device, and the other line of the cable is a VBUS line of the USB-Type C cable to the power provider device.

[0013] According to an example embodiment of the invention, an apparatus comprises:

a pull-down circuit in the apparatus with a Dual-Role Port acting as power consumer when there is no energy in the apparatus, the pull-down circuit being connected via a Configuration Channel line over a USB-Type C cable to a power provider device, the pull-down circuit being configured to use energy from the Configuration Channel line to pull down a voltage on the Configuration Channel line, to signal the power provider device to provide power over a VBUS line of the USB-Type C cable to the apparatus.

[0014] According to an example embodiment of the invention, an apparatus comprises:

wherein the apparatus includes a battery that becomes charged by the power provided on the VBUS line and, in response, the pull down circuit stops pulling down the voltage of the Configuration Channel line and releases control of the Configuration Channel to other circuitry having a capability for logic decisions.

[0015] According to an example embodiment of the invention, an apparatus comprises:

wherein the apparatus is acting as a power consumer when in a power down mode.

[0016] According to an example embodiment of the invention, an apparatus comprises:

wherein the apparatus is acting as a power consumer when it has an empty battery.

[0017] According to an example embodiment of the invention, an apparatus comprises:

wherein the apparatus is acting as a power consumer when it has no battery.

[0018] In this manner, embodiments of the invention enable requesting power via a wired interface.

DESCRIPTION OF THE FIGURES

[0019]

Figure 1A illustrates an example functional block diagram of a power provider device and a Device with Dual-Role port acting as Power Consumer to be connected by a USB cable.

Figure 1B illustrates an example layout of the USB Type-C connector pinning.

Figure 2 illustrates an example circuit diagram of an N-channel FET pull-down circuit in the Device with Dual-Role port acting as Power Consumer, in accordance with an example embodiment of the invention.

Figure 2A illustrates an example circuit diagram of an N-channel FET pull-down circuit in the Device with Device-Role port acting as Power Consumer, in accordance with an example embodiment of the invention.

Figure 3 illustrates an example circuit diagram of a P-channel FET pull-down circuit in the Device with Dual-Role port acting as Power Consumer, in accordance with an example embodiment of the invention.

Figure 4 illustrates an example circuit diagram of a diode pull-down circuit in the Device with Dual-Role port acting as Power Consumer, in accordance with an example embodiment of the invention.

DISCUSSION OF EXAMPLE EMBODIMENTS

[0020] A USB system may include a host, a plurality of downstream USB ports, and a plurality of peripheral devices connected in a tiered-star topology. Additional USB hubs may be included in the tiers, allowing branching into a tree structure with up to five tier levels. A USB

host may have multiple host controllers and each host controller may provide one or more USB ports. Up to 127 devices, including hub devices, may be connected to a single host controller.

[0021] A new USB Type-C connector is an interface supporting the USB 3.0 level of communication. The USB Type-C connector features a Dual-Role Port that can operate as either a Downstream Facing Port (DFP) or an Upstream Facing Port (UFP). A Downstream Facing Port typically the ports on a host or the ports on a hub to which devices are connected. An Upstream Facing Port is a port on a device or a hub that connects to a host or the Downstream Facing Port of a hub. The role that the port offers may be fixed to either a Downstream Facing Port (DFP) or an Upstream Facing Port (UFP) or may alternate between the two port states. The port's role may be changed dynamically. The USB Type-C connector is symmetrical so that it may be plugged in both ways, up-side-up or up-side-down. The polarity of the plug and power provider/power consumer role will be configured by a system called Configuration Channel (CC), which has two pins CC1 and CC2 at each receptacle, but only one of them, CC1, is wired through the cable from the plugs. Using this feature the power provider and power consumer devices may figure out which role they are to play in the connection setup.

[0022] Both Configuration Channel (CC)-pins are pulled up in the power provider side and pulled down in the power consumer side by resistors. When the cable is connected between the power provider and power consumer, both may monitor both of the Configuration Channel (CC)-pins and see that at both ends only one pin will change its voltage level. Noting which pin this is, the power provider or device may negotiate which way the plug is inserted locally. After the valid connection is detected, a +5 V VCONN voltage or voltage supply is applied to the unused CC-pin for possible active cables.

[0023] In the USB Type-C Dual-Role Port connector, a single connector line (VBUS) may be used as either the power source or the power sink. The power provider and power consumer devices must negotiate this the direction of power at the time of setup. For this negotiation, the device that is to consume power, pulls the voltage of the Configuration Channel (CC) connector line low at the time when galvanic connection between connector contacts is established. This lowering of the voltage in the Configuration Channel (CC) line is detected by the power provider device, thereby establishing their respective roles.

[0024] A Dual-Role Port device without power or with a dead battery, needs to act as a power consumer device at setup time, to be able to get charging power from a power provider device or host via the VBUS. To act as a power consumer device, the Dual-Role Port needs to pull the Configuration Channel (CC) line below 1.8V and above 0.4V. A semiconductor switch in the Dual-Role Port device acting as a power consumer, would not be able to connect the Configuration Channel (CC) line to a

low voltage level, without having proper operating voltage.

[0025] Figure 1A illustrates an example functional block diagram of a power provider device 102 and a Device with Dual-Role port acting as Power Consumer 104 to be connected by a cable 130, such as for example a USB cable. The connector 140, such as a USB Type-C connector, has an example USB Type-C connector pinning shown in Figure 1B. The power provider device 102 has a receptacle 120, such as for example a USB type-C receptacle to receive the connector 140 plugged into the receptacle 120. The figure shows the pull-down circuit 300 in the Device with Dual-Role port acting as Power Consumer 104, in accordance with an example embodiment of the invention.

[0026] The power provider device 102 may include processing logic 222 that may include one or several central processor units (CPUs) 224 and 225, a random-access memory (RAM) 226, and a read-only memory (ROM) 227. Alternately, processing logic 222 may include programmed logic arrays of sequential and combinatorial logic circuits and state machine logic implementing some or all of the steps performed by embodiments of the invention. The source protocol 112 may be embodied as a programmed sequence of executable instructions stored in the RAM or ROM and executed by the central processor unit (CPU) to carry out the functions of embodiments of the invention.

[0027] Power Consumer 104 is an apparatus acting as a power consumer when there is no energy in the apparatus. This means that it may be in a power down mode, or that it may have an empty battery, or that it may have no battery.

[0028] Figure 2 illustrates an example circuit diagram of a pull-down circuit 300 in the Device with Dual-Role port acting as Power Consumer 104, in accordance with an example embodiment of the invention. When there is a dead battery, or no power source, inside a device 104 having a Dual-Role port, its Configuration Channel (CC) line must be pulled down in order to get power from a power provider or host 102, in a USB Type - C arrangement. In the USB Type - C arrangement, the power provider or host 104 will not provide any voltage on the VBUS line, before the Configuration Channel (CC) line is pulled down. The Device with Dual-Role port acting as Power Consumer 104 needs to make its Configuration Channel (CC) line to go down, without its having any of its own power available.

[0029] In accordance with an example embodiment of the invention, the pull-down circuit 300 in the Device with Dual-Role port acting as Power Consumer 104, uses a bit of energy from the Configuration Channel (CC) line, itself, to pull down the voltage of the Configuration Channel (CC) line, making it go down enough to trigger the power provider or host 104 to start charging the VBUS line. If the Power Consumer device 104 includes a battery that becomes charged by the power provided on the VBUS line, then in response, the pull down circuit 300

stops pulling down the voltage of the Configuration Channel line and releases control of the Configuration Channel to other circuitry having a capability for logic decisions, such as a CPU.

[0030] The pull-down circuit 300 in the Device with Dual-Role port acting as Power Consumer 104, may be an FET circuit, transistor, relay, MEMS switch, or another type of circuit that is capable of providing the pull-down, if that device has a dead battery or no power source of its own. Example embodiments of the invention may be more generally applied to power interfaces where the power consumer requests power by pulling a line low, where the device has its own power off or when its battery is empty.

[0031] An example n-channel FET pull-down circuit 300 is shown in Figure 2. In an example embodiment of the invention, the N-channel FET2 has its gate coupled through a resistor R2 to the Configuration Channel (CC) line of the USB-Type C cable, its source connected to ground potential, and its drain connected to the Configuration Channel (CC) line of the cable. The N-channel FET2 is configured to become more conductive, reducing voltage on the Configuration Channel (CC) line of the cable, thereby signaling the power provider device 102 over the Configuration Channel (CC) line, to provide power to the apparatus on the VBUS line of the cable.

[0032] When dual role port device 104 is in a power off mode or has a dead battery, the device's VCONN voltage or voltage supply is not present at the gate of FET1 and the FET1 will not conduct. When a power provider or host 102 is attached to this dual role port, it will apply a voltage (VCON) through a resistor to the Configuration Channel (CC) line. This VCONN voltage or voltage supply is applied to the gate of FET2 and FET2 starts to conduct. As FET2 starts to conduct, it will draw the Configuration Channel (CC) line voltage down. At the same time the Configuration Channel (CC) line is drawing the FET2 gate voltage too low to keep FET2 conducting. Thus, FET2 starts to "toggle" and will keep its drain to source voltage of FET2 at approximately its threshold voltage (1.2V threshold recommended). This drain to source voltage of 1.2V is then detected on the Configuration Channel (CC) line by the power provider or host device 102, which indicates to the power provider or host device 102 that it should assume the role of providing power to the Device with Dual-Role port acting as Power Consumer 104, by providing charging power through the VBUS line.

[0033] When the power provider or host 102 provides power on the VBUS line to the Device with Dual-Role port acting as Power Consumer 104, the device 104 will either power itself up (if that is its required functionality) or first start to charge its dead battery and power-up (if required) after the level of its battery charge is in a "battery good"-level. When the device 104 succeeds in powering up, it will provide its VCONN voltage or voltage supply to the gate of FET1, and when FET1 becomes conductive, it lowers the voltage on the gate of FET2, thereby turning FET2 off and raising the voltage on the Configu-

ration Channel (CC). The power provider or host device 102 will detect the rise in voltage on the Configuration Channel (CC) line and may reduce or stop providing power on the VBUS line to the device 104. If the device 104 has a limited amount of charge in reserve and later depletes its charge, the pull-down circuit 300, once again, will signal the power provider or host device 102 to resume providing power on the VBUS line.

[0034] Figure 2A illustrates an example circuit diagram of an N-channel FET pull-down circuit in the Device with Device-Role port acting as Power Consumer, in accordance with an example embodiment of the invention. The situation is same with the device-mode port devices as per USB Type-C specification. Those device-mode devices need to support VCONN or voltage supply for the active cables, which leads to situation that devices need to have capability to switch pull down off as well.

[0035] Figure 3 illustrates an example circuit diagram of a P-channel FET pull-down circuit 350 in the dual role port in the Device with Dual-Role port acting as Power Consumer 104, in accordance with an example embodiment of the invention. The p-channel FET1 has its gate coupled through a resistor R1 to ground potential, its drain connected to ground potential, and its source connected to the Configuration Channel (CC) of the USB-Type C cable. The p-channel FET is configured to conduct through its source-drain path, thereby reducing voltage on the Configuration Channel (CC) line of the cable, thereby signaling the power provider device over the Configuration Channel (CC) line, to provide power to the apparatus on the VBUS line of the cable.

[0036] When a dual role port device 104 is in power off mode or with dead battery, its VCONN or voltage supply is not present and P-channel FET1 will conduct, since its gate is grounded. When a power provider or host device 102 is attached to the dual role port device 104, power provider or host device 102 will apply voltage (VCON) through a resistor to the Configuration Channel (CC) line. P-channel FET1 will draw Configuration Channel (CC) line voltage down and will keep its drain to source voltage around the FETs threshold voltage (1.2V threshold recommended). This drain to source voltage of 1.2V is then detected on the Configuration Channel (CC) line by the power provider or host device 102, which indicates to the power provider or host device 102 that it should assume the role of providing power to the device 104, by providing charging power through the VBUS line.

[0037] When the power provider or host 102 provides power on the VBUS line to the Device with Dual-Role port acting as Power Consumer 104, the power consumer device 104 will either power itself up (if that is its required functionality) or first start to charge its dead battery and power-up (if required) after the level of its battery charge is in a "battery good"-level. When the device 104 succeeds in powering up, it will provide its VCONN voltage or voltage supply to the gate of P-channel FET1, and when P-channel FET1 stops conducting, it raises the voltage on the Configuration Channel (CC). The power pro-

vider or host device 102 will detect the rise in voltage on the Configuration Channel (CC) line and may reduce or stop providing power on the VBUS line to the device 104. If the device 104 has a limited amount of charge in reserve and later depletes its charge, the pull-down circuit 350, once again, will signal the power provider or host device 102 to resume providing power on the VBUS line.

[0038] Figure 4 illustrates an example circuit diagram of a diode pull-down circuit in the dual role port in the power consumer device, in accordance with an example embodiment of the invention. The diode D1 which is connected to the output terminal VCONN regulator as the pull-down device. The output terminal may be connected through a resistance, to ground potential. The Configuration Channel (CC) line is pulled low via the diode D1. The diode is configured to conduct, thereby reducing voltage on the Configuration Channel (CC) line of the USB-Type C cable, thereby signaling the power provider device over the Configuration Channel (CC) line, to provide power to the apparatus on the VBUS line of the cable.

[0039] Using the description provided herein, the embodiments may be implemented as a machine, process, or article of manufacture by using standard programming and/or engineering techniques to produce programming software, firmware, hardware or any combination thereof.

[0040] Some or all of the steps disclosed herein may be embodied as hardware program logic included in programmed logic arrays of sequential and/or combinatorial logic circuits and/or state machine logic implementing some or all of the steps performed by embodiments of the invention.

[0041] Any resulting program(s), having computer-readable program code, may be embodied on one or more computer-usable non-transitory media such as resident memory devices, smart cards or other removable memory devices, or transmitting devices, thereby making a computer program product or article of manufacture according to the embodiments.

[0042] As indicated above, memory/storage devices include, but are not limited to, disks, optical disks, removable memory devices such as smart cards, SIMs, WIMs, semiconductor memories such as RAM, ROM, PROMS, etc. Transmitting mediums include, but are not limited to, transmissions via wireless communication networks, the Internet, intranets, telephone/modem-based network communication, hard-wired/cabled communication network, satellite communication, and other stationary or mobile network systems/communication links.

[0043] Although specific example embodiments have been disclosed, a person skilled in the art will understand that changes can be made to the specific example embodiments without departing from the scope of the invention as claimed.

Claims

1. An apparatus (104), comprising:

5 a pull-down circuit (300, 350, D1) in the apparatus (104) acting as a power consumer when there is no energy in the apparatus (104), the pull-down circuit (300, 350, D1) being connectable via a configuration line (CC) over a cable (130) to a power provider device (102), the pull-down circuit (300, 350, D1) being configured to use energy from the configuration line (CC) to pull down a voltage on the configuration line (CC), to signal the power provider device (102) to provide power over another line (VBUS) of the cable (130) to the apparatus (104).

2. The apparatus (104) of claim 1, wherein the apparatus (104) is a device with a Dual-Role Port, the pull-down circuit (300, 350) is connected via a Configuration Channel line over a USB-Type C cable to the power provider device (102), and the other line of the cable is a VBUS line of the USB-Type C cable to the power provider device (102).

3. The apparatus (104) of claim 1 or claim 2, wherein the pull-down circuit (300, 350, D1) comprises at least one of an FET circuit, a transistor circuit, a diode circuit, a relay switch, or a MEMS switch that provides the pull-down.

4. The apparatus (104) of any of the preceding claims, wherein the pull-down circuit (300) further comprises:

35 an N-channel FET, having its gate coupled through a resistor (R2) to the configuration channel line (CC) of the cable (130), its source connected to ground potential, and its drain connected to the configuration channel line (CC) of the cable (130), the N-channel FET being configured to become more conductive, reducing voltage on the configuration channel line (CC) of the cable (130), thereby signaling the power provider device (102) over the configuration channel line (CC), to provide power to the apparatus (104) on the VBUS line of the cable (130).

5. The apparatus (104) of any of the preceding claims, wherein the pull-down circuit (350) further comprises:

55 a p-channel FET, having its gate coupled through a resistor (R1) to ground potential, its drain connected to ground potential, and its source connected to the configuration channel line (CC) of the cable (130), the p-channel FET

- being configured to conduct through its source-drain path, thereby reducing voltage on the configuration channel line (CC) of the cable (130), thereby signaling the power provider device (102) over the configuration channel line (CC), to provide power to the apparatus (104) on the VBUS line of the cable (130).
6. The apparatus (104) of any of the preceding claims, wherein the pull-down circuit further comprises:
- a diode (D1), with its cathode coupled through a resistor to ground potential and its anode connected to the configuration channel line (CC) of the cable (130), the diode (D1) being configured to conduct, thereby reducing voltage on the configuration channel line (CC) of the cable (130), thereby signaling the power provider device (102) over the configuration channel line (CC), to provide power to the apparatus (104) on the VBUS line of the cable (130).
7. The apparatus (104) of any of the preceding claims, wherein the apparatus is a device with a Device-Role Port, the pull-down circuit (300, 350, D1) is connected via a Configuration Channel line over a USB-Type C cable to the power provider device (102), and the other line of the cable is a VBUS line of the USB-Type C cable to the power provider device (102).
8. The apparatus (104) of any of the preceding claims, wherein the apparatus (104) is acting as a power consumer when in a power down mode.
9. The apparatus (104) of any of the preceding claims, wherein apparatus (104) is acting as a power consumer when has one of an empty battery and no battery.
10. The apparatus (104) of claim 1, wherein:
- the pull-down circuit (300, 350, D1) in the apparatus (104) has a Dual-Role Port acting as the power consumer when there is no energy in the apparatus;
- the configuration line (CC) is a Configuration Channel line;
- the cable (130) is a USB-Type C cable; and
- the power provider device (102) is signaled to provide power over a VBUS line of the USB-Type C cable to the apparatus (104).
11. The apparatus (104) of claim 10, wherein the apparatus (104) includes a battery that becomes charged by the power provided on the VBUS line and, in response, the pull down circuit (300, 350, D1) stops pulling down the voltage of the Configuration Channel line and releases control of the Configuration Channel to other circuitry having a capability for logic decisions.
12. The apparatus (104) of claim 10 or claim 11, wherein the apparatus (104) is acting as a power consumer when the apparatus (104) is in at least one of in a power down mode, having an empty battery and having no battery.
13. A method, comprising:
- setting a pull-down circuit (300, 350, D1) in an apparatus (104) acting as a power consumer when there is no energy in the apparatus (104), the pull-down circuit (300, 350, D1) being connectable via a configuration line (CC) over a cable (130) to a power provider device (102), for using energy from the configuration line (CC) to pull down a voltage on the configuration line (CC), to signal the power provider device (102) to provide power over another line (VBUS) of the cable (130) to the apparatus (104).
14. The method of claim 13, wherein the pull-down circuit (300, 350, D1) comprises at least one of an FET circuit, a transistor circuit, a diode circuit, a relay switch, or a MEMS switch that provides the pull-down.
15. The method of claim 13 or claim 14, wherein the apparatus (104) is acting as a power consumer when the apparatus (104) is at least one of in a power down mode, having an empty battery and having no battery.

Patentansprüche

1. Vorrichtung (104), die Folgendes umfasst:

eine Pull-down-Schaltung (300, 350, D1), die in der Vorrichtung (104) als ein Leistungsverbraucher fungiert, wenn in der Vorrichtung (104) keine Energie vorhanden ist, wobei die Pull-down-Schaltung (300, 350, D1) über eine Konfigurationsleitung (CC) über ein Kabel (130) mit einer Leistungsversorgungseinrichtung (102) verbunden werden kann, wobei die Pull-down-Schaltung (300, 350, D1) konfiguriert ist, Energie aus der Konfigurationsleitung (CC) zu verwenden, um eine Spannung auf der Konfigurationsleitung (CC) herabzusetzen, um der Leistungsversorgungseinrichtung (102) zu signalisieren, die Vorrichtung (104) über eine andere Leitung (VBUS) des Kabels (130) mit Leistung zu versorgen.

2. Vorrichtung (104) nach Anspruch 1, wobei die Vor-

- richtung (104) einer Einrichtung mit einem Doppelfunktionsanschluss entspricht, wobei die Pull-down-Schaltung (300, 350) über eine Konfigurationskanalleitung über ein USB-Typ C-Kabel mit der Leistungsversorgungseinrichtung (102) verbunden ist, und die andere Leitung des Kabels eine VBUS-Leitung des USB-Typ C-Kabels zu der Leistungsversorgungseinrichtung (102) ist.
3. Vorrichtung (104) nach Anspruch 1 oder Anspruch 2, wobei die Pull-down-Schaltung (300, 350, D1) eine FET-Schaltung, eine Transistorschaltung, eine Diodenschaltung, einen Relaischalter und/oder einen MEMS-Schalter umfasst, der das Herabsetzen bereitstellt.
4. Vorrichtung (104) nach einem der vorhergehenden Ansprüche, wobei die Pull-down-Schaltung (300) ferner Folgendes umfasst:
- einen N-Kanal-FET, dessen Gate durch einen Widerstand (R2) mit der Konfigurationskanalleitung (CC) des Kabels (130) verbunden ist, dessen Source mit dem Massepotential verbunden ist und dessen Drain mit der Konfigurationskanalleitung (CC) des Kabels (130) verbunden ist, wobei der N-Kanal-FET konfiguriert ist, stärker leitend zu werden, wodurch die Spannung auf der Konfigurationskanalleitung (CC) des Kabels (130) reduziert wird, wodurch der Leistungsversorgungseinrichtung (102) über die Konfigurationskanalleitung (CC) signalisiert wird, die Vorrichtung (104) auf der VBUS-Leitung des Kabels (130) mit Leistung zu versorgen.
5. Vorrichtung (104) nach einem der vorhergehenden Ansprüche, wobei die Pull-down-Schaltung (350) ferner Folgendes umfasst:
- einen p-Kanal-FET, dessen Gate durch einen Widerstand (R1) mit dem Massepotential verbunden ist, dessen Drain mit dem Massepotential verbunden ist und dessen Source mit der Konfigurationskanalleitung (CC) des Kabels (130) verbunden ist, wobei der p-Kanal-FET konfiguriert ist, durch seinen Source-Drain-Pfad zu leiten, wodurch die Spannung auf der Konfigurationskanalleitung (CC) des Kabels (130) reduziert wird, wodurch der Leistungsversorgungseinrichtung (102) über die Konfigurationskanalleitung (CC) signalisiert wird, die Vorrichtung (104) auf der VBUS-Leitung des Kabels (130) mit Leistung zu versorgen.
6. Vorrichtung (104) nach einem der vorhergehenden Ansprüche, wobei die Pull-down-Schaltung ferner Folgendes umfasst:
- eine Diode (D1), deren Kathode durch einen Widerstand mit dem Massepotential gekoppelt ist und deren Anode mit der Konfigurationskanalleitung (CC) des Kabels (130) verbunden ist, wobei die Diode (D1) konfiguriert ist, zu leiten, wodurch die Spannung auf der Konfigurationskanalleitung (CC) des Kabels (130) reduziert wird, wodurch der Leistungsversorgungsvorrichtung (102) über die Konfigurationskanalleitung (CC) signalisiert wird, die Vorrichtung (104) auf der VBUS-Leitung des Kabels (130) mit Leistung zu versorgen.
7. Vorrichtung (104) nach einem der vorhergehenden Ansprüche, wobei die Vorrichtung eine Einrichtung mit einem Einrichtungsfunktionsanschluss ist, wobei die Pull-down-Schaltung (300, 350, D1) über eine Konfigurationskanalleitung über ein USB-Typ C-Kabel mit der Leistungsversorgungseinrichtung (102) verbunden ist, und die andere Leitung des Kabels eine VBUS-Leitung des USB-Typ C-Kabels zu der Leistungsversorgungseinrichtung (102) ist.
8. Vorrichtung (104) nach einem der vorhergehenden Ansprüche, wobei die Vorrichtung (104) als ein Leistungsverbraucher fungiert, wenn sie sich in einem Abschaltmodus befindet.
9. Vorrichtung (104) nach einem der vorhergehenden Ansprüche, wobei die Vorrichtung (104) als ein Leistungsverbraucher fungiert, wenn sie eine leere Batterie oder keine Batterie hat.
10. Vorrichtung (104) nach Anspruch 1, wobei:
- die Pull-down-Schaltung (300, 350, D1) in der Vorrichtung (104) einen Doppelfunktionsanschluss aufweist, der als Leistungsverbraucher fungiert, wenn in der Vorrichtung keine Energie vorhanden ist;
- die Konfigurationsleitung (CC) eine Konfigurationskanalleitung ist;
- das Kabel (130) ein USB-Typ C-Kabel ist; und
- der Leistungsversorgungseinrichtung (102) signalisiert wird, die Vorrichtung (104) über eine VBUS-Leitung des USB-Typ C-Kabels mit Leistung zu versorgen.
11. Vorrichtung (104) nach Anspruch 10, wobei die Vorrichtung (104) eine Batterie enthält, die durch die auf der VBUS-Leitung bereitgestellte Leistung geladen wird, und die Pull-down-Schaltung (300, 350, D1) als Reaktion darauf das Herabsetzen der Spannung der Konfigurationskanalleitung beendet und die Steuerung des Konfigurationskanals für andere Schaltungsanordnungen freigibt, die eine Fähigkeit für logische Entscheidungen aufweisen.

12. Vorrichtung (104) nach Anspruch 10 oder Anspruch 11, wobei die Vorrichtung (104) als ein Leistungsverbraucher fungiert, wenn sich die Vorrichtung (104) im Abschaltmodus befindet, eine leere Batterie aufweist und/oder keine Batterie aufweist.

13. Verfahren, das Folgendes umfasst:

Einsetzen einer Pull-down-Schaltung (300, 350, D1) in eine Vorrichtung (104), die als ein Leistungsverbraucher fungiert, wenn keine Energie in der Vorrichtung (104) vorhanden ist, wobei die Pull-down-Schaltung (300, 350, D1) über eine Konfigurationsleitung (CC) über ein Kabel (130) mit einer Leistungsversorgungseinrichtung (102) verbunden werden kann, um Energie aus der Konfigurationsleitung (CC) zu verwenden, um eine Spannung auf der Konfigurationsleitung (CC) herabzusetzen, um der Leistungsversorgungseinrichtung (102) zu signalisieren, die Vorrichtung (104) über eine andere Leitung (VBUS) des Kabels (130) mit Leistung zu versorgen.

14. Verfahren nach Anspruch 13, wobei die Pull-down-Schaltung (300, 350, D1) eine FET-Schaltung, eine Transistorschaltung, eine Diodenschaltung, einen Relaischalter und/oder einen MEMS-Schalter umfasst, der das Herabsetzen bereitstellt.

15. Verfahren nach Anspruch 13 oder Anspruch 14, wobei die Vorrichtung (104) als ein Leistungsverbraucher fungiert, wenn sich die Vorrichtung (104) im Abschaltmodus befindet, eine leere Batterie aufweist und/oder keine Batterie aufweist.

Revendications

1. Appareil (104) comprenant :

un circuit de rappel vers le niveau bas (300, 350, D1) dans l'appareil (104), agissant comme un consommateur de puissance lorsqu'il n'y a pas d'énergie dans l'appareil (104), le circuit de rappel vers le niveau bas (300, 350, D1) pouvant être connecté par l'intermédiaire d'une ligne de configuration (CC) sur un câble (130) à un dispositif fournisseur d'énergie (102), le circuit de rappel vers le niveau bas (300, 350, D1) étant conçu pour utiliser l'énergie de la ligne de configuration (CC) afin de ramener une tension vers le niveau bas sur la ligne de configuration (CC), et pour signaler le dispositif fournisseur de puissance (102) à l'appareil (104) pour fournir une puissance sur une autre ligne (VBUS) du câble (130).

2. Appareil (104) selon la revendication 1, l'appareil (104) étant un dispositif avec un port à double rôle, le circuit de rappel vers le niveau bas (300, 350) étant connecté par l'intermédiaire d'une ligne de canal de configuration sur un câble C de type USB au dispositif fournisseur de puissance (102), et l'autre ligne du câble étant une ligne VBUS du câble C de type USB connectée au dispositif fournisseur de puissance (102).

3. Appareil (104) selon la revendication 1 ou 2, dans lequel le circuit de rappel vers le niveau bas (300, 350, D1) comprend un circuit de FET, un circuit de transistors, un circuit de diodes, un relais commutateur ou un commutateur MEMS qui assure le rappel vers le niveau bas.

4. Appareil (104) selon l'une quelconque des revendications précédentes, dans lequel le circuit de rappel vers le niveau bas (300) comprend en outre :

un FET à canal N, dont la grille est couplée par l'intermédiaire d'une résistance (R2) à la ligne de canal de configuration (CC) du câble (130), dont la source est connectée à un potentiel à la terre, et dont le drain est connecté à la ligne de canal de configuration (CC) du câble (130), le FET à canal N étant conçu pour devenir plus conducteur de manière à réduire la tension sur la ligne de canal de configuration (CC) du câble (130), de manière à signaler le dispositif fournisseur de puissance (102) sur la ligne de canal de configuration (CC) afin de fournir une puissance à l'appareil (104) sur la ligne VBUS du câble (130).

5. Appareil (104) selon l'une quelconque des revendications précédentes, dans lequel le circuit de rappel vers le niveau bas (350) comprend en outre :

un FET à canal P, dont la grille est couplée par l'intermédiaire d'une résistance (R1) à un potentiel à la terre, dont le drain est connecté à un potentiel à la terre, et dont la source est connectée à la ligne de canal de configuration (CC) du câble (130), le FET à canal P étant conçu pour être conducteur par l'intermédiaire de son chemin source-drain de manière à réduire la tension sur la ligne de canal de configuration (CC) du câble (130), de manière à signaler le dispositif fournisseur de puissance (102) sur la ligne de canal de configuration (CC) afin de fournir une puissance à l'appareil (104) sur la ligne VBUS du câble (130).

6. Appareil (104) selon l'une quelconque des revendications précédentes, dans lequel le circuit de rappel vers le niveau bas comprend en outre :

- une diode (D1), dont la cathode est couplée par l'intermédiaire d'une résistance à un potentiel à la terre, et dont l'anode est connectée à la ligne de canal de configuration (CC) du câble (130), la diode (D1) étant conçue pour être conductrice de manière à réduire la tension sur la ligne de canal de configuration (CC) du câble (130), de manière à signaler le dispositif fournisseur de puissance (102) sur la ligne de canal de configuration (CC) afin de fournir une puissance à l'appareil (104) sur la ligne VBUS du câble (130).
7. Appareil (104) selon l'une quelconque des revendications précédentes, l'appareil étant un dispositif avec un port à rôle de dispositif, le circuit de rappel vers le niveau bas (300, 350, D1) étant connecté par l'intermédiaire d'une ligne de canal de configuration sur un câble C de type USB au dispositif fournisseur de puissance (102), et l'autre ligne du câble étant une ligne VBUS du câble C de type USB connectée au dispositif fournisseur de puissance (102).
8. Appareil (104) selon l'une quelconque des revendications précédentes, l'appareil (104) agissant comme un consommateur de puissance lorsqu'il est en mode hors tension.
9. Appareil (104) selon l'une quelconque des revendications précédentes, l'appareil (104) agissant comme un consommateur de puissance lorsque sa batterie est vide ou qu'il n'a pas de batterie.
10. Appareil (104) selon la revendication 1, dans lequel :
- le circuit de rappel vers le niveau bas (300, 350, D1) dans l'appareil (104) a un port à double rôle agissant comme consommateur de puissance lorsqu'il n'y a pas d'énergie dans l'appareil ; la ligne de configuration (CC) est une ligne de canal de configuration ; le câble (130) est un câble C de type USB ; et le dispositif fournisseur de puissance (102) est signalé pour fournir une puissance sur une ligne VBUS du câble C de type USB à l'appareil (104).
11. Appareil (104) selon la revendication 10, l'appareil (104) comprenant une batterie qui devient chargée par la puissance fournie sur la ligne VBUS, et dans lequel, en réponse, le circuit de rappel vers le niveau bas (300, 350, D1) arrête de rappeler vers le niveau bas la tension de la ligne de canal de configuration et libère le contrôle du canal de configuration vers d'autres circuits ayant une capacité de prendre des décisions logiques.
12. Appareil (104) selon la revendication 10 ou 11, l'appareil (104) agissant comme un consommateur de puissance lorsque l'appareil (104) est en mode hors
- tension, lorsque sa batterie est vide et lorsqu'il n'a pas de batterie.
13. Procédé comprenant les étapes consistant à :
- régler un circuit de rappel vers le niveau bas (300, 350, D1) dans un appareil (104), agissant comme un consommateur de puissance lorsqu'il n'y a pas d'énergie dans l'appareil (104), le circuit de rappel vers le niveau bas (300, 350, D1) pouvant être connecté par l'intermédiaire d'une ligne de configuration (CC) sur un câble (130) à un dispositif fournisseur d'énergie (102) pour utiliser l'énergie de la ligne de configuration (CC) afin de ramener une tension vers le niveau bas sur la ligne de configuration (CC), et pour signaler le dispositif fournisseur de puissance (102) à l'appareil (104) pour fournir une puissance sur une autre ligne (VBUS) du câble (130).
14. Procédé selon la revendication 13, dans lequel le circuit de rappel vers le niveau bas (300, 350, D1) comprend un circuit de FET, un circuit de transistors, un circuit de diodes, un relais commutateur et/ou un commutateur MEMS qui assure le rappel vers le niveau bas.
15. Procédé selon la revendication 13 ou 14, dans lequel l'appareil (104) agit comme un consommateur de puissance lorsque l'appareil (104) est en mode hors tension, lorsque sa batterie est vide et lorsqu'il n'a pas de batterie.

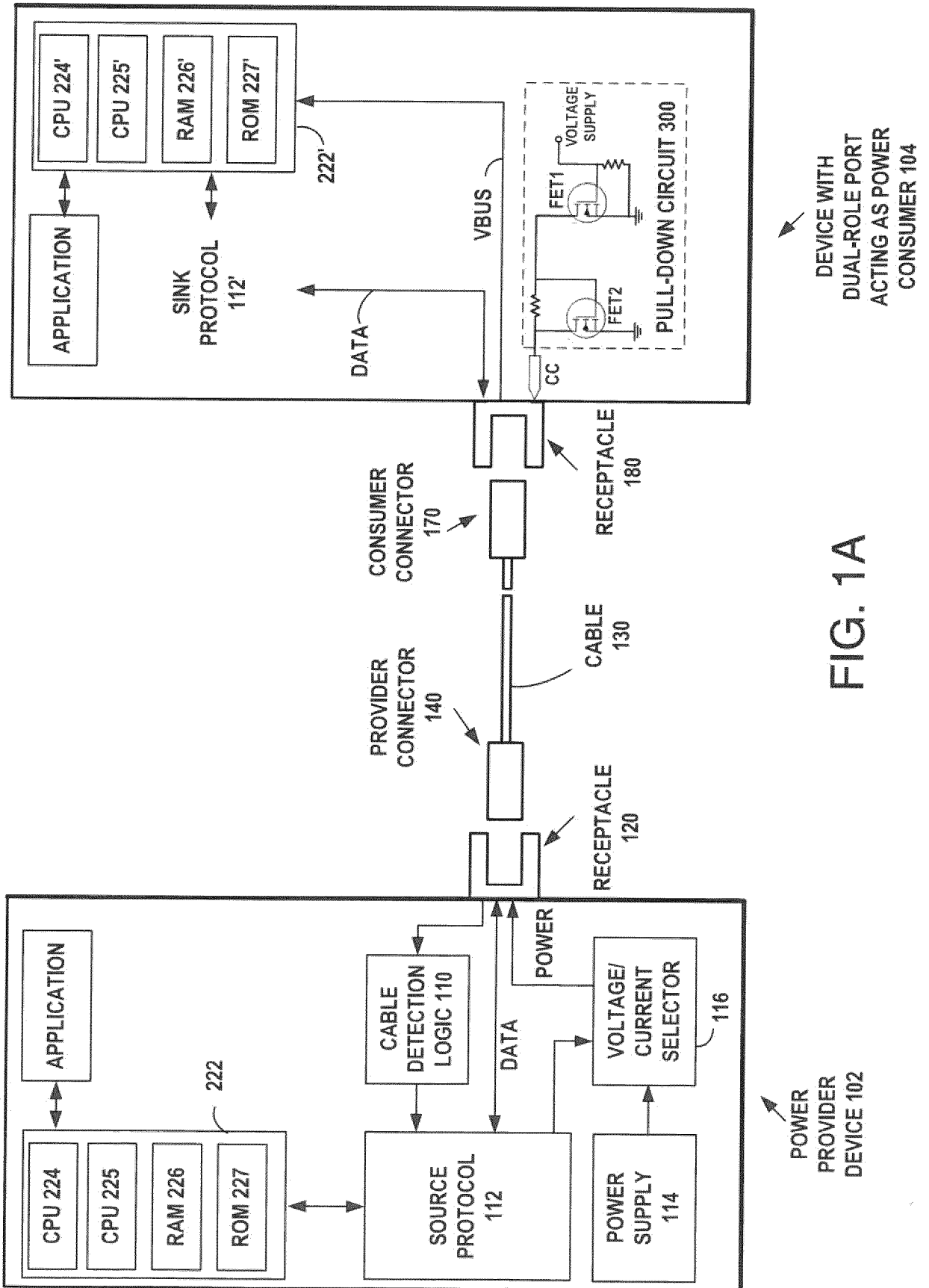

Connector
140 or 170

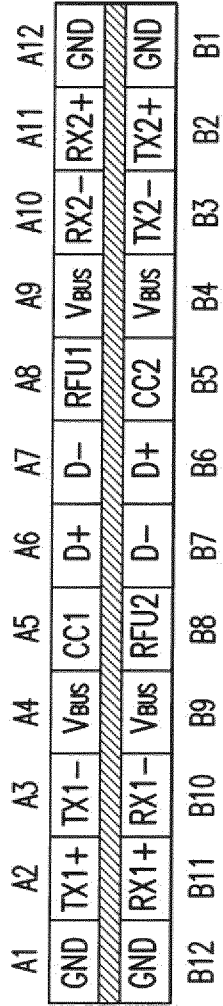



FIG. 1B

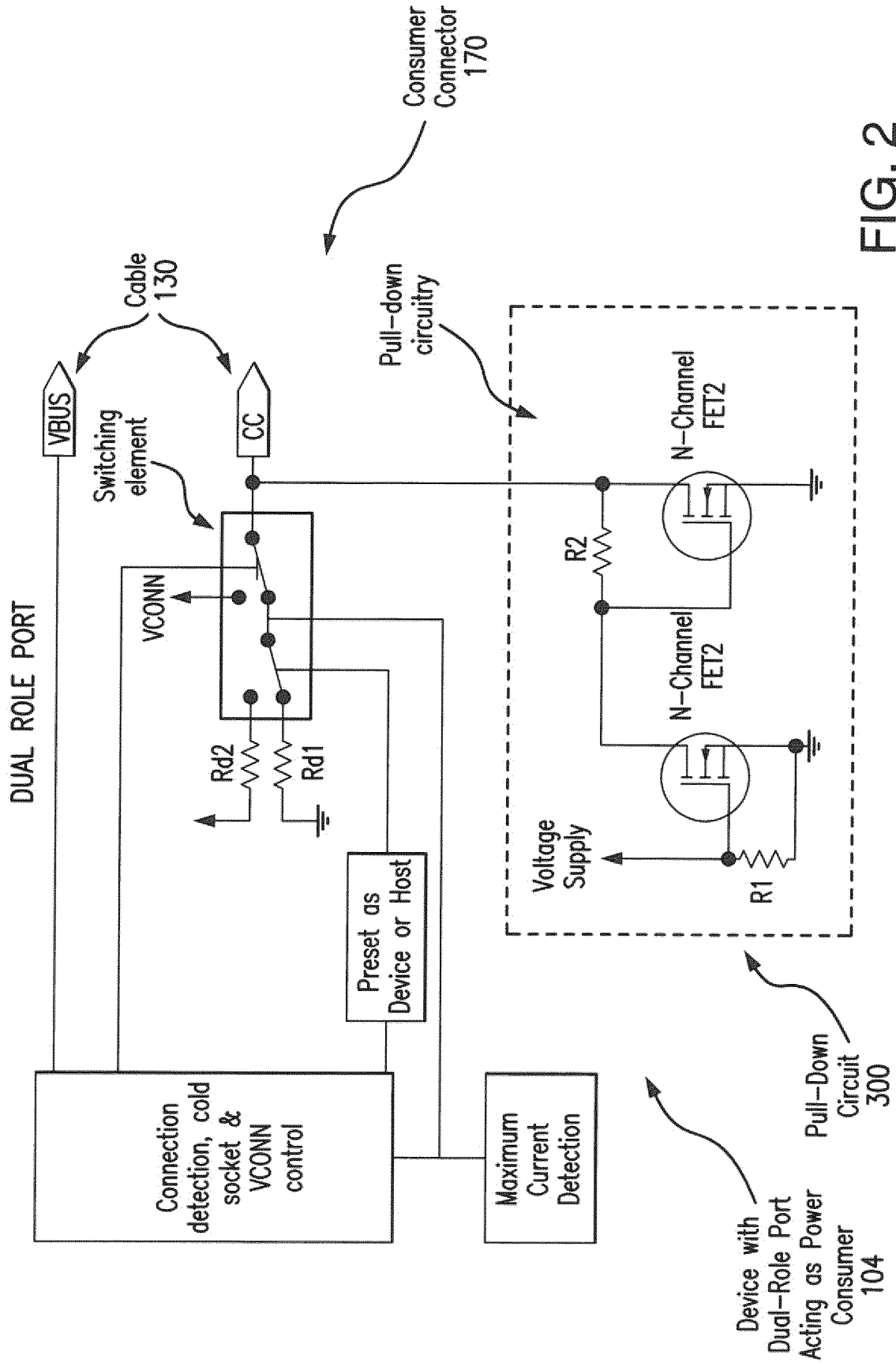

FIG. 2

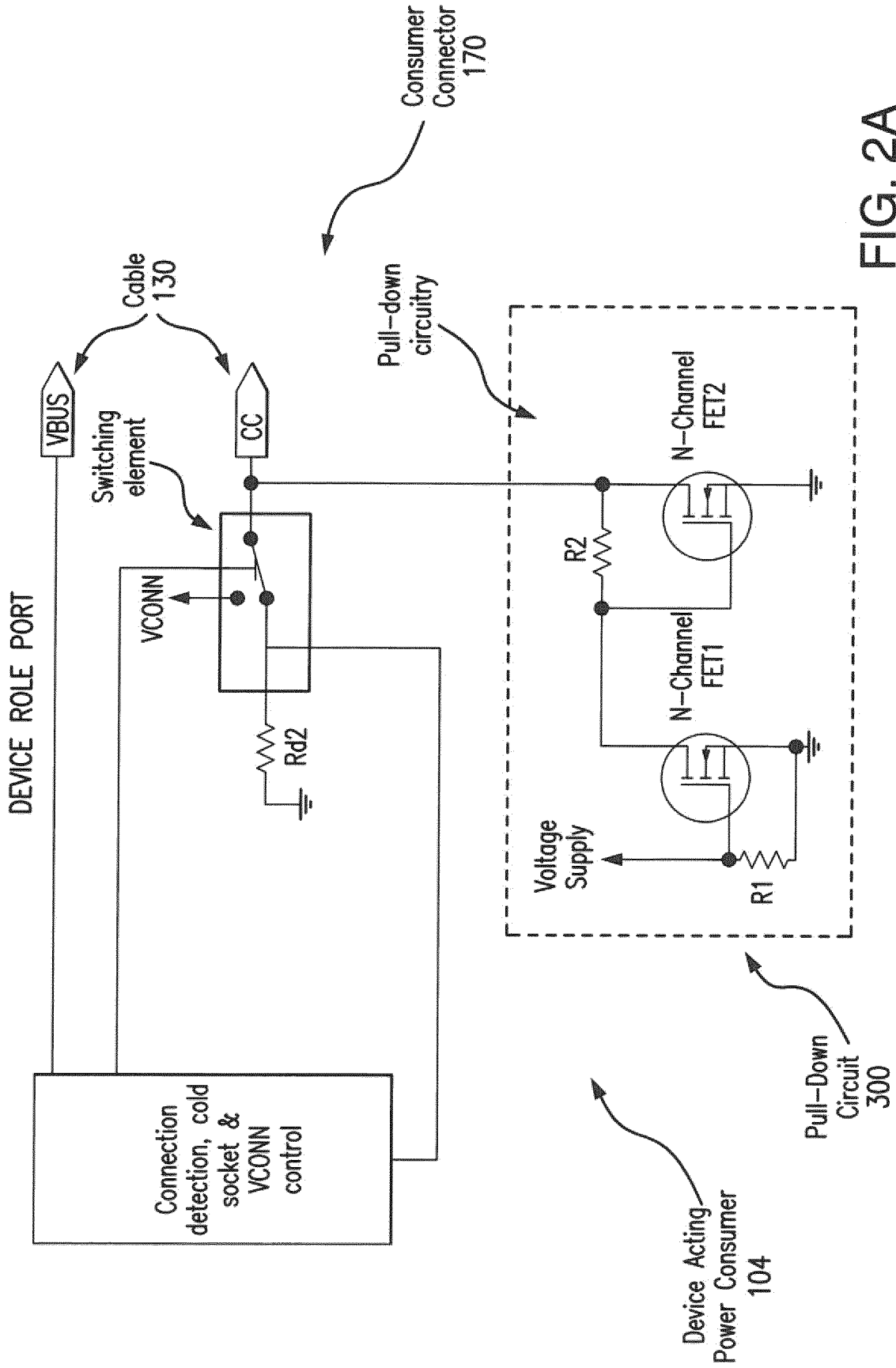

FIG. 2A

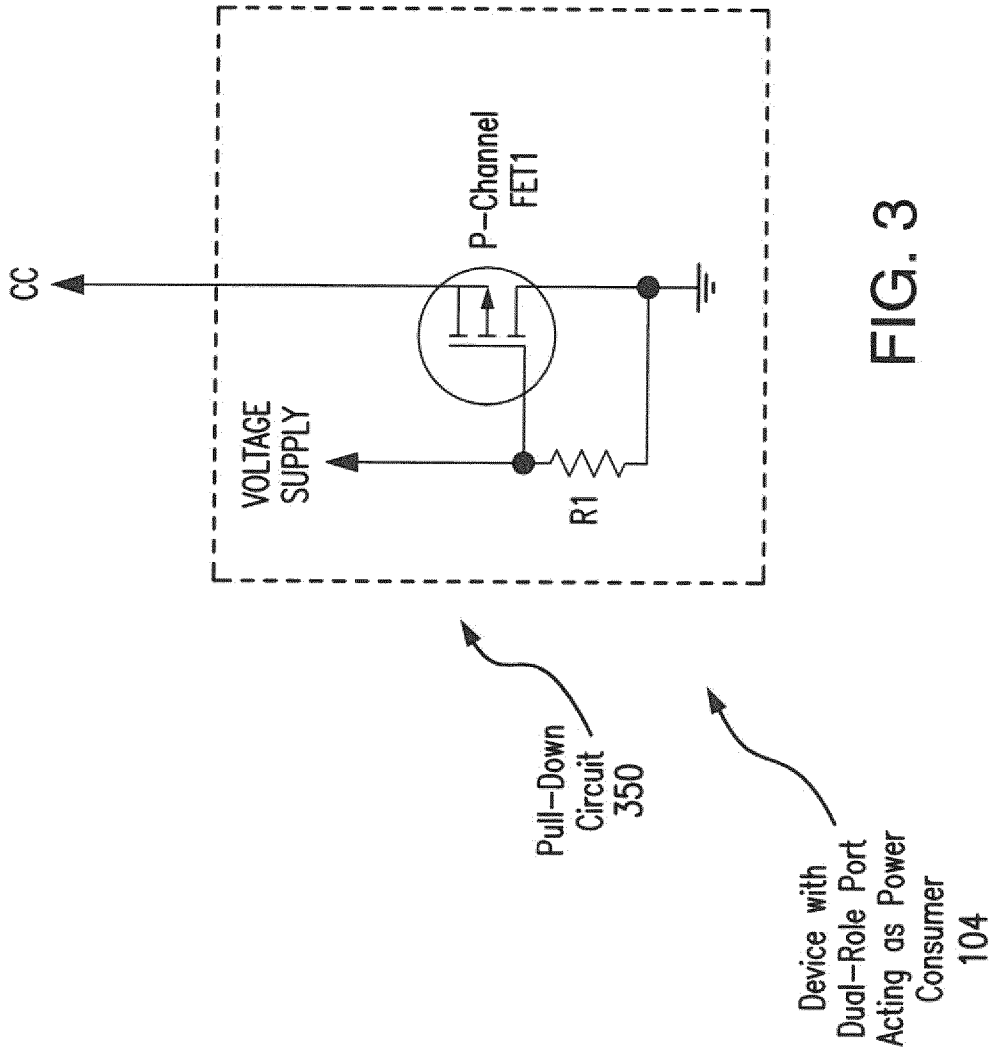

FIG. 3

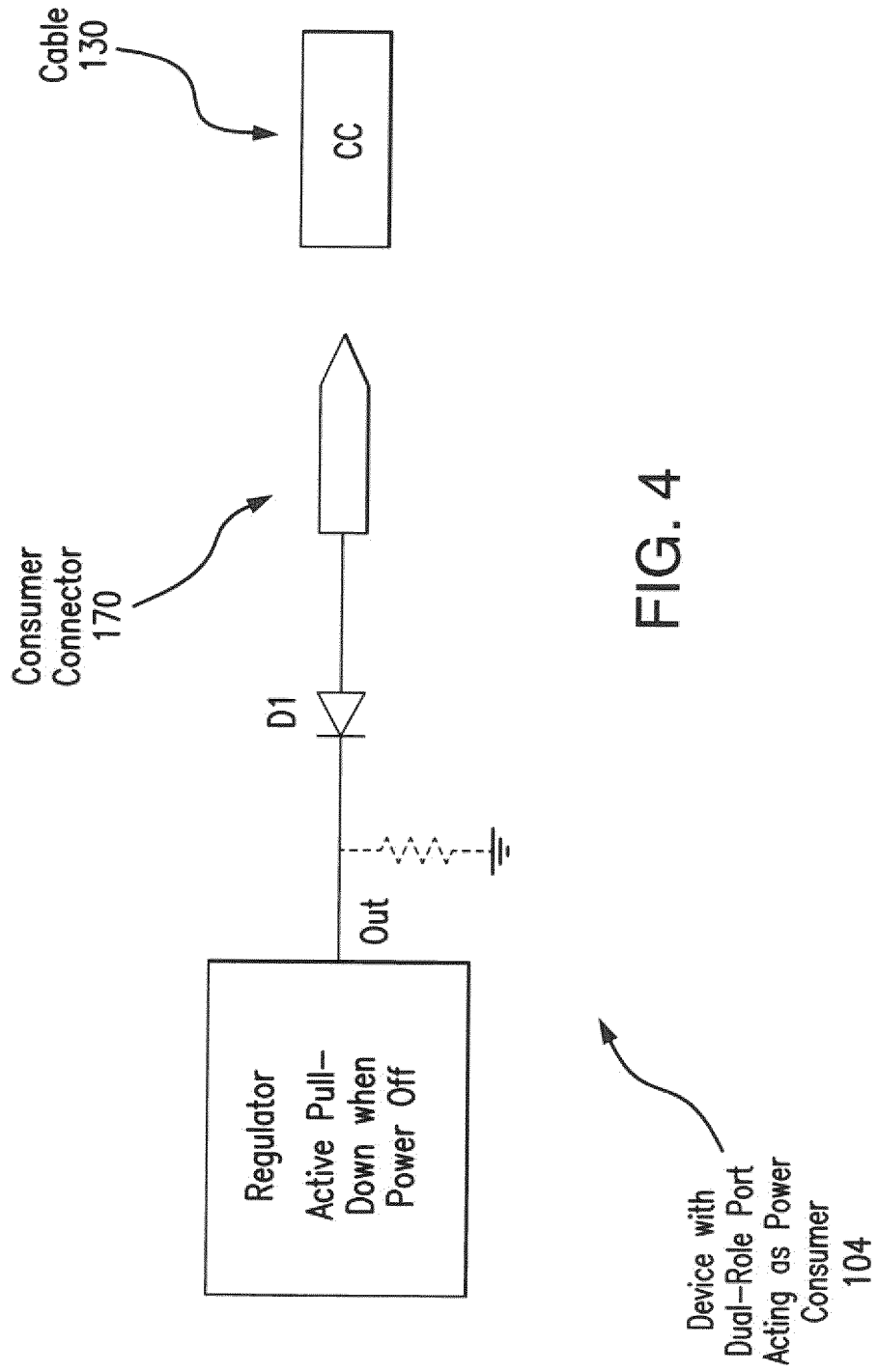

FIG. 4

REFERENCES CITED IN THE DESCRIPTION

This list of references cited by the applicant is for the reader's convenience only. It does not form part of the European patent document. Even though great care has been taken in compiling the references, errors or omissions cannot be excluded and the EPO disclaims all liability in this regard.

Patent documents cited in the description

- WO 2008146073 A1 [0003]
- US 2008247104 A1 [0004]

Lehúzó áramkör egy berendezéshez

Szabadalmi igénypontok



1. Berendezés (104), amely tartalmaz:

egy lehúzó áramkört (300, 350, D1) a berendezésben (104), amely energia fogyasztóként működik, ha nincs energia a berendezésben (104), a lehúzó áramkör (300, 350, D1) egy konfigurációs vonallal (CC) egy kábelen (130) keresztül egy energiaellátó készülékhez (102) csatlakoztatható, a lehúzó áramkör (300, 350, D1) úgy van konfigurálva, hogy energiát használjon a konfigurációs vonaltól (CC), hogy lehúzza a konfigurációs vonal (CC) feszültségét, hogy jelezze a energiaellátó készülék (102) felé, hogy biztosítson energiát a kábel (130) másik vezetékén (VBUS) keresztül a berendezésnek (104).

2. Az 1. igénypont szerinti berendezés (104), ahol a berendezés egy Dual-Role Port-tal rendelkező készülék, a lehúzó áramkör (300, 350) egy konfigurációs csatorna vonallal egy USB-Type C kábelen keresztül van az energiaellátó készülékhez (102) csatlakoztatva, és a kábel egy másik vezetéke az USB-Type C kábel egy VBUS vezetéke az energiaellátó készülékhez (102).

3. Az 1. vagy 2. igénypont szerinti berendezés (104), ahol a lehúzó áramkör (300, 350, D1) egy FET áramkör, tranzisztor áramkör, dióda áramkör, jelfogó kapcsoló, vagy a lehúzást biztosító MEMS kapcsoló legalább egyikét tartalmazza.

4. Az előző igénypontok bármelyike szerinti berendezés (104), ahol a lehúzó áramkör (300) tartalmaz továbbá: egy N-csatornás FET-et, amelynek kapuja egy ellenálláson (R2) át a kábel (130) konfigurációs csatorna vonalára (CC) van csatlakoztatva, forrása testpotenciálra van kötve, és nyelője a kábel (130) konfigurációs csatorna vonalához (CC) van csatlakoztatva, az N-csatornás FET úgy van konfigurálva, hogy jobban vezetővé váljon, csökkentve ezzel a feszültséget a kábel (130) konfigurációs csatorna vonalán (CC), így módon jelezve a energiaellátó készüléknek (102) a konfigurációs csatorna vonalon (CC) át, hogy a kábel (130) VBUS vezetékén át szolgáltatasson energiát a berendezés (104) számára.

5. Az előző igénypontok bármelyike szerinti berendezés (104), ahol a lehúzó áramkör (350) tartalmaz továbbá: egy P-csatornás FET-et, amelynek kapuja egy ellenálláson (R1) át testpotenciálra van kötve, nyelője testpotenciálra van kötve, forrása pedig a kábel (130) konfigurációs csatorna vonalára (CC) van kötve, a P-csatornás FET úgy van konfigurálva, hogy vezessen a forrás-nyelő útvonalon át, így módon csökkentve a feszültséget a kábel (130) konfigurációs csatorna vonalán (CC), így módon jelezve a energiaellátó készüléknek (102) a konfigurációs csatorna vonalon (CC) át, hogy a kábel (130) VBUS vezetékén át szolgáltatasson energiát a berendezés (104) számára.

6. Az előző igénypontok bármelyike szerinti berendezés (104), ahol a lehúzó áramkör tartalmaz továbbá: diódát (D1), amelynek katódja egy ellenálláson át testpotenciálra van kötve és anódja a kábel (130) konfigurációs csatorna vonalára (CC) van csatlakoztatva, a dióda (D1) úgy van konfigurálva, hogy vezessen, így módon csökkentve a feszültséget a kábel (130) konfigurációs csatorna vonalán (CC), ezzel jelezve a energiaellátó készü-

léknek (102) a konfigurációs csatorna vonalon (CC) át, hogy a kábel (130) VBUS vezetékén át szolgáltatson energiát a berendezés (104) számára.

7. Az előző igénypontok bármelyike szerinti berendezés (104), ahol a berendezés egy Device-Role Port-ot tartalmazó készülék, a lehúzó áramkör (300, 350, D1) egy konfigurációs csatorna vonallal egy USB-Type C kábelen át a energiaellátó készülékhez (102) van csatlakoztatva, és a kábel egy második vezetéke az USB-Type C kábel egy VBUS vezetéke a energiaellátó készülékhez (102).

8. Az előző igénypontok bármelyike szerinti berendezés (104), ahol a berendezés (104) energia fogyasztóként működik, ha kikapcsolt állapotú.

9. Az előző igénypontok bármelyike szerinti berendezés (104), ahol a berendezés (104) energia fogyasztóként működik, ha akkumulátora lemerült vagy akkumulátora hiányzik.

10. Az előző igénypontok bármelyike szerinti berendezés (104), ahol:

a lehúzó áramkör (300, 350, D1) a berendezésben egy Dual-Role Port-tal rendelkezik, amely energia fogyasztóként működik, ha nincs energia a berendezésben;

a konfigurációs vonal (CC) egy konfigurációs csatorna vonal;

a kábel (130) egy USB-Type C kábel; és

az energiaellátó készülék (102) jelzést kap, hogy szolgáltatasson energiát az USB-Type C kábel VBUS vezetékén át a berendezésnek (104).

11. A 10. igénypont szerinti berendezés (104), ahol a berendezés (104) akkumulátort tartalmaz, amelyet a VBUS vezetékén át szolgáltatott energia tölt, és válaszképpen a lehúzó áramkör (300, 350, D1) abbahagyja a konfigurációs csatorna vonal feszültségének lehúzását és a konfigurációs csatorna vezérlését átengedi más, logikai döntési képességgel rendelkező áramkör számára.

12. A 10. vagy 11. igénypont szerinti berendezés (104), ahol a berendezés energia fogyasztóként működik, ha a berendezés (104) kikapcsolt üzemmód, lemerült akkumulátor és akkumulátorhiány legalább egyikében található.

13. Eljárás, amely tartalmazza:

egy lehúzó áramkör (300, 350, D1) beállítását egy berendezésbe (104), amely energia fogyasztóként működik, ha nincs energia a berendezésben (104), a lehúzó áramkör (300, 350, D1) egy konfigurációs vonallal (CC) egy kábelen (130) át egy energiaellátó készülékhez (102) csatlakoztatható, hogy energiát használjon a konfigurációs vonalból (CC), hogy lehúzza a konfigurációs vonal (CC) feszültségét, hogy jelezze a energiaellátó készülék (102) felé, hogy a kábel (130) egy másik vezetékén (VBUS) át szolgáltatasson energiát a berendezés (104) számára.

14. A 13. igénypont szerinti eljárás, ahol a lehúzó áramkör (300, 350, D1) FET áramkör, tranzisztoros áramkör, dióda áramkör, jelfogó kapcsoló vagy a lehúzást biztosító MEMS kapcsoló legalább egyikét tartalmazza.

15. A 13. vagy 14. igénypont szerinti eljárás, ahol a berendezés energia fogyasztóként működik, ha a berendezés kikapcsolt üzemmód, lemerült akkumulátor vagy akkumulátor nélküli állapot legalább egyikében található.