



US010893587B2

(12) **United States Patent**  
**Halliwell**

(10) **Patent No.:** **US 10,893,587 B2**

(45) **Date of Patent:** **Jan. 12, 2021**

(54) **LIGHT EMITTING DIODE (LED) LIGHTING DEVICE OR LAMP WITH CONFIGURABLE LIGHT QUALITIES**

(56) **References Cited**

U.S. PATENT DOCUMENTS

(71) Applicant: **Feit Electric Company, Inc.**, Pico Rivera, CA (US)

6,127,783 A 10/2000 Pashley et al.  
6,149,283 A \* 11/2000 Conway ..... F21V 29/763 362/236

(Continued)

(72) Inventor: **Brian Halliwell**, Pico Rivera, CA (US)

FOREIGN PATENT DOCUMENTS

(73) Assignee: **Feit Electric Company, Inc.**, Pico Rivera, CA (US)

CN 201844227 U 5/2011  
CN 204069421 U 12/2014

(Continued)

(\* ) Notice: Subject to any disclaimer, the term of this patent is extended or adjusted under 35 U.S.C. 154(b) by 0 days.

OTHER PUBLICATIONS

(21) Appl. No.: **16/001,260**

Coolux, "Once Again Another Technology Breakthrough of LED Edgt-Lit Panel: The DIP-DIM Panel, 4 Wattage & 3 Color Switchable 130 LM/W", brochure distributed at LIGHTFAIR International 2016 Booth #1111, Apr. 26-28, 2016, 4 pages, San Diego, California.

(Continued)

(22) Filed: **Jun. 6, 2018**

(65) **Prior Publication Data**

US 2018/0288847 A1 Oct. 4, 2018

**Related U.S. Application Data**

*Primary Examiner* — Jason Crawford

(74) *Attorney, Agent, or Firm* — Alston & Bird LLP

(63) Continuation-in-part of application No. 15/705,808, filed on Sep. 15, 2017, now Pat. No. 10,104,742, (Continued)

(57) **ABSTRACT**

(51) **Int. Cl.**  
**H05B 45/20** (2020.01)  
**F21K 9/238** (2016.01)  
(Continued)

An LED lighting device or LED lamp comprising one or more LED packages; and a switch control unit is provided. The switch control unit is configured to operate the one or more LED packages. The switch control unit is in communication with a sensor located in a space, the LED lighting device or LED lamp also being located in the space. The switch control unit is configured to (i) receive a sensor signal from the sensor, (ii) process the sensor signal, (iii) determine an adjustment to the operating light qualities of the LED lighting device or LED lamp based on the processing of the sensor signal and one or more goal light qualities corresponding to the space, and (iv) adjust the operation of the one or more LED packages in accordance with the adjustment.

(52) **U.S. Cl.**  
CPC ..... **H05B 45/20** (2020.01); **F21K 9/232** (2016.08); **F21K 9/235** (2016.08); **F21K 9/237** (2016.08);  
(Continued)

(58) **Field of Classification Search**  
CPC ..... H05B 33/0854; H05B 33/0857; H05B 33/086; H05B 45/10; H05B 45/12;  
(Continued)

**20 Claims, 13 Drawing Sheets**

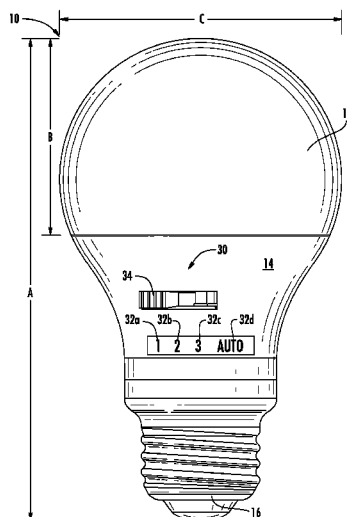

**Related U.S. Application Data**

which is a continuation of application No. 15/274,575, filed on Sep. 23, 2016, now Pat. No. 9,801,250.

(51) **Int. Cl.**

**F21K 9/232** (2016.01)  
**F21K 9/65** (2016.01)  
**F21K 9/235** (2016.01)  
**F21K 9/237** (2016.01)  
**F21V 19/00** (2006.01)  
**F21V 23/00** (2015.01)  
**F21V 23/04** (2006.01)  
**F21V 29/70** (2015.01)  
**H05B 45/10** (2020.01)  
**H05B 47/19** (2020.01)  
**H05B 39/08** (2006.01)  
**F21V 3/00** (2015.01)  
**F21Y 115/10** (2016.01)  
**F21Y 113/13** (2016.01)

8,378,588 B2 2/2013 Kuo et al.  
 8,378,589 B2 2/2013 Kuo et al.  
 8,430,402 B2 4/2013 Diehl et al.  
 8,482,219 B2 7/2013 Kuo et al.  
 8,508,150 B2 8/2013 Kuo et al.  
 8,598,793 B2 12/2013 Yan et al.  
 8,664,895 B2 3/2014 Yan et al.  
 8,669,722 B2 3/2014 Yeh et al.  
 8,729,812 B2 5/2014 Kuwu  
 8,853,950 B1\* 10/2014 Chang ..... H05B 47/10  
 315/127

(52) **U.S. Cl.**

CPC ..... **F21K 9/238** (2016.08); **F21K 9/65** (2016.08); **F21V 19/006** (2013.01); **F21V 23/003** (2013.01); **F21V 23/04** (2013.01); **F21V 29/70** (2015.01); **H05B 45/10** (2020.01); **H05B 47/19** (2020.01); **F21V 3/00** (2013.01); **F21Y 2113/13** (2016.08); **F21Y 2115/10** (2016.08); **H05B 39/088** (2013.01); **Y02B 20/30** (2013.01)

8,872,438 B2 10/2014 Zhou et al.  
 8,884,508 B2 11/2014 Pickard et al.  
 8,890,440 B2 11/2014 Yan et al.  
 8,941,312 B2 1/2015 McRae  
 8,947,013 B2 2/2015 Sutardja et al.  
 9,030,122 B2 5/2015 Yan et al.  
 9,072,148 B2 6/2015 Tanaka et al.  
 9,119,252 B2 8/2015 Wu  
 9,144,129 B2 9/2015 Munday  
 9,232,591 B2 1/2016 Kuo et al.  
 9,232,602 B2 1/2016 Yeh et al.  
 9,253,843 B2 2/2016 Lee et al.  
 9,386,653 B2 7/2016 Kuo et al.  
 9,441,801 B1 9/2016 Myers et al.  
 9,642,208 B2 5/2017 Van De Ven  
 9,713,211 B2 7/2017 Van De Ven et al.  
 9,730,291 B1 8/2017 Janik et al.  
 9,781,793 B2 10/2017 Yan et al.  
 9,786,639 B2 10/2017 Bergmann et al.  
 9,799,125 B1 10/2017 Wegner et al.  
 9,801,250 B1 10/2017 Halliwell  
 9,820,350 B2 11/2017 Pyshos et al.  
 9,892,693 B1 2/2018 Kumar et al.  
 9,900,945 B1 2/2018 Janik et al.  
 9,909,723 B2 3/2018 Bergmann et al.  
 9,924,582 B2 3/2018 Vendetti et al.  
 9,974,138 B2 5/2018 Allen et al.  
 10,008,484 B2 6/2018 Bergmann et al.  
 10,009,971 B2 6/2018 Chobot et al.  
 10,018,346 B2 7/2018 Van De Ven et al.  
 10,076,011 B1 9/2018 Amidi et al.  
 10,091,855 B2 10/2018 Van Winkle  
 10,104,742 B2 10/2018 Halliwell  
 10,136,503 B2 11/2018 Chen  
 10,163,405 B2 12/2018 Kumar et al.  
 10,231,300 B2 3/2019 Cash et al.  
 10,278,250 B2 4/2019 McBryde et al.  
 10,290,265 B2 5/2019 Kumar et al.  
 10,299,335 B2 5/2019 Pyshos et al.  
 10,299,336 B2 5/2019 Bowen et al.  
 10,334,678 B2 6/2019 Janik et al.  
 10,462,871 B2 10/2019 Van Winkle  
 10,492,262 B2 11/2019 Van Winkle  
 10,602,584 B2 3/2020 Pyshos et al.  
 10,683,969 B2\* 6/2020 Jeswani ..... F21K 9/278

(58) **Field of Classification Search**

CPC ..... H05B 45/20; H05B 45/22; H05B 45/30; H05B 45/40; H05B 47/10; H05B 47/105; H05B 47/11; H05B 47/14; H05B 47/155; H05B 47/17; F21K 9/23; F21K 9/238; F21K 9/65

See application file for complete search history.

(56) **References Cited**

U.S. PATENT DOCUMENTS

6,201,351 B1 3/2001 Rudolph et al.  
 6,357,889 B1 3/2002 Duggal et al.  
 6,834,981 B2 12/2004 Nagai et al.  
 7,014,336 B1 3/2006 Ducharme et al.  
 7,083,293 B2 8/2006 Kalinski  
 7,201,489 B2 4/2007 Shyu  
 7,255,457 B2 8/2007 Ducharme et al.  
 7,288,902 B1 10/2007 Melanson  
 7,405,715 B2 7/2008 Guzman et al.  
 7,416,312 B1 8/2008 McDermott  
 7,484,860 B2 2/2009 Demarest et al.  
 7,520,634 B2 4/2009 Ducharme et al.  
 7,521,667 B2\* 4/2009 Rains, Jr. .... F21V 7/24  
 250/228  
 7,659,674 B2 2/2010 Mueller et al.  
 7,883,239 B2 2/2011 Rains, Jr. et al.  
 7,926,300 B2 4/2011 Roberts et al.  
 7,988,327 B1 8/2011 Knoble et al.  
 8,044,608 B2 10/2011 Kuo et al.  
 8,076,867 B2 12/2011 Kuo et al.  
 8,111,017 B2 2/2012 Lin et al.  
 8,159,125 B2 4/2012 Miao  
 8,172,415 B2 5/2012 Wegh et al.  
 8,207,821 B2 6/2012 Roberge et al.  
 8,220,970 B1 7/2012 Khazi et al.  
 8,305,013 B2 11/2012 Lin et al.  
 8,314,571 B2 11/2012 Jonsson  
 8,317,362 B2 11/2012 Ku et al.  
 8,330,388 B2 12/2012 Kuo et al.  
 8,339,063 B2 12/2012 Yan et al.  
 8,339,067 B2 12/2012 Lin et al.

10,076,011 B1 9/2018 Amidi et al.  
 10,091,855 B2 10/2018 Van Winkle  
 10,104,742 B2 10/2018 Halliwell  
 10,136,503 B2 11/2018 Chen  
 10,163,405 B2 12/2018 Kumar et al.  
 10,231,300 B2 3/2019 Cash et al.  
 10,278,250 B2 4/2019 McBryde et al.  
 10,290,265 B2 5/2019 Kumar et al.  
 10,299,335 B2 5/2019 Pyshos et al.  
 10,299,336 B2 5/2019 Bowen et al.  
 10,334,678 B2 6/2019 Janik et al.  
 10,462,871 B2 10/2019 Van Winkle  
 10,492,262 B2 11/2019 Van Winkle  
 10,602,584 B2 3/2020 Pyshos et al.  
 10,683,969 B2\* 6/2020 Jeswani ..... F21K 9/278  
 2002/0048169 A1 4/2002 Dowling et al.  
 2002/0071279 A1 6/2002 Katogi et al.  
 2004/0264187 A1 12/2004 Vanderschuit  
 2005/0012457 A1 1/2005 Wu  
 2005/0077837 A1 4/2005 Kim et al.  
 2005/0128751 A1 6/2005 Roberge et al.  
 2005/0270780 A1 12/2005 Zhang  
 2005/0285547 A1 12/2005 Piepgras et al.  
 2006/0220586 A1 10/2006 Latham  
 2006/0237636 A1 10/2006 Lyons et al.  
 2006/0238136 A1 10/2006 Johnson, III et al.  
 2007/0247840 A1 10/2007 Ham  
 2007/0273290 A1\* 11/2007 Ashdown ..... F21V 29/717  
 315/113  
 2008/0060917 A1 3/2008 Chen et al.  
 2008/0106893 A1 5/2008 Johnson et al.  
 2009/0052170 A1 2/2009 Jeng et al.  
 2010/0237798 A1 9/2010 Wolf et al.  
 2010/0328946 A1 12/2010 Borkar et al.  
 2011/0193479 A1 8/2011 Nilssen et al.  
 2012/0306377 A1\* 12/2012 Igaki ..... F21V 23/0464  
 315/151  
 2012/0327660 A1 12/2012 Lin

(56)

References Cited

U.S. PATENT DOCUMENTS

2013/0003417	A1	1/2013	Chien et al.	
2013/0038244	A1*	2/2013	Kamii .....	H05B 45/20 315/297
2013/0114241	A1	5/2013	Van De Ven et al.	
2013/0147359	A1	6/2013	Chobot	
2013/0154510	A1	6/2013	Sutardja et al.	
2013/0201668	A1	8/2013	Chien et al.	
2013/0270999	A1*	10/2013	Ramer .....	F21V 3/00 315/51
2013/0328503	A1	12/2013	Toda	
2014/0049972	A1	2/2014	Mcguire et al.	
2014/0070700	A1*	3/2014	Genthon .....	H05B 33/0854 315/83
2014/0184080	A1	7/2014	Rybicki et al.	
2014/0210357	A1	7/2014	Yan et al.	
2014/0210376	A1	7/2014	Hicks, IV	
2014/0239811	A1	8/2014	Kreiner	
2014/0361696	A1	12/2014	Siessegger et al.	
2014/0364219	A1*	12/2014	Matsushita .....	G07F 17/3211 463/31
2015/0029712	A1	1/2015	Nakamura et al.	
2015/0048758	A1	2/2015	Carrigan et al.	
2015/0054410	A1	2/2015	Sanders et al.	
2015/0070897	A1	3/2015	Chien	
2015/0276204	A1	10/2015	Ray	
2015/0296577	A1	10/2015	Chen	
2016/0286633	A1*	9/2016	Juslen .....	H05B 45/50
2016/0316527	A1	10/2016	Allen et al.	
2017/0019973	A1	1/2017	Beck et al.	
2017/0080849	A1*	3/2017	Nogha Mbai .....	B60Q 1/1423
2017/0086265	A1	3/2017	Akiyama et al.	
2017/0105265	A1	4/2017	Sadwick	
2017/0181241	A1*	6/2017	Koo .....	H05B 33/0866
2017/0227174	A1*	8/2017	May .....	F21V 7/00
2017/0303363	A1	10/2017	Pyshos et al.	
2017/0354022	A1	12/2017	Dimberg et al.	
2018/0092183	A1	3/2018	Halliwel	
2018/0206305	A1	7/2018	Van Winkle	

FOREIGN PATENT DOCUMENTS

CN	105221949	A	1/2016
DE	202011103835	U1	12/2011
JP	2013254666	A	12/2013

OTHER PUBLICATIONS

MSI Solid State Lighting, "Introducing PowerBand™ Variable Wattage Technology", retrieved from <<https://www.1000bulbs.com/pdf/led-ipar3843101d-powerband.pdf>> on Jan. 11, 2017, 1 page.

MSI Solid State Lighting, "iPAR™ 38 with Powerband Technology", retrieved from <<https://www.1000bulbs.com/pdf/led-ipar3843101d-specs.pdf>> on Jan. 11, 2017, 2 pages.

Philips Lighting, "Philips Lighting unveils SceneSwitch—a unique LED light bulb range designed to make multi-purpose homes work harder", Jul. 12, 2016, 6 pages, retrieved from <<http://www.newsroom.lighting.philips.com/news/2016/20160712-philips-lighting-unveils-sceneswitch-a-unique-led-light-bulb-range-designed-to-make-multi-purpose-homes-work-harder.html>> on Jan. 11, 2017.

United States Patent and Trademark Office, Notice of Allowance for U.S. Appl. No. 15/274,575, dated Aug. 28, 2017, 12 pages, U.S.

United States Patent and Trademark Office, Office Action for U.S. Appl. No. 15/274,575, dated Apr. 24, 2017, 13 pages, U.S.

United States Patent and Trademark Office, Notice of Allowance for U.S. Appl. No. 15/705,808, dated Jun. 22, 2018, U.S.

United States Patent and Trademark Office, Office Action for U.S. Appl. No. 15/705,808, dated Feb. 13, 2018, U.S.

Unknown Author, "Rambus introduces LED BR30 and PAR30 with mechanically adjustable CCT—LEDs", *LEDs Magazine*, Jun. 12, 2013, 3 pages, retrieved from <<http://www.ledsmagazine.com/articles/iif/2013/06/rambus-introduces-led-br30-and-par30-with-mechanically-adjustable-cct.html>> on Jan. 11, 2017.

United States Patent and Trademark Office, Notice of Allowance for U.S. Appl. No. 16/128,162, dated Jul. 3, 2019, (10 pages), U.S.

Canadian Intellectual Property Office, Canadian Office Action for Canadian Patent Application No. 3,021,693, dated Jul. 26, 2019 (6 pages), Quebec, Canada.

United States Patent and Trademark Office, NonFinal Office Action for U.S. Appl. No. 16/545,873, dated Oct. 28, 2019, (26 pages), USA.

Hampton Bay, Use and Care Guide, LED Universal Ceiling Fan Light Kit, retrieved from <https://images.homedepot-static.com/catalog/pdfImages/8f/8fbdd564-5722-4e5d-b579-e231a0848dd5.pdf> on Jun. 12, 2020.

United States Patent and Trademark Office, Advisory Action received for U.S. Appl. No. 16/545,873, dated May 20, 2020, 6 pages, U.S.

Gisteq Corp., "GISTEQ Flashmate F-160 & F-198," YouTube, <https://www.youtube.com/watch?v=59Tf4CwF2oU>, Aug. 8, 2013.

United States Patent & Trademark Office, Office Action for U.S. Appl. No. 16/545,873, dated Jul. 27, 2020, 32 pages, USA.

\* cited by examiner

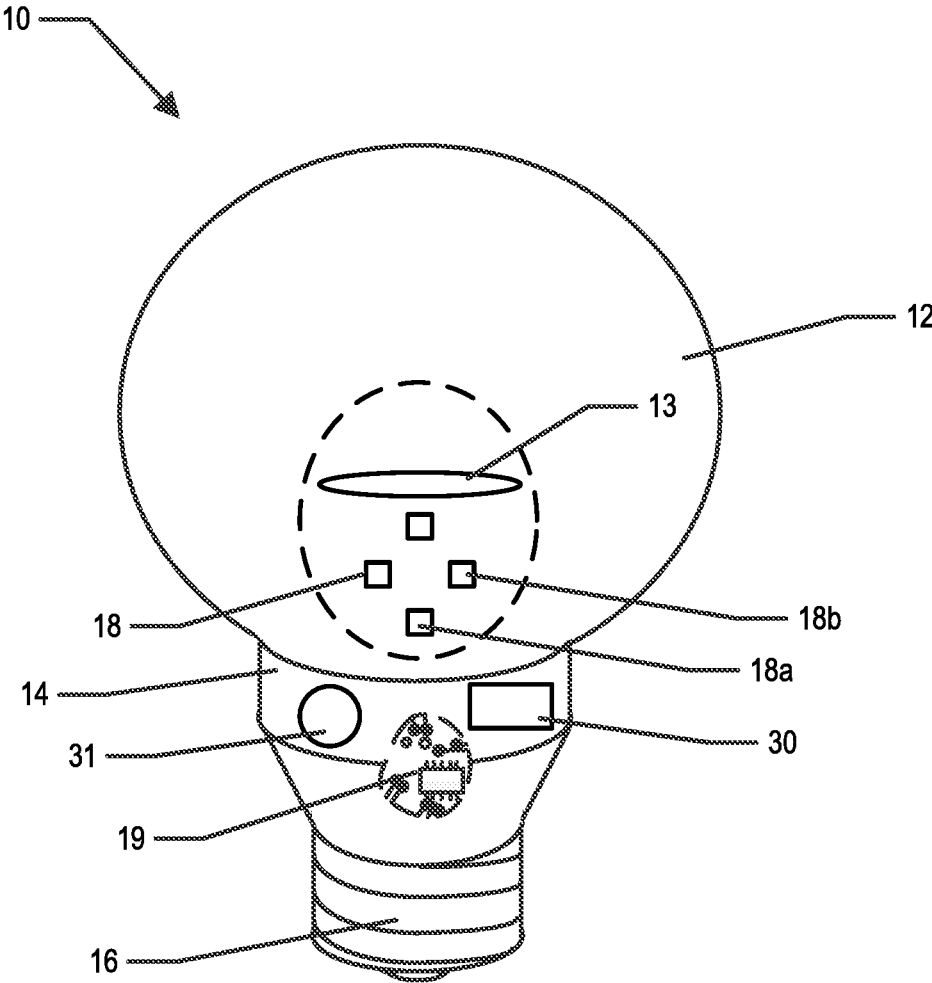

FIG. 1

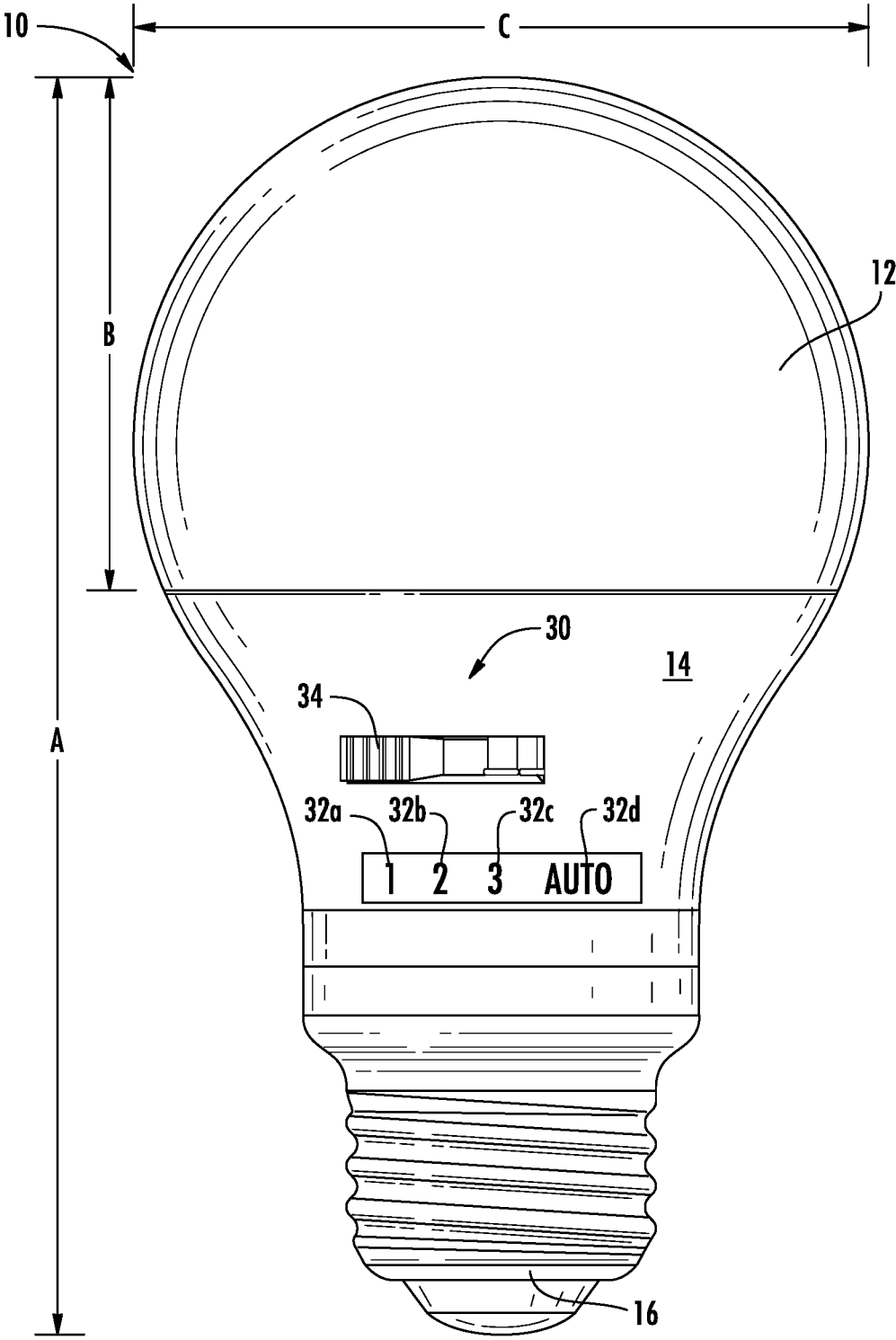

FIG. 1A

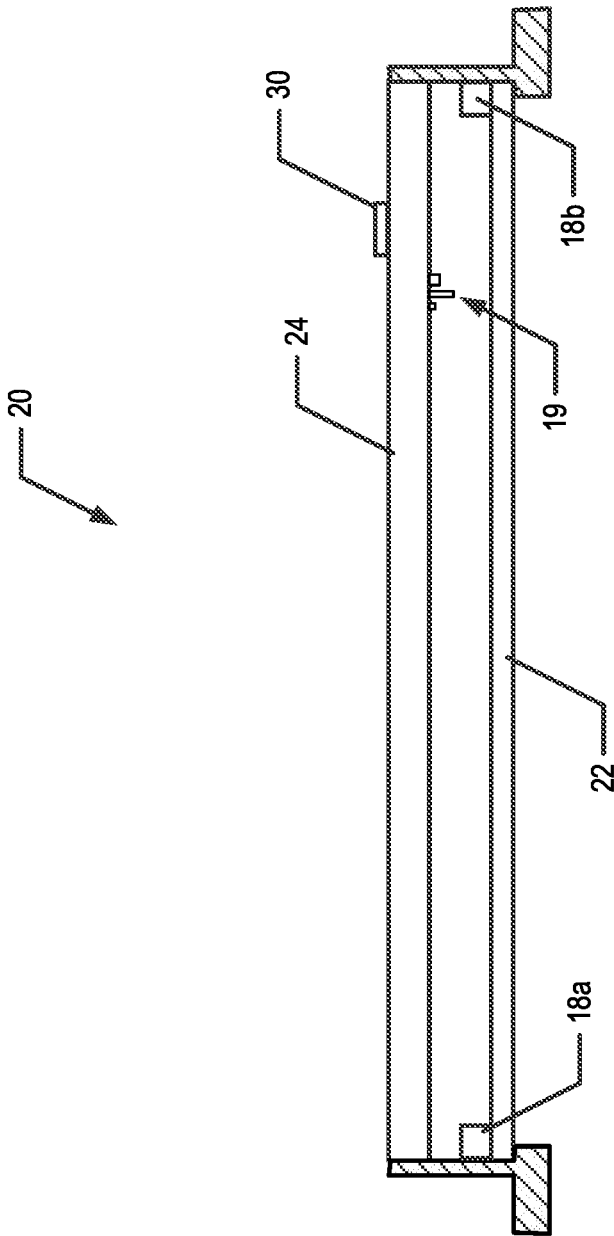

FIG. 2

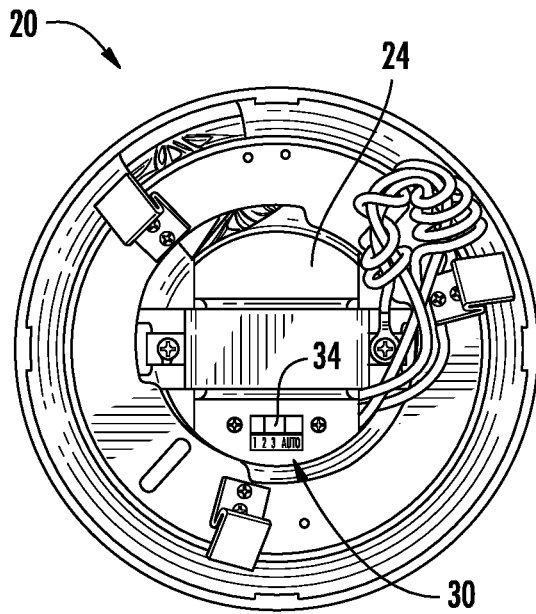

FIG. 2A

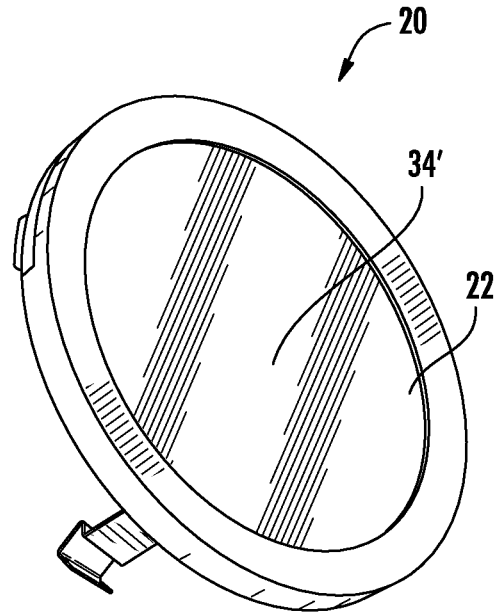

FIG. 2B

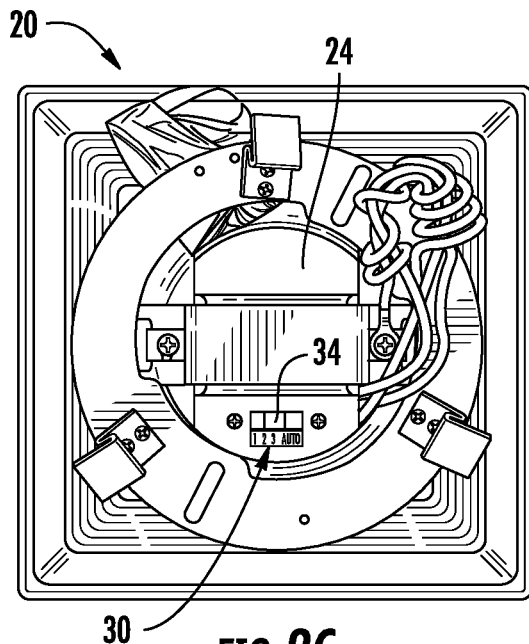

FIG. 2C

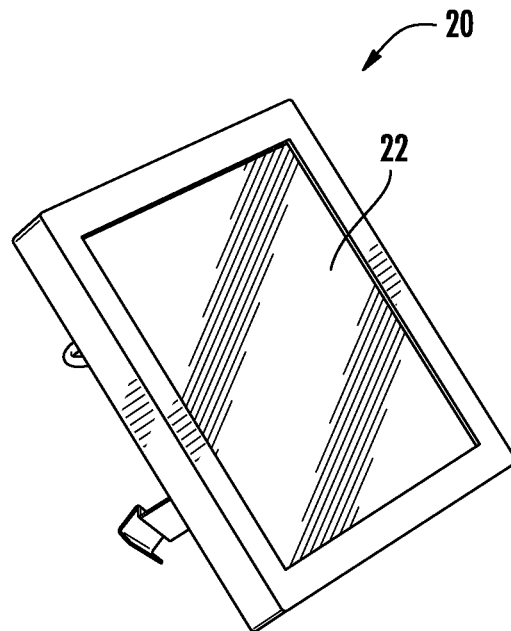

FIG. 2D

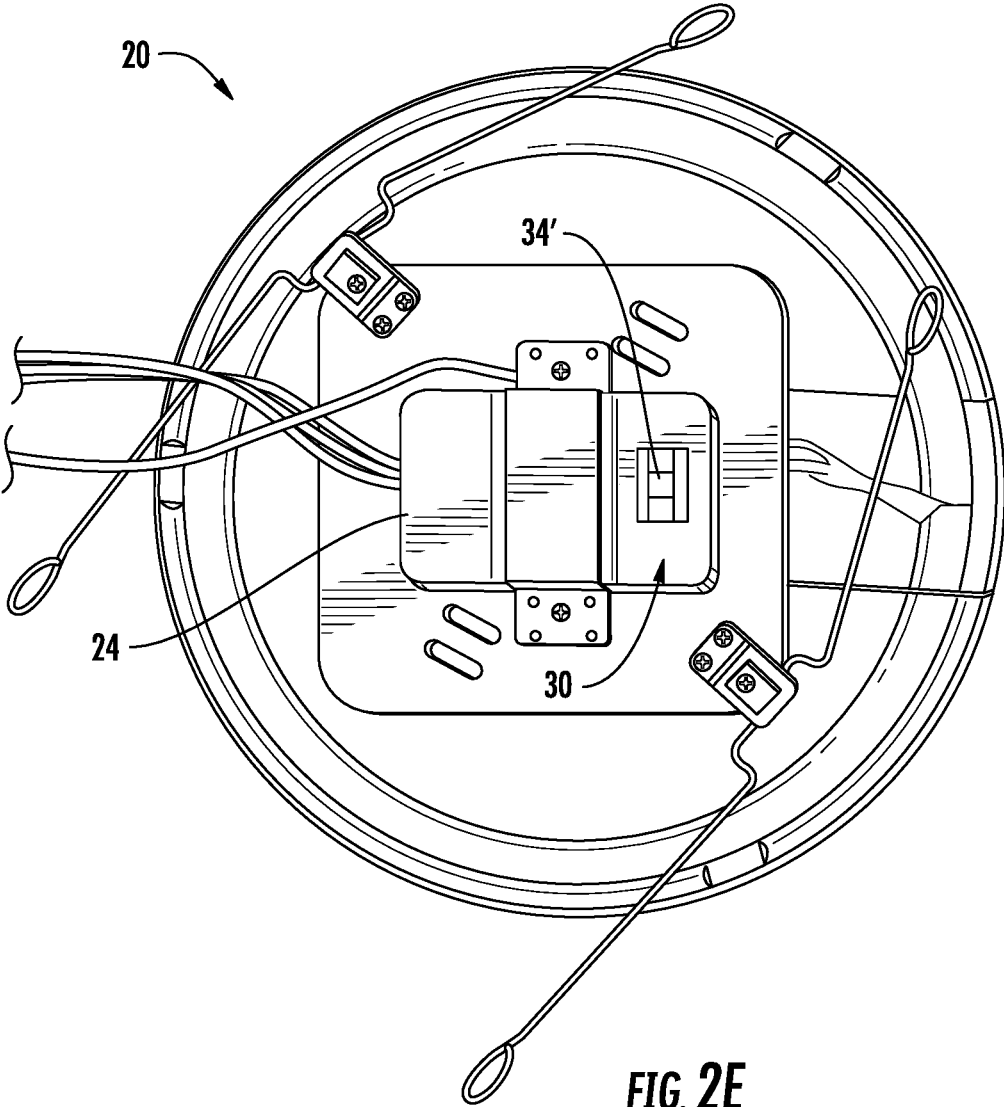
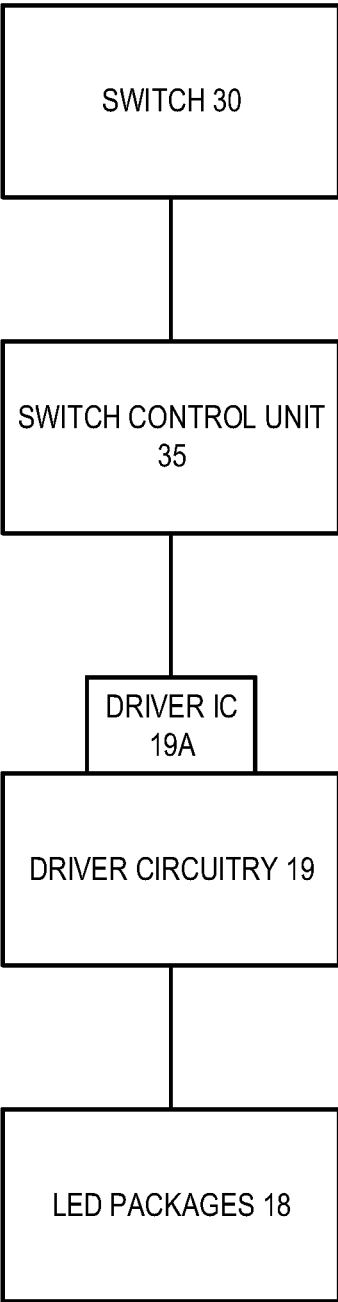

FIG. 2E



**FIG. 3**

FIG. 4

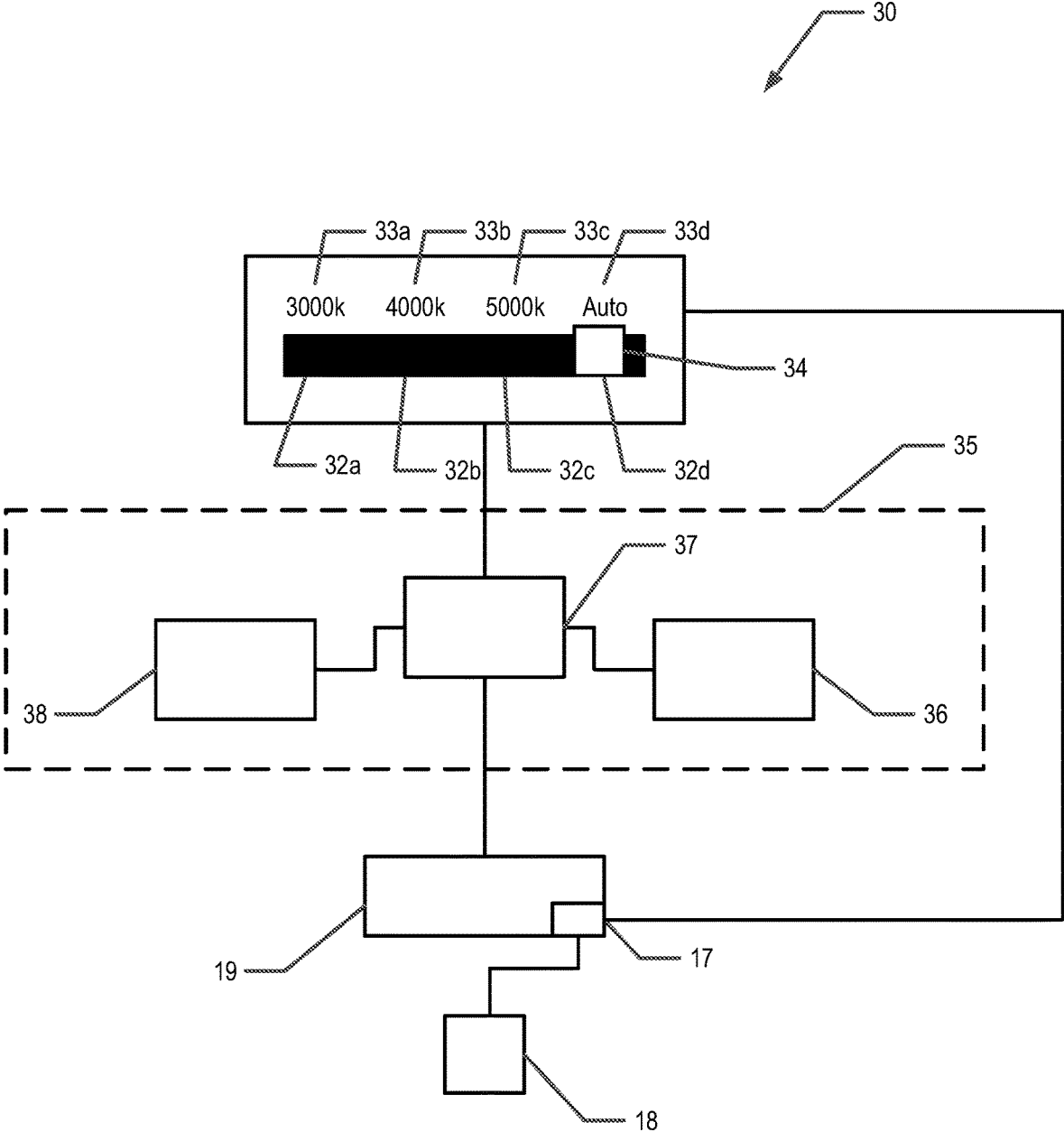

FIG. 4A

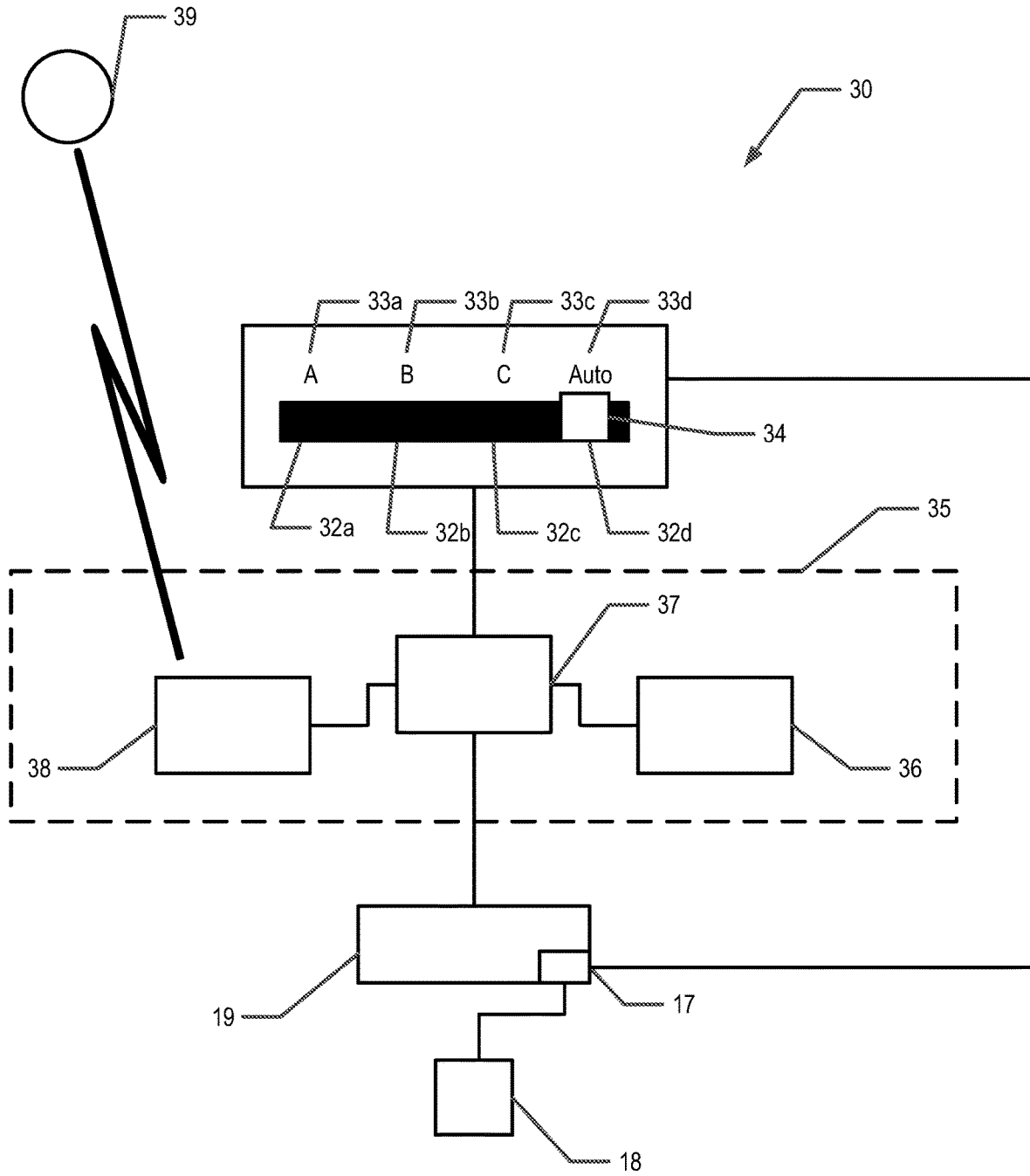

FIG. 5

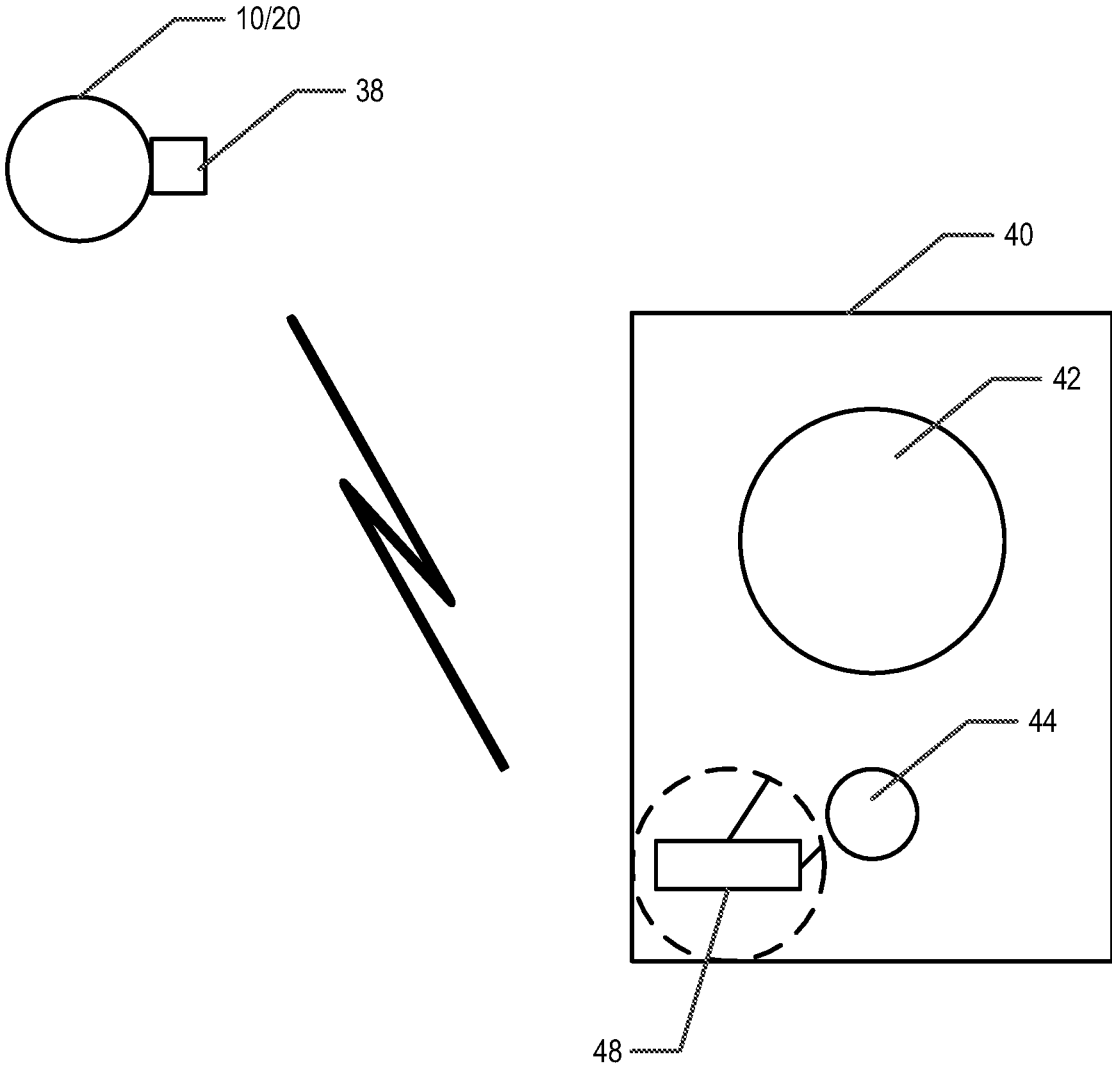

FIG. 6

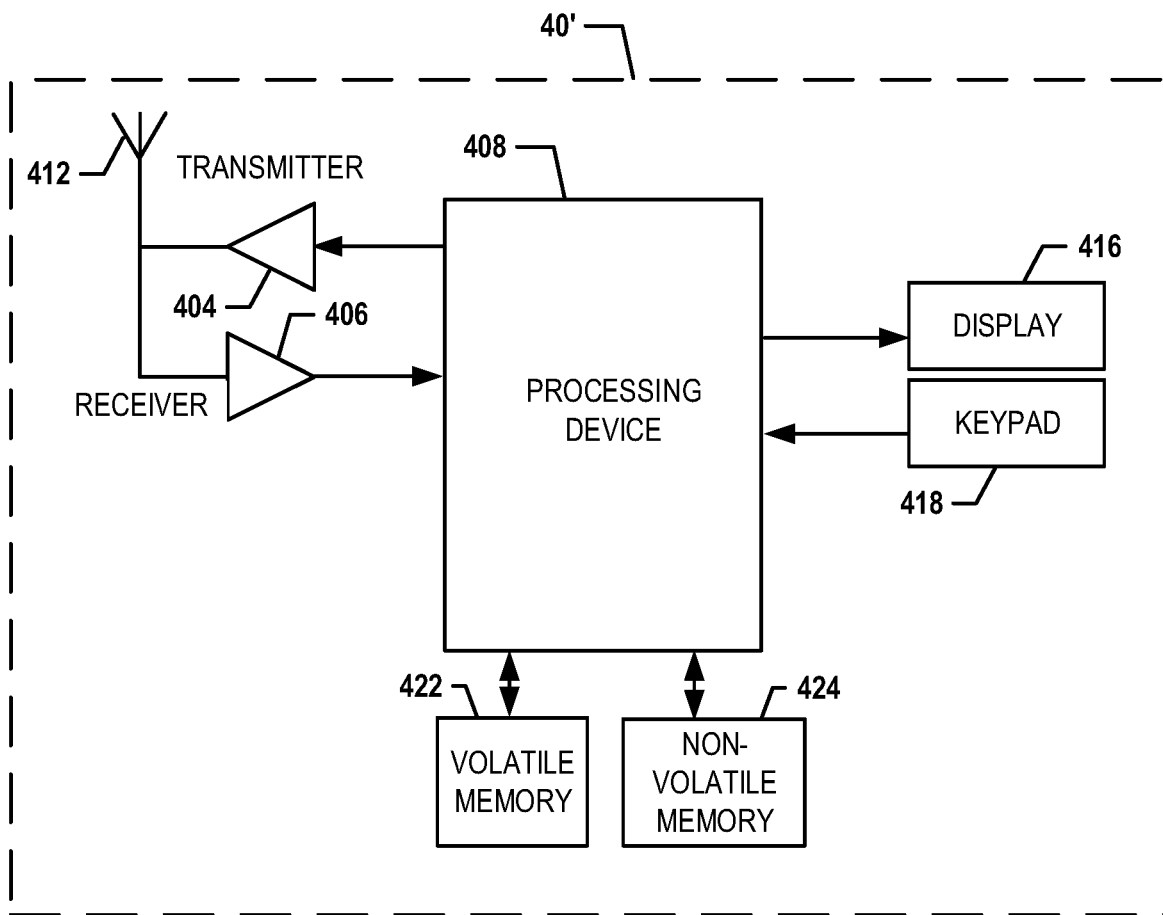

FIG. 7

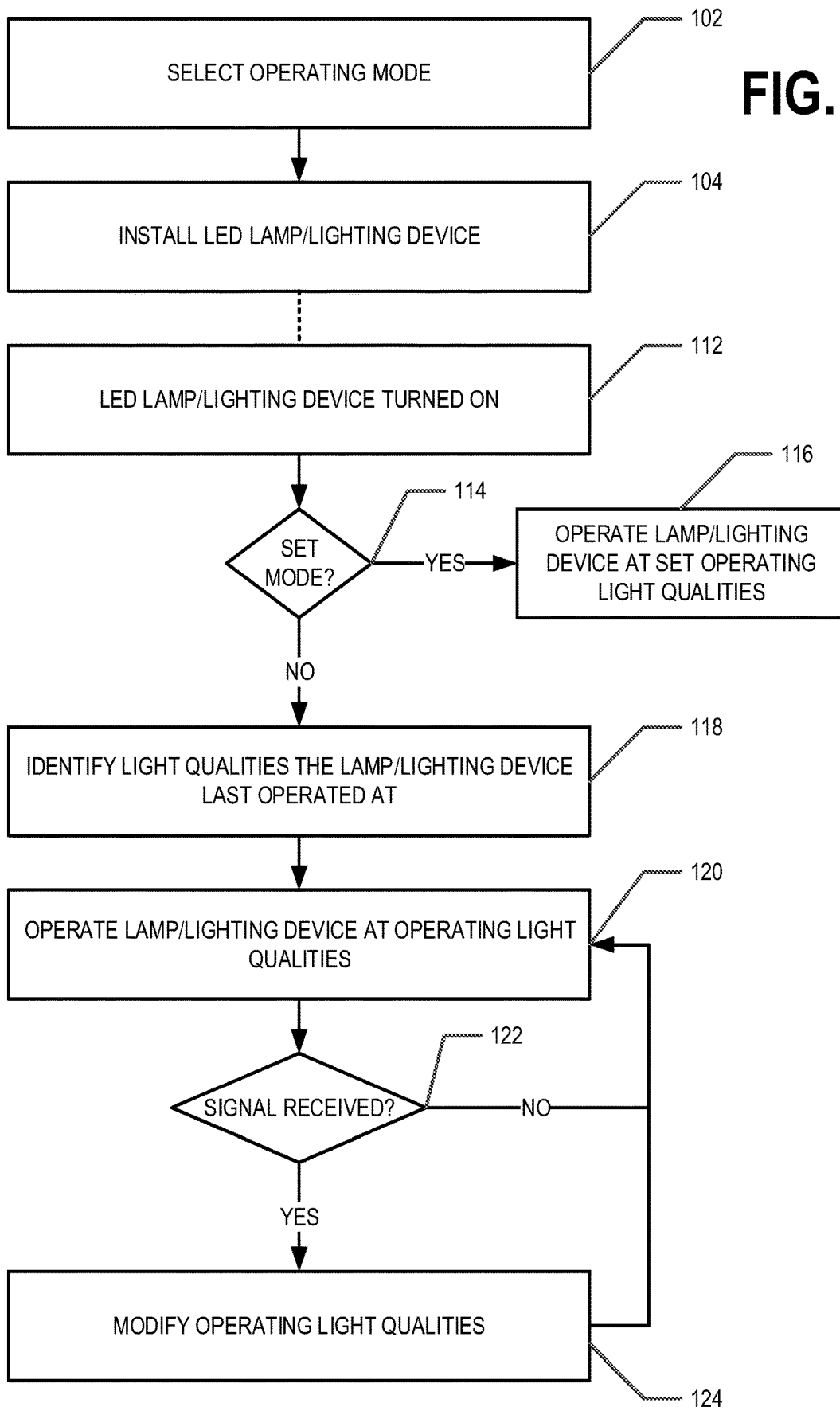

FIG. 8

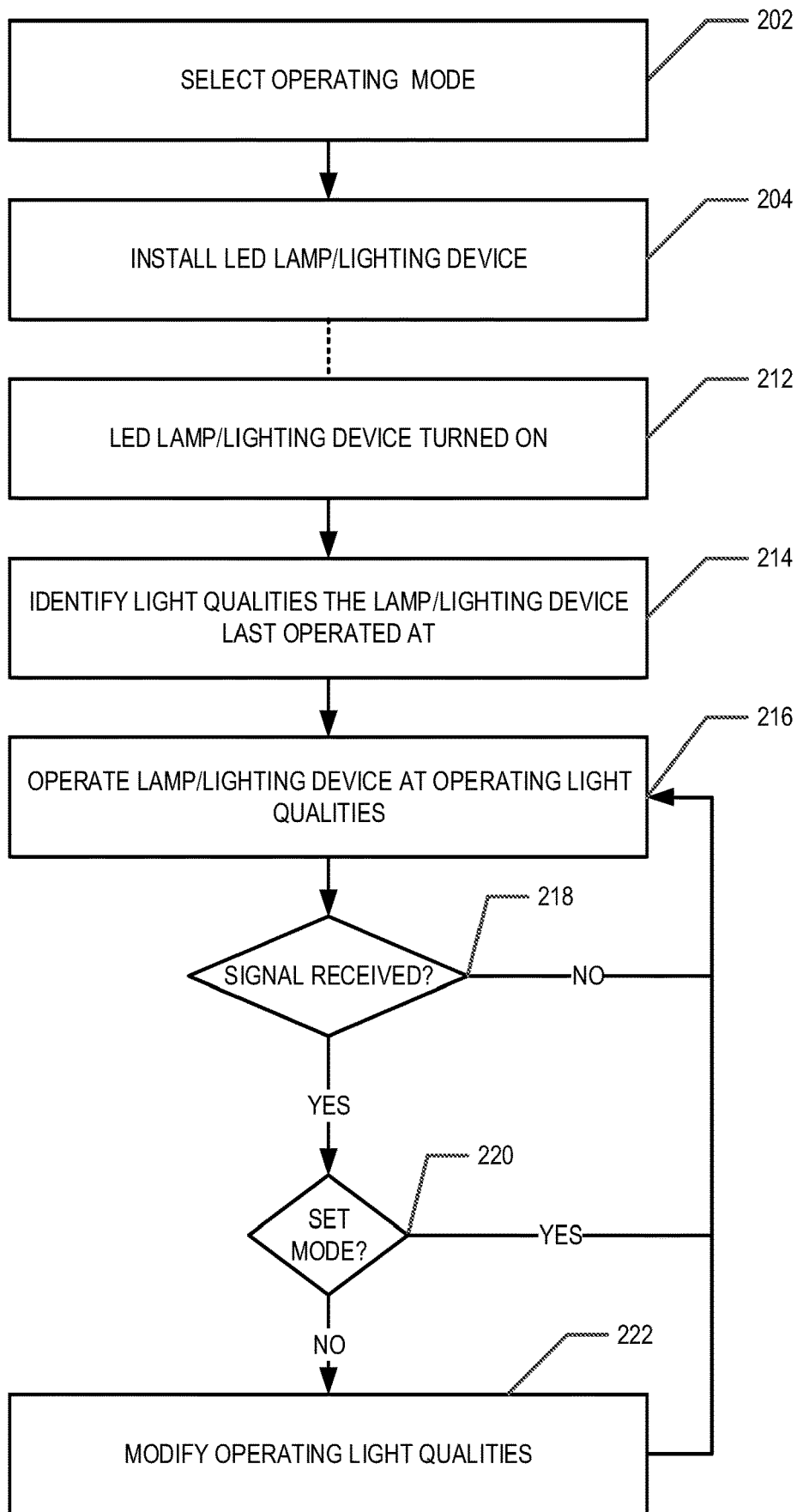
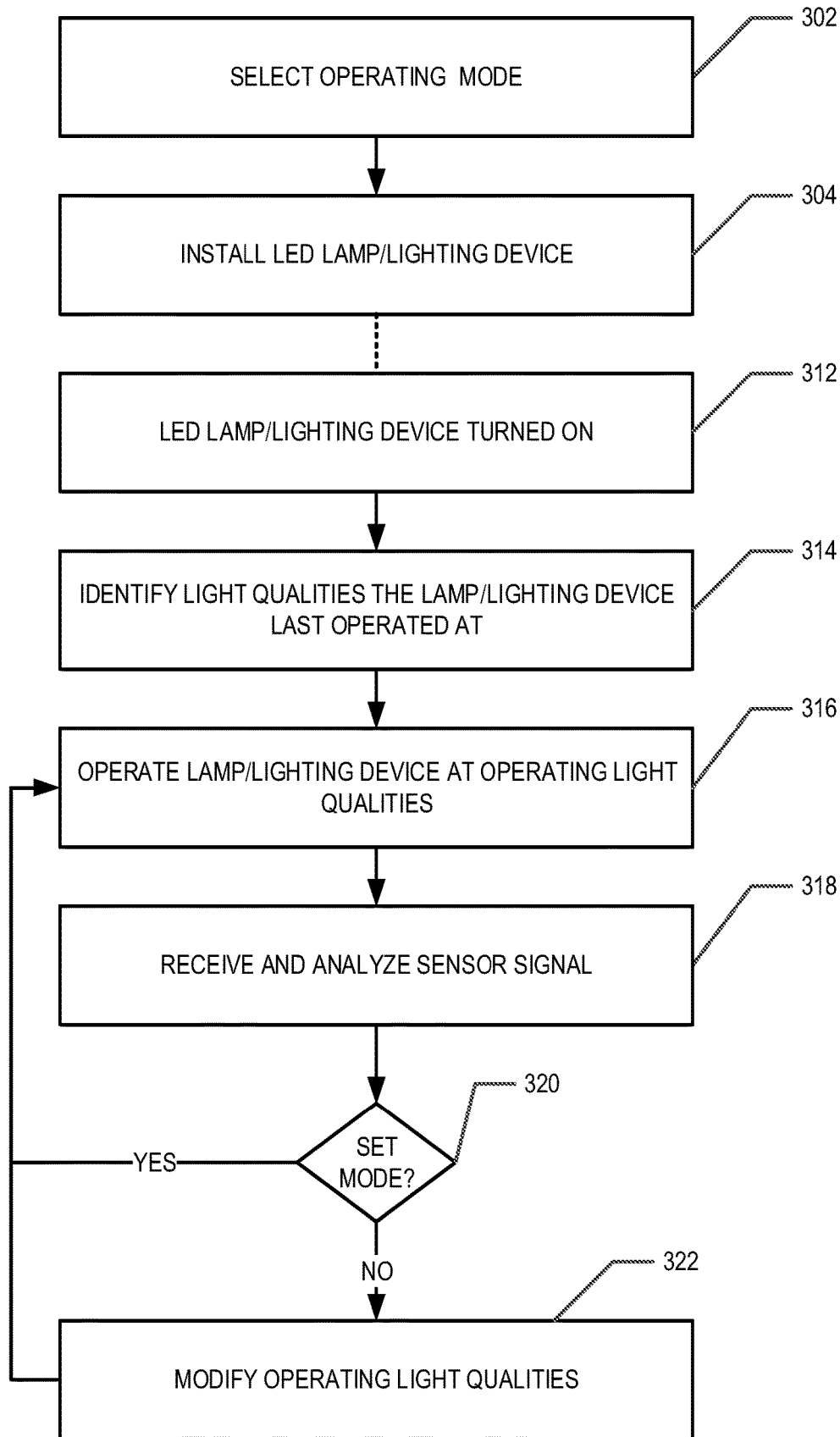

FIG. 9



1

**LIGHT EMITTING DIODE (LED) LIGHTING  
DEVICE OR LAMP WITH CONFIGURABLE  
LIGHT QUALITIES**

**CROSS-REFERENCE TO RELATED  
APPLICATIONS**

This application is a continuation-in-part of U.S. application Ser. No. 15/705,808 filed Sep. 15, 2017, which is a continuation of U.S. application Ser. No. 15/274,575, filed Sep. 23, 2016, the contents of which are incorporated by reference herein in their entireties.

**BACKGROUND**

Incandescent bulbs are slowly being phased out in favor of more efficient lighting sources. This has led to an increased use of compact fluorescent bulbs which are more efficient than incandescent bulbs, but which tend to contain dangerous gasses, such as mercury. Compact fluorescent bulbs are also affected by ambient temperature and fail reach their peak brightness in colder conditions. Additionally, many people find the color temperature of light emitted by compact fluorescents to not be aesthetically pleasing for many applications, such as household lighting in kitchens, bathrooms, and living rooms; some commercial applications; and the like. Due to the nature of compact fluorescent bulbs, the bulbs always have a frosted appearance, which also tends to reduce the aesthetic appeal of compact fluorescent bulbs. The use of halogen bulbs has also increased; however due to the high temperatures at which halogen bulbs operate they are not highly efficient and may be a fire or burn hazard.

Recent advances in manufacturing light emitting diodes (LEDs) combined with the efficiency and long lifetime of LEDs have led to an increase in the availability and affordability of LED lamps and other LED lighting devices. LED lamps and lighting devices offer advantages over compact fluorescent bulbs including longer lifetime and the absence of dangerous gasses. Also, LED lamps and lighting devices may be configured to emit light at a wide variety of color temperatures.

Therefore, there is a need in the art for LED lighting devices that allow users to take advantage of the wide variety of color temperatures at which LEDs may emit light.

**BRIEF SUMMARY**

Embodiments of the present invention provide an LED lighting device or LED lamp for which one or more aspects of the light emitted from the LED lighting device or LED lamp (e.g., color temperature, brightness, color rendering index (CRI), and/or the like) is configurable and/or adjustable. For example, the LED lamp or LED lighting device may allow a user to select an operating mode (e.g., a programmable custom mode, a set mode, or a configurable mode). One or more qualities of the light (e.g., color temperature, brightness, CRI, and/or the like) emitted by the LED lamp or LED lighting device may then be controlled based on the user-selected operating mode. For example, a particular LED lamp or LED lighting device may be configured to emit light at a user-selected color temperature. For example, a user may set one or more light aspects or qualities (e.g., brightness, color temperature, CRI, and/or the like) at which the LED lighting device or LED lamp emits light at the time the LED lighting device or LED lamp is installed. Alternatively, the user may select to place the LED

2

lighting device or LED lamp in a configurable operating mode. In the configurable operating mode, a user may use a remote switch (e.g., a wall switch, remote control, mobile computing device, building control system, and/or the like) to change the one or more operating light aspects or qualities at which the LED lighting device or LED lamp emits light during the operation of the LED lighting device or LED lamp. For example, the user may use a remote switch to toggle between preset operating light aspects or qualities.

According to one aspect of the present invention, an LED lighting device or LED lamp is provided. In example embodiments, the LED lighting device or LED lamp comprises one or more LED packages; driver circuitry configured to provide a controllable electrical current to at least one of the one or more LED packages during operation of the LED lighting device or LED lamp; a switch comprising at least two selectable options. At least one selectable option corresponds to a set operating mode and one selectable option corresponds to a configurable operating mode. The LED lighting device or LED lamp further comprises a user-selection switch for receiving user-selection of operating light qualities when the switch is in a position to select the configurable operating mode.

According to another aspect of the present invention, an LED lighting device or LED lamp is provided. In example embodiments, the LED lighting device or LED lamp comprises one or more LED packages; driver circuitry configured to provide a controllable electrical current to at least one of the one or more LED packages during operation of the LED lighting device or LED lamp; and a switch comprising at least two selectable options. At least one selectable option corresponds to a set operating mode and one selectable option corresponds to a configurable operating mode. When the LED lighting device or LED lamp is on and when the switch is in a position to select a selectable option corresponding to a set operating mode, the driver circuitry operates at least one of the one or more LED packages to emit light having set operating light qualities corresponding to the set operating mode. When the LED lighting device or LED lamp is on and when the switch is in a position to select the selectable option corresponding to the configurable operating mode, the driver circuitry operates at least one of the one or more LED packages to emit light having operating light qualities corresponding to a most recently received signal indicating a user-selection, the user-selection provided through user interaction with a wall or junction box mounted remote switch.

According to another aspect of the present invention, an LED lighting device or LED lamp is provided. In example embodiments, the LED lighting device or LED lamp comprises one or more LED packages; driver circuitry configured to provide a controllable electrical current to at least one of the one or more LED packages during operation of the LED lighting device or LED lamp; and a switch comprising at least two selectable options. At least one selectable option corresponds to a set operating mode and one selectable option corresponds to a configurable operating mode. When the LED lighting device or LED lamp is on and when the switch is in a position to select a selectable option corresponding to a set operating mode, the driver circuitry operates at least one of the one or more LED packages to emit light having set operating light qualities corresponding to the set operating mode. When the LED lighting device or LED lamp is on and when the switch is in a position to select the selectable option corresponding to the configurable operating mode, the driver circuitry operates at least one of the one or more LED packages to emit light having oper-

ating light qualities corresponding to a most recently received signal indicating a user-selection, the user-selection provided through user interaction with a portable remote switch.

According to yet another aspect of the present invention, an LED lighting device or LED lamp is provided. In an example embodiment, the LED lighting device or LED lamp comprises one or more LED packages; and a switch control unit configured to operate the one or more LED packages. The switch control unit is in communication with a sensor located in a space, the LED lighting device or LED lamp also being located in the space. The switch control unit is configured to (i) receive a sensor signal from the sensor, (ii) process the sensor signal, (iii) determine an adjustment to the operating light qualities of the LED lighting device or LED lamp based on the processing of the sensor signal and one or more goal light qualities corresponding to the space, and (iv) adjust the operation of the one or more LED packages in accordance with the adjustment.

According to still another aspect of the present invention, an LED lighting device or LED lamp is provided. In an example embodiment, the LED lighting device or LED lamp comprises one or more LED packages; a switch comprising at least two selectable positions, at least one selectable position corresponding to a set operating mode and one selectable position corresponding to a configurable operating mode; and a switch control unit configured to operate the one or more LED packages. The switch control unit is in communication with a sensor located in the space. The switch control unit is configured to (i) receive a sensor signal from the sensor, (ii) process the sensor signal, (iii) determine an adjustment to the operating light qualities of the LED lighting device or LED lamp based on the processing of the sensor signal and one or more goal light qualities corresponding to the space, and (iv) adjust the operation of the one or more LED packages in accordance with the adjustment. When the switch is in the selectable position corresponding to the set operating mode, (a) the one or more LED packages are operated in accordance with predefined goal light qualities corresponding to the set operating mode and (b) responsive to receiving an indication of user input for selecting user-selected goal light qualities, the one or more LED packages continue to be operated in accordance with the predefined goal light qualities corresponding to the set operating mode. When the switch is in the selectable position corresponding to the configurable operating mode, responsive to receiving an indication of user input for selecting user-selected goal light qualities, operation of the one or more LED packages is modified in accordance with the user-selected goal light qualities.

According to another aspect of the present invention, an LED lighting device or LED lamp is provided. In an example embodiment, the LED lighting device or LED lamp comprises one or more LED packages; a switch comprising at least two selectable positions, at least one selectable position corresponding to a non-adjustment mode and at least one selectable position corresponding to a sensor adjustment mode; and a switch control unit configured to operate the one or more LED packages. The switch control unit is in communication with a sensor located in a space, the LED lighting device or LED lamp also being located in the space. The switch control unit is configured to (i) receive a sensor signal from the sensor, (ii) process the sensor signal, (iii) determine an adjustment to the operating light qualities of the LED lighting device or LED lamp based on the processing of the sensor signal and one or more goal light qualities corresponding to the space, and (iv) adjust the

operation of the one or more LED packages in accordance with the adjustment. When the switch is in the selectable position corresponding to the non-adjustment mode, (a) the one or more LED packages are operated in accordance with predefined operating light qualities and (b) responsive to receiving and processing the sensor signal, the one or more LED packages continue to be operated in accordance with the predefined operating light qualities. When the switch is in the selectable position corresponding to the sensor adjustment mode, responsive to receiving and processing the sensor signal, operation of the one or more LED packages is adjusted in accordance with the adjustment such that at least one light quality in the space is in accordance with the one or more goal light qualities.

#### BRIEF DESCRIPTION OF THE SEVERAL VIEWS OF THE DRAWING(S)

Having thus described the invention in general terms, reference will now be made to the accompanying drawings, which are not necessarily drawn to scale, and wherein:

FIG. 1 is a partial cutaway perspective view of an example LED lamp in accordance with an example embodiment of the present invention;

FIG. 1A is a perspective view of an example LED lamp in accordance with an example embodiment of the present invention;

FIG. 2 is a cross section of an example LED lighting device in accordance with an example embodiment of the present invention;

FIG. 2A is a back view of an example LED lighting device in accordance with an example embodiment of the present invention;

FIG. 2B is a front view of the example LED lighting device shown in FIG. 2A;

FIG. 2C is a back view of another example LED lighting device in accordance with an example embodiment of the present invention;

FIG. 2D is a front view of the example LED lighting device shown in FIG. 2C;

FIG. 2E is a back view of another example LED lighting device in accordance with an example embodiment of the present invention;

FIG. 3 is a block wiring diagram of an LED lamp or LED lighting device in accordance with example embodiments of the present invention;

FIG. 4 is a block diagram of at least some of the electrical components of an LED lamp or LED lighting device in accordance with example embodiments of the present invention;

FIG. 4A is another block diagram of at least some of the electrical components of an LED lamp or LED lighting device in accordance with example embodiments of the present invention;

FIG. 5 is a block diagram of a remote switch in communication with an LED lamp or LED lighting device in accordance with example embodiments of the present invention;

FIG. 6 is a block diagram of a computing entity that may be used as a remote switch in communication with an LED lamp or LED lighting device in accordance with example embodiments of the present invention;

FIG. 7 provides a flowchart illustrating processes and procedures of installing and operating an LED lamp or LED lighting device in accordance with example embodiments of the present invention;

5

FIG. 8 provides a flowchart illustrating processes and procedures of installing and operating an LED lamp or LED lighting device in accordance with other example embodiments of the present invention; and

FIG. 9 provides a flowchart illustrating processes and procedures of installing and operating an LED lamp or LED lighting device in accordance with other example embodiments of the present invention.

#### DETAILED DESCRIPTION OF VARIOUS EMBODIMENTS

The present invention now will be described more fully hereinafter with reference to the accompanying drawings, in which some, but not all embodiments of the invention are shown. Indeed, the invention may be embodied in many different forms and should not be construed as limited to the embodiments set forth herein; rather, these embodiments are provided so that this disclosure will satisfy applicable legal requirements. Like numbers refer to like elements throughout.

Example embodiments of the present invention provide an LED lamp or LED lighting device having two or more user selectable modes. Switching between modes may adjust one or more aspects or qualities of the light provided by the LED lamp or LED lighting device when the LED lamp or LED lighting device is operating. For example, switching between modes may adjust the quality of the light provided by the LED lamp or LED lighting device when the LED lamp or LED lighting device is operating. For example, switching between modes may adjust the brightness, color rendering index (CRI), color temperature, and/or the like of the light emitted by the LED lamp or LED lighting device when the LED lamp or LED lighting device is operating.

Example embodiments of the present invention described herein generally relate to an LED lamp or LED lighting device wherein the operating light aspects or qualities (e.g., brightness, color temperature, CRI, and/or the like of the light emitted by the LED lamp or LED lighting device when the LED lamp or LED lighting device is being operated and/or is turned on), is selectively configurable. For example, example embodiments of the present invention described herein generally relate to an LED lamp or LED lighting device wherein the operating color temperature (e.g., the color temperature of the light emitted by the LED lamp or LED lighting device when the LED lamp or LED lighting device is being operated and/or is turned on), is selectively configurable. However, it should be understood that principles of the present invention may be used to provide an LED lamp or LED lighting device for which one or more aspects or qualities of the light provided during operation of the LED lamp or LED lighting device may be modified through selection of a particular mode. Examples of the aspects that may be modified through mode selection may include, but are not limited to, brightness, CRI, color temperature, and/or combinations thereof.

For example, a user may select a desired operating light aspects or qualities (e.g., color temperature, brightness, CRI, and/or the like, and/or a combination thereof) for the LED lamp or LED lighting device before the LED lamp or LED lighting device is installed. Alternatively, the user may select to operate the LED lamp or LED lighting device in a configurable operating mode following installation. For example, the LED lamp or LED lighting device may be operated in a configurable mode that allows a user to change one or more of the operating light aspects or qualities during operation of the LED lamp or LED lighting device using a

6

remote switch. In example embodiments, a remote switch may be a wall mounted switch mounted in the same room as the LED lamp or LED lighting device and/or within a short range communication technology range of the LED lamp or LED lighting device. In another example, the remote switch may be a handheld device (e.g., a remote control), computing entity, and/or the like, that is within the same room as the LED lamp or LED lighting device, within a short range communication technology range of the LED lamp or LED lighting device, and/or in communication with the LED lamp or LED lighting device through a wired and/or wireless network.

As noted above, LEDs may be manufactured that emit light at a variety of color temperatures. Moreover, LEDs may be configured to emit light at a variety of brightness, CRI, and/or having other configurable light aspects or qualities. Embodiments of the present invention allow a user to take advantage of the variety of light aspects or qualities at which LEDs may emit light by allowing the user to operate an LED lamp or LED lighting device at a selectable mode such that the user may select and/or modify aspects or qualities of the emitted light. For example, embodiments of the present invention allow a user to take advantage of the variety of color temperatures at which LEDs may emit light by allowing the user to operate an LED lamp or LED lighting device at a selectable configurable operating color temperature. For example, the user may be able to change the operating color temperature of the LED lamp or LED lighting device as the user desires during the operation of the LED lamp or LED lighting device. The user may also choose to select a programmable operating color temperature for the LED lamp or LED lighting device. For example, the LED lighting device or LED lamp may be programmed to a set operating color temperature mode in which the operating color temperature cannot be changed during operation of the LED lamp or LED lighting device. Thus, embodiments of the present invention allow a user to take advantage of the wide range of color temperatures at which LEDs may produce light.

For example, given the wide array of color temperatures and other light aspects or qualities (e.g., brightness, CRI, etc.) available in LED lamps and LED lighting devices, retailers need to stock a variety of different color temperature, brightness, and/or other light aspect or quality options for each style of LED lamp and/or LED lighting device to provide consumers with the options the consumer's desire. Moreover, it is common in multiple purpose rooms (e.g., family rooms, etc.) that different lighting options may be desired. For example, a light having an operating color temperature of 5000k may be desired if a user is sitting on the couch reading, but the user may prefer a light having an operating color temperature of 3000K when watching television. Traditionally this would require the user to have two lighting options available in the same room. However, example embodiments of the present invention allow the user to have a light source of operating temperature of 3000K and a light source of operating temperature of 5000K while only requiring one lighting device. Similarly, with example embodiments of the present invention, retailers need only to stock LED lamps and/or LED lighting devices based on the style of the lamp and/or lighting device as the operating color temperature and/or other light aspects or qualities of the lamp and/or lighting device are selectable.

In example embodiments, the LED lamp **10** or LED lighting device **20** allows a user to select an operating mode (e.g., a programmable custom mode, a set mode, or a configurable mode). One or more qualities of the light (e.g.,

color temperature, brightness, CRI, and/or the like) emitted by the LED lamp **10** and/or LED lighting device **20** may then be controlled based on the user-selected operating mode. One or more qualities of the light emitted by the LED lamp **10** and/or LED lighting device **20** may be modified through mode switching (e.g., using switch **30**) and/or configured using a remote switch **40** when the user-selected mode is a configurable mode.

In an example embodiment, the LED lamp **10** or LED lighting device **20** allows a user to select between one or more non-adjustment modes in which the user may select the operating qualities of the light emitted by the LED lamp **10** or LED lighting device **20** and one or more sensor adjustment modes in which the user may select goal light qualities for a space that the LED lamp **10** or LED lighting device **20** is located in. In various embodiments, the non-adjustment mode(s) and/or sensor adjustment mode(s) may be set operating modes and/or configurable operating modes. In an example embodiment, the LED lamp **10** or LED lighting device **20** may be in communication with one or more sensors (e.g., light sensor, photocell, motion sensor), and, when the LED lamp **10** or LED lighting device **20** is in a sensor adjustment mode, the operating qualities of the LED lamp **10** or LED lighting device **20** may be adjusted and/or modified based on sensor signals received from the one or more sensors.

#### Example LED Lamp

FIG. 1 provides a partial cutaway perspective view of an example LED lamp **10** in accordance with an example embodiment of the present invention. Additionally, FIG. 1A provides a perspective view of an example LED lamp **10** in accordance with an example embodiment of the present invention. In example embodiments, the LED lamp **10** may comprise a lamp envelope **12**, a lamp housing **14**, a lamp base **16**, two or more LED packages **18**, driver circuitry **19**, a switch control unit **35**, a switch **30**, and/or the like. In example embodiments, the lamp envelope **12** may be transparent, translucent, and/or semi-translucent and configured to enclose the optical components (e.g., the two or more LED packages **18**, optics **13**, and/or the like). In example embodiments, the lamp housing **14** may be configured to house the driver circuitry **19**, switch control unit **35** (shown in FIG. 4), a heat sink, heat dissipation elements (e.g., fins, radiators, and/or the like), and/or other elements of the LED lamp **10**. For example, the switch **30** may be located on an exterior surface of the lamp housing **14**. The lamp base **16** may be configured for physically securing the LED lamp **10** into a socket of a lighting device and electrically connecting the driver circuitry **19**, switch control unit **35**, and/or other electrical component of the LED lamp **10** to the socket such that the LED lamp **10** may be electrically powered through the socket. In example embodiments, the lamp base **16** and/or the LED lamp **10** may be the size of a traditional/standard incandescent lamp. For example, the lamp base **16** and/or the LED lamp **10** may be sized according to an A15, A19, A21, A22, B8, B10, C7, C9, C11, C15, F10, F15, F20 and/or traditional/standard lamp size. For example, the lamp base **16** of the LED lamp **10** shown in FIG. 1A is in accordance with a traditional/standard A19 lamp size. For example, in one embodiment, the length of the LED lamp **10**, a, is 111 mm, the length of the lamp envelope **12**, b, is 43 mm, and the width of the lamp envelope **12**, c, is 59.9 mm or approximately 60 mm. In various embodiments, the size of the LED lamp **10** may vary based as appropriate for the application.

FIG. 3 provides a block wiring diagram of an example LED lamp **10** or LED lighting device **20**. The electrical

components of the LED lamp **10** may comprise a switch **30** in electrical communication with a switch control unit **35**. The switch control unit **35** may be in electrical communication with the driver circuitry **19**. In an example embodiment, the switch control unit **35** may be in electrical communication with a driver integrated circuit (IC) **19a** configured to control, condition, configure and/or the like the electrical current provided to one or more LED packages **18**. The driver circuitry **19** may then provide the configurable electrical current to the one or more LED packages **18**, causing the LED lighting device to be operated according to the mode selected through the switch **30**.

#### Example LED Lighting Device

FIG. 2 provides a cross section view of an example LED lighting device **20**. The illustrated lighting device **20** is an edge-lit LED flat panel lighting fixture configured to be mounted on a ceiling or wall, suspended as a pendant, and/or the like. In various embodiments, the LED lighting device **20** may be a lighting fixture, a luminaire, a floor lamp, a desk lamp, and/or the like. FIGS. 2A, 2C, and 2E provide a back views of example LED lighting devices **20** that are configured to be flush mounted to a mounting surface (e.g., wall, ceiling, and/or the like). In various embodiments, an example LED lighting device **20** may be flush mounted to a mounting surface, within a recessed lighting receptacle, and/or the like. For example, the LED lighting device **20** may be floor lamp, table lamp, wall or ceiling mounted lighting fixture, a troffer lighting fixture (e.g., a 2'x4' LED troffer or other troffer), a tube lighting fixture, a flat panel lighting fixture (e.g., a square, round, or other shaped flat panel fixture), and/or other lighting fixture for use in residential or business settings. FIGS. 2B and 2D provide front views of the example lighting devices **20** shown in FIGS. 2A and 2C, respectively.

In example embodiments, the LED lighting device **20** comprises a device housing **24**, a device lens **22**, one or more LED packages **18**, driver circuitry **19**, a switch control unit **35**, a switch **30**, and/or the like. For example, the device housing **24** may be configured to house the driver circuitry **19**; switch control unit **35**; one or more LED packages **18**; one or more optical elements; one or more heat sink elements; one or more heat dissipation elements; one or more mounting elements configured for mounting the LED lighting device **20** to a ceiling, wall, as a pendant, as a recessed lighting device, and/or the like; one or more stand elements configured for supporting and providing an aesthetic appearance to a luminaire; and/or the like. For example, the switch **30** may be mounted on an exterior surface of the LED lighting device **20**. For example, the switch **30** may be mounted on a back, bottom, or otherwise generally hidden surface of the device housing **24** such that the switch **30** is not generally viewable by a user when the LED lighting device **20** is in operation. In some embodiments, the switch **30** may be accessible to the user when the LED lighting device **20** is installed. In such embodiments, the switch **30** may still be generally hidden and/or not located where the switch **30** is easily viewable (e.g., the switch **30** is generally not located on the front of the LED lighting device **20**).

In example embodiments the device lens **22** may be transparent, translucent, and/or at least semi-translucent and configured to enclose the optical and/or electrical components of the LED lighting device **20** within the device housing **24**. In example embodiments, the electrical components of the LED lighting device **20** (e.g., the driver circuitry **19**, switch control unit **35**, and/or the like) may be configured to be directly wired to line voltage (e.g., through

a junction box) or may be configured to be connected to line voltage through a power cord comprising a two- or three-prong polarized plug.

FIG. 3 provides a block wiring diagram of an example LED lamp **10** or LED lighting device **20**. The electrical components of the LED lighting device **20** may comprise a switch **30** in electrical communication with a switch control unit **35**. The switch control unit **35** may be in electrical communication with the driver circuitry **19**. In an example embodiment, the switch control unit **35** may be in electrical communication with a driver integrated circuit (IC) **19a** configured to control, condition, configure and/or the like the electrical current provided to one or more LED packages **18**. The driver circuitry **19** may then provide the configurable electrical current to the one or more LED packages **18**, causing the LED lighting device to be operated.

#### Exemplary LED Packages

In example embodiments, the LED lamp **10** or LED lighting device **20** may comprise one or more LED packages **18**. In example embodiments, an LED package **18** comprises one or more LED chips, electrical contacts, and optionally phosphor (e.g., to cause the LED package to emit white light). The LED package **18** may further comprise encapsulant to protect the one or more LED chips, wire bonds, and the phosphor. In an example embodiment, the LED packages **18** may comprise one or more alternate current (AC) driven LEDs. In some embodiments, the LED package **18** may further comprise one or more optical elements. In example embodiments, the one or more LED packages **18** may comprise two or more LED packages **18**. In example embodiments, the two or more LED packages may comprise at least one first LED package **18a** and at least one second LED package **18b**. The first LED package **18a** may be configured to emit light at a first color temperature and the second LED package **18b** may be configured to emit light at a second color temperature. The second color temperature may be different from the first color temperature. For example, the first color temperature may be 3000K or 2700K and the second color temperature may be 5000K. In example embodiments, the two or more LED packages **18** may further comprise a third and/or fourth LED package configured to emit light at a third and/or fourth color temperature, respectively, wherein the third and/or fourth color temperature are different from the first and second color temperatures. For example, in various embodiments, one or more of the LED packages **18** may be configured to emit light of at least one of 2700K, 3000K, 3500K, 4000K, 5000K, 5700K, 6000K, 7000K, 7500K and/or other color temperatures, as appropriate for the application. For example, as shown in FIG. 4A, the LED lamp **10** or LED lighting device may be configured to selectively provide light of color temperature A, B, or C, wherein A, B, and C may be any preset color temperature provided each is different relative to one another

In example embodiments, the two or more LED packages **18** may be in electrical communication with driver circuitry **19** such that the two or more LED packages **18** may be operated by the driver circuitry **19**. For example, the driver circuitry **19** may provide a controlled electrical current to at least one of the LED packages **18**. For example, the driver circuitry **19** may be configured to only operate first LED packages **18a** to cause the LED lamp **10** or LED lighting device **20** to emit light of the first color temperature. In another example, the driver circuitry **19** may be configured to only operate second LED packages **18b** to cause the LED lamp **10** or LED lighting device **20** to emit light of the second color temperature. In another example, the driver

circuitry **19** may be configured to operate one or more (e.g., half) of the first LED packages **18a** and one or more (e.g., half) of the second LED packages **18b** to cause the LED lamp **10** or LED lighting device **20** to emit light of a third color temperature. In example embodiments, the first color temperature, second color temperature, and third color temperature may be different from one another. For example, the first color temperature may be 3000K, the second color temperature may be 5000K, and the third color temperature may be 4000K. In some embodiments, the LED lamp **10** or LED lighting device **20** may comprise LED packages **18** configured to emit light at more than two distinct color temperatures (e.g., three, four, or more distinct color temperatures).

In example embodiments, the one or more LED packages **18** may be configured to provide light that varies in brightness, color temperature, CRI, and/or the like based on the current provided to the one or more LED packages **18** by the driver circuitry **19**. For example, the driver circuitry may provide a particular current to an LED package **18** to cause the LED package **18** to provide light having particular light aspects or qualities.

In example embodiments, the LED packages **18** may comprise one or more LED packages **18** that are configured to emit light other than “white” light. For example, the LED packages **18** may comprise one or more LED packages **18** configured to emit a red or amber light that may be operated to increase the CRI of the light emitted by the LED lamp **10** or LED lighting device **20**.

#### Example Driver Circuitry

In example embodiments, the driver circuitry **19** may be configured to provide a controlled electrical current to at least one of the LED packages **18** during operation of the LED lighting device **20** or LED lamp **10**. In various embodiments, the driver circuitry **19** may comprise a circuit portion configured to convert AC voltage into DC voltage. In some embodiments, the driver circuitry **19** may comprise a circuit portion configured to control the current flowing through the two or more LED packages **18**. In certain embodiments, the driver circuitry **19** may comprise a circuit portion configured to dim the LED lamp **10** or LED lighting fixture **20**. In various embodiments, additional circuit components may be present in the driver circuitry **19**. Similarly, in various embodiments, all or some of the circuit portions mentioned here may not be present in the driver circuitry **19**. In some embodiments, circuit portions listed herein as separate circuit portions may be combined into one circuit portion. As should be appreciated, a variety of driver circuitry configurations are generally known and understood in the art and any of such may be employed in various embodiments as suitable for the intended application, without departing from the scope of the present invention.

In example embodiments, the driver circuitry **19** may be configured to operate subsets of the two or more LED packages **18** at a particular given moment in time. For example, if a first color temperature has been selected by a user as the operating color temperature, the driver circuitry **19** may be configured to operate one or more first LED packages **18a** configured to emit light at the selected first color temperature. If a second color temperature has been selected by the user as the operating color temperature, the driver circuitry **19** may be configured to operate one or more second LED packages **18b** configured to emit light at the second selected color temperature. If a third color temperature has been selected by the user as the operating color temperature, the driver circuitry **19** may be configured to operate at least a portion of the first LED packages **18a** (e.g.,

11

half of the first LED packages **18a**) and at least a portion of the second LED packages **18b** (e.g., half of the second LED packages **18b**) to provide (e.g., via a combination of the first and second LED packages) a selected third color temperature that is a composite, mixture, or superposition of the first and second color temperatures. The selection of which LED packages **18** are operated by the driver circuitry **19**, when the LED lamp **10** or LED lighting device **20** is operated, is determined by the status of the switch **30** and/or by the switch control unit **35**. For example, the driver circuitry **19** may comprise a plurality of provider circuits **17** configured to provide a controlled electrical current to a subset of the two or more LED packages **18** depending on the selected operating color temperature and/or the status of the switch **30**.

In another example, the driver circuitry **19** may be configured to provide a particular current to one or more of the LED packages **18** to provide light having specific light aspects qualities (e.g., brightness, color temperature, CRI, and/or the like). For example, the driver circuitry **19** may be configured to drive one or more LED packages **18** such that the LED packages provide light having the desired light aspects or qualities. The determination of how one or more of the LED packages **18** should be driven (e.g., what current should be supplied to the LED packages **18**) may be determined by the status of the switch **30** and/or by the switch control unit **35**. Based on the desired light aspects or qualities, different LED packages **18** may be driven differently. For example, LED packages **18** may be driven differently from a red or amber LED package **18** that is being operated to increase the CRI of the light emitted by the LED lamp **10** or LED lighting device **20**. Thus, the provider circuits **17** may be configured to provide various LED packages **18** with a particular configurable current such that the composite light emitted by the LED lamp **10** or LED lighting device **20** has the user desired light aspects or qualities.

For example, in an example embodiment (with reference to FIG. 4) that allows a user to choose between three different operating color temperature options, the driver circuitry **19** may comprise three distinct provider circuits **17** for providing the controlled electrical current to the at least one of the two or more LED packages **18** for operation. For example, the switch control unit **35** and/or the position of the switch selector **34** may determine which provider circuit **17** is used during the operation of the LED lamp **10** or LED lighting device **20**. Generally, only one of the provider circuits **17** is in use at a given time. For example, a first provider circuit **17** may be configured to provide electrical current to one or more first LED packages **18a** when the selected operating color temperature is the first color temperature, a second provider circuit **17** may be configured to provide electrical current to one or more second LED packages **18b** when the selected operating color temperature is the second color temperature, and a third provider circuit **17** may be configured to provide electrical current to at least one first LED package **18a** and at least one second LED package **18b** when the selected operating color temperature is the third color temperature. The selection of the operating color temperature may be based at least in part on the status of a switch **30** (e.g., the position of the switch selector **34**) and/or by a switch controller unit **35**.

In example embodiments, various configurations of provider circuits **17** may be applied. For example, as noted above, a provider circuit **17** may be configured to provide electrical current to only the first LED packages **18a**, only the second LED packages **18b**, or a predetermined combi-

12

nation of the first and second LED packages **18a** and **18b**. For example, a provider circuit **17** may be configured to provide electrical current to half of the first LED packages **18a** and half of the second LED packages **18b** to provide light of the third color temperature. In another example, a provider circuit **17** may be configured to provide electrical current to 25% of the first LED packages **18a** and 75% of the second LED packages **18b** to provide light of a fourth color temperature. It should be understood that a provider circuit **17** may be configured to provide controlled electrical current to various combinations of the first LED packages **18a** and the second LED packages **18b** to provide various color temperature options. Furthermore, in example embodiments, the two or more LED packages **18** may comprise three or more LED packages **18**. For example, the LED packages **18** may comprise at least one first LED package **18a** configured to emit light at a first color temperature, at least one second LED package **18b** configured to emit light at a second color temperature, and at least one third LED package configured to emit light at a third color temperature, the first, second, and third color temperatures being different from one another. In such an embodiment, a provider circuit **17** may be configured to provide electrical current to at least one of the first LED packages **18a**, at least one of the second LED packages **18b**, and at least one of the third LED packages to provide a three color blend. It should be understood that LED packages configured to emit light at additional color temperatures may be incorporated into the LED lamp **10** or LED lighting device **20** as desired and/or appropriate for the application and that various combinations of the LED packages may be activated to cause the LED lamp **10** or LED lighting device **20** to emit light of a desired operating color temperature.

As noted above, the light aspects or qualities (e.g., brightness, color temperature, CRI, and/or the like) may be controlled by how the one or more LED packages **18** are operated (instead of and/or in addition to which of the LED packages **18** are operated). In example embodiments, one or more configurable qualities of the light emitted by the LED lamp **10** or the LED lighting device **20** may be configured by controlling the current provided to one or more of the LED packages **18**. In particular, the driver circuitry **19** may drive the one or more LED packages **18** with a higher or lower current to modify the brightness, color temperature, CRI, and/or the like of the light emitted by the one or more LED packages **18**. In another example, the driver circuitry **19** may increase or decrease the number of LED packages **18** being driven to increase or decrease the brightness of the light emitted by the LED lamp **10** or the LED lighting device **20**. In another example, one or more red or amber LED packages **18** may be turned on (e.g., electrical current may be supplied thereto by the driver circuitry **19**) to increase the CRI of the light emitted by the LED lamp **10** or LED lighting device **20**. In another example, the primary or secondary optics used to condition the light emitted by the LED lamp **10** or LED lighting device **20**. For example, the optics **13** may be modified, the amount of phosphor through which an LED is emitting may be modified, and/or the like. Thus, in example embodiments, one or more qualities of the light emitted by the LED lamp **10** or LED lighting device **20** may be modified, controlled, configured, and/or the like by changing and/or controlling the amount of current provided to one or more LED packages **18**, which LED packages **18** of the two or more LED packages **18** are being operated, physically changing the primary and/or secondary optics conditioning the light, and/or the like. Thus, for example in an embodiment configured to provide configurable bright-

ness settings or modes, the dimming of the LED lamp 10 or LED lighting device 20 may be controlled by the switch control unit 35 and/or driver circuitry 19 rather than by the externally provided current.

In example embodiments, when the LED lamp 10 or LED lighting device 20 is in a configurable operating mode, interaction with the remote switch 40 (e.g., reception of a signal from the remote switch 40) may cause the topology of the driver circuitry to be altered. For example, user interaction with the remote switch 40 may cause a signal to be provided to the switch control unit 35. The switch control unit 35 may then cause a change in the topology of the driver circuitry 19, thereby causing the driver circuitry 19 to operate a different set of LED packages 18, drive one or more LED packages 18 with a modified current, and/or the like.

#### Example Switch

In example embodiments, the LED lamp 10 and/or LED lighting device 20 comprises a switch 30. In example embodiments, the switch 30 may be configured to allow a user to select an operating mode (e.g., a programmable custom mode, a set mode, or a configurable mode). One or more aspects or qualities of the light (e.g., color temperature, brightness, CRI, and/or the like) emitted by the LED lamp 10 and/or LED lighting device 20 may then be controlled based on the user-selected operating mode. In example embodiments, the switch 30 may be a mechanical switch, electro-mechanical switch, an infrared switch, and/or the like. For example, if the switch 30 is a mechanical switch, the switch 30 may comprise a slide switch, a dial, a set of binary switches, and/or the like. In an example embodiment, the switch 30, and/or a user interface thereof, may be disposed on an exterior surface of the lamp housing 14 or the device housing 24. FIGS. 3 and 3A provide block diagrams of at least some of the electrical components of an LED lamp 10 or LED lighting device 20, including a switch 30 and a switch control unit 35, in accordance with example embodiments of the present invention. In example embodiments, the switch 30 may comprise a plurality of switch positions 32 (e.g., 32a, 32b, 32c, 32d), switch position indicators 33 (e.g., 33a, 33b, 33c, 33d), and a switch selector 34. For example, the switch 30 may comprise four switch positions 32a, 32b, 32c, and 32d, in example embodiments. In other embodiments, the switch 30 may comprise more than four switch positions 32 (e.g., 32a, 32b, 32c, 32d). For example, in various embodiments, the switch 30 may comprise two, three, four, five, six, seven, eight, or more switch positions with each switch position corresponding to either a set operating mode, a selectively configurable operating mode, or a programmable custom operating mode. One of the switch positions may correspond to a configurable operating mode (e.g., a configurable operating color temperature mode, configurable brightness mode, configurable brightness-color temperature mode, etc.) and the remaining switch positions may correspond to set operating modes (e.g., set operating color temperature modes, set brightness modes, set operating brightness-color temperature modes, etc.) wherein the different switch positions select the particular set light aspects or qualities (e.g., brightness, operating color temperature, CRI, and/or the like). For example, switch positions 32a, 32b, and 32c may correspond to set operating color temperature modes with each position corresponding to a particular set operating color temperature. The switch position 32d may correspond to a configurable operating color temperature mode.

In some embodiments, the switch 30 may provide the user with one or more programmable custom operating modes. In

an example embodiment, the switch 30 may comprise a custom set operating color temperature mode, in which a user may define and/or select a predefined mixture of the first, second, third, and/or the like operating color temperatures such that the LED lamp 10 or LED lighting device 20 provides a light at the custom set operating color temperature. In another example, the switch 30 may comprise a custom program operating brightness-color temperature operating mode such that the LED lamp 10 or LED lighting device 20 provides light at a custom set operating color temperature at a set brightness. In another example, the switch 30 may comprise a custom program operating mode wherein the switch control unit 35 is configured to cause the operating color temperature, brightness, and/or CRI to change at configurable times (e.g., clock time) or at configurable periods of time. For example, a user may wish to have the LED lamp 10 or LED lighting device 20 operate at one operating color temperature during the morning hours, another operating color temperature during the afternoon, and another operating color temperature in the evening or night time hours. In another example, a user may want the LED lamp 10 or LED lighting device 20 to operate at one operating color temperature, brightness, and/or CRI for the first twenty minutes the LED lamp 10 or LED lighting device 20 is operating and then to operate at another operating color temperature, brightness, and/or CRI for the next three hours or for as long as the LED lamp 10 or LED lighting device 20 remains in constant operation. In example embodiments having programmable custom operating mode options, additional user interface components (e.g., in addition to the switch 30) may be provided for the programming of the programmable custom operating mode. The additional user interface components may be located on the housing 14, 24 of the LED lamp 10 or LED lighting device 20 and/or on a remote switch 40 (e.g., through a mobile computing entity 40' user interface, wherein the computing entity 40' is executing an application causing the computing entity 40' to operate as a remote switch 40). In example embodiments, such additional user interface components may comprise various switches, dials, displays, touchscreen displays, buttons, knobs, and/or the like as commonly understood in the art.

A switch position indicator 33 (e.g., 33a, 33b, 33c, 33d) may correspond to each switch position 32 (e.g., 32a, 32b, 32c, 32d). The switch position indicator 33 (e.g., 33a, 33b, 33c, 33d) may be configured to indicate the operating mode (e.g., color temperature and/or option or mode, etc.) selected by placing the switch selector 34 in the corresponding switch position. For example, switch position indicator 33a may show approximately where the switch position 32a is located and may indicate the color temperature and/or option or mode selected by placing the switch selector 34 in switch position 32a. For example, the switch position indicator 33a indicates that if the switch selector 34 is placed in the switch position 32a, a set operating color temperature mode is selected with the set operating color temperature being 3000K. Similarly, the switch position indicator 33b indicates that if the switch selector 34 is placed in the switch position 32b, a set operating color temperature mode is selected with the set operating color temperature being 4000K; the switch position indicator 33c indicates that if the switch selector 34 is placed in the switch position 32c, a set operating color temperature mode is selected with the set operating color temperature being 5000K; and the switch position indicator 33d indicates that if the switch selector 34 is placed in the switch position 32d, the configurable operating color temperature mode is selected. For example, if the switch selec-

15

tor **34** is placed in switch position **34d**, the operating color temperature of the LED lamp **10** or LED lighting device **20** may be configurable by using a wall switch, remote control, and/or the like (e.g., remote switch **40** shown in FIG. 5). In another example, as shown in FIG. 4A, the switch position indicator **33a** indicates that if the switch selector **34** is placed in the switch position **32a**, a set operating mode is selected with the set light aspects or qualities being A; the switch position indicator **33b** indicates that if the switch selector **34** is placed in the switch position **32b**, a set operating mode is selected with the set light aspects or qualities being B; the switch position indicator **33c** indicates that if the switch selector **34** is placed in the switch position **32c**, a set operating mode is selected with the set light aspects or qualities being C; and the switch position indicator **33d** indicates that if the switch selector **34** is placed in the switch position **32d**, the configurable operating is selected wherein a user may use a remote switch **40** to toggle between A, B, and C, wherein A, B, and C may be operating states of any preset color temperature, brightness, CRI, and/or the like, provided each operating state is different in at least one light aspect or quality relative to one another. The status of the switch **30** is determined by the switch position **32** (e.g. **32a**, **32b**, **32c**, **32d**) in which the switch selector **34** is positioned. The switch **30** has been illustrated herein as slider switch. It should be understood however, that the switch **30** may take a variety of forms as appropriate for the application. For example, FIG. 2E illustrates an example switch **30** having a multiple position pivot switch selector **34'** having switch positions that are selected based on the angle of the pivot switch selector **34'**.

In example embodiments, a user may change the operating light aspects or qualities (e.g., operating color temperature, brightness, CRI, and/or the like) of the LED lamp **10** or LED lighting device **20** by changing the positions of the switch selector **34**. For example, in various embodiments, the user may change the position of the switch selector **34** while the LED lamp **10** or LED lighting device **20** before installation of the LED lamp **10** or LED lighting device **20**, after installation of the LED lamp **10** or LED lighting device **20** but when the LED lamp **10** or LED lighting device **20** is not in use (e.g., is turned off and not emitting light), or while the LED lamp **10** or LED lighting device **20** is in use (e.g., is turned on and is emitting light). In example embodiments, if the position of the switch selector **34** is changed while the LED lamp **10** or LED lighting device **20** is in use, causing the light aspects or qualities thereof to change, the change of the light aspects or qualities may occur within two seconds of the position of the switch selector **34** being changed.

In an example embodiment, a user-selection switch **31** (e.g., a toggle switch, button, and/or the like) may be disposed on the LED lamp **10** or LED lighting device **20** such that user-selection may be received through user-selection switch at the LED lamp **10** or LED lighting device **20**. Thus, the user may change the operating light aspects or qualities of the LED lamp **10** or LED lighting device **20** when the LED lamp **10** or LED lighting device **20** is in a configurable operating mode by interacting with the user-selection switch **31** rather than by using the remote switch **40**.

In an example embodiment, the LED lamp **10** or LED lighting device **20** comprises two switches **30**. For example, a first switch **30** may correspond to one or more set or configurable operating modes and a second switch **30** may correspond to whether the LED lamp **10** or LED lighting device **20** is a sensor adjustment mode or non-adjustment mode. In another example embodiment, only one switch **30**

16

is provided an each selectable position of the switch **30** selects an operating mode that is either a set operating mode or a configurable operating mode and either a sensor adjustment mode or a non-adjustment mode.

#### 5 Example Switch Control Unit

In example embodiments, the LED lamp **10** or LED lighting device **20** may comprise a switch control unit **35**. In example embodiments, the switch control unit **35** may be configured to cause the driver circuitry **19** to operate one or more LED packages **18** in accordance with the user-selected operating mode (e.g., a programmable custom mode, a set mode, or a configurable mode). In example embodiments, the switch control unit **35** may be a microcontroller unit (MCU). For example, the switch control unit **35** may comprise a single integrated circuit. In example embodiments, the switch control unit **35** comprises one or more processing elements **37**, one or more memory elements **36**, and/or one or more communication interface elements **38**. In example embodiments, the switch control unit **35** may be in wired (e.g., hard-wired) communication with the switch **30** and/or configured to receive signals from the remote switch **40**. In example embodiments, the switch control unit **35** may be configured to cause one or more operating light aspects or qualities (e.g., operating color temperature, brightness, CRI) of the LED lamp **10** or the LED lighting device **20** to be modified based on a received signal from the remote switch **40**, store information/data identifying the last light aspects or qualities at which the LED lamp **10** or the LED lighting device **20** was operated at, and/or the like. For example, the switch control unit **35** may be configured to receive user selection of a programmable custom operating mode and control the LED lamp **10** or the LED lighting device **20** to operate in accordance with the programmable custom operating mode or other user-selected operating mode (e.g., set operating mode or configurable operating mode).

In example embodiments, the one or more processing elements **37** (also referred to as processors, processing circuitry, processing device, and/or similar terms used herein interchangeably) that communicate with other elements within the switch control unit **35**. For example, the processing element(s) **37** may communicate with the memory element(s) **36**, communication interface element(s) **38**, and/or components of the driver circuitry **19** via direct electrical connection, a bus, and/or the like. For example, the processing element(s) **37** may be configured to process input received through the switch **30** (and/or additional user interface components), process a signal received from the remote switch **40** (e.g., through the communication interface element **38**), cause the memory element **36** to store a current operating color temperature, cause one provider circuit **17** to be activated (e.g., to provide a controlled electric current to the corresponding at least one LED package **18**), cause another provider circuit **17** to be de-activated (e.g., to stop providing an electric current to the corresponding at least one LED package **18**), cause a different and/or modified current to be provided to the provider circuit **17** (e.g., such that the LED package **18** is driven in a modified manner by the provider circuit **17**) and/or the like. As will be understood, the processing element **37** may be embodied in a number of different ways. For example, the processing element **37** may be embodied as one or more complex programmable logic devices (CPLDs), microprocessors, multi-core processors, co-processing entities, application-specific instruction-set processors (ASIPs), microcontrollers, and/or controllers. Further, the processing element **37** may be embodied as one or more other processing devices or circuitry. The term circuitry may refer to an

entirely hardware embodiment or a combination of hardware and computer program products. Thus, the processing element **37** may be embodied as integrated circuits, application specific integrated circuits (ASICs), field programmable gate arrays (FPGAs), programmable logic arrays (PLAs), hardware accelerators, other circuitry, and/or the like. As will therefore be understood, the processing element **37** may be configured for a particular use or configured to execute instructions stored in volatile or non-volatile media or otherwise accessible to the processing element **37**. As such, whether configured by hardware or computer program products, or by a combination thereof, the processing element **37** may be capable of performing steps or operations according to embodiments of the present invention when configured accordingly.

The memory element(s) **36** may be non-transitory and may include, for example, one or more volatile and/or non-volatile memories. In other words, for example, the memory element **36** may be an electronic storage device (e.g., a computer readable storage medium) comprising gates configured to store data (e.g., bits) that may be retrievable by a machine (e.g., a computing device like the processing element **37**). The memory element **36** may be configured to store information, data, content, applications, instructions, or the like for enabling the switch control unit **35** to carry out various functions in accordance with an example embodiment of the present invention. For example, the memory element **35** could be configured to buffer input data for processing by the processing element **37** (e.g., a signal received from the remote switch **40**). In example embodiments, the memory element **36** may be configured to store a most recent operating light aspects or qualities (e.g., color temperature, brightness, CRI, and/or the like, and/or combination thereof). Additionally or alternatively, the memory element **36** could be configured to store instructions for execution by the processing element **37**.

As indicated, in one embodiment, the switch control unit **35** may also include one or more communications interface elements **38** for communicating with the remote switch **40**. For example, the communications interface element **38** may be configured to receive a signal from the remote switch **40** indicating user selection of, activation of, and/or interaction with an on/off or power button, a dimmer switch, or a remote selector switch configured to select or modify the operating color temperature of the LED lamp **10** or LED lighting device **20**, and/or the like. Such communication may be executed using a wired data transmission protocol, such as fiber distributed data interface (FDDI), digital subscriber line (DSL), Ethernet, asynchronous transfer mode (ATM), frame relay, data over cable service interface specification (DOCSIS), or any other wired transmission protocol. Similarly, the communications interface element **38** may be configured to communicate via a wireless communication technology, such as a short range communication technology. For example, the communications interface element **38** may be configured to receive and/or send signals using IEEE 802.11 (Wi-Fi), Wi-Fi Direct, 802.16 (WiMAX), ultra wideband (UWB), infrared (IR) protocols, near field communication (NFC) protocols, Wibree, Bluetooth protocols, wireless universal serial bus (USB) protocols, and/or any other wireless protocol.

In example embodiments, the switch control unit **35** may be configured to cause the LED lamp **10** or LED lighting device **20** to operate at the operating color temperature, brightness, CRI, and/or other particular light aspect or quality, when the LED lamp **10** or LED lighting device **20** is turned on. For example, the switch control unit **35** may be

configured to determine the status of the switch **30** and operate the LED lamp **10** or LED lighting device **20** accordingly. For example, the switch control unit **35** may be configured to determine if the position of the switch selector **34** is a position corresponding to a set operating mode, to the position corresponding to the configurable operating mode, and/or to a position corresponding to a programmable custom operating mode. If the switch selector **34** is in a switch position **32** (e.g., **32a**, **32b**, **32c**) corresponding to a set operating mode, the switch control unit **35** (e.g., the processing element **37**) may determine the corresponding color temperature (and/or other light aspects or qualities) and cause the LED lamp **10** or LED lighting device **20** to operate at the corresponding color temperature (and/or other light aspects or qualities). For example, if the switch control unit **35** determines that the switch selector **34** is in switch position **32a**, the switch control unit **35** may then determine that the corresponding color temperature is 3000K and cause the LED lamp **10** or LED lighting device **20** to be operated at 3000K. For example, if the switch control unit **34** determines that the switch selector **34** is in the switch position **32a**, the switch control unit **35** may cause the provider circuit **17** corresponding to the switch position **32a** to provide a controlled current to at least one of the two or more LED packages **18**.

If the switch control unit **35** determines that the status of the switch **30** places the LED lamp **10** or LED lighting device **20** in the configurable operating mode, the switch control unit **35** may cause the LED lamp **10** or LED lighting device **20** to be operated at light aspects or qualities indicated by the last received signal from the remote switch **40**. For example, the memory element **36** may store an indication of the last received signal from the remote switch **40**, a current/most recently used operating color temperature, brightness, and/or CRI indicator, and/or the like such that the LED lamp **10** or the lighting device **20** may be operated at the most recently user-selected light aspects or qualities. In another example, if the switch control unit **35** determines that the status of the switch **30** places the LED lamp **10** or LED lighting device **20** in a programmable custom operating mode, the switch control unit **35** may operate the LED lamp **10** or LED lighting device **20** accordingly (e.g., based on a stored custom operating program stored in memory element **36**, and/or the like).

In example embodiments, if the status of the switch **30** corresponds to a set operating mode (e.g., a set operating color temperature, brightness, CRI, and/or the like), the switch controller unit **35** may be bypassed. For example, if the switch selector **34** is in switch position corresponding to a set operating color temperature and/or the like (e.g., **32a**, **32b**, or **32c**), the position of the switch selector **34** may cause the appropriate provider circuit **17** to be activated when the LED lamp **10** or lighting device **20** is turned on. For example, the switch position(s) corresponding to a set operating light aspects or qualities may be in direct electrical communication with the corresponding provider circuit **17** such that placement of the switch selector **34** into that switch position causes the corresponding provider circuit **17** to be completed or activated (e.g., when the LED lamp **10** or lighting device **20** is turned on). Thus, in some example embodiments, the switch control unit **35** may not be powered and/or engaged in the operation of the LED lamp **10** or lighting device **20** unless the status of the switch **30** corresponds to a configurable and/or custom programmable mode. In some embodiments, a set operating mode may set one or more light aspects or qualities, while allowing one or more other light aspects or qualities to be configured. For

19

example, a set operating mode may set the operating color temperature and CRI of the LED lamp 10 or lighting device 20 but allow the brightness to be modified. In another example, a set operating mode may set the operating color and brightness of the LED lamp 10 or lighting device 20 but allow the CRI to be modified. For example, in some example embodiments, if the status of the switch 30 corresponds to a set operating color temperature mode, the switch control unit 35 may only be used to receive and process signals from the remote switch 40 and cause corresponding actions related to turning the LED lamp 10 or lighting device 20 on or off, dimming the LED lamp 10 or lighting device 20, modifying the CRI of the LED lamp 10 or lighting device 20, and/or the like. For example, if the switch control unit 35 receives a signal attempting to change the operating color of the LED lamp 10 or lighting device 20 while the LED lamp 10 or lighting device 20 is in a set operating color temperature mode, the switch control unit 35 need not determine if the LED lamp 10 or lighting device 20 is in a set operating color temperature mode or the configurable operating color temperature mode as the switch control unit 35 cannot affect the circuit connection caused by the position of the switch selector 34.

In various embodiments, the switch control unit 35 is in communication with one or more sensors 39. For example, the switch control unit 35 may communicate with one or more sensors via the communications interface element 38. In an example embodiment, the switch control unit 35 communicates with the one or more sensors wirelessly. In an example embodiment, the switch control unit 35 is in wired communication with the one or more sensors. In an example embodiment, the LED lamp 10 or LED lighting device 20 comprises the one or more sensors 39. In various embodiments, the one or more sensors 39 may comprise light sensors, photocells, motion sensors, and/or the like. In an example embodiment, the processing element 37 is configured to receive signals from one or more sensors 39 (e.g., via the communications interface element 38) and causes the operation of the LED lamp 10 or LED lighting device 20 to be adjusted, modified, or the like based on the received signals. In an example embodiment, the processing element 37 only adjusts, modifies, or the like the operation of the LED lamp 10 or LED lighting device 20 based on signals received from one or more sensors 39 when the status of the switch 30 corresponds to a configurable operating mode. In an example embodiment, the processing element 37 adjusts, modifies, or the like the operation of the LED lamp 10 or LED lighting device 20 based signals received from the one or more sensors 39 when the status of the switch 30 corresponds to a set operating mode such that the light in the room or space where the LED lamp 10 or LED lighting device 20 is located is in accordance with the user selected set operating mode.

In an example embodiment, the sensor is a light sensor or photo sensor and the adjusting, modifying, or the like of the operation of the LED lamp 10 or LED lighting device 20 comprises dimming or brightening the light emitted by the LED lamp 10 or LED lighting device 20 such that the brightness in the room or space where the LED lamp 10 or LED lighting device 20 is located (e.g., due to natural light, light emitted by the LED lamp 10 or LED lighting device 20, and/or other light sources) is in accordance with a predefined threshold or goal brightness level. In an example embodiment, the sensor is a light sensor or photo sensor and the adjusting, modifying, or the like of the operation of the LED lamp 10 or LED lighting device 20 comprises changing the color temperature or CRI of the light emitted by the LED

20

lamp 10 or LED lighting device 20 such that the brightness in the room or space where the LED lamp 10 or LED lighting device 20 is located (e.g., due to natural light, light emitted by the LED lamp 10 or LED lighting device 20, and/or other light sources) is in accordance with a predefined goal color temperature or CRI. In an example embodiment, the adjusting, modifying, or the like of the operation of the LED lamp 10 or LED lighting device 20 comprises dimming or brightening the light emitted by the LED lamp 10 or LED lighting device 20 in response to a motion sensor detecting the presence of a person in the room or space or having not detected the presence of anyone in the room or space for a predetermined threshold amount of time.

Example Remote Switch

Example embodiments of the present invention comprise a remote switch 40. In example embodiments, a remote switch 40 may be a wall mounted switch mounted in the same room as the LED lamp 10 or LED lighting device 20 and/or within a short range communication technology range of the LED lamp 10 or LED lighting device 20. For example, the remote switch 40 may be a wall and/or junction box mounted toggle switch, dimmer switch and/or the like in wired communication with the switch control unit 35. In another example, the remote switch 40 may be a handheld device (e.g., a remote control, or computing entity 40') that is within the same room as the LED lamp 10 or LED lighting device 20, within a short range communication technology range of the LED lamp 10 or LED lighting device 20, in communication with the switch control unit 35 through a wireless network, and/or the like. In example embodiments, the remote switch 40 may be in wired or wireless communication with the switch control unit 35. For example, the remote switch 40 may be configured to control the operation of the LED lamp 10 or lighting device 20 or aspects thereof by providing a signal to the switch control unit 35 indicating user selection, interaction, and/or the like with one or more interactive elements of the remote switch 40. For example, the remote switch 40 may be configured to allow a user to toggle through two or more operating color temperatures, brightness, CRIs, and/or other light aspects or qualities of the LED lamp 10 or LED lighting device 20. In example embodiments, the toggling of the remote switch 40 to change or modify the operating light aspects or qualities could be at any time interval from 1 ms to 1 min.

For example, the remote switch 40 may be configured to cause the LED lamp 10 or lighting device 20 to turn on or off, control the brightness of the LED lamp 10 or lighting device 20 (e.g., through a dimmer switch), change the operating light aspects or qualities of the LED lamp 10 or lighting device 20, program a programmable custom operating mode, and/or the like. An example remote switch 40 is illustrated in FIG. 5. In example embodiments, the remote switch 40 comprises one or more interactive elements (e.g., 42, 44). For example, the remote switch 40 may comprise an on/off and/or dimmer switch 42 configured to turn the LED lamp 10 (e.g., the lighting device that the LED lamp 10 is secured within) or LED lighting device 20 on or off and/or control the brightness of the LED lamp 10 or the LED lighting device 20. The remote switch 40 may comprise a remote selector 44 (e.g., a color temperature control) configured for remotely selecting an operating color temperature of the LED lamp 10 or lighting device 20 when the LED lamp 10 or LED lighting device 20 is in the configurable operating mode wherein the operating color temperature may be toggled between color temperature A, color temperature B, and color temperature C. For example, a user may select the remote selector 44 to cause the operating

21

color temperature of the LED lamp **10** or lighting device **20** to change from color temperature A to color temperature B, from color temperature B to color temperature C, or from color temperature C to color temperature A. In another example, the remote selector **44** may comprise a button and/or the like for each of the first, second, and third color temperatures and the user may select, press, interact with, and/or the like the button corresponding to the desired color temperatures. In another example, the remote selector **44** may comprise a switch or dial having a switch or dial position corresponding to each of selectable color temperatures. In example embodiments, the remote selector **44** may be a slide, push button, rotary, passive infrared and/or other type of interactive element that the user may interact with, select, press, touch, voice activate, and/or the like. Thus, the remote selector **44** may be configured to allow a user to select a desired operating color temperature, brightness, CRI, and/or other operating light aspects or qualities, and/or a combination thereof during operation of the LED lamp **10** or LED lighting device **20** (e.g., when the LED lamp **10** or LED lighting device **20** is in the configurable operating mode). In example embodiments, the remote switch **40** may comprise additional user interface components as appropriate for the application.

The remote switch **40** may further comprise a communication interface **48**. In example embodiments, the communication interface **48** may be a part of a control unit that is similar to the switch control unit **35** (e.g., the control unit may comprise a processing element and/or memory element in addition to the communication interface **48**). In example embodiments, the communication interface **48** is configured to provide a signal to the communication interface element **38** indicating user selection and/or interaction with the on/off and/or dimmer switch **42**, the remote selector **44**, and/or the like.

For example, the communications interface **48** may be configured to communicate with the switch control unit **35**. For example, the communications interface **48** may be configured to provide a signal to the communications interface element **38** indicating user selection of, activation of, and/or interaction with an on/off and/or dimmer switch **42**, remote selector **44**, and/or the like. Such communication may be executed using a wired data transmission protocol, such as fiber distributed data interface (FDDI), digital subscriber line (DSL), Ethernet, asynchronous transfer mode (ATM), frame relay, data over cable service interface specification (DOCSIS), or any other wired transmission protocol. Similarly, the communications interface **48** may be configured to communicate via a wireless communication technology, such as a short range communication technology. For example, the communications interface **48** may be configured to receive and/or send signals using IEEE 802.11 (Wi-Fi), Wi-Fi Direct, 802.16 (WiMAX), ultra wideband (UWB), infrared (IR) protocols, near field communication (NFC) protocols, Wibree, Bluetooth protocols, wireless universal serial bus (USB) protocols, and/or any other wireless protocol.

#### Example Computing Device Used as a Remote Switch

FIG. 6 provides an illustrative schematic representative of a computing entity **40'** that can be used in conjunction with embodiments of the present invention. In particular, the computing entity **40'** may be configured to operate and/or execute an application configured to cause the computing entity **40'** to act as a remote switch **40**. For example, the computing entity **40'** may operate and/or execute an application configured to communicate with the switch control unit **35** and/or cause one or more aspects (e.g., brightness,

22

CRI, color temperature, and/or the like and/or a combination thereof) of light emitted by the LED lamp **10** or LED lighting device **20** to be modified. In example embodiments, the computing entity **40'** may be a mobile computing entity such as a mobile phone, tablet, phablet, wearable computing device, personal digital assistant (PDA), MP3 player, and/or the like. In an example embodiment, the remote switch **40** may be a building control system (e.g., a digital addressable lighting interface (DALI)-based building control system).

As shown in FIG. 6, a computing entity **40'** can include an antenna **412**, a transmitter **404** (e.g., radio), a receiver **406** (e.g., radio), and a processing element **408** that provides signals to and receives signals from the transmitter **404** and receiver **406**, respectively. The signals provided to and received from the transmitter **404** and the receiver **406**, respectively, may include signaling information/data in accordance with an air interface standard of applicable wireless systems to communicate with various entities, such as switch control unit **35**, another computing entity **40'**, and/or the like. In this regard, the computing entity **40'** may be capable of operating with one or more air interface standards, communication protocols, modulation types, and access types. More particularly, the computing entity **40'** may operate in accordance with any of a number of wireless communication standards and protocols. In a particular embodiment, the computing device **40'** may operate in accordance with multiple wireless communication standards and protocols, such as GPRS, UMTS, CDMA2000, 1xRTT, WCDMA, TD-SCDMA, LTE, E-UTRAN, EVDO, HSPA, HSDPA, Wi-Fi, WiMAX, UWB, IR protocols, Bluetooth protocols, USB protocols, and/or any other wireless protocol.

Via these communication standards and protocols, the computing entity **40'** can communicate with various other entities using concepts such as Unstructured Supplementary Service information/data (USSD), Short Message Service (SMS), Multimedia Messaging Service (MMS), Dual-Tone Multi-Frequency Signaling (DTMF), and/or Subscriber Identity Module Dialer (SIM dialer). The computing entity **40'** can also download changes, add-ons, and updates, for instance, to its firmware, software (e.g., including executable instructions, applications, program modules), and operating system.

According to one embodiment, the computing entity **40'** may include location determining aspects, devices, modules, functionalities, and/or similar words used herein interchangeably. For example, the computing entity **40'** may include outdoor positioning aspects, such as a location module adapted to acquire, for example, latitude, longitude, altitude, geocode, course, direction, heading, speed, UTC, date, and/or various other information/data. In one embodiment, the location module can acquire data, sometimes known as ephemeris data, by identifying the number of satellites in view and the relative positions of those satellites. The satellites may be a variety of different satellites, including LEO satellite systems, DOD satellite systems, the European Union Galileo positioning systems, the Chinese Compass navigation systems, Indian Regional Navigational satellite systems, and/or the like. Alternatively, the location information/data may be determined by triangulating the computing entity's **40'** position in connection with a variety of other systems, including cellular towers, Wi-Fi access points, and/or the like. Similarly, the computing entity **40'** may include indoor positioning aspects, such as a location module adapted to acquire, for example, latitude, longitude, altitude, geocode, course, direction, heading, speed, time, date, and/or various other information/data. Some of the

indoor aspects may use various position or location technologies including RFID tags, indoor beacons or transmitters, Wi-Fi access points, cellular towers, nearby computing devices (e.g., smartphones, laptops) and/or the like. For instance, such technologies may include iBeacons, Gimbal proximity beacons, BLE transmitters, Near Field Communication (NFC) transmitters, and/or the like. These indoor positioning aspects can be used in a variety of settings to determine the location of someone or something to within inches or centimeters.

The computing entity 40' may also comprise a user interface (that can include a display 416 coupled to a processing element 408) and/or a user input interface (coupled to a processing element 408). For example, the user interface may be an application, browser, user interface, dashboard, webpage, and/or similar words used herein interchangeably executing on and/or accessible via the computing entity 40' to interact with and/or cause display of information. The user input interface can comprise any of a number of devices allowing the computing entity 40' to receive data, such as a keypad 418 (hard or soft), a touch display, voice/speech or motion interfaces, scanners, readers, or other input device. In embodiments including a keypad 418, the keypad 418 can include (or cause display of) the conventional numeric (0-9) and related keys (#, \*), and other keys used for operating the computing entity 40' and may include a full set of alphabetic keys or set of keys that may be activated to provide a full set of alphanumeric keys. In addition to providing input, the user input interface can be used, for example, to activate or deactivate certain functions, such as screen savers and/or sleep modes. Through such inputs the computing entity 40' can collect contextual information/data as part of the telematics data.

The computing entity 40' can also include volatile storage or memory 422 and/or non-volatile storage or memory 424, which can be embedded and/or may be removable. For example, the non-volatile memory may be ROM, PROM, EPROM, EEPROM, flash memory, MMCs, SD memory cards, Memory Sticks, CBRAM, PRAM, FeRAM, RRAM, SONOS, racetrack memory, and/or the like. The volatile memory may be RAM, DRAM, SRAM, FPM DRAM, EDO DRAM, SDRAM, DDR SDRAM, DDR2 SDRAM, DDR3 SDRAM, RDRAM, RIMM, DIMM, SIMM, VRAM, cache memory, register memory, and/or the like. The volatile and non-volatile storage or memory can store databases, database instances, database management system entities, data, applications, programs, program modules, scripts, source code, object code, byte code, compiled code, interpreted code, machine code, executable instructions, and/or the like to implement the functions of the computing entity 40'. Example Method of Operating an LED Lamp or LED Lighting Device

FIG. 7 provides a flowchart illustrating processes and procedures for an example method for operating an LED lamp 10 or LED lighting device 20. Starting at block 102, a user uses the switch 30 to select the preferred operation mode for the LED lamp 10 or LED lighting device 20. For example, the user may place the switch selector 34 in the desired switch position 32 (e.g., 32a, 32b, 32c, 32d). For example, the switch 30 may be used to select one of the set operating modes or the configurable operating mode. In an example embodiment, the switch 30 may be used to select a programmable custom operating mode.

At block 104, the LED lamp 10 or LED lighting device 20 may be installed. For example, the LED lamp 10 may be secured within a socket of a lighting device. In another example, the LED lighting device 20 may be put into

electrical connection with line voltage by plugging a two- or three-prong polarized plug into a wall receptacle and the LED lighting device 20 may be placed in a desired position. In another example, the LED lighting device 20 may be electrically connected to line voltage by connecting wires of the LED lighting device 20 to line voltage wires of a junction box and mounting the LED lighting device 20 to a ceiling, wall, and/or the like.

At some time after the LED lamp 10 or LED lighting device 20 is installed, the LED lamp 10 or lighting device 20 is turned on, at block 112. For example, a user may turn on the LED lamp 10 or LED lighting device 20 by interacting with, selecting, pressing, and/or the like an on/off or power button, switch, and/or the like. For example, the user may interact with, select, press, and/or the like the on/off and/or dimmer switch 42 on the remote switch 40, the remote switch 40 may provide an on/off signal to the switch control unit 35, and the switch control unit 35 may cause the LED lamp 10 or LED lighting device 20 to turn on.

At block 114, it may be determined if the LED lamp 10 or LED lighting device 20 is in a set operating mode. For example it may be determined if the switch 30 was set in a position indicating that the LED lamp 10 or LED lighting device 20 is to be operated in a set operating mode (e.g., with set light aspects or qualities). For example, the switch controller unit 35 (e.g., the processing element 37) may determine if the LED lamp 10 or LED lighting device 20 is in a set operating mode. In some embodiments, determining if the LED lamp 10 or LED lighting device 20 is in a set operating mode does not require an active determination. For example, the switch 30 may be wired such that if the switch selector 34 is in set operating mode switch position, the switch control unit 35 may be bypassed and the provider circuit 17 corresponding to the selected set operating light aspects or qualities may be activated, completed, and/or the like causing the LED lamp 10 or LED lighting device 20 to be operated at the set operating light aspects or qualities.

If, at block 114, it is determined that the LED lamp 10 or LED lighting device 20 is in a set operating mode, the LED lamp 10 or LED lighting device 20 is operated at the set operating light aspects or qualities (e.g., color temperature, brightness, CRI, and/or the like), at block 116. For example, the driver circuitry 19 may operate at least one of the two or more LED packages 18 to cause the LED lamp 10 or LED lighting device 20 to emit light at the set operating color temperature.

If, at block 114, it is determined that the LED lamp 10 or LED lighting device 20 is not in a set operating mode, the process continues to block 118. At block 118, the color temperature that the LED lamp 10 or LED lighting device 20 was last operated at is identified. For example, the switch control unit 35 (e.g., the processing element 37, memory element 36, and/or the like) may identify the color temperature, brightness, CRI, and/or the like that the LED lamp 10 or LED lighting device 20 was last operated at. For example, the memory element 36 may store the most recent operating color temperature, brightness, CRI, and/or the like (and/or an indicator thereof), which may be used to identify the light aspects or qualities that the LED lamp 10 or LED lighting device 20 was last operated at. For example, the identified color temperature is applied or implemented as the operating color temperature.

At block 120, the LED lamp 10 or LED lighting device 20 is operated to provide light having the determined or identified light aspects or qualities. For example, the switch control unit 35 may cause the driver circuitry 19 to operate the LED lamp 10 or LED lighting device 20 at the operating

25

light aspects or qualities (e.g., color temperature, brightness, CRI, and/or the like, and/or a combination thereof). For example, the driver circuitry **19** may operate at least one of the two or more LED packages **18** to cause the LED lamp **10** or LED lighting device **20** to emit light at the operating light aspects or qualities. For example, the driver circuitry **19** may operate a specific set of LED packages **18** to cause the LED lamp **10** or LED lighting device **20** to emit light at the operating color temperature (and/or brightness and/or CRI). In another example, the driver circuitry **19** may drive one or more LED packages **18** such that the LED lamp **10** or LED lighting device **20** emits light at the operating color temperature (and/or brightness and/or CRI). In yet another example, the switch control unit **35** may adjust one or more optical elements to cause the LED lamp **10** or LED lighting device **20** to emit light at the operating color temperature (and/or brightness and/or CRI).

At block **122**, it is determined if a light aspect or quality change signal is received. For example, the switch control unit **35** may determine if a light aspect or quality change signal is received from the remote switch **40**. For example, the signal may indicate user selection of the color selector **44**, indicating the user would like to change the operating color temperature of the LED lamp **10** or the LED lighting device **20**. For example, it is determined if a light aspect or quality change signal is received by the communication interface element **38**. If, at block **122**, it is determined that a light aspect or quality change signal is not received, the process returns to block **120**.

If, at block **122**, it is determined that a light aspect or quality change signal has been received, one or more operating light aspects or qualities of the LED lamp **10** or LED lighting device **20** are modified accordingly. For example, the switch control unit **35** may activate a provider circuit **17** corresponding to the modified operating color temperature (and/or brightness and/or CRI, and/or the like) and may de-activate the previously activated provider circuit **17** corresponding to the previous operating color temperature (and/or brightness and/or CRI, and/or the like). For example, the switch control unit **35** may cause one provider circuit **17** to provide a controlled electric current to the corresponding at least one LED package **18** such that the LED lamp **10** or LED lighting device **20** emits light having the modified operating light aspects or qualities and cause another provider circuit **17** to stop providing an electric current to the corresponding at least one LED package **18** corresponding to the previous operating light aspect or qualities. For example, the memory element **36** may be updated to indicate the new most recent operating light aspects or qualities. In example embodiments, the switch control unit **35** and/or driver circuitry **19** are configured to start operating the at least one of the two or more LED packages **18** at the modified operating light aspects or qualities within two seconds or less of the receipt of the signal indicating user-selection of the modified operating light aspects or qualities. After the one or more operating light aspects or qualities are modified, the process returns to block **120**.  
Alternative Example Method of Operating an LED Lamp or LED Lighting Device

FIG. **8** provides a flowchart illustrating processes and procedures for an alternative method for operating an LED lamp **10** or LED lighting device **20**. Starting at block **202**, a user uses the switch **30** to select the preferred operation mode for the LED lamp **10** or LED lighting device **20**. For example, the user may place the switch selector **34** in the desired switch position **32** (e.g., **32a**, **32b**, **32c**, **32d**). For example, the switch **30** may be used to select one of the set

26

operating modes or the configurable operating mode. In an example embodiment, the switch **30** may be used to select a programmable custom operating mode.

At block **204**, the LED lamp **10** or LED lighting device **20** may be installed. For example, the LED lamp **10** may be secured within a socket of a lighting device. In another example, the LED lighting device **20** may be put into electrical connection with line voltage by plugging a two- or three-prong polarized plug into a wall receptacle and the LED lighting device **20** may be placed in a desired position. In another example, the LED lighting device **20** may be electrically connected to line voltage by connecting wires of the LED lighting device **20** to line voltage wires of a junction box and mounting the LED lighting device **20** to a ceiling, wall, and/or the like. In yet another example, a wiring harness terminating in a standard size lamp base connector may be secured into the socket of a recessed lighting fixture. The LED lighting device **20** may then be placed, mounted, installed, and/or the like in a desired position.

At some time after the LED lamp **10** or LED lighting device **20** is installed, the LED lamp **10** or lighting device **20** is turned on, at block **212**. For example, a user may turn on the LED lamp **10** or lighting device **20** by interacting with, selecting, pressing, and/or the like an on/off or power button, switch, and/or the like. For example, the user may interact with, select, press, and/or the like the on/off and/or dimmer switch **42** on the remote switch **40**, the remote switch **40** may provide an on/off signal to the switch control unit **35**, and the switch control unit **35** may cause the LED lamp **10** or LED lighting device **20** to turn on.

At block **214**, the color temperature that the LED lamp **10** or LED lighting device **20** was last operated at is identified. For example, the switch control unit **35** (e.g., the processing element **37**, memory element **36**, and/or the like) may identify the color temperature that the LED lamp **10** or LED lighting device **20** was last operated at. For example, the memory element **36** may store the most recent operating light aspects or qualities, which may be used to identify the color temperature, brightness, CRI, and/or the like that the LED lamp **10** or LED lighting device **20** was last operated at. For example, the identified light aspects or qualities are applied or implemented as the operating light aspects or qualities.

At block **216**, the LED lamp **10** or LED lighting device **20** is operated at the operating light aspects or qualities. For example, the switch control unit **35** may cause the driver circuitry **19** to operate the LED lamp **10** or LED lighting device **20** at the operating light aspects or qualities (e.g., color temperature, brightness, CRI, and/or the like). For example, the driver circuitry **19** may operate at least one of the two or more LED packages **18** to cause the LED lamp **10** or LED lighting device **20** to emit light at the operating color temperature. For example, the driver circuitry **19** may operate a specific set of LED packages **18** to cause the LED lamp **10** or LED lighting device **20** to emit light at the operating color temperature (and/or brightness and/or CRI). In another example, the driver circuitry **19** may drive one or more LED packages **18** such that the LED lamp **10** or LED lighting device **20** emits light at the operating color temperature (and/or brightness and/or CRI). In yet another example, the switch control unit **35** may adjust one or more optical elements to cause the LED lamp **10** or LED lighting device **20** to emit light at the operating color temperature (and/or brightness and/or CRI and/or the like).

At block **218**, it is determined if a light aspect or quality change signal is received. For example, the switch control

unit **35** may determine if a light aspect or quality change signal is received from the remote switch **40**. For example, the signal may indicate user selection of the color selector **44**, indicating the user would like to change one or more operating light aspects or qualities of the LED lamp **10** or the LED lighting device **20**. In another example, the signal may indicate user selection of the dimmer switch **42**, indicating the user would like to change the brightness of the light emitted by the LED lamp **10** or the LED lighting device **20**. For example, it is determined if a light aspect or quality change signal is received by the communication interface element **38**. If, at block **218**, it is determined that a light aspect or quality change signal is not received, the process returns to block **216**.

If, at block **218**, it is determined that a light aspect or quality change signal has been received, it is determined if the LED lamp **10** or LED lighting device **20** is in a set operating mode, at block **220**. For example it may be determined if the switch **30** was set in a position indicating that the LED lamp **10** or LED lighting device **20** is to be operated in a set operating mode. For example, the switch control unit **35** (e.g., processing elements **37**) may determine if the LED lamp **10** or LED lighting device **20** is to be operated in a set operating mode. In some embodiments, determining if the LED lamp **10** or LED lighting device **20** is in a set operating mode does not require an active determination. For example, the switch **30** may be wired such that if the switch selector **34** is in set operating mode switch position, the switch control unit **35** may be bypassed and the provider circuit **17** corresponding to the selected set operating mode (e.g., a set operating color temperature) may be activated, completed, and/or the like causing the LED lamp **10** or LED lighting device **20** to be operated at the set operating light aspects or qualities.

If, at block **220**, it is determined that the LED lamp **10** or LED lighting device **20** is in a set operating mode, the process returns to block **216** without modifying the operating light aspects or qualities. If, at block **220**, it is determined that the LED lamp **10** or LED lighting device **20** is not in a set operating mode, the process continues to block **222**.

At block **222**, the operating light aspects or qualities of the LED lamp **10** or LED lighting device **20** are modified in accordance with the received light aspect or quality change signal. For example, the switch control unit **35** may activate a provider circuit **17** corresponding to a modified operating color temperature and may de-activate the previously activated provider circuit **17** corresponding to the previous operating color temperature. For example, the switch control unit **35** may cause one provider circuit **17** to provide a controlled electric current to the corresponding at least one LED package **18** such that the LED lamp **10** or LED lighting device **20** emits light at the modified operating color temperature (and possibly at a modified brightness and/or CRI) and cause another provider circuit **17** to stop providing an electric current to the corresponding at least one LED package **18**. For example, the memory element **36** may be updated to indicate the new most recent operating light aspects or qualities. In example embodiments, the switch control unit **35** and/or driver circuitry **19** are configured to start operating the at least one of the two or more LED packages **18** at the modified operating light aspects or qualities within two seconds or less of the receipt of the signal indicating user-selection of the second operating light aspects or qualities. After the operating light aspects or qualities are modified, the process returns to block **216**.

In example embodiments, an LED lamp **10** or LED lighting device **20** may be configured to provide a program-

mable custom operating mode. For example, a user may select a custom operating color temperature (and/or brightness and/or CRI and/or the like) and/or program the LED lamp **10** or LED lighting device **20** (e.g., the switch control unit **35** thereof) to operate the LED lamp **10** or LED lighting device **20** in accordance with a custom programmed temporal operating program. For example, with reference to FIG. **8**, at block **202**, the switch **30** of the LED lamp **10** or the LED lighting device **20** may be placed in a position corresponding to a programmable custom operating mode. The user may further program the programmable custom operating mode (e.g., using the switch **30**, additional user interface components, remote switch **40**, and/or the like). In an example embodiment, programming programmable custom operating mode may comprise providing input identifying a custom operating color, selecting a brightness, selecting a CRI, and/or the like. For example, the LED lamp **10** or LED lighting device **20** may comprise first LED packages **18a** and second LED packages **18b**, wherein the first LED packages **18a** are configured to emit light of a different color temperature than the second LED packages **18b**. The switch control unit **35** may be configured to determine a ratio of the number of first LED packages **18a** to the number of second LED packages **18b** that should be activated to provide the custom operating color temperature. For example, the first LED packages **18a** may be configured to emit light at 3000K and the second LED packages **18b** may be configured to emit light at 5000k. The programmable custom operating color temperature may be programmed to be 4500K. In this example, the switch control unit **35** may be configured to determine that one-fourth of the first LED packages **18a** and three-fourths of the second LED packages **18b** should be activated to provide a light at a color temperature of 4500K. The switch control unit **35** may then be configured to activate one or more provider circuits **17** in order to activate the appropriate LED packages **18** when the LED lamp **10** or LED lighting device **20** is turned on to provide light of the programmed custom operating color temperature. In another example, the switch control unit **35** may determine how one or more LED packages **18** should be driven to provide light having the user-selected light aspects or qualities. In another example, the switch control unit **35** may cause the primary or secondary optics, the amount of phosphor conditioning light from one or more LED packages **18**, and/or the like to be modified such that the LED lamp **10** or LED lighting device **20** emits light having the user-selected light aspects or qualities. At block **204**, the LED lamp **10** or LED lighting device **20** may be installed.

At some time after the LED lamp **10** or LED lighting device **20** is installed, the LED lamp **10** or lighting device **20** is turned on, at block **212**. For example, a user may turn on the LED lamp **10** or lighting device **20** by interacting with, selecting, pressing, and/or the like an on/off or power button, switch, and/or the like. For example, the user may interact with, select, press, and/or the like the on/off and/or dimmer switch **42** on the remote switch **40**, the remote switch **40** may provide an on/off signal to the switch control unit **35**, and the switch control unit **35** may cause the LED lamp **10** or LED lighting device **20** to turn on.

At block **214**, the light aspects or qualities (e.g., color temperature, brightness, CRI, and/or the like) that the LED lamp **10** or LED lighting device **20** are to be operated at may be identified. For example, the color temperature the LED lamp **10** or LED lighting device **20** was last operated at may be identified. In another example, the memory element **36** may be accessed (e.g., by the processing element **37**) to

identify the appropriate operating light aspects or qualities based on the programmed custom operating mode, the time of day, and/or the like. If the LED lamp **10** or LED lighting device **20** is in a programmable custom operating mode in which a custom operating color temperature has been programmed, the switch control unit **35** may determine the appropriate combination of LED packages **18** to be activated to provide light of the custom operating color temperature and the corresponding provider circuits **17** that are to be activated, the current at which the provider corresponding provider circuits **17** are to be activated with, and/or the like.

At block **216**, the LED lamp **10** or LED lighting device **20** is operated at the identified operating light aspects or qualities. For example, the switch control unit **35** may cause the driver circuitry **19** to operate the LED lamp **10** or LED lighting device **20** at the operating light aspects or qualities. For example, the driver circuitry **19** may operate at least one of the two or more LED packages **18** to cause the LED lamp **10** or LED lighting device **20** to emit light at the identified operating color temperature. For example, the appropriate provider circuits for providing the identified operating color temperature are activated such that the LED lamp **10** or LED lighting device **20** provides light of the user-selected operating color temperature. For example, the driver circuitry **19** may drive one or more LED packages **18** to provide light having the identified light aspects or qualities.

At block **218**, it is determined if a light aspect or quality change signal is received. If a light aspect or quality change signal has not been received (e.g., as determined by the switch control unit **35**), the process returns to block **216**. If a light aspect or quality change signal is received, the process continues to step **220**, wherein it is determined if the LED lamp **10** or LED lighting device **20** is in a set operating mode. In some embodiments, the programmable custom operating mode may be a set mode, wherein the operating color temperature (and/or other light aspects or qualities) of the LED lamp **10** or LED lighting device **20** cannot be modified during operation of the LED lamp **10** or LED lighting device **20**. In some example embodiments, the programmable custom operating mode may be a selectively configurable mode, wherein the operating color temperature (or other light aspect or quality) of the LED lamp **10** or LED lighting device **20** may be modified during operation of the LED lamp **10** or LED lighting device **20**. For example, the operating color temperature of the LED lamp **10** or LED lighting device **20** may be switched between one or more predefined color temperatures (e.g., the first, second, and third color temperatures) and the programmed custom operating color temperature (and/or brightness and/or CRI and/or the like). Thus, the switch control unit **35** may determine (e.g., based on the status of the switch **30** and/or one or more programs and/or the like stored by the memory element **36**) if the LED lamp **10** or LED lighting device **20** is in a set mode or a configurable mode.

If it is determined that the LED lamp **10** or LED lighting device **20** is in a set mode, the process returns to block **216**, and the LED lamp **10** or LED lighting device **20** continues to provide light at the operating light aspects or qualities. If it is determined that the LED lamp **10** or LED lighting device **20** is in a configurable mode, the process continues to block **222**. At block **222**, the operating light aspects or qualities are modified in accordance with the received light aspect or quality change signal. The process then returns to block **216**.

Example Method of Operating an LED Lamp or LED Lighting Device Using a Sensor

FIG. **9** provides a flowchart illustrating processes and procedures for an alternative method for operating an LED lamp **10** or LED lighting device **20** based on signals received from one or more sensors **39**. Starting at block **302**, a user uses the switch **30** to select the preferred operation mode for the LED lamp **10** or LED lighting device **20**. For example, the user may place the switch selector **34** in the desired switch position **32** (e.g., **32a**, **32b**, **32c**, **32d**). For example, the switch **30** may be used to select one of the set operating modes or the configurable operating mode. In an example embodiment, the switch **30** may be used to select a programmable custom operating mode. In an example embodiment, the switch **30** may be used to select a sensor-based or sensor-controlled operating mode.

At block **304**, the LED lamp **10** or LED lighting device **20** may be installed. For example, the LED lamp **10** may be secured within a socket of a lighting device. In another example, the LED lighting device **20** may be put into electrical connection with line voltage by plugging a two- or three-prong polarized plug into a wall receptacle and the LED lighting device **20** may be placed in a desired position. In another example, the LED lighting device **20** may be electrically connected to line voltage by connecting wires of the LED lighting device **20** to line voltage wires of a junction box and mounting the LED lighting device **20** to a ceiling, wall, and/or the like. In yet another example, a wiring harness terminating in a standard size lamp base connector may be secured into the socket of a recessed lighting fixture. The LED lighting device **20** may then be placed, mounted, installed, and/or the like in a desired position. In various embodiments, the LED lamp **10** or LED lighting device **20** may comprise one or more sensors **39**. In an example embodiment, the LED lamp **10** or LED lighting device **20** does not comprise one or more sensors **39** and installation comprises installing the one or more sensors **39** and placing the one or more sensors **39** in communication with the switch control unit **35**. For example, the one or more sensors **39** may be paired with the LED lamp **10** or LED lighting device **20** such that the one or more sensors **39** and the LED lamp **10** or LED lighting device **20** may communicate via Bluetooth, low energy Bluetooth, and/or the like.

At some time after the LED lamp **10** or LED lighting device **20** is installed, the LED lamp **10** or lighting device **20** is turned on, at block **312**. For example, a user may turn on the LED lamp **10** or lighting device **20** by interacting with, selecting, pressing, and/or the like an on/off or power button, switch, and/or the like. For example, the user may interact with, select, press, and/or the like the on/off and/or dimmer switch **42** on the remote switch **40**, the remote switch **40** may provide an on/off signal to the switch control unit **35**, and the switch control unit **35** may cause the LED lamp **10** or LED lighting device **20** to turn on.

At block **314**, the color temperature that the LED lamp **10** or LED lighting device **20** was last operated at is identified. For example, the switch control unit **35** (e.g., the processing element **37**, memory element **36**, and/or the like) may identify the color temperature that the LED lamp **10** or LED lighting device **20** was last operated at. For example, the memory element **36** may store the most recent operating light aspects or qualities, which may be used to identify the color temperature, brightness, CRI, and/or the like that the LED lamp **10** or LED lighting device **20** was last operated at. For example, the identified light aspects or qualities are applied or implemented as the operating light aspects or qualities.

31

At block 316, the LED lamp 10 or LED lighting device 20 is operated at the operating light aspects or qualities. For example, the switch control unit 35 may cause the driver circuitry 19 to operate the LED lamp 10 or LED lighting device 20 at the operating light aspects or qualities (e.g., color temperature, brightness, CRI, and/or the like). For example, the driver circuitry 19 may operate at least one of the two or more LED packages 18 to cause the LED lamp 10 or LED lighting device 20 to emit light at the operating color temperature. For example, the driver circuitry 19 may operate a specific set of LED packages 18 to cause the LED lamp 10 or LED lighting device 20 to emit light at the operating color temperature (and/or brightness and/or CRI). In another example, the driver circuitry 19 may drive one or more LED packages 18 such that the LED lamp 10 or LED lighting device 20 emits light at the operating color temperature (and/or brightness and/or CRI). In yet another example, the switch control unit 35 may adjust one or more optical elements to cause the LED lamp 10 or LED lighting device 20 to emit light at the operating color temperature (and/or brightness and/or CRI and/or the like).

At block 318, a sensor signal is received from the one or more sensors 39. For example, the one or more sensors 39 may provide a sensor signal to the switch control unit 35 (e.g., via a wired or wireless communication). The switch control unit 35 may receive the sensor signal (e.g., via the communications interface element 38) and process the sensor signal (e.g., via the processing element 37). For example, the one or more sensors 39 may comprise a motion sensor and the sensor signal may indicate that a person or a motion has been detected in the room or space and therefore that the LED lamp 10 or LED lighting device 20 should be turned on, brightened, and/or the like. In another example, the one or more sensors 39 may comprise a motion sensor and the sensor signal may indicate that no people or no motion has been detected in the room or space for a predetermined threshold amount of time and therefore that the LED lamp 10 or LED lighting device 20 should be turned off, dimmed, and/or the like. In another example, the one or more sensors 39 may comprise a light level sensor, a photocell, and/or the like configured to determine and/or measure the ambient light level and the sensor signal may indicate the brightness and/or light level in the room or space. The operation of the LED lamp 10 or LED lighting device 20 should be modified (e.g., by the driver circuit 19 and/or switch control unit 35) to dim/brighten, change the operating color temperature, or change the CRI of the light within the room to be in accordance with user preferences and/or set preferences when taking into account the ambient light in the room (as determined by the one or more sensors 39). For example, the voltage applied to one or more of the LED packages 18 by one or more provider circuits 17 may be increased or reduced to adjust the operating light aspects or qualities based on a signal received from one or more sensors 39 integrated into the LED lamp 10 or LED lighting device 20 and/or in communication therewith (e.g., via the communications interface element 38). In another example, the one or more sensors 39 may comprise a light sensor or photocell and the sensor signal may indicate the color temperature and/or CRI in the room or space.

At block 320, it is determined if the LED lamp 10 or LED lighting device 20 is in a set operating mode. For example it may be determined if the switch 30 was set in a position indicating that the LED lamp 10 or LED lighting device 20 is to be operated in a set operating mode (and/or a non-adjustment mode). For example, the switch control unit 35 (e.g., processing elements 37) may determine if the LED

32

lamp 10 or LED lighting device 20 is to be operated in a set operating mode. In some embodiments, determining if the LED lamp 10 or LED lighting device 20 is in a set operating mode does not require an active determination. For example, the switch 30 may be wired such that if the switch selector 34 is in set operating mode switch position, the switch control unit 35 may be bypassed and the provider circuit 17 corresponding to the selected set operating mode (e.g., a set operating color temperature) may be activated, completed, and/or the like causing the LED lamp 10 or LED lighting device 20 to be operated at the set operating light aspects or qualities.

If, at block 320, it is determined that the LED lamp 10 or LED lighting device 20 is in a set operating mode (and/or non-adjustment mode), the process returns to block 316 without modifying the operating light aspects or qualities. If, at block 320, it is determined that the LED lamp 10 or LED lighting device 20 is not in a set operating mode (e.g., the LED lamp 10 or LED lighting device 20 is in a sensor adjustment mode), the process continues to block 322. In various embodiments, a sensor adjustment mode may be a configurable operating mode or a set operating mode. For example, a configurable operating mode or a set operating mode that is a sensor adjustment mode provides for a user to select the goal light qualities for the room or space where the LED lamp 10 or LED lighting device 20 is located. For example, a configurable operating mode or a set operating mode that is a non-adjustment mode provides for a user to select the operating light qualities for the LED lamp 10 or LED lighting device 20.

At block 322, the processing element 37 determines an adjustment and/or modification to be made to the operating light aspects or qualities of the LED lamp 10 or LED lighting device 20 such that the light in the room or space (e.g., due to natural light, light emitted by the LED lamp 10 or LED lighting device 20, and/or other light sources) will be in accordance with the user-selected and/or goal light qualities (e.g., a goal brightness, goal color temperature, goal CRI, and/or the like). The switch control unit 35 may then modify the operation of the LED lamp 10 or LED lighting device 20 in accordance with the determined adjustment and/or modification such that the light in the room or space is in accordance with the user-selected and/or goal light qualities. For example, the switch control unit 35 may activate a provider circuit 17 corresponding to a modified operating color temperature and may de-activate the previously activated provider circuit 17 corresponding to the previous operating color temperature. For example, the switch control unit 35 may cause one provider circuit 17 to provide a controlled electric current to the corresponding at least one LED package 18 such that the LED lamp 10 or LED lighting device 20 emits light at the modified operating color temperature (and possibly at a modified brightness and/or CRI) and cause another provider circuit 17 to stop providing an electric current to the corresponding at least one LED package 18. In example embodiments, the switch control unit 35 and/or driver circuitry 19 are configured to start operating the at least one of the two or more LED packages 18 at the modified operating light aspects or qualities within two seconds or less of the receipt of the sensor signal. After the operating light aspects or qualities are modified, the process returns to block 316.

Thus, in an example embodiment, the switch 30 can be set to an operating mode that enables the use of a motion or ambient light sensor (e.g., dusk to dawn ambient light sensor) that may be physically attached and/or apart of the LED lamp 10 or LED lighting device 20 with the ability to

select host or slave so downstream fixtures can be controlled thru the sensors on the host designated fixture. For example, the sensor on a first LED lamp 10 or LED lighting device 20 of a plurality of LED lamps 10 or LED lighting devices 20 in a space (e.g., in a room, neighboring rooms, a user selected/defined space within a building, and/or the like) may be set as the host and used to control the operation of the remaining of the plurality of LED lamps 10 or LED lighting devices 20 in the space that are set as the slaves. In an example embodiment, when the switch 30 is in the position selecting the sensor-based or sensor-controlled operating mode, the LED lamp 10 or LED lighting device 20 may be configured to receive and act on user input received from one or more remote switches 40, 40'. For example, a user may control the LED lamp 10 or LED lighting device 20 using a wall switch, Wi-Fi or other App-based control system that could be part of a building control system or other control system that would control the fixtures independently.

Conclusion

Many modifications and other embodiments of the invention set forth herein will come to mind to one skilled in the art to which the invention pertains having the benefit of the teachings presented in the foregoing descriptions and the associated drawings. Therefore, it is to be understood that the invention is not to be limited to the specific embodiments disclosed and that modifications and other embodiments are intended to be included within the scope of the appended claims. Although specific terms are employed herein, they are used in a generic and descriptive sense only and not for purposes of limitation.

That which is claimed:

1. An LED lighting device or LED lamp comprising:
  - a plurality of first LED packages each configured to emit light having a first configurable light quality;
  - a plurality of second LED packages each configured to emit light having a second configurable light quality;
  - at least one driver circuit configured to condition an electrical current provided to at least one of (a) a first group of the plurality of first LED packages or (b) a second group of the plurality of second LED packages; and
  - a control unit configured to operate the first group of the plurality of first LED packages, via the at least one driver circuit, and the second group of the plurality of second LED packages, via the at least one driver circuit, the first group of the plurality of first LED packages and the second group of the plurality of second LED packages operated independently of one another, the control unit being: (a) in communication with a sensor located in a space, the LED lighting device or LED lamp also being located in the space, and (b) configured to:
    - determine whether the LED lighting device or LED lamp is in a sensor adjustment mode or in a non-adjustment mode,
    - when the LED lighting device or LED lamp is in the non-adjustment mode, not adjust the operation of the plurality of first LED packages and the plurality of second LED packages in response to receiving a sensor signal from the sensor, and
    - when the LED lighting device or lamp is in the sensor adjustment mode, (i) receive a sensor signal from the sensor, (ii) process the sensor signal, (iii) determine an adjustment to the operating light qualities of the LED lighting device or LED lamp based on the processing of the sensor signal and one or more goal

light qualities corresponding to the space, and (iv) adjust the operation of the plurality of first LED packages and the plurality of second LED packages in accordance with the determined adjustment such that a combination of (a) light emitted by the plurality of first LED packages and the plurality of second LED packages and (b) ambient light in the space provides lighting in accordance with the goal light qualities, wherein the adjustment comprises modifying (a) a number of the plurality of first LED packages in the first group, or (b) a number of the plurality of second LED packages in the second group to adjust one or more light qualities of light emitted by the LED lighting device or LED lamp.

2. The LED lighting device or LED lamp of claim 1, wherein the control unit is configured to receive an indication of user input from a remote switch, the user input selecting the one or more goal light qualities.
3. The LED lighting device or LED lamp of claim 2, wherein the remote switch is part of a building control system.
4. The LED lighting device or LED lamp of claim 1, wherein the one or more goal light qualities comprises at least one of a goal brightness, a goal color temperature, or a goal color rendering index (CRI).
5. The LED lighting device or LED lamp of claim 1, wherein the sensor signal indicates an ambient level of light and the adjustment comprises adjusting the brightness of the light emitted by the plurality of first LED packages and/or plurality of second LED packages.
6. The LED lighting device or LED lamp of claim 1 wherein the control unit is configured to operate the LED lighting device or LED lamp in accordance with a user-selected operating mode of a plurality of operating modes, the plurality of operating modes comprising at least one non-adjustment mode and at least one sensor adjustment mode,
  - when the control unit operates the LED lighting device or LED lamp in a non-adjustment mode, (a) the plurality of first LED packages and the plurality of second LED packages are operated in accordance with predefined operating light qualities and (b) responsive to receiving and processing the sensor signal, the plurality of first LED packages and the plurality of second LED packages continue to be operated in accordance with the predefined operating light qualities, and
  - when the control unit operates the LED lighting device or LED lamp in a sensor adjustment mode, responsive to receiving and processing the sensor signal, operation of the plurality of first LED packages and the plurality of second LED packages is adjusted in accordance with the adjustment such that at least one light quality in the space is in accordance with the one or more goal light qualities.
7. The LED lighting device or LED lamp of claim 1, wherein the LED lighting device or LED lamp is in wired or wireless communication with one or more second LED lighting devices or LED lamps and, responsive to determining the adjustment to the operating light qualities, the control unit communicates the adjustment to at least one of the one or more second LED lighting devices or LED lamps and the operation of the one or more second LED lighting devices or LED lamps is adjusted in accordance with the adjustment.
8. The LED lighting device or LED lamp of claim 1, wherein the LED lighting device or LED lamp comprises the one or more sensors.

35

9. An LED lighting device or LED lamp comprising:  
 a plurality of first LED packages each configured to emit  
 light having a first configurable light quality;  
 a plurality of second LED packages each configured to  
 emit light having a second configurable light quality; 5  
 at least one driver circuit configured to condition an  
 electrical current provided to at least one of (a) a first  
 group of the plurality of first LED packages or (b) a  
 second group of the plurality of second LED packages;  
 a switch comprising at least two selectable positions, at  
 least one selectable position corresponding to a set  
 operating mode and one selectable position corre-  
 sponding to a configurable operating mode; and  
 a switch control unit configured to operate the first group  
 of the plurality of first LED packages, via the at least  
 one driver circuit, and the second group of the plurality  
 of second LED packages, via the at least one driver  
 circuit, the first group of the plurality of first LED  
 packages and the second group of the plurality of  
 second LED packages operated independently of one  
 another, the switch control unit being: (a) in commu-  
 nication with a sensor located in the space and (b)  
 configured to:  
 determine whether the LED lighting device or LED  
 lamp is in a sensor adjustment mode or in a non-  
 adjustment mode, 25  
 when the LED lighting device or LED lamp is in the  
 non-adjustment mode, not adjust the operation of the  
 plurality of first LED packages and the plurality of  
 second LED packages in response to receiving a  
 sensor signal from the sensor, and 30  
 when the LED lighting device or lamp is in the sensor  
 adjustment mode, (i) receive a sensor signal from the  
 sensor, (ii) process the sensor signal, (iii) determine  
 an adjustment to the operating light qualities of the  
 LED lighting device or LED lamp based on the  
 processing of the sensor signal and one or more goal  
 light qualities corresponding to the space, and (iv)  
 adjust the operation of the plurality of first LED  
 packages and the plurality of second LED packages  
 in accordance with the determined adjustment such  
 that a combination of (a) light emitted by the plu-  
 rality of first LED packages and the plurality of  
 second LED packages and (b) ambient light in the  
 space provides lighting in accordance with the goal  
 light qualities, wherein the adjustment comprises  
 modifying (a) a number of the plurality of first LED  
 packages in the first group, or (b) a number of the  
 plurality of second LED packages in the second  
 group to adjust one or more light qualities of light  
 emitted by the LED lighting device or LED lamp, 50  
 and  
 wherein:  
 when the switch is in the selectable position corre-  
 sponding to the set operating mode, (a) the plurality  
 of first LED packages and the plurality of second  
 LED packages are operated in accordance with pre-  
 defined goal light qualities corresponding to the set  
 operating mode and (b) responsive to receiving an  
 indication of user input for selecting user-selected  
 goal light qualities, the plurality of first LED pack-  
 ages and the plurality of second LED packages  
 continue to be operated in accordance with the  
 predefined goal light qualities corresponding to the  
 set operating mode, and 65  
 when the switch is in the selectable position corre-  
 sponding to the configurable operating mode,

36

responsive to receiving an indication of user input  
 for selecting user-selected goal light qualities, opera-  
 tion of the plurality of first LED packages and the  
 plurality of second LED packages is modified in  
 accordance with the user-selected goal light quali-  
 ties.

10. The LED lighting device or LED lamp of claim 9,  
 wherein the one or more goal light qualities comprises  
 at least one of a goal brightness, a goal color tempera-  
 ture, or a goal color rendering index (CRI).

11. The LED lighting device or LED lamp of claim 9,  
 wherein the sensor signal indicates an ambient level of light  
 and the adjustment comprises adjusting the brightness of the  
 light emitted by the plurality of first LED packages and the  
 plurality of second LED packages.

12. An LED lighting device or LED lamp comprising:  
 a plurality of first LED packages each configured to emit  
 light having a first configurable light quality;  
 a plurality of second LED packages each configured to  
 emit light having a second configurable light quality;  
 at least one driver circuit configured to condition an  
 electrical current provided to at least one of (a) a first  
 group of the plurality of first LED packages or (b) a  
 second number of the plurality of second LED pack-  
 ages;  
 a switch comprising at least two selectable positions, at  
 least one selectable position corresponding to a non-  
 adjustment mode and at least one selectable position  
 corresponding to a sensor adjustment mode; and  
 a switch control unit configured to operate the first group  
 of the plurality of first LED packages, via the at least  
 one driver circuit, and the second group of the plurality  
 of second packages, via the at least one driver circuit,  
 the first group of the plurality of first LED packages and  
 the second group of the plurality of second LED  
 packages operated independently of one another, the  
 switch control unit being: (a) in communication with a  
 sensor located in a space, the LED lighting device or  
 LED lamp also being located in the space, and (b)  
 configured to:

determine, based on the switch, whether the LED  
 lighting device or LED lamp is in a sensor adjust-  
 ment mode or in a non-adjustment mode,  
 when the LED lighting device or LED lamp is in the  
 non-adjustment mode, not adjust the operation of the  
 plurality of first LED packages and the plurality of  
 second LED packages in response to receiving a  
 sensor signal from the sensor, and  
 when the LED lighting device or lamp is in the sensor  
 adjustment mode, (i) receive a sensor signal from the  
 sensor, (ii) process the sensor signal, (iii) determine  
 an adjustment to the operating light qualities of the  
 LED lighting device or LED lamp based on the  
 processing of the sensor signal and one or more goal  
 light qualities corresponding to the space, and (iv)  
 adjust the operation of the plurality of first LED  
 packages and the plurality of second LED packages  
 in accordance with the determined adjustment such  
 that a combination of (a) light emitted by the plu-  
 rality of first LED packages and the plurality of  
 second LED packages and (b) ambient light in the  
 space provides lighting in accordance with the goal  
 light qualities, wherein the adjustment comprises  
 modifying (a) a number of the plurality of first LED  
 packages in the first configurable group, or (b) a  
 number of the plurality of second LED packages in

the second configurable group to adjust one or more light qualities of light emitted by the LED lighting device or LED lamp.

**13.** The LED lighting device or LED lamp of claim **12**, wherein the switch control unit is configured to receive an indication of user input from a remote switch, the user input selecting the one or more goal light qualities. 5

**14.** The LED lighting device or LED lamp of claim **13**, wherein the remote switch is part of a building control system. 10

**15.** The LED lighting device or LED lamp of claim **12**, wherein the non-adjustment mode is a configurable operating mode and the sensor adjustment mode is a set operating mode.

**16.** The LED lighting device or LED lamp of claim **12**, wherein the at least one non-adjustment mode comprises a set operating mode and a configurable operating mode. 15

**17.** The LED lighting device or LED lamp of claim **12**, wherein the at least one sensor adjustment mode comprises a set operating mode and a configurable operating mode. 20

**18.** The LED lighting device or LED lamp of claim **12**, wherein the sensor is at least one of a light sensor or a motion sensor.

**19.** The LED lighting device or LED lamp of claim **12**, wherein the one or more goal light qualities comprises at least one of a goal brightness, a goal color temperature, or a goal color rendering index (CRI). 25

**20.** The LED lighting device or LED lamp of claim **12**, wherein the sensor signal indicates an ambient level of light and the adjustment comprises adjusting the brightness of the light emitted by the plurality of first LED packages and/or the plurality of second LED packages. 30

\* \* \* \* \*