

Dec. 5, 1939.

S. TARZIAN

2,181,982

VARIABLE HIGH FREQUENCY TRANSFORMER

Filed May 31, 1938

2 Sheets-Sheet 1

FIG. 1.

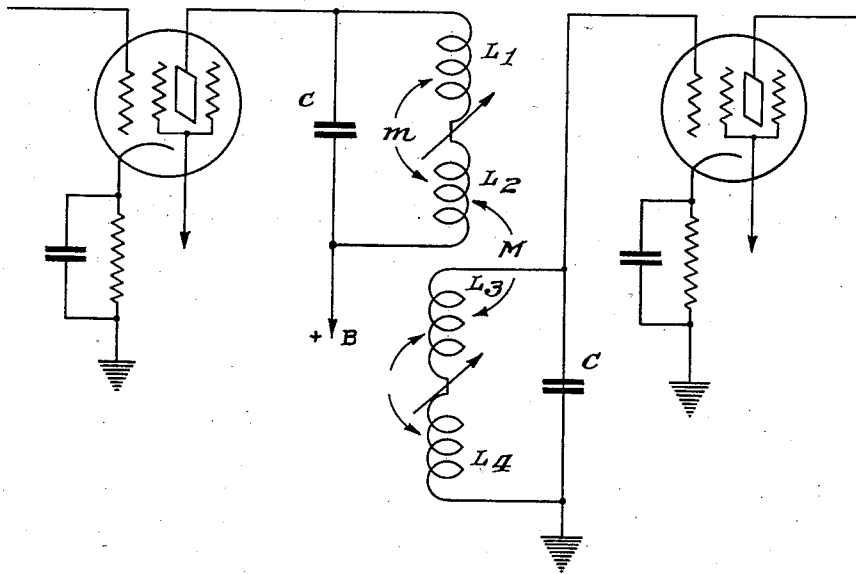
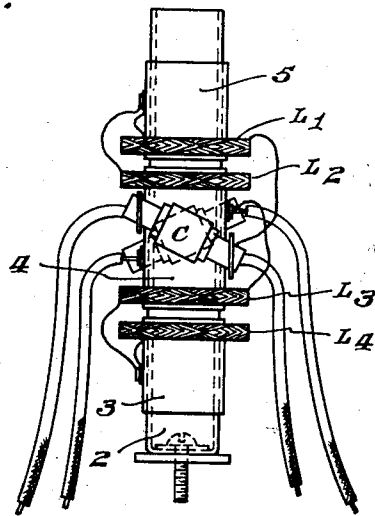

FIG. 2.



Inventor
Sarkes Tarzian

BY

J. J. Huff

Attorney

Dec. 5, 1939.

S. TARZIAN

2,181,982

VARIABLE HIGH FREQUENCY TRANSFORMER

Filed May 31, 1938

2 Sheets-Sheet 2

FIG. 3.

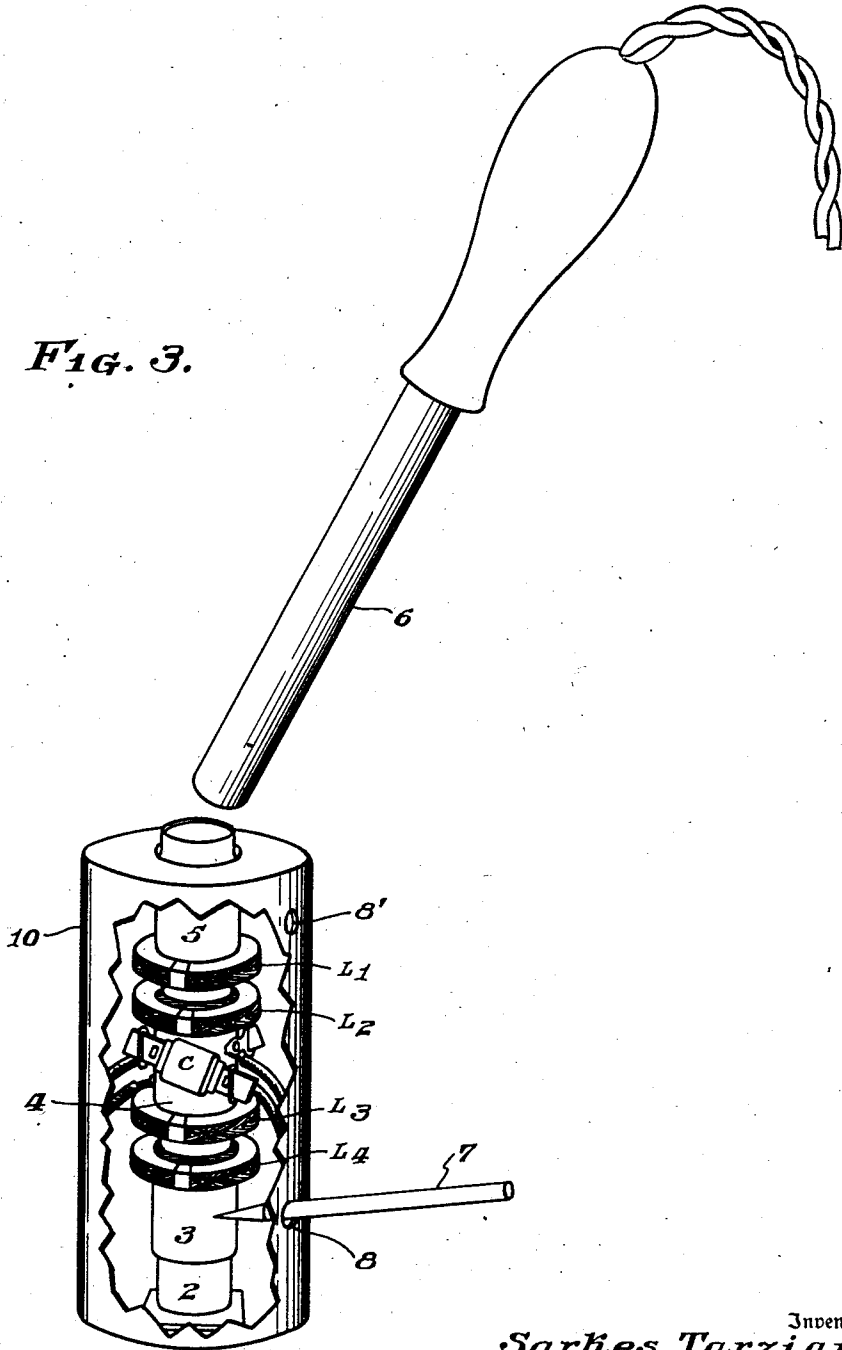

Inventor
Sarkes Tarzian

By

J. J. Huff

Attorney

UNITED STATES PATENT OFFICE

2,181,982

VARIABLE HIGH FREQUENCY TRANSFORMER

Sarkes Tarzian, Buenos Aires, Argentina, assignor to Radio Corporation of America, a corporation of Delaware

Application May 31, 1938, Serial No. 210,982
In Argentina November 12, 1937

4 Claims. (Cl. 171—119)

This invention relates to improvements in intermediate frequency transformers for variable inductance tuning in a superheterodyne radio receiver, and has for its main object the elimination of the disadvantages known in the usual transformers.

In less expensive radio receivers, intermediate frequency transformers are usually tuned by means of a variable condenser of the mica type. This result is obtained by means of an adjusting screw which increases or reduces the pressure applied on the metal sheets forming the condenser element. The mica is placed between the sheets to act as a dielectric. This mica condenser varies in capacity from around 50 to 120 mmfd. The inductance associated with the tuned circuit has a fixed value.

Due to the nature of the mica variable condenser, the capacity thereof, and therefore the tuning of the intermediate frequency transformer, changes with mechanical jerks and vibrations, as well as changes in temperature and humidity.

The mechanical jerks alter the setting of the adjusting screw, which in turn increases or reduces the capacity of the condenser. The changes in temperature cause the expansion and contraction of the elements forming the mica variable condenser, with a resulting change in capacity.

In the case of humidity the action is different. The air charged with humidity may actually deposit small particles of water between the condenser sheets and thus change the dielectric constant of the dielectric material. Under conditions of high humidity, the increase in capacity due to humidity may be as high as 15 per cent. This means a change of up to $7\frac{1}{2}$ per cent. in the frequency at which the intermediate frequency transformer is tuned. If the resonance frequency is 390 kc., then the change reaches to around 30 kc. Changes of this order not only alter the reading of the dial of a radio receiver but also mean a loss in sensibility and selectivity due to misalignment.

According to the present invention, a fixed impregnated mica condenser is used which, due to its construction and processing, is not subject to the limitations outlined above for the variable mica type, and the tuning is effected by adjusting the inductance, which is variable. In this type of intermediate frequency transformer, all the disadvantages associated with the common type of mica variable condenser are obviated. The construction and treatment are such that the variable inductance units cannot change with me-

chanical vibrations or normal changes in temperature and/or humidity. The usual intermediate frequency transformer consists of two tuned circuits which are coupled together by inductive or capacitive coupling, or both. In the type according to the present invention, the inductance associated with the tuned circuit is formed of two or more parts. The inductance value of the two or more coils in series is adjusted by varying the space between the sections. This varies the mutual inductance between the sections, and therefore the inductance associated with the tuned circuit.

In order that the invention may be more carefully understood and readily carried into practice, the same has been illustrated in a preferred embodiment in the accompanying drawings, wherein

Figure 1 is a circuit diagram of an intermediate frequency transformer according to the present invention,

Figure 2 is a perspective view of the intermediate frequency transformer made in accordance with my invention, and

Figure 3 shows a physical arrangement indicating the method used in the construction of this type of intermediate frequency transformer.

Referring to Fig. 1, L1 and L2 are the sections of the transformer primary, shown in two halves, m indicating the mutual inductance between said two halves. This m is variable, and is adjusted to the correct value so as to tune the circuit L1 and L2 and C to resonance. The inductance value associated with the tuned circuit is equal to $L1 + L2 + 2m$. The mutual between the two tuned circuits, primary and secondary, respectively, is indicated by M. This value is fixed and only varies slightly with the variation of m . M is designed to give the required selectivity and gain. L2 and L3 are wound on a paper tube or sleeve 4, with a fixed defined distance between both. This distance determines the mutual M between the two tuned circuits. The condensers C are also placed in position on this same paper sleeve in this particular construction. L1 is wound on paper tube or sleeve 5, and L4 on paper tube or sleeve 3. These three winding units 3, 4 and 5 are supported by a paper tube 2. The diameters of tube 2, and sleeves 3, 4 and 5 are such that sleeves 3 and 5 easily move on the tubular support 2 when no thermo-plastic impregnating compound is present in these tubes or when such compound is heated to a point where it becomes plastic or in fluid condition. The diameter of the sleeve 4 is such that it cannot move very easily

on the tube 2 under the conditions indicated above for the sleeves 3 and 5. After assembling the various parts forming the complete intermediate frequency transformer as illustrated in Fig. 2, the entire unit is submerged in an impregnating compound. This will remove all the humidity, etc., from the coils and paper tubes. When the intermediate frequency transformer is withdrawn from the impregnating tank, a sufficient impregnating compound should be left on the coils and paper tubes to seal them against humidity and also to render it impossible, when the impregnating compound has been cooled down to room temperature, to move the coil L1 with respect to L2, and the coil L3 with respect to L4.

Fig. 3 illustrates an intermediate frequency transformer within its housing 10, which also serves as an electric shield, adapted to be mounted on a radio chassis. To tune the intermediate frequency transformer to resonance it is desirable to proceed in the following manner:

(a) A heating device 6 is inserted into the open end of support tube 2 through an aligned end opening in the housing 10 and the upper portion of the intermediate frequency transformer.

(b) When the thermo-plastic impregnating compound has reached a semi-fluid condition, the heating device is withdrawn.

(c) A pointed adjusting tool 7 is inserted through an adjusting orifice 8 at the side of the housing adjacent the sleeve 3 for the coil section L4 and a direct contact with sleeve 3 is made. Then the position of coil section L4 with respect to section L3 is adjusted to resonance.

(d) The same procedure as in (c) is followed to adjust L1 with respect to L2, introducing the tool 7 through the orifice 8'.

(e) After a few seconds, the impregnating compound will have solidified and mechanical jerks or normal changes in temperature or humidity will not alter the setting of L1 and L4 relative to L2 and L3, respectively.

I claim as my invention:

1. In a high frequency transformer, a tubular coil support, a plurality of inductance coil sections axially positioned along said support in concentric relation therewith, thermo-plastic means securing one of said sections on said support in spaced relation to another of said sections, a housing surrounding said support and forming therewith an enclosure for said coils,

said support and said housing having aligned openings at one end, respectively, for the application of heat within said tubular support to soften said thermo-plastic means, and an orifice in said housing provided adjacent said one section for the insertion of a tool to adjust the relative position of said one of said coil sections along said support.

2. In a tuned intermediate frequency transformer, a tubular coil support, primary and secondary inductance coils axially arranged on said support and including a plurality of spaced coil sections respectively, a second tubular support concentrically arranged along said first named support for supporting the adjacent sections of said primary and secondary coil structure, respectively, in fixed coupling relation independently of the other of said coil sections, thermo-plastic means for securing more remote sections of said primary and secondary coils, respectively, to said first named tubular support, and means for locally applying heat to the inner surface of said first named tubular support for softening said thermo-plastic means whereby at least one of said more remote sections may be relatively adjusted along said first named support to adjust the self-inductance of the corresponding coil.

3. In a tuned intermediate frequency transformer, a tubular coil support, primary and secondary inductance coil sections axially arranged along said support in spaced relation, a sleeve on said support carrying the adjacent coil sections of said primary and secondary, respectively, in fixed coupling relation, means including other sleeves and thermo-plastic material for securing more remote sections of said primary and secondary coils, respectively, to said first named tubular support, and means for locally applying heat within said tubular support for softening said thermo-plastic means whereby at least one of said more remote sections may be moved along said first named support to vary the self-inductance of the corresponding coil.

4. The invention as set forth in claim 3 wherein a shield housing surrounds said transformer and is provided with an orifice adjacent one of said other sleeves for the insertion of an adjusting means to move said remote section.

SARKES TARZIAN.