



Europäisches Patentamt
European Patent Office
Office européen des brevets



(11) **EP 1 105 687 B1**

(12) **EUROPEAN PATENT SPECIFICATION**

(45) Date of publication and mention
of the grant of the patent:

05.11.2003 Bulletin 2003/45

(21) Application number: **99940387.6**

(22) Date of filing: **23.08.1999**

(51) Int Cl.7: **F24F 11/00**

(86) International application number:
PCT/GB99/02766

(87) International publication number:
WO 00/011410 (02.03.2000 Gazette 2000/09)

(54) **VENTILATING SYSTEM**

LÜFTUNGSSYSTEM

INSTALLATION DE VENTILATION

(84) Designated Contracting States:
**AT BE CH CY DE DK ES FI FR GB GR IE IT LI LU
MC NL PT SE**

(30) Priority: **22.08.1998 GB 9818305**

(43) Date of publication of application:
13.06.2001 Bulletin 2001/24

(73) Proprietor: **NuAire Limited**
Caerphilly Mid Glamorgan CF8 1XH (GB)

(72) Inventors:
• **FUSSELL, Michael**
Newport Gwent NP1 8SP (GB)

• **BRADLEY, John**
Morganstown Cardiff CF4 8FA (GB)

(74) Representative: **Gibson, Stewart Harry**
URQUHART-DYKES & LORD,
Three Trinity Court,
21-27 Newport Road
Cardiff CF24 0AA (GB)

(56) References cited:
EP-A- 0 851 179 **WO-A-96/05473**
WO-A-96/10733 **US-A- 4 312 226**
US-A- 4 986 469 **US-A- 5 718 627**

EP 1 105 687 B1

Note: Within nine months from the publication of the mention of the grant of the European patent, any person may give notice to the European Patent Office of opposition to the European patent granted. Notice of opposition shall be filed in a written reasoned statement. It shall not be deemed to have been filed until the opposition fee has been paid. (Art. 99(1) European Patent Convention).

Description

[0001] This invention relates to a system for ventilating dwellings and other buildings.

[0002] It is known to provide a dwelling with a ventilation system which comprises a fan mounted in the loft or roof space of the building and arranged to discharge air into the accommodation or living space of the building. This places the living space under a slight positive pressure, which forces air to flow out of the building through gaps in windows, doors etc: the effect is that the living space is subjected continuously to a ventilating flow of air, which acts to remove or prevent the build up of condensation and also to remove or prevent the possible build up of radon gas. Such ventilating systems are often installed in dwellings to overcome the tendency in some buildings for damp conditions to develop or possibly radon gas to accumulate. Typically the ventilating system draws in its air from within the roof space of the dwelling, but this air may be cold in winter and hot in summer and (in both these cases) it is undesirable to draw this air into the living space of the building.

[0003] US-A-4 312 226 shows a ventilating system wherein control means select the source of the air to be drawn into an accommodation space: either from a single outdoor source or by recirculating air from the accommodation space.

[0004] We have now devised a ventilating system which avoids or alleviates the problem of delivering air into the dwelling which is inappropriately cold in winter or inappropriately warm in summer.

[0005] In accordance with the present invention, there is provided a ventilating system according to claim 1.

[0006] Preferably the control means controls the fan means in accordance with the difference between the sensor in the accommodation space and at least one of the other sensors (preferably a sensor in the loft space), at least in the event that this temperature difference exceeds a predetermined amount, in order to reduce the temperature difference.

[0007] In particular, the system may be arranged to draw in the warmest available air in the winter. It is known that the effect of the sun's rays on the roof tiles is to create a layer of warm air adjacent the tiles: an enclosed space may be formed under the roof tiles on the most southerly-facing side of the building, to provide a location from which the ventilating system may draw its air; alternatively, an enclosed space may be provided over the surface of the roof tiles. The roof space itself may form another location from which the system is able to draw its air. When the solar-heated air in the enclosed space is of a higher sensed temperature than the roof space, then the ventilating system draws its air from this enclosed space. If the temperature of the warmest available air is greater, by more than a predetermined amount, than the temperature within the accommodation space of the building, preferably the control means causes the fan means to run at a higher-than-normal

speed in order to increase the flow rate. However, if the warmest available air is above a predetermined maximum temperature, then the system draws in air from the next warmest inlet, or a mixture of air from different inlets, or the fan is reduced in speed or even switched off altogether. Also, if the warmest available air falls below a predetermined minimum temperature, the fan is reduced in speed or switched off.

[0008] Preferably, for use in summer, the ventilating system is able to draw in air from the exterior of the building, preferably on the most northerly-facing side of the building, for example under the eaves. The system is then arranged to draw in air from the exterior of the building, or from within the roof space, or possibly from the solar-heated enclosed space. Especially at night, the air in the roof space or solar-heated enclosed space can be considerably cooler than the air within the accommodation space of the building. If the coolest available air is cooler, by more than a predetermined amount, than the air within the building, preferably the speed of the fan means is increased. If the coolest available air is below a predetermined temperature, then air is drawn in from the next coolest inlet or a mixture of air from different inlets is drawn in, or the fan may be reduced in speed or even switched off altogether.

[0009] Preferably the control means has a first operating mode for use in winter and a second operating mode for use in summer. A manual selector may be provided for selecting the operating mode. Instead, the control means may include a timer for automatically changing the operating mode at appropriate times of the year. As another option, the control means may be arranged to monitor the temperature indicated by one or more of the temperature sensors over a period of time, to determine when to make a change of operating mode: in particular, the control means may respond to the temperature of the air being delivered into the accommodation space.

[0010] Preferably a solar cell or thermoelectric cell is provided, to generate electrical power from the sun's rays. The ventilating system may be powered from this cell, or from a battery charged by the cell, when sufficient power is available in this way: at other times, the system is powered from the mains. When the fan means is required to run at its higher speed, the additional power is preferably drawn from the solar or thermoelectric cell, or from the battery charged from this cell.

[0011] The ventilating system may comprise a second fan means for withdrawing air from within the accommodation space of the building and expelling it to the exterior of the building. In this case, preferably a heat exchanger is provided for transferring heat between the air being expelled from, and the air being delivered into, the accommodation space. Accordingly, in cold weather conditions, warm air being expelled, e.g. from a kitchen or bathroom or living room, may be used to pre-warm the incoming air: alternatively, in warm weather conditions, the air being expelled may be used to cool the

incoming air. Preferably the control means is arranged to stop or reduce the speed of the second fan means, or to bypass the heat exchanger, in the event of the temperature of the expelled air being lower than the incoming air, in cold weather conditions, or higher than the incoming air, in warm weather conditions.

[0012] The ventilating system may comprise a heat storage means coupled to a duct for incoming air and arranged to store heat from incoming warm air during daytime and return heat to the incoming air during night time.

[0013] Embodiments of this invention will now be described by way of examples only and with reference to the accompanying drawings, in which:

FIGURE 1 is a schematic section through a dwelling incorporating a ventilating system in accordance with this invention; and

FIGURE 2 is a similar sectional view, showing various modifications applicable to the system shown in Figure 1.

[0014] Referring to the drawing, there is shown a conventional house comprising a tiled apex roof 10, a roof space 11 formed under the roof and above the upstairs ceiling 12 of the house, and a main accommodation space 13, which comprises a plurality of rooms including living, reception and bedrooms.

[0015] A ventilating unit 14 is mounted in the roof space 11 and has a plurality of inlet ducts 15, 16, 17 connected to it, with flaps or shutters provided in the ventilating unit 14 for selectively opening and closing the corresponding ends of the inlet ducts 15, 16, 17. An outlet duct 18 extends from the ventilating unit 14 through the ceiling 12 to a diffuser 19 mounted to the ceiling, for example in the landing of the house. The ventilating unit 14 includes a fan (not shown) driven by an electric motor.

[0016] The first inlet duct 15 extends between the ventilating unit 14 and a point located within the roof or loft space 11. The second inlet duct 16 extends between the ventilating unit 14 and an enclosed space 20 which is formed in the roof space 11 under the tiles or roof covering of the most southerly-facing side of the roof. This enclosed space 20 may be formed as a partition 22 fitted to extend parallel to the tiled surface of the roof and between adjacent roof trusses: air is able to enter the enclosed space 20, from the exterior, through vents provided in the roof or through the gaps between tiles.

[0017] The third inlet duct 17 extends between the ventilating unit 14 and a point located externally of the house, preferably on the most northerly-facing side of the house and conveniently under the eaves.

[0018] A temperature sensor T_1 , T_2 , T_3 is disposed adjacent the inlet to each inlet duct 15, 16, 17, the temperature sensors being connected by respective cables to a controller of the ventilating unit 14. The ventilating unit 14 is also connected via respective cables to a tem-

perature sensor T_o and switch S, which are mounted inside the accommodation space 13 of the house.

[0019] The switch S comprises a selector which is operable between winter and summer settings. In the winter setting of this selector, the ventilating unit 14 drives its fan to draw air, normally at a low flow rate, along one of the ducts 15, 16 or 17, depending on which one will provide the warmest air (as determined by the sensors T_1 , T_2 and T_3): the flaps or shutters of the ventilating unit close off the remaining inlet ducts. This flow of air is delivered through the outlet duct 18 and into the accommodation space of the house, via the diffuser 19 on the ceiling 12, with the effect of maintaining a slight positive air pressure inside the house: air is forced to flow out of the house through gaps in the doors or windows etc. so that the house is subjected to a slight positive pressure and a continuous ventilating flow of air, which acts to remove or prevent the build up of condensation and also acts to remove or prevent the possible build up of radon gas. Air is always drawn from the warmest point and thus no significant heat loss should occur. However, the fan flow rate is preferably reduced or the fan switched off if the incoming-air temperatures indicated by sensors T_1 , T_2 and T_3 are below a predetermined minimum level, in order to prevent very cold air from being drawn into the house.

[0020] When the temperature sensed inside the house, by sensor T_o , is substantially below the temperature sensed by any of the sensors T_1 , T_2 or T_3 , the ventilating unit 14 increases the speed of its fan and draws air from the inlet duct 15, 16 or 17 which has the warmest air as its inlet. Typically, the warmest air will be in the enclosed space 20 under the most southerly-facing side of the roof 10. Thus, it will be appreciated that air, which is warmer than the air inside the accommodation space 13 of the house, is drawn from the roof space 11 through either the first, second or third inlet ducts 15, 16 or 17 and supplied by the ventilating unit to raise the temperature inside the accommodation space 13 of the house.

[0021] The ventilating unit 14 draws power from mains supply. However, preferably a solar cell 28 is mounted to the exterior of the most southerly-facing side of the roof 10: the ventilating unit may be arranged to draw its power from the solar cell 28 or from a battery charged by the solar cell 28, instead of from the mains supply, when the output of the solar cell is sufficient. Also, the additional power that is required when the fan speeds up is preferably provided by the solar cell 28 or by the battery charged by the solar cell.

[0022] When the selector of switch S is set to its summer setting, the fan normally operates at a slow speed to provide a flow of air into the house, as hereinbefore described. The air is preferably drawn from whichever of inlet ducts 15, 16, 17 has the coolest air at its inlet, provided that this air is not too cold (in which case air is drawn from the next coolest inlet or a mixture is drawn from various inlets, or the fan is stopped altogether).

[0023] If the temperature sensed inside the house, by sensor T_0 , is substantially above the temperature being sensed by one of the sensors T_1 , T_2 , T_3 , the ventilating unit 14 increases the speed of its fan and draws air from the duct 15, 16, 17 which has the coolest air at its inlet.

[0024] Sometimes the air inside the roof space 11 is not at such a low temperature as the exterior air, especially the exterior air immediately adjacent the most northerly-facing side of the roof. Thus, the inlet duct 17 may be used to draw air from this point on hot days.

[0025] Thus, it will be appreciated that air, which is cooler than the air inside the main accommodation space 13 of the house, is drawn by the ventilating unit through a selected inlet duct 15, 16, 17 and passed into the accommodation space of the house, in order to provide cooling in the summer. Again, the power for the fan is provided by the solar cell 28 or by the rechargeable battery when the output of the solar cell or its battery is sufficient: also, the additional power required, when increased fan speed is demanded, may be provided from the solar cell or the battery charged by it.

[0026] In one modification, and as shown in Figure 2, a solar heater 20' is installed on the south-facing side of the roof, instead of the enclosed space 20 being formed under the roof covering. The solar heater 20' comprises a planar enclosure to which the inlet end of the duct 16 is connected, the enclosure having vents or openings for the inlet of replacement air from the exterior. The air within the enclosure is heated by the solar radiation.

[0027] In another modification, also shown in Figure 2, the ventilating unit 14 includes a fan for withdrawing air from the living space of the building, via a duct 24, and expelling the withdrawn air to the exterior via a duct 26. The unit 14 includes a heat exchanger 14a, for exchanging heat between the air being expelled and the air being drawn through one of the inlet ducts and delivered into the living space via the air delivery duct 18. When the winter mode is selected by the selector switch S, then if the air being expelled is warmer than the incoming air, the heat exchanger 14a serves to enhance the temperature of the incoming air. Similarly when summer mode is selected, then if the air being expelled is cooler than the incoming air, the heat exchanger serves to reduce the temperature of the incoming air. In winter, if the temperature of the expelled air (as sensed by a sensor T_4) is lower than the incoming air, then the extractor fan is stopped or reduced in speed, or the heat exchanger is bypassed. In summer, if the temperature of the expelled air is higher than the incoming air, then again the extractor fan is stopped or reduced in speed, or the heat exchanger is bypassed.

[0028] In a further modification shown in Figure 2, a heat store 30 is provided and coupled to one of the inlet ducts (preferably the duct 16 from the solar heating panel 20' on the roof surface or the enclosure 20 under the roof surface). the heat store 30 may comprise a tank of water and serves to store heat from the incoming warm air during the day, then transfer this heat back to the

incoming cool air at night. Where the heat store 30 is a water tank, then this may be used as a supply of hot water. The water tank may be provided with an electric immersion heater for using electricity at low cost overnight to heat the water.

[0029] Whilst the ventilating system which has been described has a switch for selecting winter or summer modes of operation, the switch may be arranged to select an "automatic" mode. In this case, a temperature sensor T_5 is provided, e.g. in the unit 14 or the outlet duct 18, to sense the temperature of the air being delivered into the living space. Then, if the temperature of the air being delivered is below a threshold value, the controller of the ventilating system determines which source is able to provide the warmest air, and selects the corresponding inlet duct 15, 16 or 17. If instead the temperature of the delivered air is above the threshold value, the controller determines which source is able to provide the coolest air, and selects the corresponding inlet duct 15, 16 or 17. Preferably the threshold temperature is manually selectable via the switch S. In a further modification, the system may simply run at all times in automatic mode, and not have the facility for selecting winter or summer modes. In the automatic mode, preferably the controller is arranged to reduce the speed of or to stop the air delivery fan if the temperature of the available air, sensed at T_1 , T_2 and T_3 , is excessively cold (when warm air is demanded) or excessively warm (when cool air is demanded: further, the fan speed is preferably increased if the interior temperature (sensed at T_0) is substantially lower than the available inlet air (when warm air is demanded) or substantially higher than the available inlet air (when cool air is demanded).

[0030] It will be appreciated that the above-described ventilating systems act to deliver warm air (and not cold air) into the building during winter or cold weather conditions, and act to deliver cool air (and not warm air) into the building during summer or warm weather conditions.

Claims

1. A ventilating system installed in a building, the system comprising a ventilating unit (14) which includes a fan and is arranged to draw air in from selected inlet locations, said inlet locations being exterior of the accommodation space (13) of the building, and deliver said air into said accommodation space (13) of the building, a plurality of temperature sensors (T_0 , T_1 , T_2 , T_3), one for each inlet location from which the ventilating unit (14) is arranged to draw air and one for said accommodation space (13) of the building, and control means responsive to said temperature sensors of said inlet locations to select the inlet location from which said ventilating unit (14) draws in air.
2. A ventilating system as claimed in claim 1, in which

said control means is arranged for selecting the inlet location with the warmest available air under cold weather conditions, and for selecting the inlet location with the coolest available air under warm weather conditions.

3. A ventilating system as claimed in claim 2, in which said control means is responsive to the temperature of air being delivered into said accommodation space of the building, to determine whether to select the warmest available air or the coolest available air.
4. A ventilating system as claimed in claim 2 or 3, comprising means for selecting a winter mode or a summer mode of operation.
5. A ventilating system as claimed in any preceding claim, in which said control means is arranged to control the flow rate of said fan in accordance with the difference in temperature between the accommodation space of the building and the temperature of the available inlet air, or in accordance with the available inlet air temperature.
6. A ventilating system as claimed in claim 5, in which said control means is arranged to stop said fan or reduce the flow rate of said fan in the event of the available inlet air temperature being below a minimum level or above a maximum level.
7. A ventilating system as claimed in claim 5 or 6, in which said control means is arranged to increase the flow rate of said fan, in cold weather conditions, in the event of the temperature of the accommodation space of the building being lower than the temperature of the available inlet air by greater than a predetermined amount.
8. A ventilating system as claimed in any one of claims 5 to 7, in which said control means is arranged to increase the flow rate of said fan, in warm weather conditions, in the event of the temperature of the accommodation space of the building being higher than the temperature of the available inlet air by greater than a predetermined amount.
9. A ventilating system as claimed in any preceding claim, in which one of the locations from which said ventilating unit is able to draw air comprises an enclosed space positioned on or under the roof covering and arranged for the enclosed volume of air to be heated by solar radiation.
10. A ventilating system as claimed in any preceding claim, in which one of the locations from which said ventilating unit is able to draw air is a location exterior to said building, where little or no solar radiation

is received.

11. A ventilating system as claimed in any preceding claim, further comprising second fan for withdrawing air from within said accommodation space of the building and expelling it to the exterior of the building.
12. A ventilating system as claimed in claim 11, further comprising a heat exchanger for transferring heat between the air being expelled from, and the air being delivered into, said accommodation space of the building.
13. A ventilating system as claimed in claim 12, in which said control means is arranged to stop or reduce the flow rate of said second fan, or to bypass said heat exchanger, in the event that the temperature of the expelled air is lower than the incoming air, in cold weather conditions, or higher than the incoming air, in warm weather conditions.
14. A ventilating system as claimed in any preceding claim, further comprising a heat storage means coupled to a duct for incoming air and arranged to store heat from incoming warm air during daytime and return heat to the incoming air during night time.

Patentansprüche

1. In einem Gebäude installiertes Lüftungssystem, umfassend eine Lüftungseinheit (14), die ein Gebläse aufweist und so angeordnet ist, um Luft von ausgewählten Einlaßstellen anzusaugen, wobei sich die Einlaßstellen außerhalb des Unterbringungsraums (13) des Gebäudes befinden, und die Luft in den Unterbringungsraum (13) des Gebäudes zuzuführen, eine Mehrzahl von Temperatursensoren (10, 11, 12, 13), und zwar einen für jede Einlaßstelle, aus der die Lüftungseinheit (14) zum Luft Ziehen eingerichtet ist, und einen für den Unterbringungsraum (13) des Gebäudes, und Steuermittel, die auf die Temperatursensoren an den Einlaßstellen ansprechen, um die Einlaßstellen auszuwählen, aus denen die Lüftungseinheit Luft ansaugt.
2. Lüftungssystem gemäß Anspruch 1, worin die Steuermittel ausgebildet sind zum Auswählen der Einlaßstelle mit der wärmsten verfügbaren Luft unter kalten Wetterbedingungen und zum Auswählen der Einlaßstelle mit der kältesten verfügbaren Luft unter warmen Wetterbedingungen.
3. Lüftungssystem gemäß Anspruch 2, worin die Steuermittel abhängig sind von der Temperatur der Luft, die dem Unterbringungsraum des Gebäudes zuge-

führt wird, um zu bestimmen, ob die wärmste verfügbare Luft oder die kühlschte verfügbare Luft ausgewählt wird.

4. Lüftungssystem gemäß Anspruch 2 oder 3, umfassend Mittel zum Auswählen eines Winter-Betriebsmodus oder eines Sommer-Betriebsmodus.
5. Lüftungssystem nach einem beliebigen der vorangehenden Ansprüche, worin die Steuermittel so ausgebildet sind, um die Durchflußmenge des Gebläses in Abhängigkeit von den Temperaturunterschied zwischen dem Unterbringungsraum des Gebäudes und der Temperatur der verfügbaren Einlaßluft oder in Abhängigkeit von der verfügbaren Einlaßlufttemperatur, zu steuern.
6. Lüftungssystem nach Anspruch 5, worin die Steuermittel so ausgebildet sind, daß Gebläse anzuhalten oder die Durchflußmenge des Gebläses zu verringern in dem Fall, wenn die Temperatur der verfügbaren Einlaßluft unter einem Mindestwert oder über einem Höchstwert liegt.
7. Lüftungssystem gemäß Anspruch 5 oder 6, worin die Steuermittel so ausgebildet sind, um die Durchflußmenge des Gebläses zu erhöhen, bei kalten Wetterbedingungen, in dem Fall, wenn die Temperatur des Unterbringungsraums des Gebäudes niedriger ist als die Temperatur der verfügbaren Einlaßluft um mehr als einen vorbestimmten Wert.
8. Lüftungssystem nach einem beliebigen der Ansprüche 5 bis 7, worin die Steuermittel so ausgebildet sind, um die Durchflußmenge des Gebläses zu erhöhen, bei warmen Wetterbedingungen, in dem Fall, wenn die Temperatur des Unterbringungsraums des Gebäudes höher ist als die Temperatur der verfügbaren Einlaßluft um einen vorbestimmten Wert.
9. Lüftungssystem nach einem beliebigen der vorangehenden Ansprüche, worin eine der Stellen, von denen die Lüftungseinheit Luft ziehen kann, einen umschlossenen Raum aufweist, der auf oder unter dem bedeckenden Dach angeordnet ist und dazu ausgebildet ist, daß das umschlossene Luftvolumen durch Sonnenstrahlung erwärmt wird.
10. Lüftungssystem nach einem beliebigen der vorangehenden Ansprüche, worin eine der Stellen, von denen die Lüftungseinheit Luft zieht, eine Stelle außerhalb des Gebäudes ist, an der keine oder nur geringe Sonnenstrahlung aufgenommen wird.
11. Lüftungssystem nach einem beliebigen der vorangehenden Ansprüche, ferner umfassend ein zweites Gebläse zum Absaugen von Luft aus dem Un-

terbringungsraum des Gebäudes und zum Abführen der Luft an die äußere Umgebung des Gebäudes.

- 5 12. Lüftungssystem gemäß Anspruch 11, weiter umfassend einen Wärmetauscher zum Übertragen von Wärme zwischen der dem Unterbringungsraum des Gebäudes abgeführten und der dorthin zugeführten Luft.
- 10 13. Lüftungssystem gemäß Anspruch 12, worin die Steuermittel dazu ausgebildet sind, die Durchflußmenge des zweiten Gebläses zu verringern oder zu stoppen, oder den Wärmetauscher zu umgehen, in dem Fall, wenn die Temperatur der abzuführenden Luft, bei kalten Wetterbedingungen, niedriger ist als die der hereinkommenden Luft, oder, bei warmen Wetterbedingungen, größer als die der hereinkommenden Luft ist.
- 15 14. Lüftungssystem nach einem beliebigen der vorangehenden Ansprüche, weiter umfassend Wärmespeichermittel, die mit einer Leitung für hereinkommende Luft verbunden sind und so ausgebildet sind, um Wärme aus der hereinkommenden warmen Luft während des Tages zu speichern und die Wärme an die hereinkommende Luft während der Nacht abzugeben.

Revendications

- 35 1. Système de ventilation installé dans un bâtiment, ce système comprenant un groupe de ventilation (14) qui comporte un ventilateur et qui est agencé pour aspirer de l'air depuis des emplacements d'admission sélectionnés, lesdits emplacements d'admission étant extérieurs à l'espace de logement (13) du bâtiment, et pour délivrer ledit air dans ledit espace de logement (13) du bâtiment, une pluralité de capteurs de température (T_0, T_1, T_2, T_3), un pour chaque emplacement d'admission, à partir duquel le groupe de ventilation (14) est agencé pour aspirer de l'air et un pour ledit espace de logement (13) du bâtiment, et un moyen de commande qui réagit auxdits capteurs de température desdits emplacements d'admission afin de sélectionner l'emplacement d'admission à partir duquel ledit groupe de ventilation (14) aspire de l'air.
- 40 2. Système de ventilation selon la revendication 1, dans lequel ledit moyen de commande est agencé pour sélectionner l'emplacement d'admission avec l'air disponible le plus chaud possible, dans des conditions de temps froid, et pour sélectionner l'emplacement d'admission avec l'air disponible le plus froid possible, dans des conditions de temps chaud.
- 45
- 50
- 55

3. Système de ventilation selon la revendication 2, dans lequel ledit moyen de commande réagit à la température de l'air délivré dans ledit espace de logement du bâtiment, afin de déterminer s'il doit sélectionner l'air disponible le plus chaud possible ou l'air disponible le plus froid possible. 5
4. Système de ventilation selon la revendication 2 ou 3, comprenant un moyen permettant de sélectionner un mode de fonctionnement hiver ou été. 10
5. Système de ventilation selon l'une quelconque des revendications précédentes, dans lequel ledit moyen de commande est agencé pour commander le débit dudit ventilateur en fonction de la différence de températures entre l'espace de logement du bâtiment et la température de l'air d'admission disponible, ou en fonction de la température de l'air d'admission disponible. 15
6. Système de ventilation selon la revendication 5, dans lequel ledit moyen de commande est agencé pour arrêter ledit ventilateur ou réduire le débit dudit ventilateur dans l'éventualité où la température de l'air d'admission disponible serait inférieure à un niveau minimum ou supérieure à un niveau maximum. 20
7. Système de ventilation selon l'une quelconque des revendications 5 ou 6, dans lequel ledit moyen de commande est agencé pour augmenter le débit dudit ventilateur, dans des conditions de temps froid, dans l'éventualité où la température de l'espace de logement du bâtiment serait inférieure à la température de l'air d'admission disponible d'une valeur supérieure à une valeur prédéterminée. 25
8. Système de ventilation selon l'une quelconque des revendications 5 à 7, dans lequel ledit moyen de commande est agencé pour augmenter le débit dudit ventilateur, dans des conditions de temps chaud, dans l'éventualité où la température de l'espace de logement du bâtiment serait supérieure à la température de l'air d'admission disponible d'une valeur supérieure à une valeur prédéterminée. 30
9. Système de ventilation selon l'une quelconque des revendications précédentes, dans lequel l'un des emplacements à partir duquel ledit groupe de ventilation peut aspirer de l'air comprend un espace confiné placé sur, ou sous la couverture du toit, et agencé pour que le volume d'air confiné soit chauffé par le rayonnement solaire. 35
10. Système de ventilation selon l'une quelconque des revendications précédentes, dans lequel l'un des emplacements à partir duquel ledit groupe de ventilation peut aspirer de l'air, est un emplacement extérieur audit bâtiment, qui reçoit peu ou pas de rayonnement solaire. 40
11. Système de ventilation selon l'une quelconque des revendications précédentes, comprenant en outre un second ventilateur permettant d'aspirer l'air situé à l'intérieur dudit espace de logement du bâtiment et de l'expulser vers l'extérieur du bâtiment. 45
12. Système de ventilation selon la revendication 11, comprenant en outre un échangeur de chaleur permettant de transférer la chaleur entre l'air expulsé de, et l'air délivré dans, ledit espace de logement du bâtiment. 50
13. Système de ventilation selon la revendication 12, dans lequel ledit moyen de commande est agencé pour arrêter ou réduire le débit dudit second ventilateur, ou pour dériver ledit échangeur de chaleur, dans l'éventualité où la température de l'air expulsé serait inférieure à l'air entrant, dans des conditions de temps froid, ou supérieure à l'air entrant, dans des conditions de temps chaud. 55
14. Système de ventilation selon l'une quelconque des revendications précédentes, comprenant en outre un moyen de stockage de chaleur associée à une conduite d'entrée d'air et agencé pour stocker la chaleur provenant de l'air chaud entrant pendant la journée et renvoyer la chaleur vers l'air entrant au cours de la nuit.

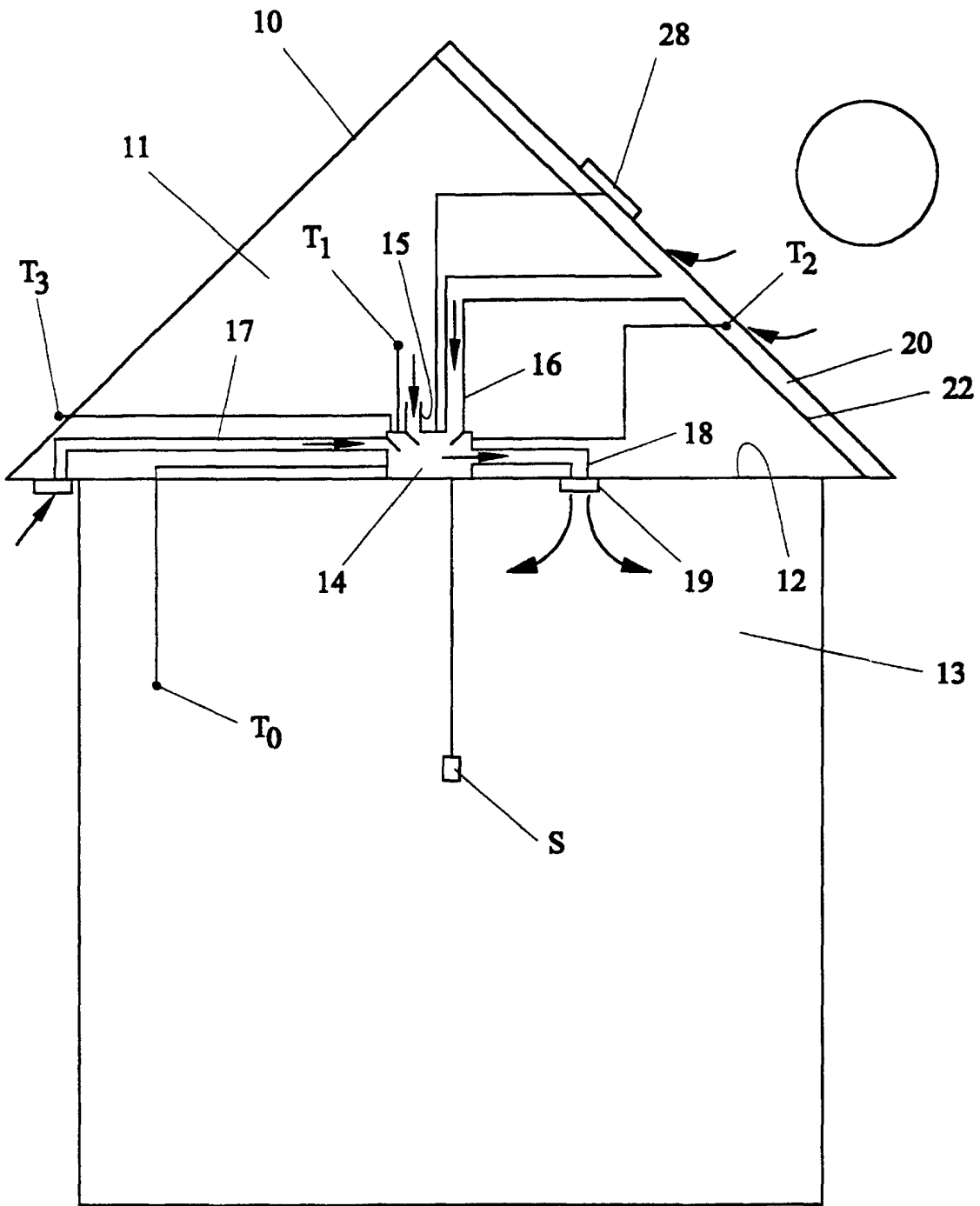

FIG. 1

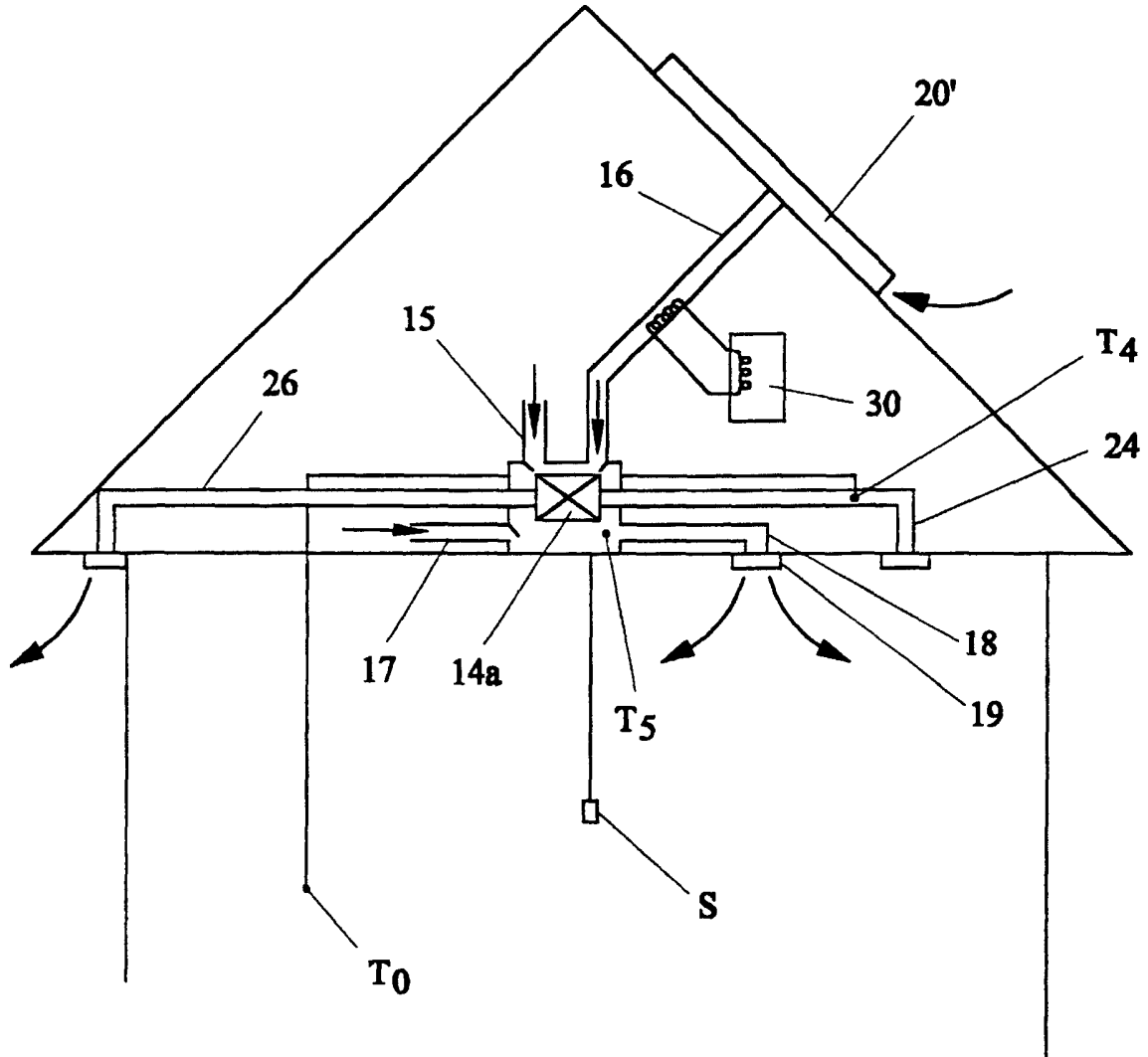

FIG. 2