

S. L. Langdon,

Motor.

No. 100,643.

Patented Mar. 8. 1870.

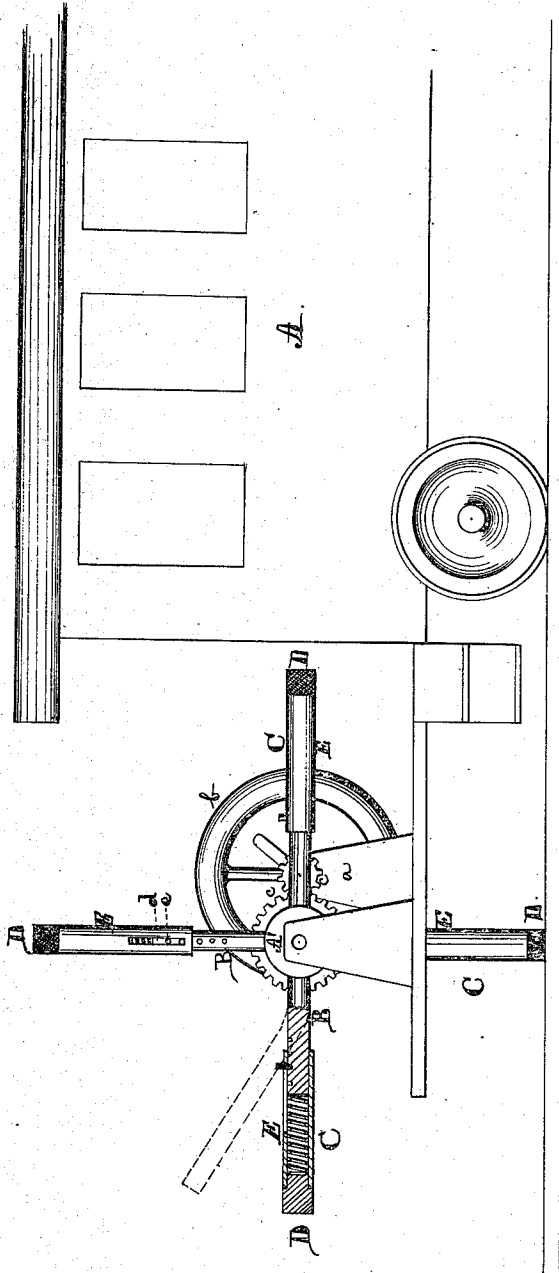

Witnesses:
Charles Huber
Wm. J. Peyton

Inventor:
Sylvester J. Langdon
John A. ...
Atty.

United States Patent Office.

SYLVESTER L. LANGDON, OF NEW ORLEANS, LOUISIANA.

Letters Patent No. 100,643, dated March 8, 1870.

IMPROVEMENT IN MOTIVE POWER FOR CARRIAGES.

The Schedule referred to in these Letters Patent and making part of the same

To all whom it may concern :

Be it known that I, SYLVESTER L. LANGDON, of New Orleans, in the parish of Orleans, and State of Louisiana, have invented a new and useful Improvement in Motive Power; and I do hereby declare the following to be a clear and exact description of the nature thereof, sufficient to enable others skilled in the art to which my invention appertains to fully understand and use the same, reference being had to the accompanying drawings making part of this specification.

The figure is a side view of the device illustrating my invention, partly in section and applied to a car.

My invention consists in a motive power intended to be applied to cars, carriages, and vehicles generally, and is derived from a series of arms having elastic feet, and made to revolve so as to take hold of the ground, the bed of a road, or any foundation especially laid therefor, and thereby propel the conveyance with great rapidity, safety, and surety.

In the drawings—

A may represent a car, carriage, or conveyance of any sort.

In the present case I have represented a car having one of its platforms extended so as to support its working-parts, which form the propelling power.

From the platform there arises standard *a a*, which form the bearings of the shaft to which the fly-wheel *b* is secured.

A series of gearing, *c*, is connected with the fly-wheel in order to communicate motion to a wheel or hub *A'*, which is secured to a shaft properly mounted on arms or standard rising from the platform.

To this hub or wheel there are secured arms *B B*, which radiate therefrom, and may be constructed of wood or metal, either flat, round, or tubular, in the form of a curve or right line, and of any number, thickness, and length, suitable for the purpose intended.

The hub and arms thus produce an armed wheel *A' B*.

To each of the outer ends of the arms is fixed an elastic foot, *C*.

In the present case these feet consist of pieces of rubber, *D*, rigidly connected to tubes *E*, which are made to slide over the arms *B*, or the latter may slide over the former.

A slot, *d*, and pin *e* are respectively formed with each tube and arm, to limit the play of the foot, the pin being adjustable therefor.

Elastic springs may be interposed between the tubes and arms in order to throw out the former, although this can be accomplished by the rubbers *D*, which may project sufficiently into the tubes so as to be compressed when the feet are forced toward the center.

The arm *B* could be made of elastic material, and thereby dispense with the interposed springs.

The operation is as follows:

Power of any kind is to be applied to the fly-wheel *b* or elsewhere, to cause rotation of the arms *B B*. If hand-power is employed, a crank should be connected to the fly-wheel or its shaft.

On rotating the arms the feet reach the ground or bed, or foundation of the road, and take hold thereof, and consequently communicate motion to the car or conveyance *A*.

It will be seen that the distance from the axis of the arms and feet to their extreme ends is greater than that from the axis to the ground or bed, consequently the arms and legs could not pass the center were it not that the feet are elastic, and thus "give."

The momentum of the conveyance and power derived from the fly-wheel and gearing will assist the arms and legs in their operation, and thus render the device easy of manipulation, and produce a rapidity of propulsion and strong power.

The hub *A'* may be dispensed with, and the arms *B* be secured directly to its shaft, but it is preferable to use the hub in view of the strain on the arms, whereby the connection between the arms and shaft must be made extremely strong, and this is accomplished when the hub is employed.

It is not necessary that the aforesaid device be particularly located on the front or rear platform of a vehicle, as it is equally applicable to the sides thereof. In the latter case an armed wheel is placed on each side, both having the same shaft and a single fly-wheel and set of gearing arranged on said shaft.

In some cases rubbers *D* may be applied directly to the ends of the arms. In either case said rubbers take firm hold of the ground, bed, or foundation, to assist in propelling the vehicle, and likewise prevent slipping of the arms.

The device thus specified is simple, practical, and useful.

Having thus described my invention,

What I claim as new, and desire to secure by Letters Patent, is—

1. The series of rotating arms *B B*, operated by suitable mechanism and power, and applied to a vehicle to operate, substantially as set forth.

2. The rubber *D*, applied to the armed wheel *A' B*, so as to come in contact with the ground or road, substantially as and for the purposes described.

3. The rotating arms *B*, carrying elastic feet *C*, substantially as and for the purposes described.

The above signed by me this 8th day of February, 1870.

SYLVESTER L. LANGDON.

Witnesses:

JOHN A. WIEDERSHIEM,
A. B. VANDEMARK.