

(19) World Intellectual Property Organization
International Bureau



(43) International Publication Date
27 September 2007 (27.09.2007)

PCT

(10) International Publication Number
WO 2007/109320 A2

- (51) International Patent Classification:
G06G 7/48 (2006.01)
- (21) International Application Number:
PCT/US2007/007019
- (22) International Filing Date: 20 March 2007 (20.03.2007)
- (25) Filing Language: English
- (26) Publication Language: English
- (30) Priority Data:
60/784,498 21 March 2006 (21.03.2006) US
11/725,227 16 March 2007 (16.03.2007) US
- (71) Applicant (for all designated States except US): **EXXON-MOBIL RESEARCH AND ENGINEERING COMPANY** [US/US]; 1545 Route 22 East, P.O. Box 900, Annandale, NJ 08801-0900 (US).

246 Kinser Road, P.O. Box 927, Anahuac, TX 77514 (US). **ORSAK, Steven, M.** [US/US]; 3303 Fleming, Baytown, TX 77521 (US). **ALAGAPPAN, Perry** [US/US]; 15411 Palm Grass Court, Houston, TX 77059-5833 (US).

(74) Agents: **PURWIN, Paul, E.** et al.; Exxonmobil Research And Engineering Company, 1545 Route 22 East, P.O. Box 900, Annandale, NJ 08801-0900 (US).

(81) Designated States (unless otherwise indicated, for every kind of national protection available): AE, AG, AL, AM, AT, AU, AZ, BA, BB, BG, BH, BR, BW, BY, BZ, CA, CH, CN, CO, CR, CU, CZ, DE, DK, DM, DZ, EC, EE, EG, ES, FI, GB, GD, GE, GH, GM, GT, HN, HR, HU, ID, IL, IN, IS, JP, KE, KG, KM, KN, KP, KR, KZ, LA, LC, LK, LR, LS, LT, LU, LY, MA, MD, MG, MK, MN, MW, MX, MY, MZ, NA, NG, NI, NO, NZ, OM, PG, PH, PL, PT, RO, RS, RU, SC, SD, SE, SG, SK, SL, SM, SV, SY, TJ, TM, TN, TR, TT, TZ, UA, UG, US, UZ, VC, VN, ZA, ZM, ZW.

(84) Designated States (unless otherwise indicated, for every kind of regional protection available): ARIPO (BW, GH, GM, KE, LS, MW, MZ, NA, SD, SL, SZ, TZ, UG, ZM, ZW), Eurasian (AM, AZ, BY, KG, KZ, MD, RU, TJ, TM), European (AT, BE, BG, CH, CY, CZ, DE, DK, EE, ES, FI, FR, GB, GR, HU, IE, IS, IT, LT, LU, LV, MC, MT, NL, PL, PT, RO, SE, SI, SK, TR), OAPI (BF, BJ, CF, CG, CI, CM, GA, GN, GQ, GW, ML, MR, NE, SN, TD, TG).

[Continued on next page]

(54) Title: APPLICATION OF ABNORMAL EVENT DETECTION (AED) TECHNOLOGY TO POLYMERS PROCESS

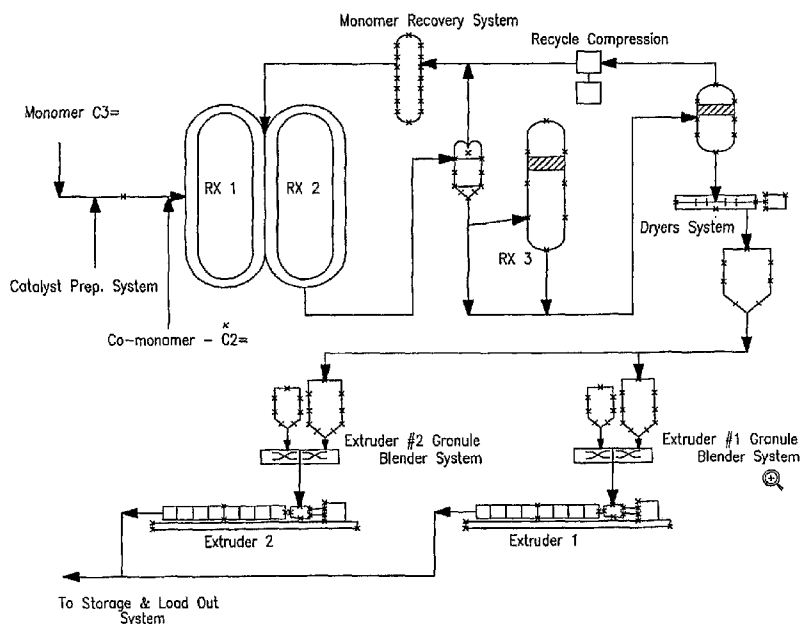

(57) Abstract: The present invention is a method and system for detecting an abnormal event for process units of a Polymers Unit. The method compares the operation of the process units to statistical, engineering or heuristic models. The statistical models are developed by principle components analysis of the normal operation for these units. In addition, the engineering models are based on correlation analysis between variables or simple engineering calculations. If the difference between the operation of a process unit and the normal model result indicates an abnormal condition, then the cause of the abnormal condition is determined and corrected.

WO 2007/109320 A2



Published:

— without international search report and to be republished upon receipt of that report

For two-letter codes and other abbreviations, refer to the "Guidance Notes on Codes and Abbreviations" appearing at the beginning of each regular issue of the PCT Gazette.

- 1 -

APPLICATION OF ABNORMAL EVENT DETECTION (AED)
TECHNOLOGY TO POLYMERS PROCESS

BACKGROUND OF THE INVENTION

[0001] The present invention relates to the operation of a Polymer Process with specific example applied to a Polypropylene Process (PP). PP in this example comprises of nine operation areas - the catalyst preparation area (Cat Prep), reactors (RX), recycle gas compressors, recycle gas recovery system, the dryers, two granule areas and two extruders system. In particular, the present invention relates to determining when the process is deviating from normal operation and automatic generation of notifications isolating the abnormal portion of the process.

[0002] Polypropylene process (PP) is one of the most important and widely used processes for polymerizing propylene to produce polypropylene. Polypropylene is then used as intermediate materials in producing plastic products such as milk bottles, soft drink bottles, hospital gowns, diaper linings etc. The PP is a very complex and tightly integrated system comprising of the catalyst preparation unit, reactors, recycle gas compressors, recycle gas recovery system, the dryer, granule systems and two extruders. Figure 23 shows a typical PP layout. The PP process employs catalysts in the form of very fine particles mixed with cold oil and grease to form a very thick and paste - like mixture. The thick and paste-like property of the catalyst mixture makes it difficult to pump catalysts into the reactors, thus makes the catalyst system prone to plugging problems. The catalyst mixture and the fresh monomer feed (Propylene or C₃=) along with the co-monomer (Ethylene) are fed into two large reactors (RX 1 & RX 2) in series. In the reactors, when the monomers are in contact with the catalysts, a very exothermic reaction occurs and polymer granules are formed in the reactor slurry. To remove the heat generated by the reaction, cooling water is continuously pumped around the reactor jackets to

- 2 -

maintain the reactor temperature at a desired target. In each of the first two reactors, there is a big pump continuously circulating the polymer slurry to prevent the formation of chunks. Depending on the product grades, the PP has two distinct reactor configuration modes - One configuration mode utilizes two reactors (RX 1 & 2) in series, while the other mode requires a third reactor (RX 3) in series with the first two reactors. The polymer slurry exiting the reactors is pumped into the separators where un-reacted monomers are removed and sent to the monomer recovery system before recycling back to the reactors. The polymer granules are fed into the dryer system where any last trace of monomers is removed, any trace of catalyst residues is steam stripped and the granules are dried off. The dry polymer granules are sent to the granule system where they are blended with additives and sent to the two extruders for pelletization. The polymer pellets are then sent the storage system or to the load out system.

[0003] Due to the complicated dynamic nature of the PP, abnormal process operations can easily result from various root causes that can escalate to serious problems and even cause plant shutdowns. These operations can have significant safety and economic implications ranging from lost production, equipment damage, environmental emissions, injuries and death. A primary job of the operator is to identify the cause of the abnormal situation and execute compensatory or corrective actions in a timely and efficient manner.

[0004] The current commercial practice is to use advanced process control applications to automatically adjust the process in response to minor process disturbances, to rely on human process intervention for moderate to severe abnormal operations, and to use automatic emergency process shutdown systems for very severe abnormal operations. The normal practice to notify the console operator of the start of an abnormal process operation is through process alarms. These alarms are triggered when key process measurements (temperatures, pressures, flows, levels and compositions) violate predefined static set of

- 3 -

operating ranges. This notification technology is difficult to provide timely alarms while keeping low false positive rate when the key measurements are correlated for complicated processes such as PP.

[0005] There are more than 450 key process measurements, which cover the operation of a typical PP. Under the conventional Distributed Control System (DCS) system, the operator must survey this list of sensors and its trends, compare them with a mental knowledge of normal PP operation, and use his/her skills to discover the potential problems. Due to the very large number of sensors in an operating PP, abnormalities can be and are easily missed. With the current DCS based monitoring technology, the only automated detection assistance an operator has is the DCS alarm system which is based on the alarming of each sensor when it violates predetermined limits. In any large-scale complex process such as the PP, this type of notification is clearly a limitation as it often comes in too late for the operator to act on and mitigate the problem. The present invention provides a more effective notification to the operator of the PP.

SUMMARY OF THE INVENTION

[0006] The present invention is a method and system for detecting an abnormal event for the polymer process unit. In a preferred embodiment, the polymer process is a polyolefin process. In another preferred embodiment, the polyolefin process is a polyethylene or polypropylene process or a combination thereof. It utilizes the existing Abnormal Event Detection (AED) technology but with modifications to handle the complicated dynamic nature of the PP due to the frequent changes in operating conditions due to grade switches, and sometimes changes in the reactor configuration to produce different product grades. The modifications include the development of models for different product grades, the mechanism to detect the onset of product grade switching state, the notification suppression during the grade transitional duration, and the automatic switching of models presented to the operator based on changes in the

- 4 -

operating modes, and reactor configurations. The automatic switching of the models is in-apparent to the operators as they still utilize the same operator interfaces. The PP AED application includes a number of highly integrated dynamic process units. The method compares the current operation to various models of normal operation for the covered units. If the difference between the operation of the unit and the normal operation indicates an abnormal condition in a process unit, then the cause of the abnormal condition is determined and relevant information is presented efficiently to the operator to take corrective actions.

BRIEF DESCRIPTION OF THE DRAWINGS

- [0007] Figure 1 shows how the information in the online system flows through the various transformations, model calculations, fuzzy Petri nets and consolidation to arrive at a summary trend which indicates the normality/ abnormality of the process areas.
- [0008] Figure 2 shows a valve flow plot to the operator as a simple x-y plot.
- [0009] Figure 3 shows three-dimensional redundancy expressed as a PCA model.
- [0010] Figure 4 shows a schematic diagram of a fuzzy network setup.
- [0011] Figure 5 shows a schematic diagram of the overall process for developing an abnormal event application.
- [0012] Figure 6 shows a schematic diagram of the anatomy of a process control cascade.
- [0013] Figure 7 shows a schematic diagram of the anatomy of a multivariable constraint controller, MVCC.
- [0014] Figure 8 shows a schematic diagram of the on-line inferential estimate of current quality.

- 5 -

- [0015] Figure 9 shows the KPI analysis of historical data.
- [0016] Figure 10 shows a diagram of signal to noise ratio.
- [0017] Figure 11 shows how the process dynamics can disrupt the correlation between the current values of two measurements.
- [0018] Figure 12 shows the probability distribution of process data.
- [0019] Figure 13 shows illustration of the press statistic.
- [0020] Figure 14 shows the two-dimensional energy balance model.
- [0021] Figure 15 shows a typical stretch of Flow, Valve Position, and Delta Pressure data with the long period of constant operation.
- [0022] Figure 16 shows a type 4 fuzzy discriminator.
- [0023] Figure 17 shows a flow versus valve paraeto chart.
- [0024] Figure 18 shows a schematic diagram of operator suppression logic.
- [0025] Figure 19 shows a schematic diagram of event suppression logic.
- [0026] Figure 20 shows the setting of the duration of event suppression.
- [0027] Figure 21 shows the event suppression and the operator suppression disabling predefined sets of inputs in the PCA model.
- [0028] Figure 22 shows how design objectives are expressed in the primary interfaces used by the operator
- [0029] Figure 23 shows the simplified schematic layout of a PP
- [0030] Figure 24 shows the operator display of all the problem monitors for the PP operation.
- [0031] Figure 25 shows the fuzzy-logic based continuous abnormality indicator for the Catalyst Plugging problem in the Poly8 Operation Area.

- 6 -

[0032] Figure 26 shows AED alerts of the Catalyst Plugging Problem in both the Poly 8 Operation, and the Poly8 Cat Area abnormality monitors.

[0033] Figure 27 shows that complete drill down for the Catalyst Plugging problem in the Poly8 Operation Area along with the supporting evidences.

[0034] Figure 28 shows the drill down for the Catalyst Plugging problem in the Poly8 Cat Area with location of problem area.

[0035] Figure 29 shows the fuzzy logic network for detection of the Catalyst Plugging problem in the Poly8 Cat Area.

[0036] Figure 30 shows Fuzzy Logic Network couple with rules developed for automatic switching of PCA models underlying Poly 8 Operation

[0037] Figure 31 shows the Fuzzy Logic Network developed for automatic detection of grade switches and for setting process transitional duration

[0038] Figure 32 shows A Pareto Chart displaying the residuals of the deviating sensors corresponding to the Catalyst Plugging Problem highlighted in Figure 27.

[0039] Figure 33 shows the multi-trends for the tags in Figure 32. It shows the tag values and also the model predictions.

[0040] Figure 34 shows the pareto chart ranking the deviating valve flow models

[0041] Figure 35 shows the X-Y plot for a valve flow model - valve opening versus the flow.

[0042] Figure 36 shows the drill down for the controller monitors and Sensor validation checks.

[0043] Figure 37 shows the fuzzy logic network for the controller monitors and Sensor validation checks.

- 7 -

- [0044] Figure 38 shows the drill down for the heuristic models.
- [0045] Figure 39 shows the fuzzy logic for the heuristic models
- [0046] Figure 40 shows a Valve Flow Monitor Fuzzy Net.
- [0047] Figure 41 shows an example of valve out of controllable range.
- [0048] Figure 42 shows a standard statistical program, which plots the amount of variation modeled by each successive PC.
- [0049] Figure 43 shows the Event Suppression display.
- [0050] Figure 44 shows the AED Event Feedback Form.

DETAILED DESCRIPTION OF THE PREFERRED EMBODIMENTS

[0051] The present invention is a method to provide early notification of abnormal conditions in sections of the PP to the operator using a modified Abnormal Event Detection (AED) technology. The modifications include the development of different models for different product grades, and the automatic switching of models presented to the operator based on changes in the operating modes, and reactor configurations. The switching of the models is in-apparent to the operators as they still utilize the same operator interfaces. The PP AED application includes a number of highly integrated dynamic process units. The method compares the current operation to various models of normal operation for the covered units. If the difference between the operation of the unit and the normal operation indicates an abnormal condition in a process unit, then the cause of the abnormal condition is determined and relevant information is presented efficiently to the operator to take corrective actions.

[0052] In contrast to alarming techniques that are snapshot based and provide only an on/off indication, this method uses fuzzy logic to combine multiple supportive evidences of abnormalities that contribute to an operational problem and estimates its probability in real-time. This probability is presented

- 8 -

as a continuous signal to the operator thus removing any chattering associated with the current single sensor alarming-based on/off methods. The operator is provided with a set of tools that allow complete investigation and drill down to the root cause of a problem for focused action. This approach has been demonstrated to furnish the operator with advanced warning of the abnormal operation that can be minutes to hours earlier than the conventional alarm system. This early notification lets the operator make informed decision and take corrective action to avert any escalation or mishaps. This method has been successfully applied to the PP. As an example, Figure 27 shows the complete drill down for the Catalyst Plugging problem in the Poly8 Operation area (the details of the subproblems are described later).

[0053] The PP AED application uses diverse sources of specific operational knowledge to combine indications from Principal Component Analysis (PCA), correlation-based engineering models such as Valve Flow models (VFM), heuristic models (HM) or specific "operating rules-of-thumb" collected from experienced operators that are constructed in the fuzzy logic network, Controller Monitoring and Sensor Consistency Check (CM) to monitor relevant sensors through the use of fuzzy logic networks. This fuzzy logic network aggregates the evidence and indicates the combined confidence level of a potential problem. Therefore, the network can detect a problem with higher confidence at its initial developing stages and provide crucial lead-time for the operator to take compensatory or corrective actions to avoid serious incidents. This is a key advantage over the present commercial practice of monitoring PP based on single sensor alarming from a DCS system. Very often the alarm comes in too late for the operator to mitigate an operational problem due to the complicated, fast dynamic nature of PP or multiple alarms could flood the operator, confusing him/her and thus hindering rather than aiding in response.

- 9 -

[0054] The PP unit is divided into equipment groups (referred to as key functional sections or operational sections). These equipment groups may be different for different PP units depending on its design. The procedure for choosing equipment groups which include specific process units of the PP unit is described in Appendix 1.

[0055] In the preferred embodiment, the present invention divides the Polypropylene Unit (PP) operation into the following overall monitors

1. Overall Polymerization Operation (Poly8 Operation)
2. Overall Dryers Operation (Dryer8 Operation)
3. Overall Extruder1 Operation (EX801 Operation)
4. Overall Extruder1 Operation (EX831 Operation)

and these special concern monitors

1. Flow Control Valve Monitoring (Poly8 Control Valves)
2. Catalyst Area Alerts (Poly8 Cat Area Alerts)
3. Sensor Checks (Poly8 Sensors)
4. Sensor Checks (Poly4 Sensors)
5. 831 Granules Area Alerts
6. 801 Granules Area Alerts
7. Finishing 4 Area Alerts

[0056] The overall monitors carry out "gross model checking" to detect any deviation in the overall operation and cover a large number of sensors. The special concern monitors cover areas with potentially serious concerns and consist of focused models for early detection. In addition to all these monitors the application provides for several practical tools such as those dealing with

- 10 -

suppression of notifications generated from normal/routine operational events and elimination of false positives due to special cause operations.

A. Operator Interface

[0057] The operator user interface is a critical component of the system as it provides the operator with a bird's eye view of the process. The display is intended to give the operator a quick overview of PP operations and indicate the probability of any developing abnormalities.

[0058] Figure 24 shows the operator interface for the system. A detailed description on operator interface design considerations is provided in subsection IV "Operator Interaction & Interface Design" under section "Deploying PCA models and Simple Engineering Models for AED" in Appendix 1 section IV, under The interface consists of the abnormality monitors mentioned above. This was developed to represent the list of important abnormal indications in each operation area. Comparing model results with the state of key sensors generates abnormal indications. Fuzzy logic is used to aggregate abnormal indications to evaluate a single probability of a problem. Based on specific knowledge about the normal operation of each section, we developed a fuzzy logic network to take the input from sensors and model residuals to evaluate the probability of a problem. Figure 25 shows the probability for the Catalyst Plugging problem in the Poly8 Cat area using the corresponding fuzzy logic network shown in Figure 29. Figure 26 shows that the Catalyst Plugging Problem is seen in both the Poly 8 Operation and Poly8 Cat Area abnormality monitors. Figure 27 shows the complete drill down of the catalyst plugging problem in the Poly8 Operation Area. Figure 28 shows the complete drill down of the catalyst plugging problem in the Poly8 Cat Area identifying the location of the plug. Figure 29 shows the fuzzy logic network with the green nodes indicating the subproblems that combine together to determine the final certainty of the Catalyst Plugging Problem in the Poly8 Cat Area. The estimated probability of an abnormal

- 11 -

condition is shown to the operating team in a continuous trend to indicate the condition's progression as shown in Figure 26. This gives the operator a significant advantage to get an overview of the health of the process than having to check the status of each sensor individually. More importantly, it gives the operator 'peace-of-mind' - due to its extensive coverage, chances of missing any event are remote. So, it can also be used as a normality-indicator. When the probability reaches 0.6, the problem indicator turns yellow (warning) and the indicator turns red (alert) when the probability reaches 0.9.

[0059] This invention comprises five Principle Component Analysis (PCA) models to cover the areas of Cat. Prep., the Reactors including two Loop Reactors (RX 1 & 2) and a Gas Phase Reactor (RX 3), the Monomer Gas Recycle System, Recycle Gas Compressor, the dryers, the granule areas and two extruders system including Extruders 801 area, and Extrusion EX831 area. The coverage of the PCA models was determined based on the interactions of the different processing units and the models have overlapping sensors to take this into account. Since there is significant interaction in the Cat. Prep, the Reactors, and Monomer Gas Recycle system and the Recycle Gas Compressor, these areas are combined to represent the "Poly8 Operation". Since PP has two distinct operating conditions using two reactor configuration modes to produce different product grades – one mode using two reactors in series, and the other mode using three reactors in series, it is necessary to have two PCA models to handle those two modes. However, only one PCA model is on-line at a time to underlie "Poly8 Operation". In this case, fuzzy logic network is used to automatically switch the online PCA model to the appropriate model. Figure 30 shows the fuzzy logic network designed to automatically detect the onset of the switch and switch the online PCA model underling Poly8 Operation. The third PCA model combines the dryers, and the granule areas to represent the "Dryers8 Operation". The fourth and fifth PCA models represent the two extrusion areas labeled as "EX801 Operation", and "EX831 Operation". In addition, there are a number

- 12 -

of special concern monitors intended to watch conditions that could escalate into serious events. The objective is to detect the problems early on so that the operator has sufficient lead time to act.

[0060] Under normal operations, the operator executes several routine actions such as feed rate changes, setpoint moves that could produce short-lived high residuals in some sensors in the PCA models. Since such notifications are redundant and do not give new information, this invention has mechanism built-in to detect their onset and suppress the notifications. As part of PP routine operations, product grade switches are done very frequently, which make PP a very fast dynamic process. There are grade switches within a product grade family (called flying grade-switch) that do not require changes in reactor configuration). In this case, operators can make large setpoint changes to some key product-quality controllers to steer the PP to a new operation state. During the transitional state, some sensors will experience high residuals and therefore depict abnormal conditions. The existing AED notification - suppression mechanism could not handle the grade switches, and therefore modifications were made. The modifications include mechanism to detect the onset of a grade switch and set a grade -switch state. The grade switch state is then latched on for a certain period of time to depict a process transitional duration. During the transitional duration, the notifications are suppressed using the existing mechanism to avoid flooding operators with nuisance alerts, as they are already aware of the condition changes, and are already keeping a close watch of the PP. However, during the transitional duration, AED continues to update PCA model parameters, and once the PP reaches its new steady state, AED resumes its notification. Figure 31 shows the added fuzzy network logics for automatic detection of grade switches and for setting the transitional duration. There are also product grade switches requiring changes in reactor configuration (from two reactor mode to three reactor mode and vice versa). This modification of the AED notification suppression also handles the suppression for this case.

- 13 -

[0061] The operator is informed of an impending problem through the warning triangles that change color from green to yellow and then red. The application provides the operator with drill down capability to further investigate the problem by viewing a list of prioritized subproblems. This novel method provides the operator with drill down capabilities to the subproblems. This enables operators to narrow down the search for the root cause, and assists them in isolating and diagnosing the root cause of the condition so that compensatory or corrective actions can be taken sooner than later. As previously shown in Figure 27, a pareto chart indicating the residuals of the deviating sensors sorted by their deviations is displayed when operators click on the red triangles to drill down to the subproblems.

[0062] The application uses the pareto-chart approach quite extensively to present information to the operator. The sequence of presentation is in decreasing order of individual deviation from normal operation. This allows a succinct and concise view of the process narrowed down to the few critical bad actors so the console operator can make informed decisions about course of action. Figure 32 demonstrates this functionality through a list of sensors organized in a pareto-chart. Upon clicking on an individual bar, a custom plot showing the tag trend versus model prediction for the sensor is created. The operator can also look at trends of problem sensors together using the "multi-trend view". For instance, Figure 33 shows the trends of the value and model predictions of the sensors in the Pareto chart of Figure 32. Figure 34 shows the same concept, this time applied to the ranking of valve-flow models (VFM) based on the normalized-projection-deviation error. Clicking on the bar in this case, generates an X-Y scatter plot that shows the current operation point in the context of the bounds of normal operation (Figure 35).

[0063] In addition to the PCA models, there are a number of special concern monitors built using engineering relationships such as the VFM, the

- 14 -

controller monitorings (CM), the sensor checks (SC), and the heuristic models (HM). The VFMs cover critical equipment in the Poly8 Control Valves. The HMs cover the critical equipment plugging problems in the Poly8 Cat, the 801 Granule, the 831 Granule, and the Finishing4 Areas. The CM and SC covers the critical controllers and sensors in the Poly8 Sensor Check, and Poly4 Sensor Check Areas. Underlying these monitors are fuzzy-logic networks that generate a single abnormality signal in each area. Figure 36 shows the drill down for the controller monitors and Sensor checks. Figure 37 shows the fuzzy logic network for the controller monitors and Sensor checks. Figure 38 shows the drill down for the heuristic models. Figure 39 shows the fuzzy logic for the heuristic models

[0064] In summary, the advantages of this invention include:

1. The modification of existing Abnormal Event Detection (AED) technology to successfully handle the frequent changes in operating conditions due to grade switches, and sometimes changes in the reactor configuration to produce different product grades.
2. The decomposition of the entire PP operation into 11 operational areas – the Polymerization Reactors, the Dryers, the Extrusion EX831, the Extrusion EX801, the Poly8 Flow Control Valves, the Poly8 Catalyst Preparation, Poly8 Sensors, 831 Granules, 801 Granules, and Finishing 4 for supervision .
3. The operational condition of the entire PP is summarized into 11 single alerts
4. The PCA models provide model predictions of the 450+ sensors covered in the models.

- 15 -

5. The abnormal deviations of these sensors are summarized by the 5 alerts based on the Sum of Square Error of the 5 PCA models
6. The valve-flow models provide a powerful way to monitor control loops, which effect control actions and thus can be the source or by affected by upsets.
7. The heuristic models covering the critical equipment plugging problems in the Poly8 Cat, the 801 Granule, the 831 Granule, and the Finsihing4 Areas add enhanced focused and early detection capability.
8. The controller monitors and the sensor checks add enhanced focused and early detection capability for key process variables.
9. Events resulting from special cause/routine operations are suppressed to eliminate the false positives. The enormous dimensionality reduction from 450+ individual tags to just 12 signals significantly cuts down on the false positive rate. The PCA modeling approach inherently resolves the single sensor alarming issue in an elegant manner.

B. Development and Deployment of AED Models for PP

[0065] The application has PCA models, engineering models and heuristics to detect abnormal operation in a PP. The first steps involve analyzing the concerned unit for historical operational problems. This problem identification step is important to define the scope of the application.

[0066] The development of these models is described in general in Appendix 1. Some of the specific concerns around building these models for the PP unit are described below.

Problem Identification

[0067] The first step in the application development is to identify a significant problem, which will benefit process operations. The abnormal event detection application in general can be applied to two different classes of problem. The first is a generic abnormal event application that monitors an entire process area looking for any abnormal event. This type will use several hundred measurements, but does not require a historical record of any specific abnormal operations. The application will only detect and link an abnormal event to a portion (tags) of the process. Diagnosis of the problem requires the skill of the operator or engineer.

[0068] The second type is focused on a specific abnormal operation. This type will provide a specific diagnosis once the abnormality is detected. It typically involves only a small number of measurements (5 -20), but requires a historical data record of the event. These models can be PCA based or simple engineering correlation such as the Valve Flow (VF) models monitoring the main process flow valves for broken correlation or out-of-range operation that are constructed based on historical data of sensors around the flow control valve such as upstream/downstream pressure, flow measurement and valve output; the Heuristic Models (HM) are specific "operating rules-of-thumb" collected from experienced operators and are constructed in the fuzzy logic network to identify those circumstances that violate these rules-of-thumb; the Controller Monitoring (CM) and Sensor Check (SC) monitor the performance of the controller or sensor to detect a frozen instrument, a controller malfunction, or an instrument that has a highly variant reading. This invention uses the above models in order to provide extensive coverage. The operator or the engineer would then rely on their process knowledge / expertise to accurately diagnose the cause. Typically most of the events seem to be primarily the result of problems with the instruments and valves.

- 17 -

[0069] The following problem characteristics should be considered when selecting an abnormal event detection problem: Infrequent abnormalities (every 3 - 4 months) may not justify the effort to create an abnormal event detector. Also, when a particular abnormality occurs only every 3 or 4 months, an individual operator may go for years without seeing the event. As a consequence, he would not know what to do once the event finally occurs. Therefore the problem identification should be broad enough that the operator would be regularly interacting with the application.

[0070] When scoping the problem, it is common to get the wrong impression from site personnel that there would not be a sufficient number of abnormal events to justify an abnormal event detection application. In general, an overly low estimate of how frequently abnormal events affect the process occurs because:

- Abnormal events are often not recorded and analyzed. Only those that cause significant losses are tracked and analyzed.
- Abnormal events are often viewed as part of normal operations since operators deal with them daily.

Unless there is a regularly repeating abnormal event, the application should cover a large enough portion of the process to "see" abnormal events on a regular basis (e.g. more than 5 times each week).

I. PCA Models

[0071] The PCA models are the heart of the PP AED. PCA transforms the actual process variables into a set of 'orthogonal' or independent variables called Principal Components (PC) which are linear combinations of the original variables. It has been observed that the underlying process has a number of degrees of freedom which represent the specific independent effects that

- 18 -

influence the process. These different independent effects show up in the process data as process variation. Process variation can be due to intentional changes, such as feed rate changes, or unintentional disturbances, such as ambient temperature variation.

[0072] Each principal component captures a unique portion of the process variability caused by these different independent influences on the process. The principal components are extracted in the order of decreasing process variation. Each subsequent principal component captures a smaller portion of the total process variability. The major principal components should represent significant underlying sources of process variation. As an example, the first principal component often represents the effect of feed rate changes since this is usually the largest single source of process changes.

[0073] The application is based on a Principal Component Analysis, PCA, of the process, which creates an empirical model of "normal operations". The process of building PCA models is described in detail in the section "Developing PCA Models for AED" in Appendix 1. The following will discuss the special considerations that are necessary to apply PCA toward creating an abnormal event detection application for Polymers Process.

PP PCA Model Development

[0074] There are five PCA models developed for PP. The two PCA models underlying the Poly8 Operation to cover the two reactor configuration modes are Poly8_TCR and Poly8_ICP. These two PCA models include sensors in the Catalyst Preparation, the Reactors, the Monomer Gas Recycle system and the Recycle Gas Compressor because there is significant interaction between these systems. The Poly8_TCR PCA model started with an initial set of 321 tags, which was then refined to 155 tags. The Poly8_ICP PCA model started with an initial set of 414 tags, which was then refined to 200 tags. The Dryer8 model started with an initial set of 76 tags in the dryers, and the granule areas, which

- 19 -

was then refined to 37 tags. The EX801 model narrowed down from 43 to 25 tags to cover the extrusion 1 area. The EX831 model narrowed down from 43 to 25 tags to cover the extrusion 2 area. The details of the Poly8_TCR PCA model is shown in Appendix 2A, the Poly8_ICP PCA model in Appendix 2B, the Dryer8 PCA model in Appendix 2C, the EX801 PCA model in Appendix 2D, the EX831PCA model in Appendix 2E. This allows extensive coverage of the overall PP operation and early alerts.

[0075] The PCA model development comprises of the following steps:

- 1) Input Data and Operating Range Selection
- 2) Historical data collection and pre-processing
- 3) Data and Process Analysis
- 4) Initial model creation
- 5) Model Testing and Tuning
- 6) Model Deployment

[0076] The general principles involved in building PCA models are described in the subsection I "Conceptual PCA Model Design" under section "Developing PCA Models for AED" in Appendix 1. These steps constitute the primary effort in model development. Since PCA models are data-driven, good quality and quantity of training data representing normal operations is very crucial. The basic development strategy is to start with a very rough model, then to successively improve that model's fidelity. This requires observing how the model compares to the actual process operations and re-training the model based on these observations. The steps are briefly described next.

Input Data and Operating Range Selection

[0077] As the list of tags in the PCA model dictates coverage, we start with a comprehensive list of all the tags in the concerned areas. The process of

- 20 -

selecting measurements and variables is outlined in subsection II "Input Data and Operating Range Selection" under the section "Developing PCA Models for AED" in Appendix 1. Any measurements that were known to be unreliable or exhibit erratic behavior should be removed from the list. Additional measurement reduction is performed using an iterative procedure once the initial PCA model is obtained. The specific concern around input data selection for PP is the development of tag list to handle the two reactor configuration modes. The tag list for the three - reactor mode includes tags to cover the operation of all three reactors, while the tag list for the two – reactor mode contains tags for two reactors. The specific concern around operating range selection for PP is to make sure the range covers the process operating conditions of all product grades.

Historical Data collection and Pre-Processing

[0078] Developing a good model of normal operations requires a training data set of normal operations. This data set should:

- Span the normal operating range
- Only include normal operating data

[0079] Because it is very rare to have a complete record of the abnormal event history at a site, historical data can only be used as a starting point for creating the training data set. Operating records such as Operator logs, Operator Change Journals, Alarm Journals, Instrument Maintenance records provide a partial record of the abnormal process history. The process of data collection is elaborated upon in subsection III "Historical Data collection" under the section "Developing PCA Models for AED" in Appendix I.

[0080] In the PP case, the historical data spanned 1.5 years of operation to cover the production of all product grades as well as both summer and winter seasons. With one-minute averaged data the number of time points turn out to be

- 21 -

around 700,000+ for each tag. In order to make the data-set more manageable while still retaining underlying information, the tag list was divided up into two sub-sets of tags for data collection and analysis.

[0081] Basic statistics such as average, min/max and standard deviation are calculated for all the tags to determine the extent of variation/information contained within. Also, operating logs were examined to remove data contained within windows with known unit shutdowns or abnormal operations. Each candidate measurement was scrutinized to determine appropriateness for inclusion in the training data set.

Creating Balanced Training Data Set

[0082] Using the operating logs, the historical data is divided into periods with known abnormal operations and periods with no identified abnormal operations. The data with no identified abnormal operations will be the preliminary training data set. For PP, operating logs were studied to determine the time periods when each product grade is produced. The historical data set is then divided up and saved by the grade families. Each grade family data set is then analyzed for exclusion of periods with known abnormal operations and periods with no identified abnormal operations.

[0083] Once these exclusions have been made the first rough PCA model is built for each grade family. Since this is going to be a very rough model the exact number of principal components to be retained is not important. This should be no more than 5% of the number measurements included in the model. The number of PCs should ultimately match the number of degrees of freedom in the process, however this is not usually known since this includes all the different sources of process disturbances. There are several standard methods for determining how many principal components to include. Also at this stage the statistical approach to variable scaling should be used: scale all variables to unit variance.

- 22 -

[0084] The training data set should now be run through this preliminary model to identify time periods where the data does not match the model. These time periods should be examined to see whether an abnormal event was occurring at the time. If this is judged to be the case, then these time periods should also be flagged as times with known abnormal events occurring. These time periods should be excluded from the training data set and the model rebuilt with the modified data. The process of creating balanced training data sets using data and process analysis is outlined in Section IV "Data & Process Analysis" under the section "Developing PCA Models for AED" in Appendix 1.

Initial Model Creation

[0085] The model development strategy is to start with a very rough model (the consequence of a questionable training data set) then use the model to gather a high quality training data set. This data is then used to improve the model, which is then used to continue to gather better quality training data. This process is repeated until the model is satisfactory.

[0086] Once the specific measurements have been selected and the training data set has been built, the model can be built quickly using standard statistical tools. An example of such a program showing the percent variance captured by each principle component is shown in Figure 42.

The model building process is described in Section V "Model Creation" under the section "Developing PCA Models for AED" in Appendix 1.

Model Testing and Tuning

[0087] Once the initial model has been created, it needs to be enhanced by creating a new training data set. This is done by using the model to monitor the process. Once the model indicates a potential abnormal situation, the engineer should investigate and classify the process situation. The engineer will find three different situation, either some special process operation is occurring, an

- 23 -

actual abnormal situation is occurring, or the process is normal and it is a false indication.

[0088] The process data will not have a gaussian or normal distribution. Consequently, the standard statistical method of setting the trigger for detecting an abnormal event from the variability of the residual error should not be used. Instead the trigger point needs to be set empirically based on experience with using the model. Section VI "Model Testing & Tuning" under the section "Developing PCA Models for AED" in Appendix 1 describes the Model testing and enhancement procedure.

PCA Model Deployment

[0089] Successful deployment of AED on a process unit requires a combination of accurate models, a well designed user interface and proper trigger points. The detailed procedure of deploying PCA model is described under "Deploying PCA Models and Simple Engineering Models for AED" in Appendix 1.

[0090] Over time, the developer or site engineer may determine that it is necessary to improve one of the models. Either the process conditions have changed or the model is providing a false indication. In this event, the training data set could be augmented with additional process data and improved model coefficients could be obtained. The trigger points can be recalculated using the same rules of thumb mentioned previously.

[0091] Old data that no longer adequately represents process operations should be removed from the training data set. If a particular type of operation is no longer being done, all data from that operation should be removed. After a major process modification, the training data and AED model may need to be rebuilt from scratch.

- 24 -

[0092] In addition to the PCA models, there are a number of special concern monitors intended to watch conditions that could escalate into serious events. These monitors were developed based on simple engineering correlation such as the Valve Flow models (VFM), the Controller Monitoring (CM) and Sensor Check (SC), or the specific "operating rules-of-thumb" collected from experienced operators (heuristic models – HM).

II. Other PP AED Models

Engineering Models Development

[0093] The engineering models comprise of correlation-based models focused on specific detection of abnormal conditions. The detailed description of building engineering models can be found under "Simple Engineering Models for AED" section in Appendix 1.

[0094] The engineering model requirements for the PP application were determined by performing an engineering evaluation of historical process data and interviews with console operators and equipment specialists. The engineering evaluation included areas of critical concern and worst case scenarios for PP operation. To address the conclusions from the engineering assessment, the following engineering models were developed for the PP AED application:

- Valve-Flow Models (VFM)
- Controller monitors (CM)
- Sensor Checks (SC)

[0095] The Flow-Valve position consistency monitor was derived from a comparison of the measured flow (compensated for the pressure drop across the valve) with a model estimate of the flow. These are powerful checks as the condition of the control loops are being directly monitored in the process. The model estimate of the flow is obtained from historical data by fitting coefficients

- 25 -

to the valve curve equation (assumed to be either linear or parabolic). In the PP AED application, 20 flow/valve position consistency models were developed. An example is shown in Figure 35 for the Monomer Flow Valve. Several models were also developed for the flow control loops which historically exhibited unreliable performance. The details of the valve flow models are given in Appendix 3 A.

[0096] In addition to the valve-flow model mismatch, there is an additional check to notify the operator in the event that a control valve is beyond controllable range using value-exceedance. Figure 41 shows both the components of the fuzzy network and an example of value-exceedance is shown in Figure 40

[0097] A time-varying drift term was added to the model estimate to compensate for long term sensor drift. The operator can also request a reset of the drift term after a sensor recalibration or when a manual bypass valve has been changed. This modification to the flow estimator significantly improved the robustness for implementation within an online detection algorithm.

[0098] The controller monitors (CM) and sensor checks (SC) were derived by analyzing the historical data and applying simple engineering calculations. The model for the CM was derived from calculation of the standard of deviation (SD) to detect a frozen instrument in the case the measurement experiences very low SD or a highly variant instrument when the measurement experiences high SD. Other calculations for CM include the accumulation of the length of time during which the measurement is not meeting and not criss-crossing the setpoint, and also the accumulation of the deviation between the measurement and the setpoint to detect the controller malfunction. The model for the SC was obtained by analyzing the historical data for the relationship between measurements. These are powerful checks as the condition of the controllers or the sensors are being directly monitored and compared to the models. The details of the

- 26 -

measurement correlation are given in Appendix 3 B. The abnormal monitor with drill down to the subproblem is shown in Figure 36. The components of the fuzzy network are shown in Figure 37.

[0099] The heuristic models (HM) are specific "operating rules-of-thumb" collected from experienced operators. These models identify those circumstances that violate these rules-of-thumb. An example is the monitoring of 801 granule area process variables to detect potential line plugging problems with the details given in Appendix 3 C. The abnormal monitor with drill down to the subproblem is shown in Figure 38. The components of the fuzzy network are shown in Figure 39.

Engineering Model & Heuristic Model Deployment

[00100] The procedure for implementing the engineering models within AED is fairly straightforward. For the computational models (e.g. VFM, CM and SC) the trigger points for notification were initially derived from the standard deviation of the model residual. For the heuristic models which identify specific known types of behavior within the unit (e.g. the Poly8 Cat, 801 Granule area, 831 Granule area, and Finishing 4 area operation), the trigger points for notification were determined from the analysis of historical data in combination with console operator input. For the first several months of operation, known AED indications were reviewed with the operator to ensure that the trigger points were appropriate and modified as necessary. Section "Deploying PCA Models and Simple Engineering Models for AED" in Appendix 1 describes details of engineering model deployment.

[00101] Under certain circumstances, the valve/flow diagnostics could provide the operator with redundant notification. Model suppression was applied to the valve / flow diagnostics to provide the operator with a single alert to a problem with a valve/flow pair.

C. AED Additional Tools

[00102] In order to facilitate smooth daily AED operation, various tools are provided to help maintain AED models and accommodate real concerns.

Event suppression/Tags Disabling

[00103] Under normal operations, the operator executes several routine actions (e.g., setpoint changes, tags under maintenance, and pump swaps). These moves could produce short-lived high residuals in some sensors. In practice if the AED models are not already aware of such changes, the result can be an abnormality signal. Since such notifications are redundant and do not give new information, this invention has mechanism built-in to detect their onset and suppress the event notifications. To temporarily suppress the event notification, a fuzzy net uses the condition checks to suppress the specified tags. In other situations, tags in PCA models, valve flow models and fuzzy nets can be temporarily disabled for specified time periods. In most cases, a reactivation time of 12 hours is used to prevent operators from forgetting to reactivate. If a tag has been removed from service for an extended period, it can also be disabled. In the case of PP routine operations, product grade switches are done very frequently. There are grade switches within a product grade family (called flying grade-switch) that do not require changes in reactor configuration. In this case, operators can make large setpoint changes to some key product-quality controllers to steer the PP to a new operation state. During the transitional state, some sensors will experience high residuals and therefore depict abnormal conditions. Modifications were made to the existing AED notification - suppression mechanism to handle the grade switches. The modifications include mechanism to detect the onset of a grade switch and set a grade -switch state. The grade switch state is then latched on for a certain period of time to depict a process transitional duration. During the transitional duration, the notifications are suppressed using the existing mechanism to avoid flooding

- 28 -

operators with nuisance alerts. However, during the transitional duration, AED continues to update PCA model parameters, and once the PP reaches its new steady state, AED resumes its notification. Figure 31 shows the fuzzy logic network for automatic detection of grade switches and for setting the transitional duration. There are also product grade switches requiring changes in reactor configuration (from two reactor mode to three reactor mode and vice versa). This modification of the AED notification suppression also handles the suppression for this case. The list of events currently suppressed is shown in Figure 43.

Logging Event Details

[00104] To derive the greatest benefits from such a system, it is necessary to train the operators and incorporate the AED system into the daily 'work process. Since the final authority still rests with the operator to take corrective actions, it is important to get their input on AED performance and enhancements. In order to capture AED event details in a systematic manner to review and provide feedback, the operators were provided with AED Event Forms. These helped maintain a record of events and help evaluate AED benefits. Since the time AED was commissioned, several critical events have been captured and documented for operations personnel. A sample form is shown in Figure 44.

Alternative Solutions May Be Better -Corrective actions for repeated events

[00105] If a particular repeating problem has been identified, the developer should confirm that there is not a better way to solve the problem. In particular the developer should make the following checks before trying to build an abnormal event detection application.

- Can the problem be permanently fixed? Often a problem exists because site personnel have not had sufficient time to investigate and permanently solve the problem. Once the

- 29 -

attention of the organization is focused on the problem, a permanent solution is often found. This is the best approach.

- Can the problem be directly measured? A more reliable way to detect a problem is to install sensors that can directly measure the problem in the process. This can also be used to prevent the problem through a process control application. This is the second best approach.
- Can an inferential measurement be developed which will measure the approach to the abnormal operation? Inferential measurements are very close relatives to PCA abnormal event models. If the data exists which can be used to reliably measure the approach to the problem condition (e.g. tower flooding using delta pressure), this can then be used to not only detect when the condition exists but also as the base for a control application to prevent the condition from occurring. This is the third best approach.

Abnormal Event Detection Applications Do Not Replace the Alarm System

[00106] Whenever a process problem occurs quickly, the alarm system will identify the problem as quickly as an abnormal event detection application. The sequence of events (e.g. the order in which measurements become unusual) may be more useful than the order of the alarms for helping the operator diagnose the cause. This possibility should be investigated once the application is on-line.

[00107] However, abnormal event detection applications can give the operator advanced warning when abnormal events develop slowly (longer than 15 minutes). These applications are sensitive to a change in the pattern of the process data rather than requiring a large excursion by a single variable. Consequently alarms can be avoided. If the alarm system has been configured to

- 30 -

alert the operator when the process moves away from a small operating region (not true safety alarms), this application may be able to replace these alarms.

[00108] In addition to just detecting the presence of an abnormal event the AED system also isolates the deviant sensors for the operator to investigate the event. This is a crucial advantage considering that modern plants have thousands of sensors and it is humanly infeasible to monitor them all online. The AED system can thus be thought of as another powerful addition to the operator toolkit to deal with abnormal situations efficiently and effectively.

APPENDIX 1

[00109] Events and disturbances of various magnitudes are constantly affecting process operations. Most of the time these events and disturbances are handled by the process control system. However, the operator is required to make an unplanned intervention in the process operations whenever the process control system cannot adequately handle the process event. We define this situation as an abnormal operation and the cause defined as an abnormal event.

[00110] A methodology and system has been developed to create and to deploy on-line, sets of models, which are used to detect abnormal operations and help the operator isolate the location of the root cause. In a preferred embodiment, the models employ principle component analysis (PCA). These sets of models are composed of both simple models that represent known engineering relationships and principal component analysis (PCA) models that represent normal data patterns that exist within historical databases. The results from these many model calculations are combined into a small number of summary time trends that allow the process operator to easily monitor whether the process is entering an abnormal operation.

[00111] Figure 1 shows how the information in the online system flows through the various transformations, model calculations, fuzzy Petri nets and consolidations to arrive at a summary trend which indicates the normality / abnormality of the process areas. The heart of this system is the various models used to monitor the normality of the process operations.

[00112] The PCA models described in this invention are intended to broadly monitor continuous refining and chemical processes and to rapidly detect developing equipment and process problems. The intent is to provide blanket monitoring of all the process equipment and process operations under the span of responsibility of a particular console operator post. This can involve many major refining or chemical process operating units (e.g. distillation towers,

- 32 -

reactors, compressors, heat exchange trains, etc.) which have hundreds to thousands of process measurements. The monitoring is designed to detect problems which develop on a minutes to hours timescale, as opposed to long term performance degradation. The process and equipment problems do not need to be specified beforehand. This is in contrast to the use of PCA models cited in the literature which are structured to detect a specific important process problem and to cover a much smaller portion of the process operations.

[00113] To accomplish this objective, the method for PCA model development and deployment includes a number of novel extensions required for their application to continuous refining and chemical processes including:

- criteria for establishing the equipment scope of the PCA models criteria and methods for selecting, analyzing, and transforming measurement inputs
- developing of multivariate statistical models based on a variation of principle component models, PCA
- developing models based on simple engineering relationships restructuring the associated statistical indices
- preprocessing the on-line data to provide exception calculations and continuous on-line model updating
- using fuzzy Petri nets to interpret model indices as normal or abnormal
- using fuzzy Petri nets to combine multiple model outputs into a single continuous summary indication of normality / abnormality for a process area
- design of operator interactions with the models and fuzzy Petri nets to reflect operations and maintenance activities

[00114] These extensions are necessary to handle the characteristics of continuous refining and chemical plant operations and the corresponding data characteristics so that PCA and simple engineering models can be used effectively. These extensions provide the advantage of preventing many of the Type I and Type II errors and quicker indications of abnormal events.

[00115] This section will not provide a general background to PCA. For that, readers should refer to a standard textbook such as E. Jackson's *"A User's Guide to Principal Component Analysis"* (2)

[00116] The classical PCA technique makes the following statistical assumptions, all of which are violated to some degree by the data generated from normal continuous refining and chemical plant process operations:

1. The process is stationary—its mean and variance are constant over time.
2. The cross correlation among variables is linear over the range of normal process operations
3. Process noise random variables are mutually independent.
4. The covariance matrix of the process variables is not degenerate (i.e. positive semi-definite).
5. The data are scaled "appropriately" (the standard statistical approach being to scale to unit variance).
6. There are no (uncompensated) process dynamics (a standard partial compensation for this being the inclusion of lag variables in the model)
7. All variables have some degree of cross correlation.
8. The data have a multivariate normal distribution

- 34 -

[00117] Consequently, in the selection, analysis and transformation of inputs and the subsequent in building the PCA model, various adjustments are made to evaluate and compensate for the degree of violation.

[00118] Once these PCA models are deployed on-line the model calculations require specific exception processing to remove the effect of known operation and maintenance activities, to disable failed or "bad acting" inputs, to allow the operator observe and acknowledge the propagation of an event through the process and to automatically restore the calculations once the process has returned to normal.

[00119] Use of PCA models is supplemented by simple redundancy checks that are based on known engineering relationships that must be true during normal operations. These can be as simple as checking physically redundant measurements, or as complex as material and engineering balances.

[00120] The simplest form of redundancy checks are simple 2x2 checks, e.g.

- temperature 1 = temperature 2
- flow 1 = valve characteristic curve 1 (valve 1 position)
- material flow into process unit 1 = material flow out of process unit 1

[00121] These are shown to the operator as simple x-y plots, such as the valve flow plot in Figure 2. Each plot has an area of normal operations, shown on this plot by the gray area. Operations outside this area are signaled as abnormal.

[00122] Multiple redundancy can also be checked through a single multidimensional model. Examples of multidimensional redundancy are:

- pressure 1 = pressure 2 = = pressure n
- material flow into process unit 1 = material flow out of process unit 1 = ... = material flow into process unit 2

- 35 -

[00123] Multidimensional checks are represented with "PCA like" models. In Figure 3, there are three independent and redundant measures, X1, X2, and X3. Whenever X3 changes by one, X1 changes by a_{13} and X2 changes by a_{23} . This set of relationships is expressed as a PCA model with a single principle component direction, P. This type of model is presented to the operator in a manner similar to the broad PCA models. As with the two dimensional redundancy checks the gray area shows the area of normal operations. The principle component loadings of P are directly calculated from the engineering equations, not in the traditional manner of determining P from the direction of greatest variability.

[00124] The characteristics of the process operation require exception operations to keep these relationships accurate over the normal range of process operations and normal field equipment changes and maintenance activities. Examples of exception operations are:

- opening of bypass valves around flow meters
- compensating for upstream / downstream pressure changes
- recalibration of field measurements
- redirecting process flows based on operating modes

[00125] The PCA models and the engineering redundancy checks are combined using fuzzy Petri nets to provide the process operator with a continuous summary indication of the normality of the process operations under his control (Figure 4).

[00126] Multiple statistical indices are created from each PCA model so that the indices correspond to the configuration and hierarchy of the process equipment that the process operator handles. The sensitivity of the traditional sum of Squared Prediction Error, SPE, index is improved by creating subset indices, which only contain the contribution to the SPE index for the inputs

- 36 -

which come from designated portions of the complete process area covered by the PCA model. Each statistical index from the PCA models is fed into a fuzzy Petri net to convert the index into a zero to one scale, which continuously indicates the range from normal operation (value of zero) to abnormal operation (value of one).

[00127] Each redundancy check is also converted to a continuous normal - abnormal indication using fuzzy nets. There are two different indices used for these models to indicate abnormality; deviation from the model and deviation outside the operating range (shown on Figure 3). These deviations are equivalent to the sum of the square of the error and the Hotelling T square indices for PCA models. For checks with dimension greater than two, it is possible to identify which input has a problem. In Figure 3, since the X3-X2 relationship is still within the normal envelope, the problem is with input X1. Each deviation measure is converted by the fuzzy Petri net into a zero to one scale that will continuously indicate the range from normal operation (value of zero) to abnormal operation (value of one).

[00128] For each process area under the authority of the operator, the applicable set of normal - abnormal indicators is combined into a single normal - abnormal indicator. This is done by using fuzzy Petri logic to select the worst case indication of abnormal operation. In this way the operator has a high level summary of all the checks within the process area. This section will not provide a general background to fuzzy Petri nets. For that, readers should refer to Cardoso, et al, *Fuzzy Petri Nets: An Overview (1)*

[00129] The overall process for developing an abnormal event application is shown in Figure 5. The basic development strategy is iterative where the developer starts with a rough model, then successively improves that model's capability based on observing how well the model represents the actual process

- 37 -

operations during both normal operations and abnormal operations. The models are then restructured and retrained based on these observations.

Developing PCA models for Abnormal Event Detection

I. Conceptual PCA Model Design

[00130] The overall design goals are to:

- provide the console operator with a continuous status (normal vs. abnormal) of process operations for all of the process units under his operating authority
- provide him with an early detection of a rapidly developing (minutes to hours) abnormal event within his operating authority
- provide him with only the key process information needed to diagnose the root cause of the abnormal event.

[00131] Actual root cause diagnosis is outside the scope of this invention. The console operator is expected to diagnosis the process problem based on his process knowledge and training.

[00132] Having a broad process scope is important to the overall success of abnormal operation monitoring. For the operator to learn the system and maintain his skills, he needs to regularly use the system. Since specific abnormal events occur infrequently, abnormal operations monitoring of a small portion of the process would be infrequently used by the operator, likely leading the operator to disregard the system when it finally detects an abnormal event. This broad scope is in contrast to the published modeling goal which is to design the model based on detecting a specific process problem of significant economic interest (see Kourti, 2004).

[00133] There are thousands of process measurements within the process units under a single console operator's operating authority. Continuous refining and chemical processes exhibit significant time dynamics among these

- 38 -

measurements, which break the cross correlation among the data. This requires dividing the process equipment into separate PCA models where the cross correlation can be maintained.

[00134] Conceptual model design is composed of four major decisions:

- Subdividing the process equipment into equipment groups with corresponding PCA models
- Subdividing process operating time periods into process operating modes requiring different PCA models
- Identifying which measurements within an equipment group should be designated as inputs to each PCA model
- Identifying which measurements within an equipment group should act as flags for suppressing known events or other exception operations

A. Process Unit Coverage

[00135] The initial decision is to create groups of equipment that will be covered by a single PCA model. The specific process units included requires an understanding of the process integration / interaction. Similar to the design of a multivariable constraint controller, the boundary of the PCA model should encompass all significant process interactions and key upstream and downstream indications of process changes and disturbances.

[00136] The following rules are used to determined these equipment groups:

[00137] *Equipment groups are defined by including all the major material and energy integrations and quick recycles in the same equipment group.* If the process uses a multivariable constraint controller, the controller model will explicitly identify the interaction points among the process units. Otherwise the interactions need to be identified through an engineering analysis of the process.

- 39 -

[00138] *Process groups should be divided at a point where there is a minimal interaction between the process equipment groups.* The most obvious dividing point occurs when the only interaction comes through a single pipe containing the feed to the next downstream unit. In this case the temperature, pressure, flow, and composition of the feed are the primary influences on the downstream equipment group and the pressure in the immediate downstream unit is the primary influence on the upstream equipment group. These primary influence measurements should be included in both the upstream and downstream equipment group PCA models.

[00139] *Include the influence of the process control applications between upstream and downstream equipment groups.* The process control applications provide additional influence paths between upstream and downstream equipment groups. Both feedforward and feedback paths can exist. Where such paths exist the measurements which drive these paths need to be included in both equipment groups. Analysis of the process control applications will indicate the major interactions among the process units.

[00140] *Divide equipment groups wherever there are significant time dynamics (e.g. storage tanks, long pipelines etc.).* The PCA models primarily handle quick process changes (e.g. those which occur over a period of minutes to hours). Influences, which take several hours, days or even weeks to have their effect on the process, are not suitable for PCA models. Where these influences are important to the normal data patterns, measurements of these effects need to be dynamically compensated to get their effect time synchronized with the other process measurements (see the discussion of dynamic compensation).

B. Process Operating Modes

[00141] *Process operating modes are defined as specific time periods where the process behavior is significantly different.* Examples of these are production of different grades of product (e.g. polymer production), significant process

- 40 -

transitions (e.g. startups, shutdowns, feedstock switches), processing of dramatically different feedstock (e.g. cracking naphtha rather than ethane in olefins production), or different configurations of the process equipment (different sets of process units running).

[00142] Where these significant operating modes exist, it is likely that separate PCA models will need to be developed for each major operating mode. The fewer models needed the better. The developer should assume that a specific PCA model could cover similar operating modes. This assumption must be tested by running new data from each operating mode through the model to see if it behaves correctly.

C. Historical Process Problems

[00143] In order for there to be organizational interest in developing an abnormal event detection system, there should be an historical process problem of significant economic impact. However, these significant problems must be analyzed to identify the best approach for attacking these problems. In particular, the developer should make the following checks before trying to build an abnormal event detection application:

1. Can the problem be permanently fixed? Often a problem exists because site personnel have not had sufficient time to investigate and permanently solve the problem. Once the attention of the organization is focused on the problem, a permanent solution is often found. This is the best approach.
2. Can the problem be directly measured? A more reliable way to detect a problem is to install sensors that can directly measure the problem in the process. This can also be used to prevent the problem through a process control application. This is the second best approach.
3. Can an inferential measurement be developed which will measure the approach to the abnormal operation? Inferential measurements are usually

- 41 -

developed using partial least squares, PLS, models which are very close relatives to PCA abnormal event models. Other common alternatives for developing inferential measurements include Neural Nets and linear regression models. If the data exists which can be used to reliably measure the approach to the problem condition (e.g. tower flooding using delta pressure), this can then be used to not only detect when the condition exists but also as the base for a control application to prevent the condition from occurring. This is the third best approach.

[00144] Both direct measurements of problem conditions and inferential measurements of these conditions can be easily integrated into the overall network of abnormal detection models.

II. Input Data and Operating Range Selection

[00145] Within an equipment group, there will be thousands of process measurements. For the preliminary design:

- Select all cascade secondary controller measurements, and especially ultimate secondary outputs (signals to field control valves) on these units
- Select key measurements used by the console operator to monitor the process (e.g. those which appear on his operating schematics)
- Select any measurements used by the contact engineer to measure the performance of the process
- Select any upstream measurement of feedrate, feed temperature or feed quality
- Select measurements of downstream conditions which affect the process operating area, particularly pressures.
- Select extra redundant measurements for measurements that are important

- 42 -

- Select measurements that may be needed to calculate non-linear transformations.
- Select any external measurement of a disturbance (e.g. ambient temperature)
- Select any other measurements, which the process experts regard as important measures of the process condition

[00146] From this list only include measurements which have the following characteristics:

- The measurement does not have a history of erratic or problem performance
- The measurement has a satisfactory signal to noise ratio
- The measurement is cross-correlated with other measurements in the data set
- The measurement is not saturated for more than 10% of the time during normal operations.
- The measurement is not tightly controlled to a fixed setpoint, which rarely changes (the ultimate primary of a control hierarchy).
- The measurement does not have long stretches of "Bad Value" operation or saturated against transmitter limits.
- The measurement does not go across a range of values, which is known to be highly non-linear
- The measurement is not a redundant calculation from the raw measurements
- The signals to field control valves are not saturated for more than 10% of the time

A. Evaluations for Selecting Model Inputs

[00147] There are two statistical criteria for prioritizing potential inputs into the PCA Abnormal Detection Model, Signal to Noise Ratio and Cross-Correlation.

1) Signal to Noise Test

The signal to noise ratio is a measure of the information content in the input signal.

The signal to noise ratio is calculated as follows:

1. The raw signal is filtered using an exponential filter with an approximate dynamic time constant equivalent to that of the process. For continuous refining and chemical processes this time constant is usually in the range of 30 minutes to 2 hours. Other low pass filters can be used as well. For the exponential filter the equations are:

$$Y_n = P * Y_{n-1} + (1-P) * X_n \quad \text{Exponential filter equation} \quad \text{Equation 1}$$

$$P = \text{Exp}(-T_s/T_f) \quad \text{Filter constant calculation} \quad \text{Equation 2}$$

where:

Y_n	the current filtered value
Y_{n-1}	the previous filtered value
X_n	the current raw value
P	the exponential filter constant
T_s	the sample time of the measurement
T_f	the filter time constant

2. A residual signal is created by subtracting the filtered signal from the raw signal

$$R_n = X_n - Y_n \quad \text{Equation 3}$$

- 44 -

3. The signal to noise ratio is the ratio of the standard deviation of the filtered signal divided by the standard deviation of the residual signal

$$S/N = \sigma_Y / \sigma_R \quad \text{Equation 4}$$

[00148] It is preferable to have all inputs exhibit a S/N which is greater than a predetermined minimum, such as 4. Those inputs with S/N less than this minimum need individual examination to determine whether they should be included in the model

[00149] The data set used to calculate the S/N should exclude any long periods of steady-state operation since that will cause the estimate for the noise content to be excessively large.

2) Cross Correlation Test

[00150] The cross correlation is a measure of the information redundancy the input data set. The cross correlation between any two signals is calculated as:

1. Calculate the co-variance, S_{ik} , between each input pair, i and k

$$S_{ik} = \frac{N * \sum (X_i * X_k) - (\sum X_i) * (\sum X_k)}{N * (N-1)} \quad \text{Equation 5}$$

2. Calculate the correlation coefficient for each pair of inputs from the co-variance:

$$CC_{ik} = S_{ik} / (S_{ii} * S_{kk})^{1/2} \quad \text{Equation 6}$$

[00151] There are two circumstances, which flag that an input should not be included in the model. The first circumstance occurs when there is no significant correlation between a particular input and the rest of the input data set. For each input, there must be at least one other input in the data set with a significant correlation coefficient, such as 0.4.

- 45 -

[00152] The second circumstance occurs when the same input information has been (accidentally) included twice, often through some calculation, which has a different identifier. Any input pairs that exhibit correlation coefficients near one (for example above 0.95) need individual examination to determine whether both inputs should be included in the model. If the inputs are physically independent but logically redundant (i.e., two independent thermocouples are independently measuring the same process temperature) then both these inputs should be included in the model.

[00153] If two inputs are transformations of each other (i.e., temperature and pressure compensated temperature) the preference is to include the measurement that the operator is familiar with, unless there is a significantly improved cross correlation between one of these measurements and the rest of the dataset. Then the one with the higher cross correlation should be included.

3) Identifying & Handling Saturated Variables

[00154] Refining and chemical processes often run against hard and soft constraints resulting in saturated values and "Bad Values" for the model inputs. Common constraints are: instrument transmitter high and low ranges, analyzer ranges, maximum and minimum control valve positions, and process control application output limits. Inputs can fall into several categories with regard to saturation which require special handling when pre-processing the inputs, both for model building and for the on-line use of these models.

[00155] For standard analog instruments (e.g., 4-20 milliamp electronic transmitters), bad values can occur because of two separate reasons:

- The actual process condition is outside the range of the field transmitter
- The connection with the field has been broken

[00156] When either of these conditions occur, the process control system could be configured on an individual measurement basis to either assign a special code to the value for that measurement to indicate that the measurement is a Bad Value, or to maintain the last good value of the measurement. These values will then propagate throughout any calculations performed on the process control system. When the "last good value" option has been configured, this can lead to erroneous calculations that are difficult to detect and exclude. Typically when the "Bad Value" code is propagated through the system, all calculations which depend on the bad measurement will be flagged bad as well.

[00157] Regardless of the option configured on the process control system, those time periods, which include Bad Values should not be included in training or test data sets. The developer needs to identify which option has been configured in the process control system and then configure data filters for excluding samples, which are Bad Values. For the on-line implementation, inputs must be pre-processed so that Bad Values are flagged as missing values, regardless of which option had been selected on the process control system.

[00158] Those inputs, which are normally Bad Value for extensive time periods should be excluded from the model.

[00159] Constrained variables are ones where the measurement is at some limit, and this measurement matches an actual process condition (as opposed to where the value has defaulted to the maximum or minimum limit of the transmitter range - covered in the Bad Value section). This process situation can occur for several reasons:

- Portions of the process are normally inactive except under special override conditions, for example pressure relief flow to the flare system. Time periods where these override conditions are active should be excluded from the training and validation

- 47 -

data set by setting up data filters. For the on-line implementation these override events are trigger events for automatic suppression of selected model statistics

- The process control system is designed to drive the process against process operating limits, for example product spec limits. These constraints typically fall into two categories: - those, which are occasionally saturated and those, which are normally saturated. Those inputs, which are normally saturated, should be excluded from the model. Those inputs, which are only occasionally saturated (for example less than 10% of the time) can be included in the model however, they should be scaled based on the time periods when they are not saturated.

B. Input from Process Control Applications

[00160] The process control applications have a very significant effect on the correlation structure of the process data. In particular:

- The variation of controlled variables is significantly reduced so that movement in the controlled variables is primarily noise except for those brief time periods when the process has been hit with a significant process disturbance or the operator has intentionally moved the operating point by changing key setpoints.
- The normal variation in the controlled variables is transferred by the control system to the manipulated variables (ultimately the signals sent to the control valves in the field).

[00161] The normal operations of refinery and chemical processes are usually controlled by two different types of control structures: the classical

- 48 -

control cascades (shown in Figure 6) and the more recent multivariable constraint controllers, MVCC (shown in Figure 7).

1) **Selecting model inputs from cascade structures**

[00162] Figure 6 shows a typical "cascade" process control application, which is a very common control structure for refining and chemical processes. Although there are many potential model inputs from such an application, the only ones that are candidates for the model are the raw process measurements (the "PVs" in this figure) and the final output to the field valve.

[00163] Although it is a very important measurement, the PV of the ultimate primary of the cascade control structure is a poor candidate for inclusion in the model. This measurement usually has very limited movement since the objective of the control structure is to keep this measurement at the setpoint. There can be movement in the PV of the ultimate primary if its setpoint is changed but this usually is infrequent. The data patterns from occasional primary setpoint moves will usually not have sufficient power in the training dataset for the model to characterize the data pattern.

[00164] Because of this difficulty in characterizing the data pattern resulting from changes in the setpoint of the ultimate primary, when the operator makes this setpoint move, it is likely to cause a significant increase in the sum of squared prediction error, SPE, index of the model. Consequently, any change in the setpoint of the ultimate primary is a candidate trigger for a "known event suppression". Whenever the operator changes an ultimate primary setpoint, the "known event suppression" logic will automatically remove its effect from the SPE calculation.

[00165] Should the developer include the PV of the ultimate primary into the model, this measurement should be scaled based on those brief time periods during which the operator has changed the setpoint and until the process has

- 49 -

moved close to the value of the new setpoint (for example within 95% of the new setpoint change thus if the setpoint change is from 10 to 11, when the PV reaches 10.95)

[00166] There may also be measurements that are very strongly correlated (for example greater than .95 correlation coefficient) with the PV of the Ultimate Primary, for example redundant thermocouples located near a temperature measurement used as a PV for an Ultimate Primary. These redundant measurements should be treated in the identical manner that is chosen for the PV of the Ultimate Primary.

[00167] Cascade structures can have setpoint limits on each secondary and can have output limits on the signal to the field control valve. It is important to check the status of these potentially constrained operations to see whether the measurement associated with a setpoint has been operated in a constrained manner or whether the signal to the field valve has been constrained. Data during these constrained operations should not be used.

2) Selecting / Calculating Model Inputs from Multivariable Constraint Controllers, MVCC

[00168] Figure 7 shows a typical MVCC process control application, which is a very common control structure for refining and chemical processes. An MVCC uses a dynamic mathematical model to predict how changes in manipulated variables, MVs, (usually valve positions or setpoints of regulatory control loops) will change control variables, CVs (the dependent temperatures, pressures, compositions and flows which measure the process state). An MVCC attempts to push the process operation against operating limits. These limits can be either MV limits or CV limits and are determined by an external optimizer. The number of limits that the process operates against will be equal to the number of MVs the controller is allowed to manipulate minus the number of material balances controlled. So if an MVCC has 12 MVs, 30 CVs and 2 levels

- 50 -

then the process will be operated against 10 limits. An MVCC will also predict the effect of measured load disturbances on the process and compensate for these load disturbances (known as feedforward variables, FF).

[00169] Whether or not a raw MV or CV is a good candidate for inclusion in the PCA model depends on the percentage of time that MV or CV is held against its operating limit by the MVCC. As discussed in the Constrained Variables section, raw variables that are constrained more than 10% of the time are poor candidates for inclusion in the PCA model. Normally unconstrained variables should be handled per the Constrained Variables section discussion.

[00170] If an unconstrained MV is a setpoint to a regulatory control loop, the setpoint should not be included; instead the measurement of that regulatory control loop should be included. The signal to the field valve from that regulatory control loop should also be included.

[00171] If an unconstrained MV is a signal to a field valve position, then it should be included in the model.

C. Redundant Measurements

[00172] The process control system databases can have a significant redundancy among the candidate inputs into the PCA model. One type of redundancy is "physical redundancy", where there are multiple sensors (such as thermocouples) located in close physical proximity to each other within the process equipment. The other type of redundancy is "calculational redundancy", where raw sensors are mathematically combined into new variables (e.g. pressure compensated temperatures or mass flows calculated from volumetric flow measurements).

[00173] As a general rule, both the raw measurement and an input which is calculated from that measurement should not be included in the model. The general preference is to include the version of the measurement that the process

- 51 -

operator is most familiar with. The exception to this rule is when the raw inputs must be mathematically transformed in order to improve the correlation structure of the data for the model. In that case the transformed variable should be included in the model but not the raw measurement.

[00174] Physical redundancy is very important for providing cross validation information in the model. As a general rule, raw measurements, which are physically redundant, should be included in the model. When there are a large number of physically redundant measurements, these measurements must be specially scaled so as to prevent them from overwhelming the selection of principle components (see the section on variable scaling). A common process example occurs from the large number of thermocouples that are placed in reactors to catch reactor runaways.

[00175] When mining a very large database, the developer can identify the redundant measurements by doing a cross-correlation calculation among all of the candidate inputs. Those measurement pairs with a very high cross-correlation (for example above .95) should be individually examined to classify each pair as either physically redundant or computationally redundant.

III. Historical Data Collection

[00176] A significant effort in the development lies in creating a good training data set, which is known to contain all modes of normal process operations. This data set should:

[00177] *Span the normal operating range:* Datasets, which span small parts of the operating range, are composed mostly of noise. The range of the data compared to the range of the data during steady state operations is a good indication of the quality of the information in the dataset.

[00178] *Include all normal operating modes (including seasonal mode variations).* Each operating mode may have different correlation structures.

- 52 -

Unless the patterns, which characterize the operating mode, are captured by the model, these unmodeled operating modes will appear as abnormal operations.

[00179] *Only include normal operating data: If strong abnormal operating data is included in the training data, the model will mistakenly model these abnormal operations as normal operations. Consequently, when the model is later compared to an abnormal operation, it may not detect the abnormality operations.*

[00180] *History should be as similar as possible to the data used in the on-line system: The online system will be providing spot values at a frequency fast enough to detect the abnormal event. For continuous refining and chemical operations this sampling frequency will be around one minute. Within the limitations of the data historian, the training data should be as equivalent to one-minute spot values as possible.*

[00181] The strategy for data collection is to start with a long operating history (usually in the range of 9 months to 18 months), then try to remove those time periods with obvious or documented abnormal events. By using such a long time period,

- the smaller abnormal events will not appear with sufficient strength in the training data set to significantly influence the model parameters
- most operating modes should have occurred and will be represented in the data.

A. Historical Data Collection Issues

1) Data Compression

[00182] Many historical databases use data compression to minimize the storage requirements for the data. Unfortunately, this practice can disrupt the correlation structure of the data. At the beginning of the project the data

- 53 -

compression of the database should be turned off and the spot values of the data historized. Final models should be built using uncompressed data whenever possible. Averaged values should not be used unless they are the only data available, and then with the shortest data average available.

2) Length of Data History

[00183] For the model to properly represent the normal process patterns, the training data set needs to have examples of all the normal operating modes, normal operating changes and changes and normal minor disturbances that the process experiences. This is accomplished by using data from over a long period of process operations (e.g. 9 - 18 months). In particular, the differences among seasonal operations (spring, summer, fall and winter) can be very significant with refinery and chemical processes.

[00184] Sometimes these long stretches of data are not yet available (e.g. after a turnaround or other significant reconfiguration of the process equipment). In these cases the model would start with a short initial set of training data (e.g. 6 weeks) then the training dataset is expanded as further data is collected and the model updated monthly until the models are stabilized (e.g. the model coefficients don't change with the addition of new data)

3) Ancillary Historical Data

[00185] The various operating journals for this time period should also be collected. This will be used to designate operating time periods as abnormal, or operating in some special mode that needs to be excluded from the training dataset. In particular, important historical abnormal events can be selected from these logs to act as test cases for the models.

- 54 -

4) Lack of Specific Measurement History

[00186] Often setpoints and controller outputs are not historized in the plant process data historian. Historization of these values should immediately begin at the start of the project.

5) Operating Modes

[00187] Old data that no longer properly represents the current process operations should be removed from the training data set. After a major process modification, the training data and PCA model may need to be rebuilt from scratch. If a particular type of operation is no longer being done, all data from that operation should be removed from the training data set.

[00188] Operating logs should be used to identify when the process was run under different operating modes. These different modes may require separate models. Where the model is intended to cover several operating modes, the number of samples in the training dataset from each operating model should be approximately equivalent.

6) Sampling Rate

[00189] The developer should gather several months of process data using the site's process historian, preferably getting one minute spot values. If this is not available, the highest resolution data, with the least amount of averaging should be used.

7) Infrequently Sampled Measurements

[00190] Quality measurements (analyzers and lab samples) have a much slower sample frequency than other process measurements, ranging from tens of minutes to daily. In order to include these measurements in the model a continuous estimate of these quality measurements needs to be constructed. Figure 8 shows the online calculation of a continuous quality estimate. This

- 55 -

same model structure should be created and applied to the historical data. This quality estimate then becomes the input into the PCA model.

8) Model Triggered Data Annotation

[00191] Except for very obvious abnormalities, the quality of historical data is difficult to determine. The inclusion of abnormal operating data can bias the model. The strategy of using large quantities of historical data will compensate to some degree the model bias caused by abnormal operating in the training data set. The model built from historical data that predates the start of the project must be regarded with suspicion as to its quality. The initial training dataset should be replaced with a dataset, which contains high quality annotations of the process conditions, which occur during the project life.

[00192] The model development strategy is to start with an initial "rough" model (the consequence of a questionable training data set) then use the model to trigger the gathering of a high quality training data set. As the model is used to monitor the process, annotations and data will be gathered on normal operations, special operations, and abnormal operations. Anytime the model flags an abnormal operation or an abnormal event is missed by the model, the cause and duration of the event is annotated. In this way feedback on the model's ability to monitor the process operation can be incorporated in the training data. This data is then used to improve the model, which is then used to continue to gather better quality training data. This process is repeated until the model is satisfactory.

IV. Data & Process Analysis

A. Initial Rough Data Analysis

[00193] Using the operating logs and examining the process key performance indicators, the historical data is divided into periods with known

- 56 -

abnormal operations and periods with no identified abnormal operations. The data with no identified abnormal operations will be the training data set.

[00194] Now each measurement needs to be examined over its history to see whether it is a candidate for the training data set. Measurements which should be excluded are:

- Those with many long periods of time as "Bad Value"
- Those with many long periods of time pegged to their transmitter high or low limits
- Those, which show very little variability (except those, which are tightly controlled to their setpoints)
- Those that continuously show very large variability relative to their operating range
- Those that show little or no cross correlation with any other measurements in the data set
- Those with poor signal to noise ratios

[00195] While examining the data, those time periods where measurements are briefly indicating "Bad Value" or are briefly pegged to their transmitter high or low limits should also be excluded.

[00196] Once these exclusions have been made the first rough PCA model should be built. Since this is going to be a very rough model the exact number of principal components to be retained is not important. This will typically be around 5% of the number measurements included in the model. The number of PCs should ultimately match the number of degrees of freedom in the process, however this is not usually known since this includes all the different sources of process disturbances. There are several standard methods for determining how

- 57 -

many principal components to include. Also at this stage the statistical approach to variable scaling should be used: scale all variables to unit variance.

$$X' = (X - X_{avg}) / \sigma \quad \text{Equation 7}$$

[00197] The training data set should now be run through this preliminary model to identify time periods where the data does not match the model. These time periods should be examined to see whether an abnormal event was occurring at the time. If this is judged to be the case, then these time periods should also be flagged as times with known abnormal events occurring. These time periods should be excluded from the training data set and the model rebuilt with the modified data.

B. Removing Outliers and Periods of Abnormal Operations

[00198] Eliminating obvious abnormal events will be done through the following:

Removing documented events. It is very rare to have a complete record of the abnormal event history at a site. However, significant operating problems should be documented in operating records such as operator logs, operator change journals, alarm journals, and instrument maintenance records. These are only providing a partial record of the abnormal event history.

Removing time periods where key performance indicators, KPIs, are abnormal. Such measurements as feed rates, product rates, product quality are common key performance indicators. Each process operation may have additional KPIs that are specific to the unit. Careful examination of this limited set of measurements will usually give a clear indication of periods of abnormal operations. Figure 9 shows a histogram of a KPI. Since the operating goal for this KPI is to maximize it, the operating periods where this KPI is low are likely abnormal operations. Process qualities are often the easiest KPIs to analyze since the optimum

- 58 -

operation is against a specification limit and they are less sensitive to normal feed rate variations.

C. Compensating for Noise

[00199] By noise we are referring to the high frequency content of the measurement signal which does not contain useful information about the process. Noise can be caused by specific process conditions such as two-phase flow across an orifice plate or turbulence in the level. Noise can be caused by electrical inductance. However, significant process variability, perhaps caused by process disturbances is useful information and should not be filtered out.

[00200] There are two primary noise types encountered in refining and chemical process measurements: measurement spikes and exponentially correlated continuous noise. With measurement spikes, the signal jumps by an unreasonably large amount for a short number of samples before returning to a value near its previous value. Noise spikes are removed using a traditional spike rejection filter such as the Union filter.

[00201] The amount of noise in the signal can be quantified by a measure known as the signal to noise ratio (see Figure 10). This is defined as the ratio of the amount of signal variability due to process variation to the amount of signal variability due to high frequency noise. A value below four is a typical value for indicating that the signal has substantial noise, and can harm the model's effectiveness.

[00202] Whenever the developer encounters a signal with significant noise, he needs to make one of three choices. In order of preference, these are:

- Fix the signal by removing the source of the noise (the best answer)
- Remove / minimize the noise through filtering techniques

- 59 -

- Exclude the signal from the model

[00203] Typically for signals with signal to noise ratios between 2 and 4, the exponentially correlated continuous noise can be removed with a traditional low pass filter such as an exponential filter. The equations for the exponential filter are:

$$Y^n = P * Y^{n-1} + (1-P) * X^n \quad \text{Exponential filter equation} \quad \text{Equation 8}$$

$$P = \text{Exp}(-T_s/T_f) \quad \text{Filter constant calculation} \quad \text{Equation 9}$$

Y^n is the current filtered value

Y^{n-1} is the previous filtered value

X^n is the current raw value

P is the exponential filter constant

T_s is the sample time of the measurement

T_f is the filter time constant

[00204] Signals with very poor signal to noise ratios (for example less than 2) may not be sufficiently improved by filtering techniques to be directly included in the model. If the input is regarded as important, the scaling of the variable should be set to de-sensitize the model by significantly increasing the size of the scaling factor (typically by a factor in the range of 2 - 10).

D. Transformed Variables

[00205] Transformed variables should be included in the model for two different reasons.

[00206] First, based on an engineering analysis of the specific equipment and process chemistry, known non-linearities in the process should be transformed and included in the model. Since one of the assumptions of PCA is that the variables in the model are linearly correlated, significant process or equipment non-linearities will break down this correlation structure and show up as a deviation from the model. This will affect the usable range of the model.

- 60 -

[00207] Examples of well known non-linear transforms are:

- Reflux to feed ratio in distillation columns
- Log of composition in high purity distillation
- Pressure compensated temperature measurement
- Sidestream yield
- Flow to valve position (Figure 2)
- Reaction rate to exponential temperature change

[00208] Second, the data from process problems, which have occurred historically, should also be examined to understand how these problems show up in the process measurements. For example, the relationship between tower delta pressure and feedrate is relatively linear until the flooding point is reached, when the delta pressure will increase exponentially. Since tower flooding is picked up by the break in this linear correlation, both delta pressure and feed rate should be included. As another example, catalyst flow problems can often be seen in the delta pressures in the transfer line. So instead of including the absolute pressure measurements in the model, the delta pressures should be calculated and included.

E. Dynamic Transformations

[00209] Figure 11 shows how the process dynamics can disrupt the correlation between the current values of two measurements. During the transition time one value is constantly changing while the other is not, so there is no correlation between the current values during the transition. However these two measurements can be brought back into time synchronization by transforming the leading variable using a dynamic transfer function. Usually a first order with deadtime dynamic model (shown in Equation 9 in the Laplace transform format) is sufficient to time synchronize the data.

- 61 -

$$Y'(s) = \frac{e^{-\Theta S} Y(s)}{T s + 1} \quad \text{Equation 9}$$

Y - raw data

Y' - time synchronized data

T - time constant

 Θ - deadtime

S - Laplace Transform parameter

[00210] This technique is only needed when there is a significant dynamic separation between variables used in the model. Usually only 1-2% of the variables requires this treatment. This will be true for those independent variables such as setpoints which are often changed in large steps by the operator and for the measurements which are significantly upstream of the main process units being modeled.

F. Removing Average Operating Point

[00211] Continuous refining and chemical processes are constantly being moved from one operating point to another. These can be intentional, where the operator or an optimization program makes changes to a key setpoints, or they can be due to slow process changes such as heat exchanger fouling or catalyst deactivation. Consequently, the raw data is not stationary. These operating point changes need to be removed to create a stationary dataset. Otherwise these changes erroneously appear as abnormal events.

[00212] The process measurements are transformed to deviation variables: deviation from a moving average operating point. This transformation to remove the average operating point is required when creating PCA models for abnormal event detection. This is done by subtracting the exponentially filtered value (see Equations 8 and 9 for exponential filter equations) of a measurement from its raw value and using this difference in the model.

- 62 -

$$X' = X - X_{\text{filtered}}$$

Equation 10

X' - measurement transformed to remove operating point changes

X - original raw measurement

X_{filtered} - exponentially filtered raw measurement

[00213] The time constant for the exponential filter should be about the same size as the major time constant of the process. Often a time constant of around 40 minutes will be adequate. The consequence of this transformation is that the inputs to the PCA model are a measurement of the recent change of the process from the moving average operating point.

[00214] In order to accurately perform this transform, the data should be gathered at the sample frequency that matches the on-line system, often every minute or faster. This will result in collecting 525,600 samples for each measurement to cover one year of operating data. Once this transformation has been calculated, the dataset is resampled to get down to a more manageable number of samples, typically in the range of 30,000 to 50,000 samples.

V. Model Creation

[00215] Once the specific measurements have been selected and the training data set has been built, the model can be built quickly using standard tools.

A. Scaling Model Inputs

[00216] The performance of PCA models is dependent on the scaling of the inputs. The traditional approach to scaling is to divide each input by its standard deviation, σ , within the training data set.

$$X_i' = X_i / \sigma_i$$

Equation 11

[00217] For input sets that contain a large number of nearly identical measurements (such as multiple temperature measurements of fixed catalyst

reactor beds) this approach is modified to further divide the measurement by the square root of the number of nearly identical measurements.

For redundant data groups

$$X_i' = X_i / (\sigma_i * \text{sqrt}(N)) \quad \text{Equation 12}$$

Where N = number of inputs in redundant data group

[00218] These traditional approaches can be inappropriate for measurements from continuous refining and chemical processes. Because the process is usually well controlled at specified operating points, the data distribution is a combination of data from steady state operations and data from "disturbed" and operating point change operations. These data will have overly small standard deviations from the preponderance of steady state operation data. The resulting PCA model will be excessively sensitive to small to moderate deviations in the process measurements.

[00219] For continuous refining and chemical processes, the scaling should be based on the degree of variability that occurs during normal process disturbances or during operating point changes not on the degree of variability that occurs during continuous steady state operations. For normally unconstrained variables, there are two different ways of determining the scaling factor.

[00220] First is to identify time periods where the process was not running at steady state, but was also not experiencing a significant abnormal event. A limited number of measurements act as the key indicators of steady state operations. These are typically the process key performance indicators and usually include the process feed rate, the product production rates and the product quality. These key measures are used to segment the operations into periods of normal steady state operations, normally disturbed operations, and abnormal operations. The standard deviation from the time periods of normally

- 64 -

disturbed operations provides a good scaling factor for most of the measurements.

[00221] An alternative approach to explicitly calculating the scaling based on disturbed operations is to use the entire training data set as follows. The scaling factor can be approximated by looking at the data distribution outside of 3 standard deviations from the mean. For example, 99.7% of the data should lie, within 3 standard deviations of the mean and that 99.99% of the data should lie, within 4 standard deviations of the mean. The span of data values between 99.7% and 99.99% from the mean can act as an approximation for the standard deviation of the "disturbed" data in the data set. See Figure 12.

[00222] Finally, if a measurement is often constrained (see the discussion on saturated variables) only those time periods where the variable is unconstrained should be used for calculating the standard deviation used as the scaling factor.

B. Selecting the Number of Principal Components

[00223] PCA transforms the actual process variables into a set of independent variables called Principal Components, PC, which are linear combinations of the original variables (Equation 13).

$$PC_i = A_{i,1} * X_1 + A_{i,2} * X_2 + A_{i,3} * X_3 + \dots \quad \text{Equation 13}$$

[00224] The process will have a number of degrees of freedom, which represent the specific independent effects that influence the process. These different independent effects show up in the process data as process variation. Process variation can be due to intentional changes, such as feed rate changes, or unintentional disturbances, such as ambient temperature variation.

[00225] Each principal component models a part of the process variability caused by these different independent influences on the process. The principal components are extracted in the direction of decreasing variation in the data set, with each subsequent principal component modeling less and less of the process

- 65 -

variability. Significant principal components represent a significant source of process variation, for example the first principal component usually represents the effect of feed rate changes since this is usually the source of the largest process changes. At some point, the developer must decide when the process variation modeled by the principal components no longer represents an independent source of process variation.

[00226] The engineering approach to selecting the correct number of principal components is to stop when the groups of variables, which are the primary contributors to the principal component no longer make engineering sense. The primary cause of the process variation modeled by a PC is identified by looking at the coefficients, $A_{i,n}$, of the original variables (which are called loadings). Those coefficients, which are relatively large in magnitude, are the major contributors to a particular PC. Someone with a good understanding of the process should be able to look at the group of variables, which are the major contributors to a PC and assign a name (e.g. feed rate effect) to that PC. As more and more PCs are extracted from the data, the coefficients become more equal in size. At this point the variation being modeled by a particular PC is primarily noise.

[00227] The traditional statistical method for determining when the PC is just modeling noise is to identify when the process variation being modeled with each new PC becomes constant. This is measured by the PRESS statistic, which plots the amount of variation modeled by each successive PC (Figure 13). Unfortunately this test is often ambiguous for PCA models developed on refining and chemical processes.

VI. Model Testing & Tuning

[00228] The process data will not have a gaussian or normal distribution. Consequently, the standard statistical method of setting the trigger for detecting an abnormal event at 3 standard deviations of the error residual should not be

- 66 -

used. Instead the trigger point needs to be set empirically based on experience with using the model.

[00229] Initially the trigger level should be set so that abnormal events would be signaled at a rate acceptable to the site engineer, typically 5 or 6 times each day. This can be determined by looking at the SPE_x statistic for the training data set (this is also referred to as the Q statistic or the $DMOD_x$ statistic). This level is set so that real abnormal events will not get missed but false alarms will not overwhelm the site engineer.

A. Enhancing the Model

[00230] Once the initial model has been created, it needs to be enhanced by creating a new training data set. This is done by using the model to monitor the process. Once the model indicates a potential abnormal situation, the engineer should investigate and classify the process situation. The engineer will find three different situations, either some special process operation is occurring, an actual abnormal situation is occurring, or the process is normal and it is a false indication.

[00231] The new training data set is made up of data from special operations and normal operations. The same analyses as were done to create the initial model need to be performed on the data, and the model re-calculated. With this new model the trigger lever will still be set empirically, but now with better annotated data, this trigger point can be tuned so as to only give an indication when a true abnormal event has occurred.

Simple Engineering Models for Abnormal Event Detection

[00232] The physics, chemistry, and mechanical design of the process equipment as well as the insertion of multiple similar measurements creates a substantial amount of redundancy in the data from continuous refining and chemical processes. This redundancy is called physical redundancy when

- 67 -

identical measurements are present, and calculational redundancy when the physical, chemical, or mechanical relationships are used to perform independent but equivalent estimates of a process condition. This class of model is called an engineering redundancy model.

I. Two Dimensional Engineering Redundancy Models

[00233] This is the simplest form of the model and it has the generic form:

$$F(y_i) = G(x_i) + \text{filtered bias}_i + \text{operator bias} + \text{error}_i \quad \text{Equation 14}$$

$$\text{raw bias}_i = F(y_i) - \{ G(x_i) + \text{filtered bias}_i + \text{operator bias} \} = \text{error}_i \quad \text{Equation 15}$$

$$\text{filtered bias}_i = \text{filtered bias}_{i-1} + N * \text{raw bias}_{i-1} \quad \text{Equation 16}$$

N - convergence factor (e.g. .0001)

Normal operating range: $x_{\min} < x < x_{\max}$

Normal model deviation: $-(\text{max_error}) < \text{error} < (\text{max_error})$

[00234] The "operator bias" term is updated whenever the operator determines that there has been some field event (e.g. opening a bypass flow) which requires the model to be shifted. On the operator's command, the operator bias term is updated so that Equation 14 is exactly satisfied ($\text{error}_i = 0$)

[00235] The "filtered bias" term updates continuously to account for persistent unmeasured process changes that bias the engineering redundancy model. The convergence factor, "N", is set to eliminate any persistent change after a user specified time period, usually on the time scale of days.

[00236] The "normal operating range" and the "normal model deviation" are determined from the historical data for the engineering redundancy model. In most cases the max_error value is a single value; however this can also be a vector of values that is dependent on the x axis location.

[00237] Any two dimensional equation can be represented in this manner. Material balances, energy balances, estimated analyzer readings versus actual

- 68 -

analyzer readings, compressor curves, etc. Figure 14 shows a two dimensional energy balance.

[00238] As a case in point the flow versus valve position model is explained in greater detail.

A. The Flow versus Valve Position Model

[00239] A particularly valuable engineering redundancy model is the flow versus valve position model. This model is graphically shown in Figure 2. The particular form of this model is:

$$\frac{\text{Flow}}{(\text{Delta_Pressure} / \text{Delta_Pressure}_{\text{reference}})^a} + \text{filtered bias} + \text{operator bias} = \text{Cv (VP)}$$

Equation 17

where:

Flow: measured flow through a control valve

Delta_Pressure = closest measured upstream pressure -
closest measured downstream pressure

Delta_Pressure_{reference} : average Delta_Pressure during normal operation

a : model parameter fitted to historical data

Cv: valve characteristic curve determined empirically from historical data

VP: signal to the control valve (not the actual control valve position)

The objectives of this model are to:

- Detecting sticking / stuck control valves
- Detecting frozen / failed flow measurements
- Detecting control valve operation where the control system loses control of the flow

[00240] This particular arrangement of the flow versus valve equation is chosen for human factors reasons: the x-y plot of the equation in this form is the

- 69 -

one most easily understood by the operators. It is important for any of these models that they be arranged in the way which is most likely to be easily understood by the operators.

B. Developing the Flow versus Valve Position Model

[00241] Because of the long periods of steady state operation experienced by continuous refining and chemical processes, a long historical record (1 to 2 years) may be required to get sufficient data to span the operation of the control valve. Figure 15 shows a typical stretch of Flow, Valve Position, and Delta Pressure data with the long periods of constant operation. The first step is to isolate the brief time periods where there is some significant variation in the operation, as shown. This should be then mixed with periods of normal operation taken from various periods in history.

[00242] Often, either the Upstream_Pressure (often a pump discharge) or the Downstream_Pressure is not available. In those cases the missing measurement becomes a fixed model parameter in the model. If both pressures are missing then it is impossible to include the pressure effect in the model.

[00243] The valve characteristic curve can be either fit with a linear valve curve, with a quadratic valve curve or with a piecewise linear function. The piecewise linear function is the most flexible and will fit any form of valve characteristic curve.

[00244] The theoretical value for "a" is 1/2 if the measurements are taken directly across the valve. Rarely are the measurements positioned there. "a" becomes an empirically determined parameter to account for the actual positioning of the pressure measurements.

[00245] Often there will be very few periods of time with variations in the Delta_Pressure. The noise in the Delta_Pressure during the normal periods of operation can confuse the model-fitting program. To overcome this, the model

- 70 -

is developed in two phases, first where a small dataset, which only contains periods of Delta_Pressure variation is used to fit the model. Then the pressure dependent parameters ("a" and perhaps the missing upstream or downstream pressure) are fixed at the values determined, and the model is re-developed with the larger dataset.

C. Fuzzy-net Processing of Flow versus Valve Abnormality Indications

[00246] As with any two-dimensional engineering redundancy model, there are two measures of abnormality, the "normal operating range" and the "normal model deviation". The "normal model deviation" is based on a normalized index: the error / max_error. This is fed into a type 4 fuzzy discriminator (Figure 16). The developer can pick the transition from normal (value of zero) to abnormal (value of 1) in a standard way by using the normalized index.

[00247] The "normal operating range" index is the valve position distance from the normal region. It typically represents the operating region of the valve where a change in valve position will result in little or no change in the flow through the valve. Once again the developer can use the type 4 fuzzy discriminator to cover both the upper and lower ends of the normal operating range and the transition from normal to abnormal operation.

D. Grouping Multiple Flow / Valve Models

[00248] A common way of grouping Flow / Valve models which is favored by the operators is to put all of these models into a single fuzzy network so that the trend indicator will tell them that all of their critical flow controllers are working. In that case, the model indications into the fuzzy network (Figure 4) will contain the "normal operating range" and the "normal model deviation" indication for each of the flow/valve models. The trend will contain the discriminator result from the worst model indication.

- 71 -

[00249] When a common equipment type is grouped together, another operator favored way to look at this group is through a Pareto chart of the flow / valves (Figure 17). In this chart, the top 10 abnormal valves are dynamically arranged from the most abnormal on the left to the least abnormal on the right. Each Pareto bar also has a reference box indicating the degree of variation of the model abnormality indication that is within normal. The chart in Figure 17 shows that "Valve 10" is substantially outside the normal box but that the others are all behaving normally. The operator would next investigate a plot for "Valve 10" similar to Figure 2 to diagnose the problem with the flow control loop.

II. Multidimensional Engineering Redundancy Models

[00250] Once the dimensionality gets larger than 2, a single "PCA like" model is developed to handle a high dimension engineering redundancy check. Examples of multidimensional redundancy are:

- pressure 1 = pressure 2 = = pressure n
- material flow into process unit 1 = material flow out of process unit 1 = ... = material flow into process unit 2

[00251] Because of measurement calibration errors, these equations will each require coefficients to compensate. Consequently, the model set that must be first developed is:

$$\begin{aligned} F_1(y_i) &= a_1 G_1(x_i) + \text{filtered bias}_{1,i} + \text{operator bias}_1 + \text{error}_{1,i} \\ F_2(y_i) &= a_n G_2(x_i) + \text{filtered bias}_{2,i} + \text{operator bias}_2 + \text{error}_{2,i} \\ F_n(y_i) &= a_n G_n(x_i) + \text{filtered bias}_{n,i} + \text{operator bias}_n + \text{error}_{n,i} \end{aligned}$$

Equation 18

[00252] These models are developed in the identical manner that the two dimensional engineering redundancy models were developed.

[00253] This set of multidimensional checks are now converted into "PCA like" models. This conversion relies on the interpretation of a principle

- 72 -

component in a PCA model as a model of an independent effect on the process where the principle component coefficients (loadings) represent the proportional change in the measurements due to this independent effect. In Figure 3, there are three independent and redundant measures, X1, X2, and X3. Whenever X3 changes by one, X1 changes by a_1 and X2 changes by a_2 . This set of relationships is expressed as a single principle component model, P, with coefficients in unscaled engineering units as:

$$P = a_1 X_1 + a_2 X_2 + a_3 X_3 \quad \text{Equation 19}$$

Where $a_3 = 1$

[00254] This engineering unit version of the model can be converted to a standard PCA model format as follows:

[00255] Drawing analogies to standard statistical concepts, the conversion factors for each dimension, X, can be based on the normal operating range. For example, using 3σ around the mean to define the normal operating range, the scaled variables are defined as:

$$X_{\text{scale}} = X_{\text{normal operating range}} / 6\sigma \quad \text{Equation 20}$$

(99.7% of normal operating data should fall within 3σ of the mean)

$$X_{\text{mid}} = X_{\text{mid point of operating range}} \quad \text{Equation 21}$$

(explicitly defining the "mean" as the mid point of the normal operating range)

$$X' = (X - X_{\text{mid}}) / X_{\text{scale}} \quad \text{Equation 22}$$

(standard PCA scaling once mean and σ are determined)

Then the P' loadings for X_i are:

$$b_i = (a_i / X_{i\text{-scale}}) / \left(\sum_{k=1}^N (a_k / X_{k\text{-scale}})^2 \right)^{1/2} \quad \text{Equation 23}$$

(the requirement that the loading vector be normalized)

This transforms P to

$$P' = b_1 * X1 + b_2 * X2 + \dots + b_n * XN \quad \text{Equation 24}$$

$$P' \text{ "standard deviation"} = b_1 + b_2 + \dots + b_n \quad \text{Equation 25}$$

[00256] With this conversion, the multidimensional engineering redundancy model can now be handled using the standard PCA structure for calculation, exception handling, operator display and interaction.

Deploying PCA models and Simple Engineering Models for Abnormal Event Detection

I. Operator and Known Event Suppression

[00257] Suppression logic is required for the following:

- Provide a way to eliminate false indications from measurable unusual events
- Provide a way to clear abnormal indications that the operator has investigated
- Provide a way to temporarily disable models or measurements for maintenance
- Provide a way to disable bad acting models until they can be retuned
- Provide a way to permanently disable bad acting instruments.

[00258] There are two types of suppression. Suppression which is automatically triggered by an external, measurable event and suppression which is initiated by the operator. The logic behind these two types of suppression is shown in Figures 18 and 19. Although these diagrams show the suppression occurring on a fuzzified model index, suppression can occur on a particular

- 74 -

measurement, on a particular model index, on an entire model, or on a combination of models within the process area.

[00259] For operator initiated suppression, there are two timers, which determine when the suppression is over. One timer verifies that the suppressed information has returned to and remains in the normal state. Typical values for this timer are from 15 - 30 minutes. The second timer will reactivate the abnormal event check, regardless of whether it has returned to the normal state. Typical values for this timer are either equivalent to the length of the operator's work shift (8 to 12 hours) or a very large time for semi-permanent suppression.

[00260] For event based suppression, a measurable trigger is required. This can be an operator setpoint change, a sudden measurement change, or a digital signal. This signal is converted into a timing signal, shown in Figure 20. This timing signal is created from the trigger signal using the following equations:

$$Y_n = P * Y_{n-1} + (1-P) * X_n \quad \text{Exponential filter equation} \quad \text{Equation 26}$$

$$P = \text{Exp}(-T_s/T_f) \quad \text{Filter constant calculation} \quad \text{Equation 27}$$

$$Z_n = X_n - Y_n \quad \text{Timing signal calculation} \quad \text{Equation 28}$$

where:

- Y_n the current filtered value of the trigger signal
- Y_{n-1} the previous filtered value of the trigger signal
- X_n the current value of the trigger signal
- Z_n the timing signal shown in Figure 20
- P the exponential filter constant
- T_s the sample time of the measurement
- T_f the filter time constant

[00261] As long as the timing signal is above a threshold (shown as .05 in Figure 20), the event remains suppressed. The developer sets the length of the

- 75 -

suppression by changing the filter time constant, T_f . Although a simple timer could also be used for this function, this timing signal will account for trigger signals of different sizes, creating longer suppressions for large changes and shorter suppressions for smaller changes.

[00262] Figure 21 shows the event suppression and the operator suppression disabling predefined sets of inputs in the PCA model. The set of inputs to be automatically suppressed is determined from the on-line model performance. Whenever the PCA model gives an indication that the operator does not want to see, this indication can be traced to a small number of individual contributions to the Sum of Error Square index. To suppress these individual contributions, the calculation of this index is modified as follows:

$$E^2 = \sum_{i=1}^n w_i e_i^2 \quad \text{Equation 29}$$

w_i - the contribution weight for input i (normally equal to 1)

e_i - the contribution to the sum of error squared from input i

[00263] When a trigger event occurs, the contribution weights are set to zero for each of the inputs that are to be suppressed. When these inputs are to be reactivated, the contribution weight is gradually returned to a value of 1.

II. PCA Model Decomposition

[00264] Although the PCA model is built using a broad process equipment scope, the model indices can be segregated into groupings that better match the operators' view of the process and can improve the sensitivity of the index to an abnormal event.

[00265] Referring again to Equation 29, we can create several Sum of Error Square groupings:

$$E_1^2 = \sum_{i=1}^l w_i e_i^2 \quad \text{Equation 30}$$

$$E_2^2 = \sum_{i=1}^k w_i e_i^2$$

$$\vdots$$

- 76 -

$$E_m^2 = \sum_{i=k}^n w_i e_i^2$$

[00266] Usually these groupings are based around smaller sub-units of equipment (e.g. reboiler section of a tower), or are sub-groupings, which are relevant to the function of the equipment (e.g. product quality).

[00267] Since each contributor, e_i , is always adding to the sum of error square based on process noise, the size of the index due to noise increases linearly with the number of inputs contributing to the index. With fewer contributors to the sum of error square calculation, the signal to noise ratio for the index is improved, making the index more responsive to abnormal events.

[00268] In a similar manner, each principle component can be subdivided to match the equipment groupings and an index analogous to the Hotelling T^2 index can be created for each subgroup.

$$P_{1,a} = \sum_{i=1}^l b_{1,i} X_i \quad \text{Equation 31}$$

$$P_{1,b} = \sum_{i=l}^k b_{1,i} X_i$$

$$P_{1,c} = \sum_{i=k}^n b_{1,i} X_i$$

$$P_{2,a} = \sum_{i=1}^l b_{2,i} X_i$$

$$P_{2,b} = \sum_{i=l}^k b_{2,i} X_i$$

$$P_{2,c} = \sum_{i=k}^n b_{2,i} X_i$$

$$T_a^2 = \sum_{i=1}^m P_{i,a}^2$$

$$T_b^2 = \sum_{i=1}^m P_{i,b}^2$$

$$T_c^2 = \sum_{i=1}^m P_{i,c}^2$$

[00269] The thresholds for these indices are calculated by running the testing data through the models and setting the sensitivity of the thresholds based on their performance on the test data.

- 77 -

[00270] These new indices are interpreted for the operator in the identical manner that a normal PCA model is handled. Pareto charts based on the original inputs are shown for the largest contributors to the sum of error square index, and the largest contributors to the largest P in the T^2 calculation.

III. Overlapping PCA models

[00271] Inputs will appear in several PCA models so that all interactions affecting the model are encompassed within the model. This can cause multiple indications to the operator when these inputs are the major contributors to the sum of error squared index.

[00272] To avoid this issue, any input, which appears in multiple PCA models, is assigned one of those PCA models as its primary model. The contribution weight in Equation 29 for the primary PCA model will remain at one while for the non-primary PCA models, it is set to zero.

IV. Operator Interaction & Interface Design

[00273] The primary objectives of the operator interface are to:

- Provide a continuous indication of the normality of the major process areas under the authority of the operator
- Provide rapid (1 or 2 mouse clicks) navigation to the underlying model information
- Provide the operator with control over which models are enabled. Figure 22 shows how these design objectives are expressed in the primary interfaces used by the operator.

[00274] The final output from a fuzzy Petri net is a normality trend as is shown in Figure 4. This trend represents the model index that indicates the greatest likelihood of abnormality as defined in the fuzzy discriminate function. The number of trends shown in the summary is flexible and decided in

- 78 -

discussions with the operators. On this trend are two reference lines for the operator to help signal when they should take action, a yellow line typically set at a value of 0.6 and a red line typically set at a value of 0.9. These lines provide guidance to the operator as to when he is expected to take action. When the trend crosses the yellow line, the green triangle in Figure 4 will turn yellow and when the trend crosses the red line, the green triangle will turn red. The triangle also has the function that it will take the operator to the display associated with the model giving the most abnormal indication.

[00275] If the model is a PCA model or it is part of an equipment group (e.g. all control valves), selecting the green triangle will create a Pareto chart. For a PCA model, of the dozen largest contributors to the model index, this will indicate the most abnormal (on the left) to the least abnormal (on the right). Usually the key abnormal event indicators will be among the first 2 or 3 measurements. The Pareto chart includes a red box around each bar to provide the operator with a reference as to how unusual the measurement can be before it is regarded as an indication of abnormality.

[00276] For PCA models, operators are provided with a trend Pareto, which matches the order in the bar chart Pareto. With the trend Pareto, each plot has two trends, the actual measurement (in cyan) and an estimate from the PCA model of what that measurements should have been if everything was normal (in tan).

[00277] For valve / flow models, the detail under the Pareto will be the two dimensional flow versus valve position model plot. From this plot the operator can apply the operator bias to the model.

[00278] If there is no equipment grouping, selecting the green triangle will take the operator right to the worst two-dimensional model under the summary trend.

- 79 -

[00279] Operator suppression is done at the Pareto chart level by selecting the on/off button beneath each bar.

BIBLIOGRAPHY***I. U.S. Patent Documents***

1	5,859,964	1/12/99	Wang, et al, "System and method for performing real time data acquisition, process modeling and fault detection of wafer fabrication processes"
2	5,949,678	9/7/99	Wold, et al, "Method for Monitoring Multivariable Processes"
3	6,522,978	2/18/02	Chen, et al, "Paper web breakage prediction using principal components analysis and classification and regression trees"
4	6,368,975	4/9/02	Balasubramhanya, et al, "Method and apparatus for monitoring a process by employing principal component analysis"
5	6,466,877	10/15/02	Chen, et al, "Paper web breakage prediction using principal components analysis and classification and regression trees"
6	6,521,080	2/18/03	Balasubramhanya, et al, "Method and apparatus for monitoring a process by employing principal component analysis"
7	6,564,119	5/13/03	Vaculik, et al, "Multivariate Statistical Model Based System for Monitoring the Operation of a Continuous Caster and Detecting the Onset of Impending Breakouts"
8	6,636,842	10/21/03	Zambrano, et al, "System and method for controlling an industrial process utilizing process trajectories"

II. Literature

1.	Cardoso, J. et al	"Fuzzy Petri Nets : An Overview", 13 th Word Congress of IFAC, Vol. I : Identification II, Discrete Event Systems, San Francisco, CA, USA, June 30 - July 5, 1996, pp. 443-448.
2.	Jackson, E.	" A User's Guide to Principal Component Analysis ", John Wiley & Sons, 1991
3.	Kourti, T.	"Process Analysis and Abnormal Situation Detection: From Theory to Practice", IEEE Control Systems Magazine, Oct. 2002, pp. 10 - 25
4.	Ku, W.	"Disturbance Detection and Isolation for Statistical Process Control in Chemical Processes", PhD Thesis, Lehigh University, August 17, 1994
5.	Martens, H., & Naes, T.,	"Multivariate Calibration", John Wiley & Sons, 1989
6.	Piovoso, M.J., et al.	"Process Data Chemometrics", IEEE Trans on Instrumentation and Measurement, Vol. 41, No. 2, April 1992, pp. 262 - 268

- 81 -

APPENDIX 2**Principal Component Analysis Models****APPENDIX 2 A****The POLY8_TCR PCA Model: 10 Principal Components (PC)****With Sensor Description and Engineering Units**

<u>PC</u>	<u>Tag Description</u>	<u>Eng. Unit</u>
P1	Co-Catalyst Flow	LB/HR
	RX1 COOL H2O DELTA T	DEGF
	C3= Feed to Reactors	KLB/HR
	RX LOOPS PRODUCTION CNTL	KLB/HR
P2	Co-Catalyst Flow	LB/HR
	C3 Pump outlet temp.	DEGF
	C3 Supply LIQ OUT TEMP	DEGF
	Pre-RX1 Pump C3= FLUSH	DEGF
	RX1 BDL HDR TEMP	DEGF
P3	Recycle Tower1 GAS OUT TEMP	DEGF
	RX1 BTM TEMPLEG 3	DEGF
	RX1 BTM TEMP LEG 2	DEGF
	RX1 BTM TEMPLEG 4	DEGF
	RX1 BTM TEMP LEG 1	DEGF
P4	RX2 BTM TEMPLEG 3	DEGF
	Steam Drum BOOT LEVEL	PCT
	Recycle Tower1 BTMS TEMP	DEGF
	Recycle Compressor STAGE 3 DISCHRG	PSIG
	Rx1 & 2 OVHD Drum C3= Level Backup	PCT
P5	Rx1 & 2 OVHD Drum C3= Level	PCT
	Overhead Drum VAPOR TO BDL	PSIG
	RX2 PRESSURE OVRD CTRL	PSIG
	Pre-RX1 REACTOR PRESSURE	PSIG
	RX1 PRESSURE LEG 4	PSIG
P6	RX2 SLURRY DENSITY	LB/CF
	Cat Pump Stroke CTRL	PCT
	CAT FLOW CTRL	LB/HR
	CAT FLOW CTRL	LB/HR
	LOW RANGE H2 TO RX1	LB/HR
P7	LOW RANGE H2 TO RX2	PCT
	Propane Concentration in C3= Feed	MOLPCT
	Recycle Gas H2 Concentration	MOLPPM
	LOW RANGE H2 TO RX1	LB/HR
	HYDROGEN TO RX1	LB/HR
	Recycle gas flow Control Valve	PCT

- 82 -

P8	Recycle Compressor STAGE 1 DISCHRG	DEGF
	Recycle Compressor STAGE 3 DISCHRG	DEGF
	Recycle Compressor STAGE 1 DISCHRG	PSIG
	Recycle Compressor STAGE 2 DISCHRG	PSIG
	Recycle Compressor STAGE 2 DISCHRG	DEGF
P9	Recycle GAS OUT TEMP	DEGF
	Recycle Tower1 BOTTOM LEVEL	PCT
	STEAM PRESS	PSIG
	Dust Collector BTMS TEMP	DEGF
	Recycle Tower1 REFLUX CONTROL	KLB/HR
P10	Recycle Tower1 FEED FRM D-8122	PSIG
	Dust Collector BTMS TEMP	DEGF
	Recycle GAS OUT TEMP	DEGF
	Recycle Compressor STAGE 1 DISCHRG	DEGF
	Recycle Compressor MOTOR AMPS	AMP

- 83 -

APPENDIX 2 B:**The POLY8_ICP PCA Model: 12 Principal Components**

With Sensor Description and Engineering Units

<u>PC</u>	<u>Tag Description</u>	<u>Eng. Unit</u>
P1	Co-Catalyst flow	LB/HR
	Monomer (C3=) TO RX1 Cooler	KLB/HR
	RX1 JKT H2O OUTLET	DEGF
	Pre-RX1 JKT H2O INLET	DEGF
	Catalyst flow	LB/HR
P2	RX3 Gas Compressor MOTOR AMPS	AMP
	RX3 TOP PRESS	PSIG
	Rx3 Cooler PURGE TO RX3	PSIG
	RX3 TOP PRESS	PSIG
	N2 Suppy PRESS	PSIG
P3	C3= Supply Temp	DEGF
	C3 Pump outlet temp.	DEGF
	Recycle Tower1 GAS OUT TEMP	DEGF
	Pre-RX1 C3= FLUSH	DEGF
	Recycle C3= OUTLET TEMP CTL	PCT
P4	C3 Pump outlet temp.	DEGF
	C3= Supply Temp	DEGF
	Pre-Rx1 Pump C3= FLUSH	DEGF
	Pre-RX1 LOWER TEMP 1	DEGF
	RX1 BDL HDR TEMP	DEGF
P5	Overhead Drum VAPOR TO BDL	PSIG
	RX2 PRESSURE OVRD CTRL	PSIG
	Pre-RX1 REACTOR PRESSURE	PSIG
	RX1 PRESSURE LEG 4	PSIG
	Pre-RX1 CHILLED H2O M/U	PCT
P6	Recycle Tower2 TRAY 12 TEMP	DEGF
	Recycle Tower2 TO RX3 Gas Compressor	KLB/HR
	Recycle Compressor STAGE 3 DISCHRG	PSIG
	Recycle Tower2 TRAY 23 TEMP	DEGF
	Recycle Tower2 PRESSURE CONTROL	PSIG
P7	RX3 Cooler H2O OUT TEMP	DEGF
	Recycle Tower2 OVHD VAPTEMP	DEGF
	C3= Feed to RX3	KLB/HR
	RX3 Cooler CHILLED H2O FLOW	PCT
	Recycle Tower2 OVHD C2=	MOLPCT

P8	C3= Suppy Press	PSIG
	RX1 Pump C3= SEAL FLUSH	KLB/HR
	Rx1 & 2 OVHD Drum C3= Level	PCT
	Rx1 & 2 OVHD Drum C3= Level Backup	PCT
	RX2 Pump C3= SEAL FLUSH	KLB/HR
P9	Recycle Tower2 VENT FLOW	KLB/HR
	Recycle Tower2 VENT FLOW CONTROL	PCT
	RX3 OVHD H2	MOLPCT
	RX2 BTM TEMPLEG 3	DEGF
	RX2 BTM TEMPLEG 4	DEGF
P10	RX2 BTM TEMPLEG 4	DEGF
	RX2 BTM TEMPLEG 3	DEGF
	RX2 BTM TEMP LEG 2	DEGF
	RX2 BTM TEMP LEG 1	DEGF
	RX2 SLURRY DENSITY	LB/CF
P11	C3= Suppy Pressure	PSIG
	Recycle GAS OUT TEMP	DEGF
	C3= Suppy Pressure control	PSIG
	C3= Flow to the Reactors	PCT
	Granule OUT TEMP	DEGF
P12	Recycle Tower1 BOTTOM LEVEL	PCT
	Granule OUT TEMP	DEGF
	Recycle GAS OUT TEMP	DEGF
	Stripper Steam Press	PSIG
	Recycle Tower1 REFLUX CONTROL	KLB/HR

- 85 -

APPENDIX 2 C**The Dryers8 PCA Model****With Sensor Description, Engineering Units**

<u>Tag Description</u>	<u>Eng. Unit</u>
Dryer PRESSURE	PSIG
N2 In 1 To Dryer	DEGF
N2 In 2 To Dryer	DEGF
Dryer Vapor Outlet TEMP	DEGF
DR MOTOR AMPS	AMP
MA-8751 MOTOR AMPS	AMP
Dryer STEAM FLOW	PCT
Dryer STEAM FLOW	LB/HR
Dryer STM FLOW CONTROL	PCT
Dryer STM FLOW CONTROL	LB/HR
Dryer WET N2 FLOW CTL	PCT
Dryer WET N2 FLOW CTL	LB/HR
Dryer Dry N2 FLOW CTL	PCT
Dryer Dry N2 FLOW CTL	LB/HR
Discharge Flow to Fuel Gas System	KLB/HR
Calculated Dryer Granule Flow	PCT
Accum Drum 1 LEVEL Output	PCT
Accum Drum 1 LEVEL	PCT
Accum Drum 2 LEVEL	PCT
Dryer STEAM PRESSURE	PSIG
Dryer PRESSURE CONTROL	PSIG
Dust Collector DELTA PRESS	INH2O
N2 Filter DELTA PRESS	PSI
Compressor SUCTION PRESSURE	PSIG
Transfer System SUCTION PRESSURE	PSIG
Transfer System DISCHARGE PRESS	PSIG
Dryer FUEL GAS HDR	PSIG
Dryer Pressure	PSIG
C-8754 DISCHARGE PRESS	PSIG
Dryer Motor1 SPEED	RPM
Dryer Motor2 SPEED	RPM
Dryer BOTTOMS TEMP	DEGF
C-8754 DISCHRG TEMP	DEGF
Dryer Granule DISCHRG TEMP	DEGF
Dryer GRANULESTEMP	DEGF
Dryer GRANULES OUT TEMP	DEGF
D-8757 TO FUEL GAS HDR	DEGF

- 86 -

APPENDIX 2 D**The EX801 PCA Model****With Sensor Description, Engineering Units**

<u>Tag Description</u>	<u>Eng. Unit</u>
EX MAIN MOTOR POWER	KW
EX PELLETIZER KWS	KW
EX Feed	LB/HR
EX N2 INJ FLOW CTL	PCT
EX N2 INJ FLOW CTL	SCFH
EX HEAD PRESSURE	PSIG
EX DIE HOUSE PRESSURE	PSIG
EX BARREL 2 COOL CTRL	DEGF
EX BARREL 3 COOL CTRL	PCT
EX BARREL 3 COOL CTRL	DEGF
EX BARREL 4 COOL CTRL	PCT
EX BARREL 4 COOL CTRL	DEGF
EX BARREL 5 COOL CTRL	DEGF
EX BARREL 6 COOL CTRL	DEGF
EX BARREL 7 COOL CTRL	PCT
EX BARREL 7 COOL CTRL	DEGF
EX BARREL 8 COOL CTRL	DEGF
EX ZONE 8 MELT TMP	DEGF
EX ZONE 8 TEMP	DEGF
EX ZONE 8 TEMP	DEGF
EX SLIDE PLATE TEMP	DEGF
EX DIE HOUSE TEMP	DEGF
EX DIE PLATE TEMP	DEGF
EX DIE MELT TEMP	DEGF
EX PEL H2O TEMP CTL	DEGF

- 87 -

APPENDIX 2 E**The EX831 PCA Model****With Sensor Description, Engineering Units**

<u>Tag Description</u>	<u>Eng. Unit</u>
EX MAIN MOTOR POWER	KW
EX PELLETIZER KWS	KW
Ex Total Feed	LB/HR
EX N2 INJ FLOW CTL	PCT
EX N2 INJ FLOW CTL	SCFH
EX HEAD PRESSURE	PSIG
EX DIE HOUSE PRESSURE	PSIG
EX BARREL 2 COOL CTRL	DEGF
EX BARREL 3 COOL CTRL	PCT
EX BARREL 3 COOL CTRL	DEGF
EX BARREL 4 COOL CTRL	PCT
EX BARREL 4 COOL CTRL	DEGF
EX BARREL 5 COOL CTRL	DEGF
EX BARREL 6 COOL CTRL	DEGF
EX BARREL 7 COOL CTRL	PCT
EX BARREL 7 COOL CTRL	DEGF
EX BARREL 8 COOL CTRL	DEGF
EX ZONE 8 MELT TMP	DEGF
EX ZONE 8 TEMP	DEGF
EX ZONE 8 TEMP	DEGF
EX SLIDE PLATE TEMP	DEGF
EX DIE HOUSE TEMP	DEGF
EX DIE PLATE TEMP	DEGF
EX DIE MELT TEMP	DEGF
EX PEL H2O TEMP CTL	DEGF

- 88 -

APPENDIX 3

ENGINEERING MODELS / HEURISTIC MODELS

A. Valve-Flow-Models

There are a total of 20 valve models developed for the AED PP application. All the valve models have bias-updating implemented. The flow is compensated for the Delta Pressure in this manner:

Compensated Flow = FL / (DP/ StdDP)^a, where

FL= Actual Flow, DP = Upstream Pressure - Downstream Pressure, StdDP = Standard Delta Pressure, **a** are parameters. A plot is then made between the Estimated Compensated Flow and the Actual Compensated Flow to check the model consistency (X-Y plot). The following is the list of the 12 valve flow models. The order of the variables in the models below are thus: (OP, FL, UpP-DnP, StdDP, **a**, Bound).

Description	StdDp	Bound	A
Pre-Rx1 C3= Feed	140	0.35	0.43
Pre-RX1 Pump C3= SEAL FLUSH	213	0.21	0.1
C3= FLSH TO Pre-Rx1 LETDOWN	166	1.75	0.9
RX1 C3=Feed	152	24	0.19
RX1 Pump C3= SEAL FLUSH	186	0.52	0.26
RX1 C2=Feed	165	60	0.1
LOW RANGE H2 TO RX1	183	0.41	0.9
HIGH RANGE H2 TO RX1	181	2.85	0.9
RX2 C3=Feed	130	7.5	0.9
RX2 Pump C3= SEAL FLUSH	152	0.35	0.21
LOW RANGE H2 TO RX2	166	0.63	0.9
HIGH RANGE H2 TO RX2	150	3.5	0.23
Overhead Drum Vent	122	525	0.1
Overhead Drum C3= MakeUp	157	480	0.46
Additive Flow	400	1.75	0.2
C3= Flow To Pre-RX1 Heat Exchanger 1	340	2	0.9

RX3 C3=Feed	120	1	0.16
RX3C2=Feed	450	1.2	0.47
RX3 H2 Feed Low	500	0.55	0.42
RX3 H2 Feed High	480	1.8	0.17

B. Controller Monitor (CM) & Sensor Check (SC) Monitors:

The CM and SC cover the critical controllers and sensors in the Poly8 Sensor Check, and Poly4 Sensor Check Areas. The CM detects frozen instrument, highly variant instrument, or controller malfunction when any of the below violates the rule limits:

1. Standard Deviation
2. The accumulation of the length of time during which the measurement is not meeting and not criss-crossing the setpoint
3. The accumulation of the deviation between the measurement and the setpoint.

The SC checks the relationship between sensors for violation of the correlation rule limits.

The CM and SC monitors are implemented for the below critical instruments:

Instrument	Type of Monitoring
Pre RX1 Temp1 Pre RX1 Temp2	Cross-correlation between two temperatures for consistency check
RX 1 Concentration RX1 Slurry Pump Amps RX1 Slurry Pump Amps RX1 Slurry Density	Cross-correlation between reactor amps and concentration for imbalance check High standard deviation for excessive fluctuation check Low standard deviation for frozen value check
RX 2 Concentration RX2 Slurry Pump Amps RX2 Slurry Pump Amps RX2 Slurry Density	Cross-correlation between reactor amps and concentration for imbalance check High standard deviation for excessive fluctuation check Low standard deviation for frozen value check
RX3 Exchanger Fouling	Checks for violation of limits

- 90 -

Level Instrument 1	Low standard deviation for frozen value check
Level Instrument 2	Low standard deviation for frozen value check
Level Instrument 2	Controller frozen PV and Output check
Level Instrument 3	Low standard deviation for frozen value check
Level Instrument 3	Controller frozen PV and Output check
Level Instrument 4	Low standard deviation for frozen value check
Level Instrument 4	Controller frozen PV and Output check

C. Heuristic Model Monitors:

There are four heuristic model monitors focusing on the detection of catalyst plugging problems in the catalyst area (Poly8 Cat), and line plugging problems in the granule areas (801 Granule, 831 Granule, and Finishing4 Area).

The Poly8 Cat heuristic model focuses on the detection of catalyst plugging problem in the catalyst area by checking whether the following variables violate rule limits:

1. The Cat Line upstream pressure
2. The Cat Cylinder switching;
3. The Cat Line downstream pressure
4. The Co-catalyst and Catalyst flows
5. The Cat System Flush flow.
6. Pre-RX1 temperature

The 801 Granule, 831 Granule and Finishing 4 Area heuristic models focus on the detection of plugging problems in the three subjected granule areas by checking whether the following variables in each area violate the rule limits:

1. Weight Feeder speeds
2. Feed flow
3. Blender Speed
4. Weight Feeder motors
5. Pressure fluctuates

- 91 -

CLAIMS:

1. A method for abnormal event detection (AED) for Polymers Process comprising:
 - (a) comparing online measurements from the process units to a set of models for normal operation of the corresponding process units,
 - (b) determining if the current operation differs from expected normal operations so as to indicate the presence of an abnormal condition in a process unit,
 - (c) assisting the process operator to determine the underlying cause of an abnormal condition in the Polymers Process, and
 - (d) performing corrective action to return the unit to normal operation.
2. The method of claim 1 wherein said set of models correspond to equipment groups and operating modes, one model for each group which may include one or more operating mode.
3. The method of claim 1 wherein said set of models correspond to equipment groups and process operating modes, one model for each group and each mode.
4. The method of claim 2 wherein said equipment groups include all major material and energy interactions in the same group.
5. The method of claim 4 wherein said equipment groups include quick recycles in the same group.
6. The method of claim 5 wherein said set of models of normal operations include principle component models.

- 92 -

7. The method of claim 6 wherein set of models of normal operations includes engineering models.

8. The method of claim 1 wherein said set of models of normal operation for each process unit is either a Principle Components model, or an engineering model, or an heuristic model.

9. The method of claim 1 wherein said model of normal operation for each process unit is determined using principle components analysis (PCA), correlation-based engineering models, or heuristic models.

10. The method of claim 9 wherein said Polymers Process areas are decomposed into eleven abnormality monitors.

11. The method of claim 1 wherein said process units are divided into operational sections of the Polymer Process system.

12. The method of claim 11 wherein there are nine operational sections.

13. The method of claim 11 wherein the nine operational sections comprises of nine operation sections - the catalyst preparation area (Cat Prep), reactors (RX), recycle gas compressors, recycle gas recovery system, the dryers, two granule areas and two extruders system.

14. The method of claim 9 wherein each of the abnormality monitors generates a continuous signal indicating the probability of an abnormal condition in the area.

15. The method of claim 9 wherein said models include process variables values measured by sensors.

16. The method of claim 9 wherein said principle components of models for different process units include some process variable values measured by the same sensor.

- 93 -

17. The method of claim 13 wherein said model further identifies the consistency or relationship between tags around a specific unit, catalyst, reactors, dryers, recycle area, and valves/flows, to indicate any early breakdown in the relationship pattern.

18. The method of claim 17 wherein said model further comprises suppressing model calculations to eliminate false positives on special cause operations.

19. The method of claim 9 wherein (a) determining said model begins with a rough model based on questionable data, (b) using said rough model to gather high quality training data, and improve the model, and (c) repeating step (b) to further improve the model.

20. The method of claim 19 wherein said training data includes historical data for the model of the processing unit.

21. The method of claim 20 wherein said model includes transformed variables.

22. The method of claim 21 wherein said transformed variables include reflux to feed ratio in distillation columns, log of composition in high purity distillation, pressure compensated temperature measurement, sidestream yield, flow to valve position, and reaction rate to exp (temperature).

23. The model of claim 19 wherein some pairs of measurements for two variables are brought into time synchronization by one of the variables using a dynamic transfer function.

24. The model of claim 20 wherein variables of process measurements that are affected by operating point changes in process operations are converted to deviation variables by subtracting the moving average.

- 94 -

25. The method of claim 20 wherein said model is corrected for noise.

26. The method of claim 25 wherein said model is corrected by filtering or eliminating noisy measurements of variables.

27. The method of claim 20 wherein the measurements of a variable are scaled.

28. The method of claim 27 wherein the measurements are scaled to the expected normal range of that variable.

29. The method of claim 4 where a list of abnormality monitors automatically identified, isolated, ranked and displayed for the operator.

30. The method of claim 9 where the operator is presented with diagnostic information at different levels of detail to aid in the investigation of the event.

31. The method of claim 20 wherein the number of principle components is chosen such that coefficients of the principle component become about equal in size.

32. The method of claim 4 wherein said Principle Components include process variables provided by online measurements.

33. The model of claim 32 wherein some measurement pairs are time synchronized to one of the variables using a dynamic filter.

34. The model of claim 32 wherein the process measurement variables affected by operating point changes in the process operations are converted to deviation variables.

- 95 -

35. The method of claim 32 wherein the number of principle components is selected by the magnitude of total process variation represented by successive components.

36. A system for abnormal event detection (AED) for some of the Polymers Process units comprised of:

- (a) a set of models for the process units describing operations of the process units,
- (b) a display which indicates if the current operation differs from expected normal operations so as to indicate the presence of an abnormal condition in the process unit,
- (c) a display which indicates the underlying cause of an abnormal condition in the Polymers process unit.

37. The system of claim 36 wherein said model for each process unit is either a Principle Components model or an engineering model or a heuristic model.

38. The system of claim 37 wherein a PP is partitioned into three operational sections with a Principle Components model for each section.

39. The system of claim 38 wherein said Principle Components include process variables provided by online measurements.

40. The system of claim 38 wherein said model further comprises suppressing model calculates to eliminate operator induced notifications and false positives.

41. The system of claim 37 wherein: (a) deriving said model begins with obtaining an initial model based upon questionable data, (b) use of said initial model to refine the data and improve the model, and (c) iteratively repeating step (b) to improve the model.

- 96 -

42. The system of claim 41 wherein said training data set includes historical data of the processing unit for model development.

43. The system of claim 42 wherein said model includes transformed variables.

44. The system of claim 43 wherein said transformed variables include reflux to total product flow in distillation columns, log of composition and overhead pressure in distillation columns, pressure compensated temperature measurements, flow to valve position and bed differential temperature and pressure.

45. The system of claim 42 wherein some measurement pairs are time synchronized to one of the variables using a dynamic filter.

46. The system of claim 42 wherein the process measurement variables affected by operating point changes in the process operations are converted to deviation variables.

47. The system of claim 42 wherein the measurements of a variable are scaled prior to model identification.

48. The system of claim 47 wherein the measurements are scaled by the expected normal range of that variable.

49. The system of claim 42 wherein the number of principle components is selected by the magnitude of total process variation represented by successive components.

50. The method of claim 1 wherein said polymer process is a polyolefin process.

51. The method of claim 50 wherein said polyolefin process is a polyethylene or polypropylene process or a combination thereof.

- 97 -

52. The system of claim 36 wherein said polymer process is a polyolefin process.

53. The system of claim 52 wherein said polyolefin process is a polyethylene or polypropylene process or a combination thereof.

54. The system of claim 36 wherein said set of models include the automatic detection of grade switches, grade transitional duration and the automatic suppression of models during transitional duration.

55. The system of claim 36 wherein said system includes the automatic switching of on-line models.

56. The system of claim 36 wherein said set of models include different models for different family of grades.

Abnormal Event Detection On-Line Information Flow

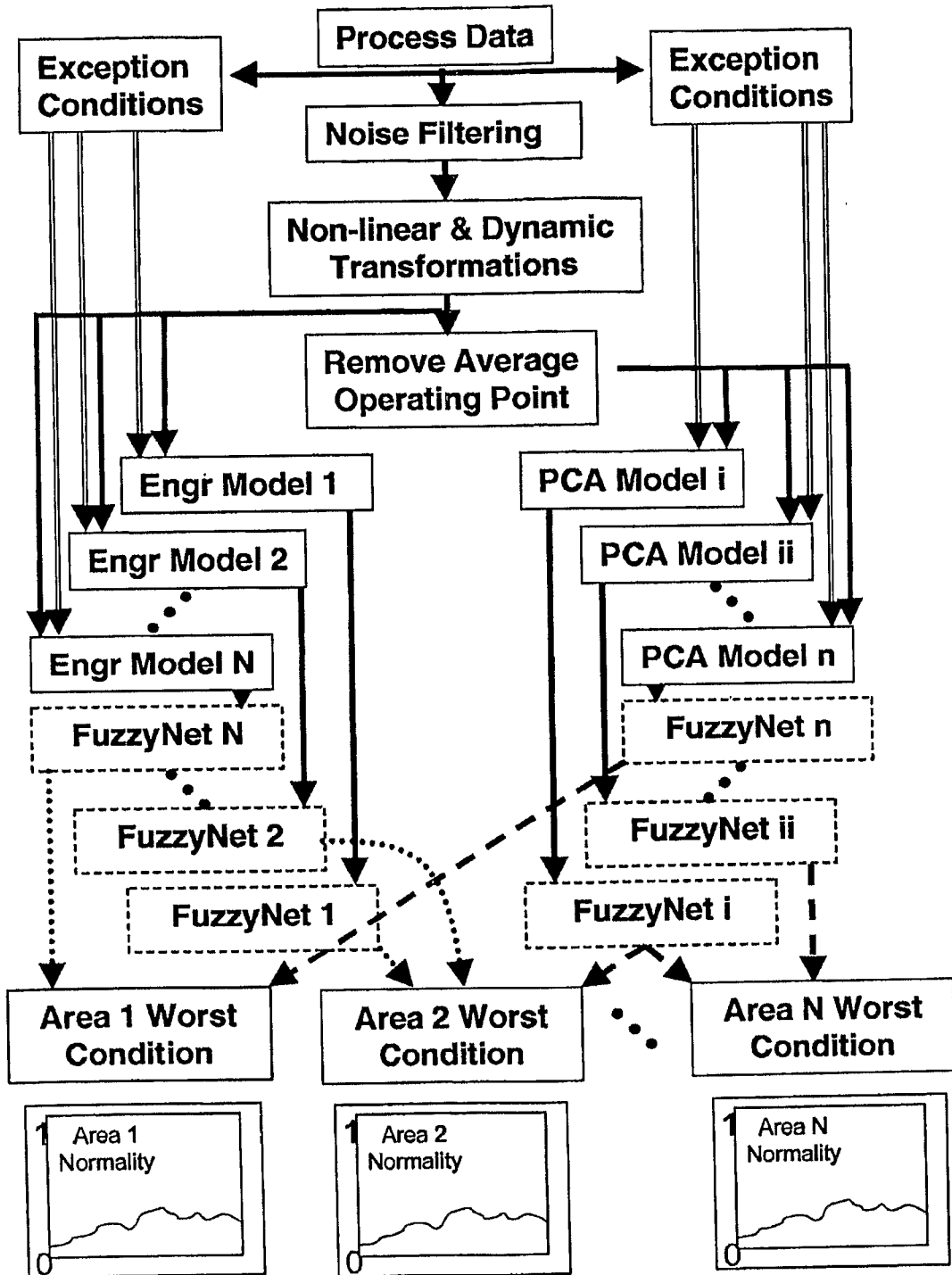

FIG. 1

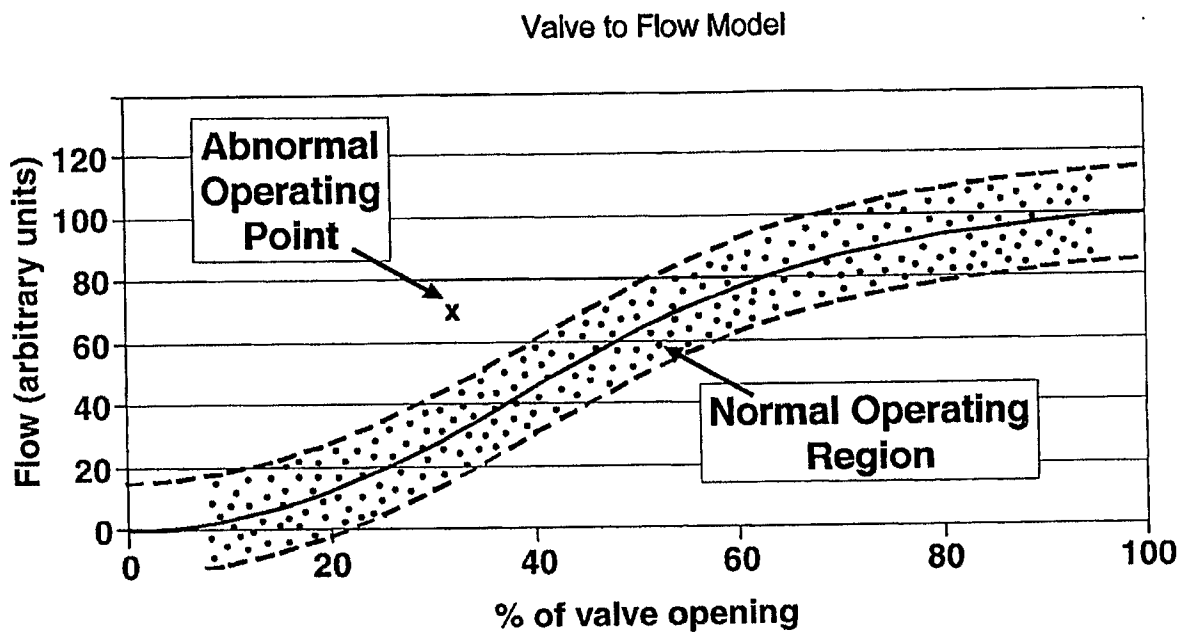

FIG. 2

Three Dimensional Redundancy Expressed as a PCA Model

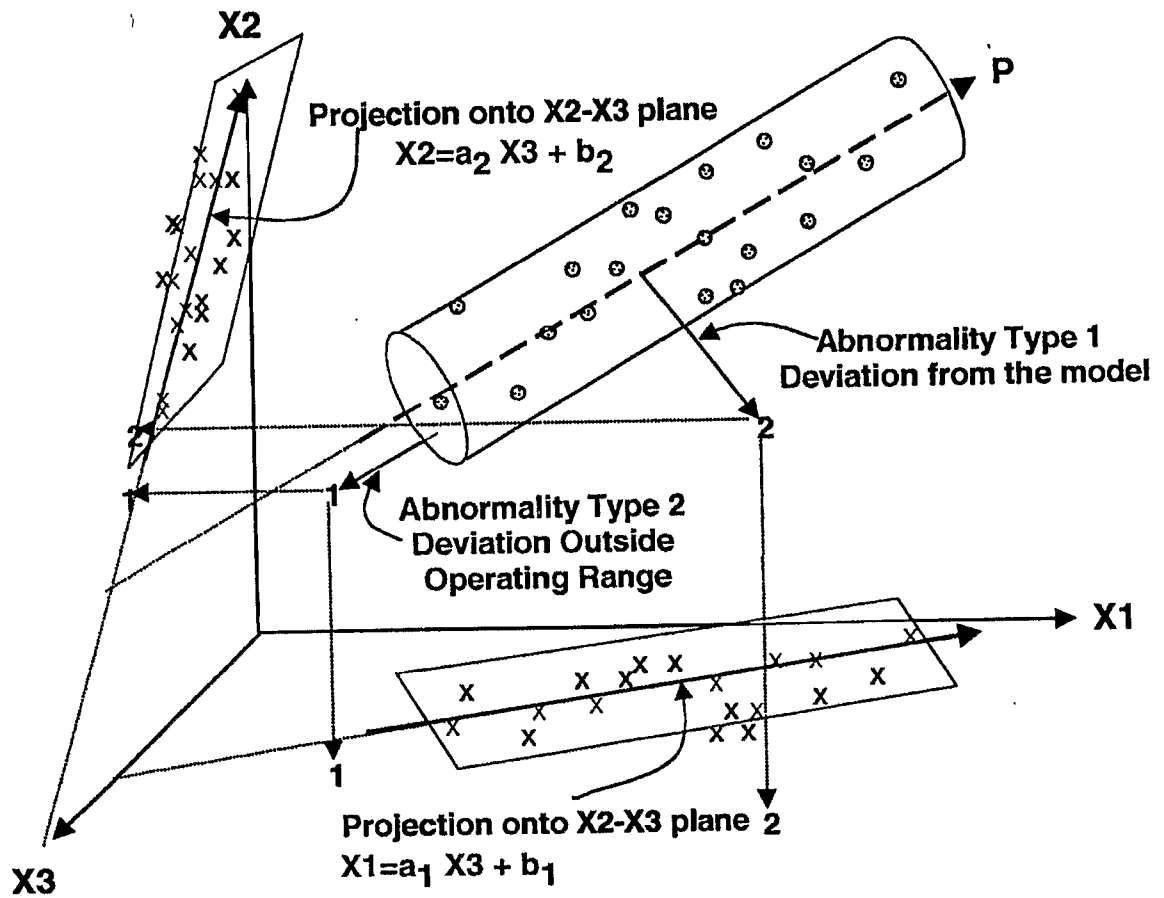

FIG. 3

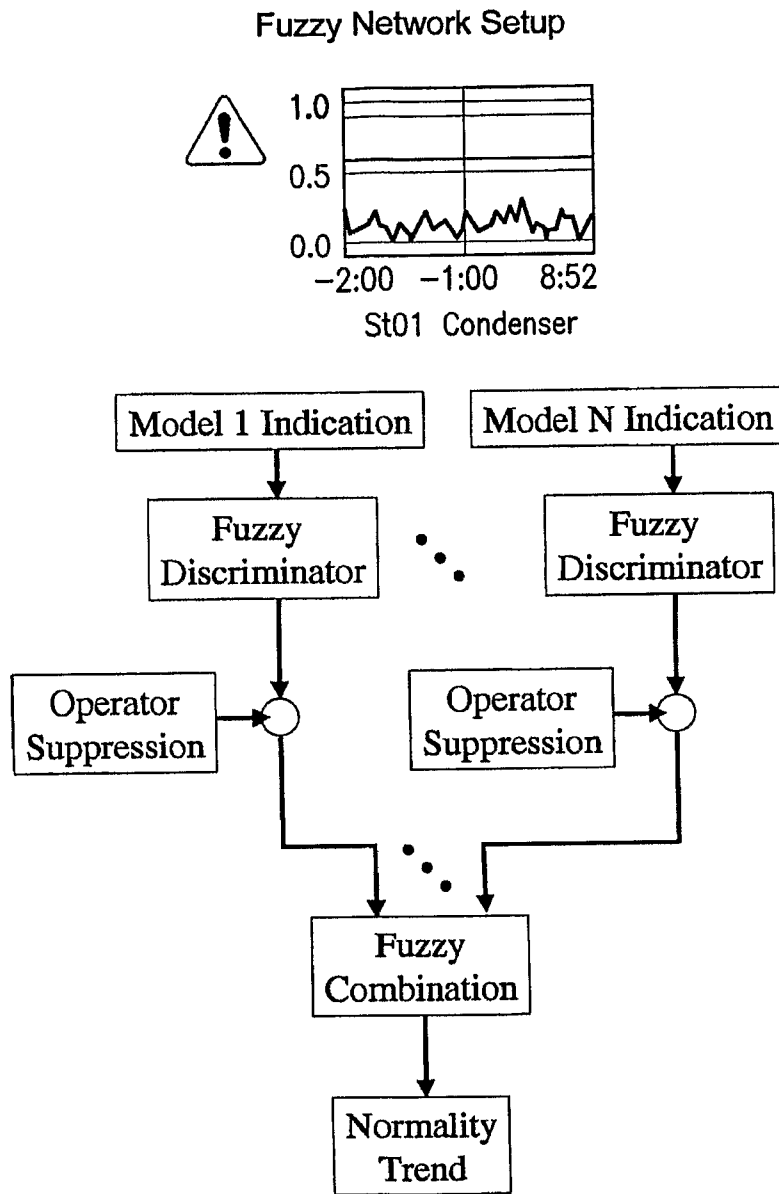

FIG. 4

Process For Developing a PCA Abnormal Event Detector

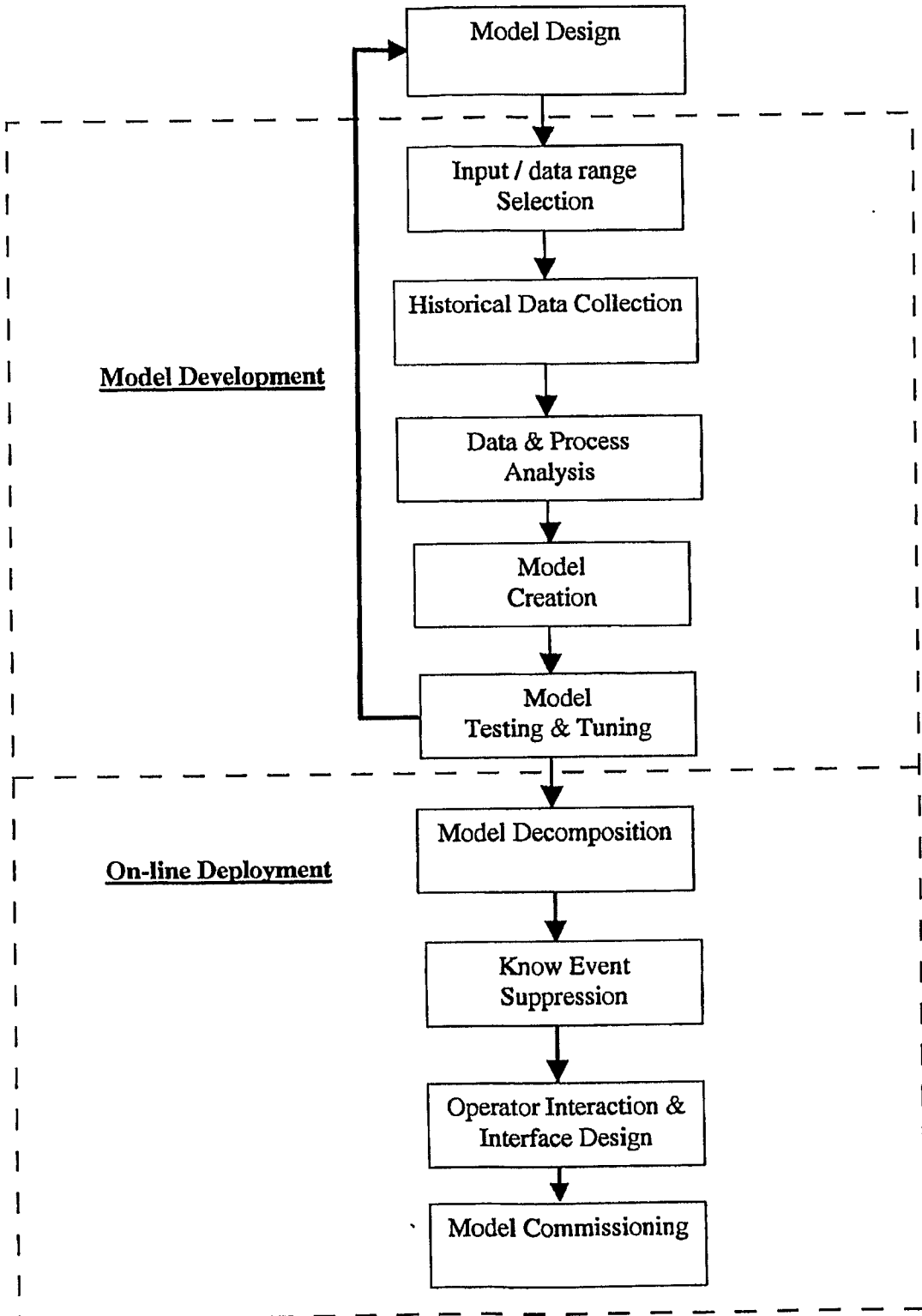

FIG. 5

Anatomy of a Process Control Cascade

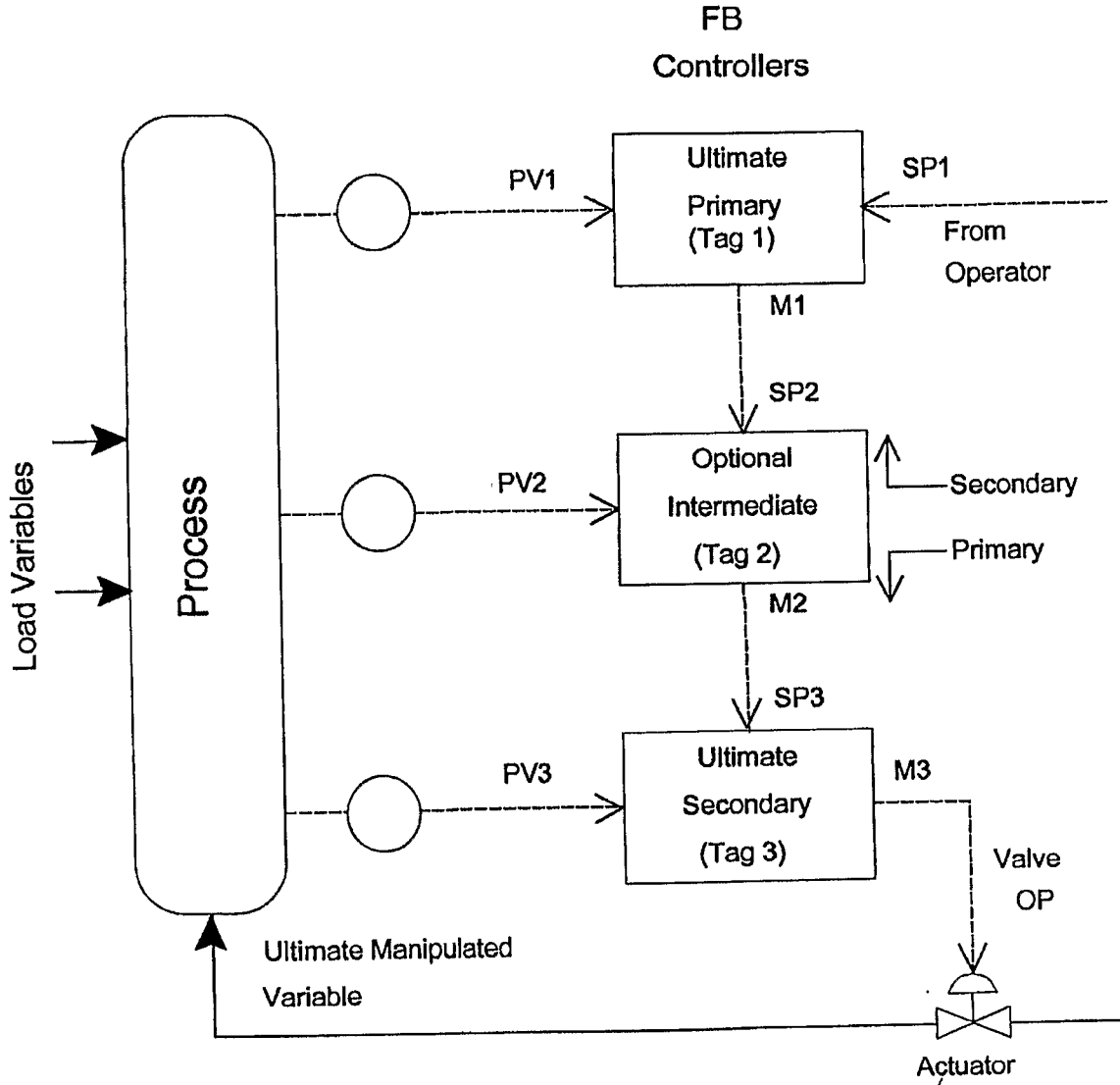

FIG. 6

Anatomy of a Multivariable Constraint Controller, MVCC

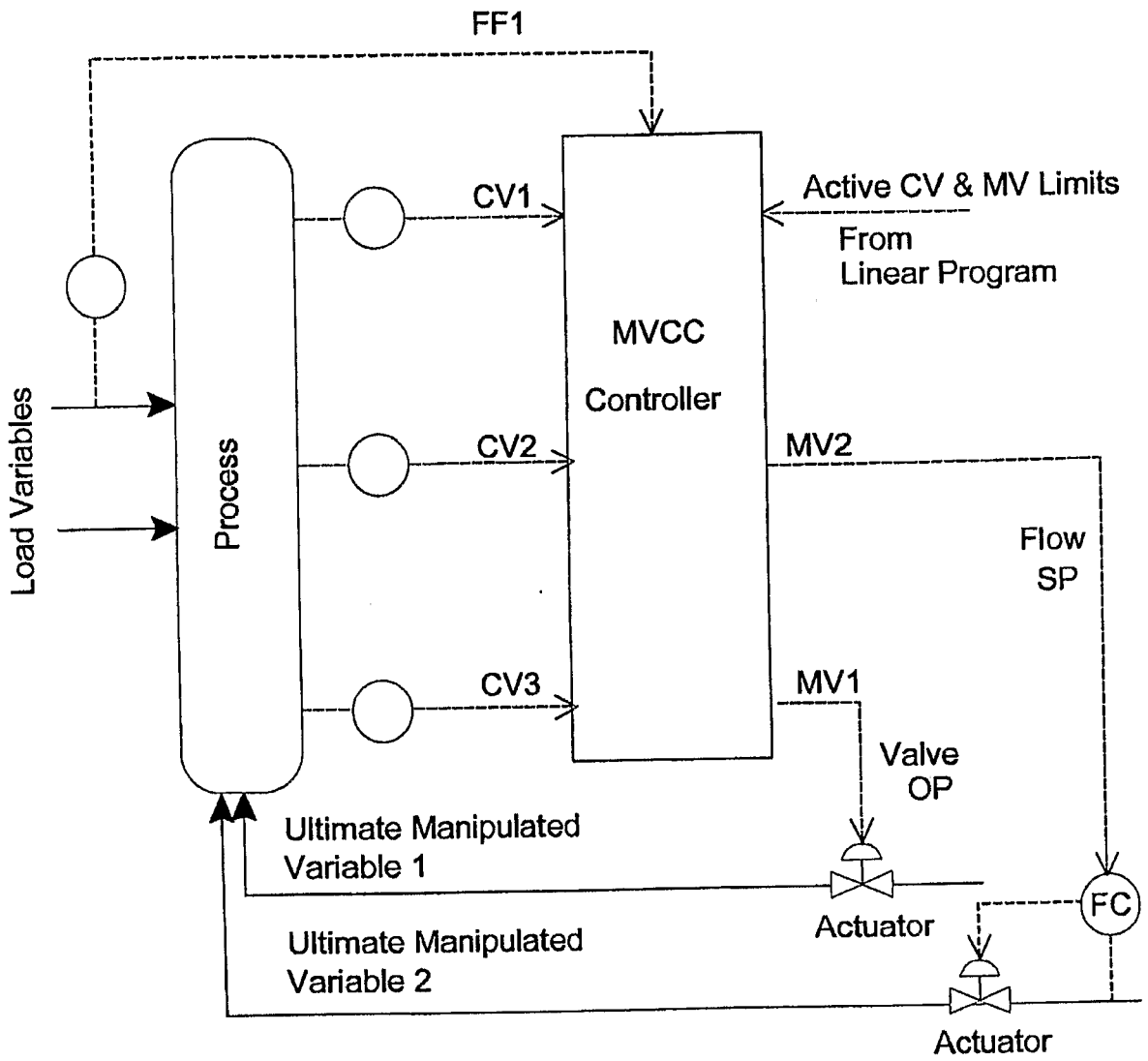

FIG. 7

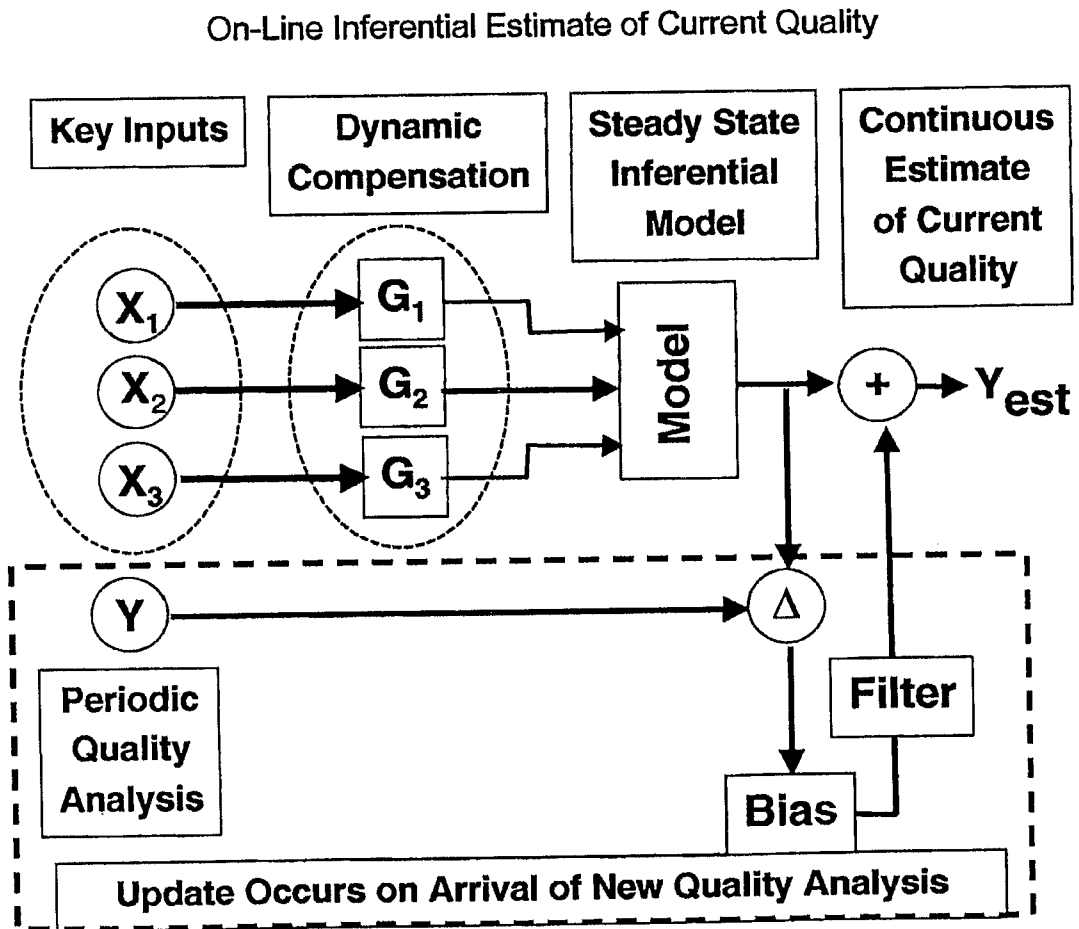

FIG. 8

KPI Analysis of Historical Data

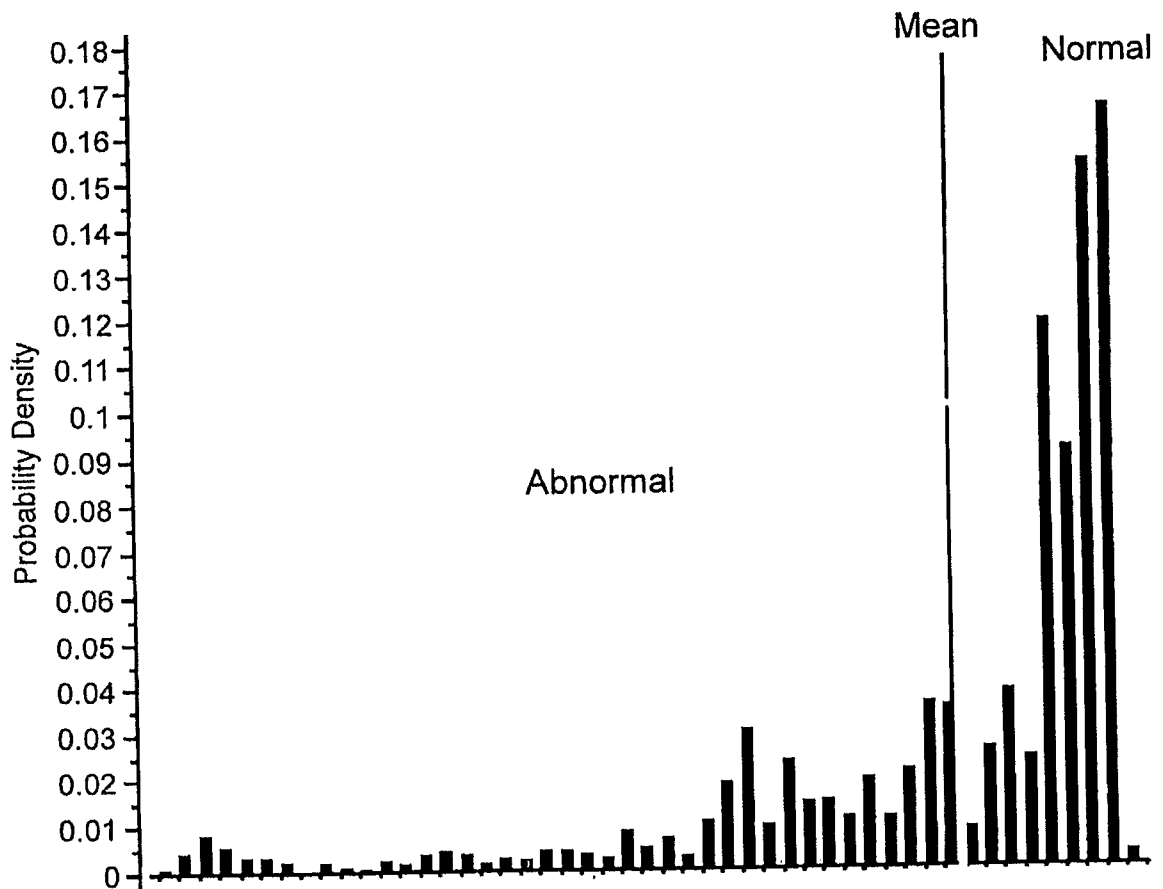

FIG. 9

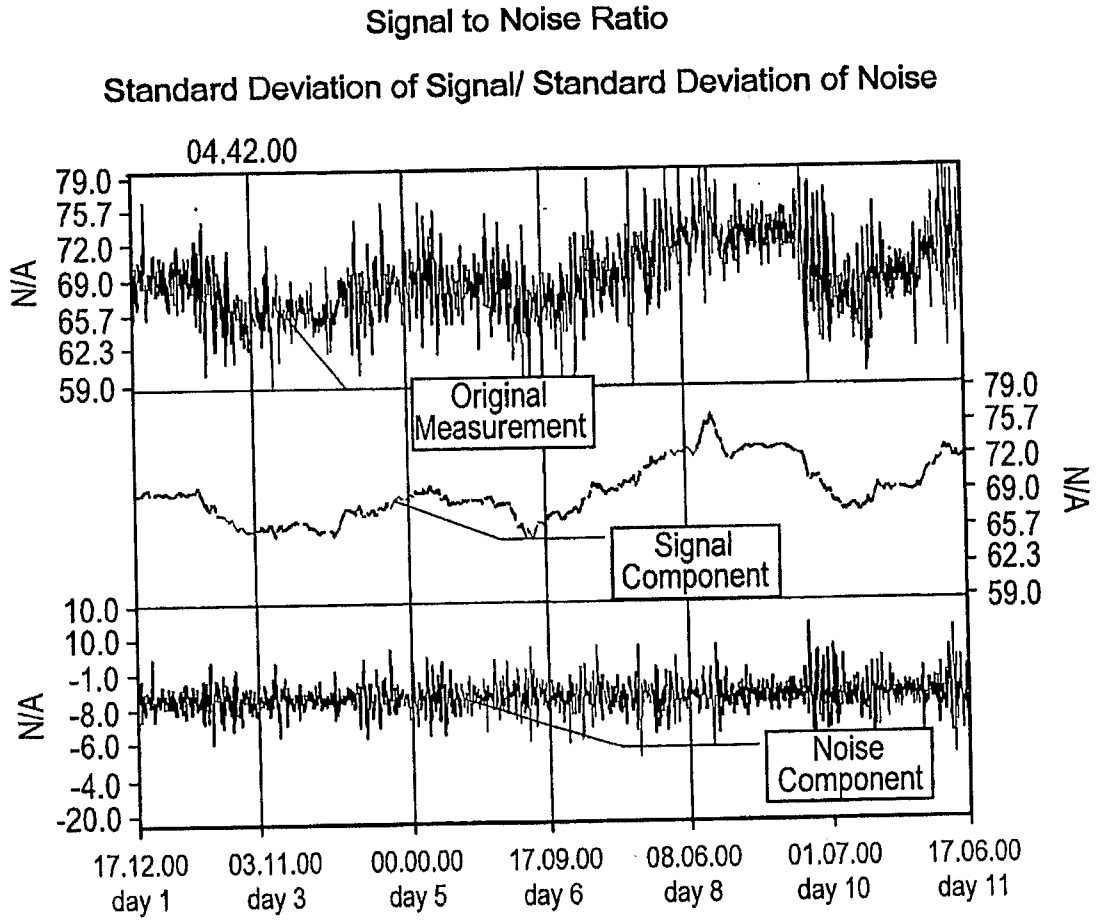

FIG. 10

Example of the Need for Dynamic Reconciliation

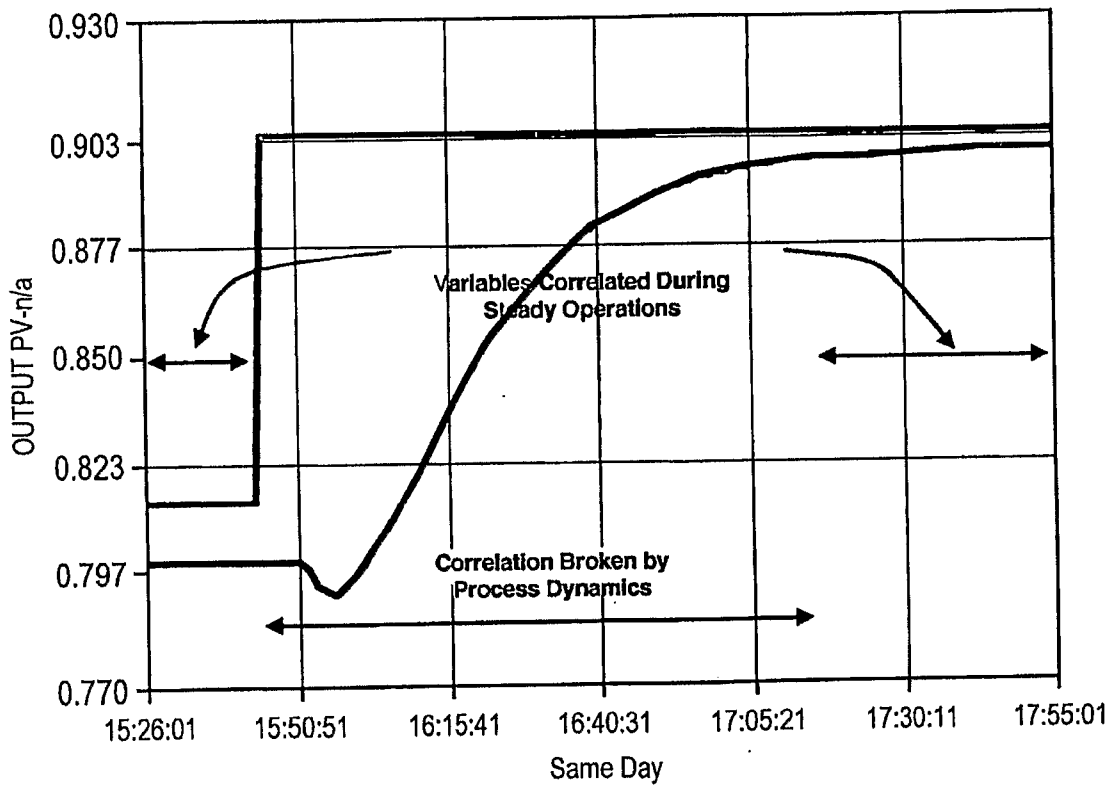
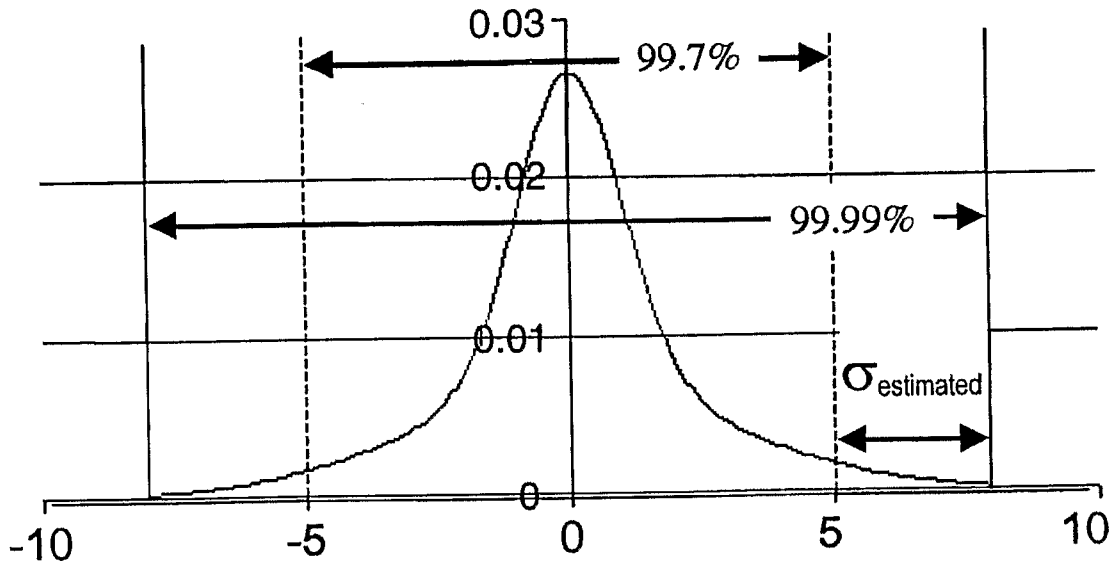
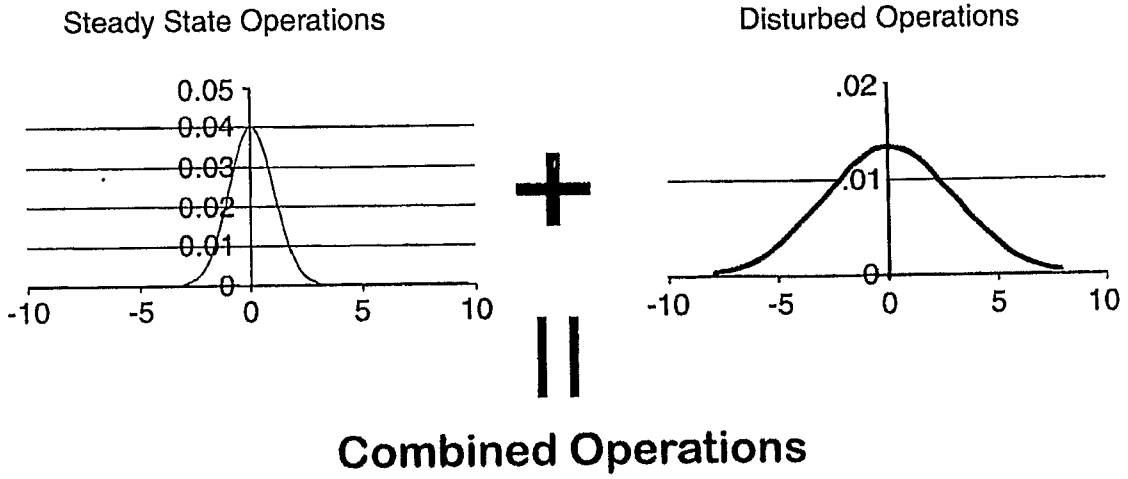

FIG. 11



Probability Distribution of Process Data
Combined Continuous and Disturbed Operations

FIG. 12

An Illustration of the Press Statistic

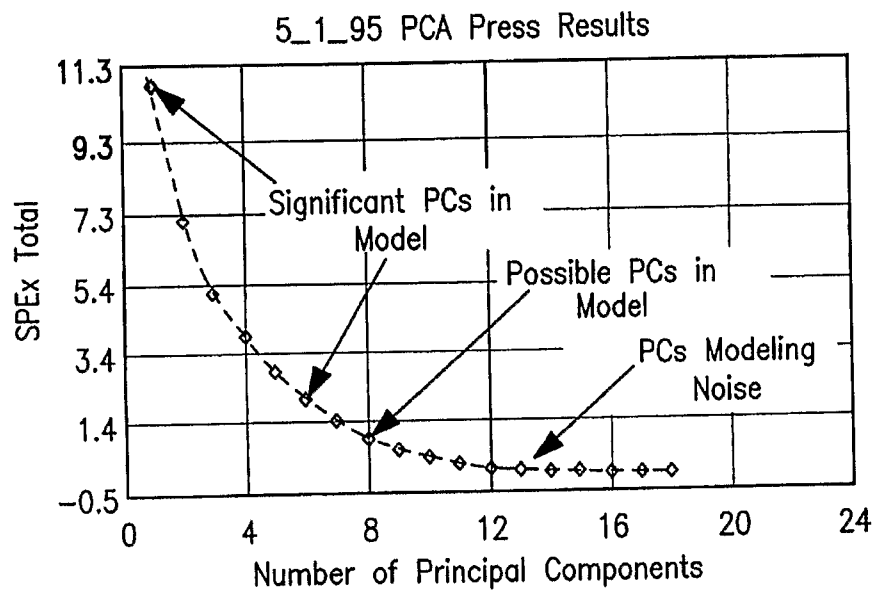

FIG. 13

Two Dimensional Energy Balance Model

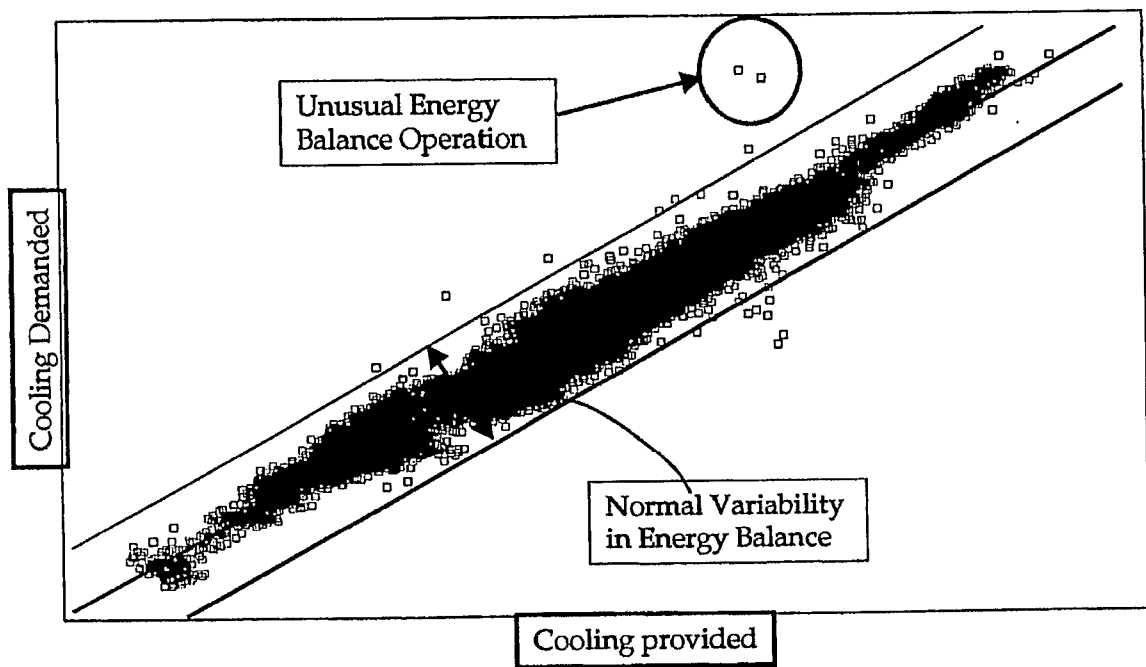

FIG. 14

Valve to Flow Data

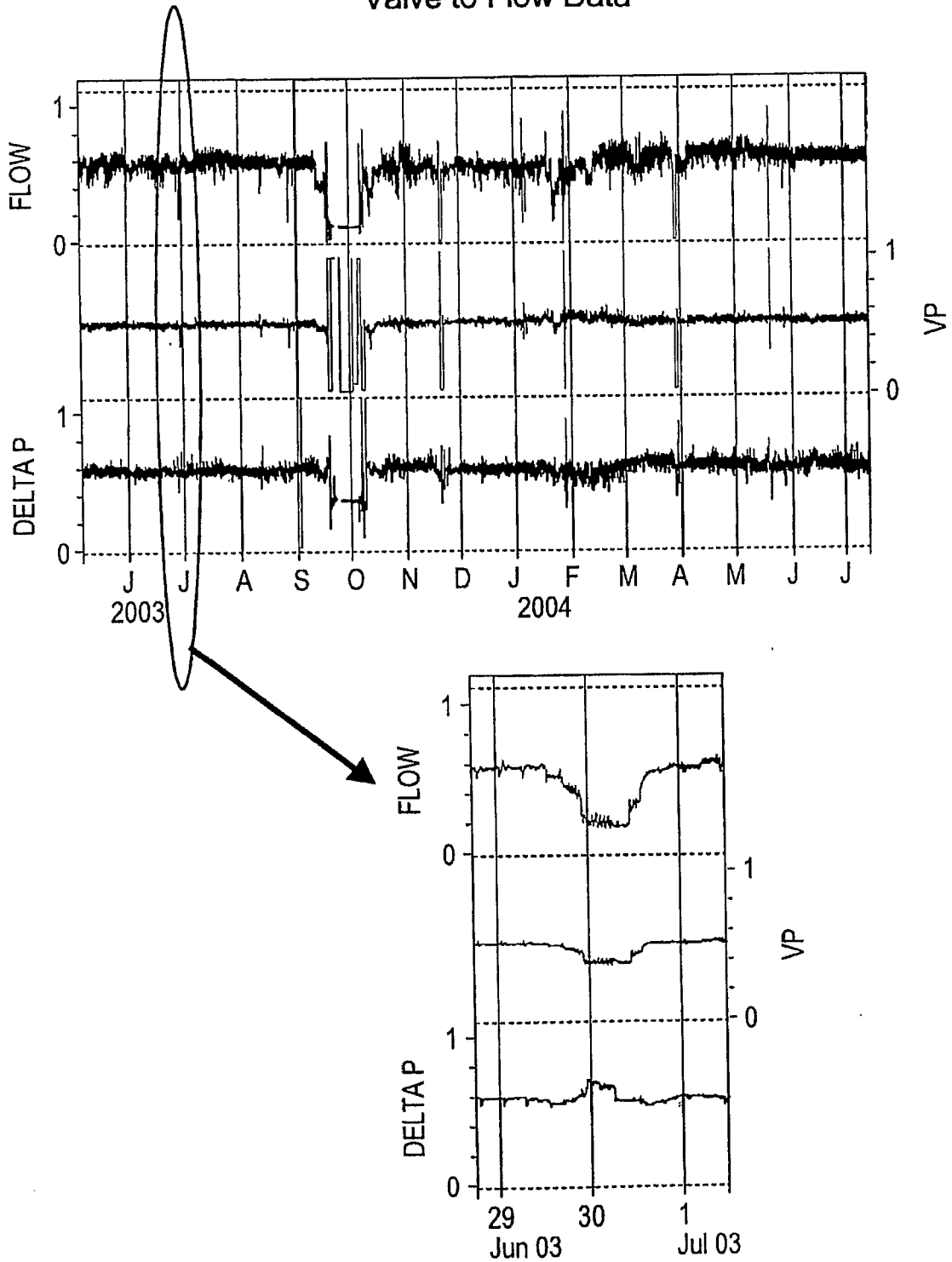

FIG. 15

Fuzzy Discriminators

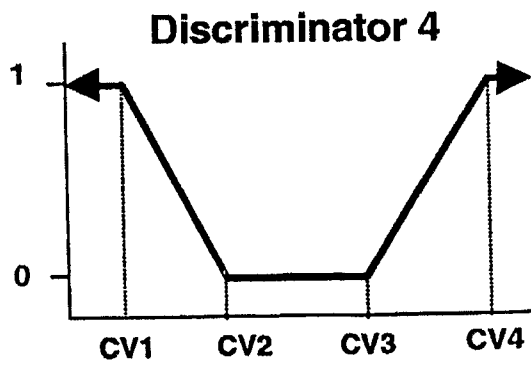
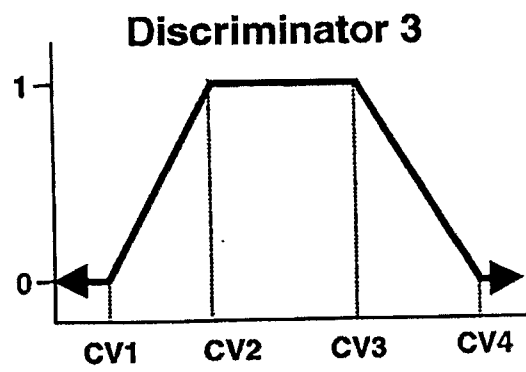
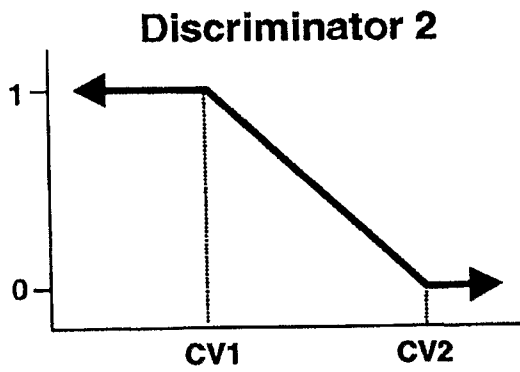
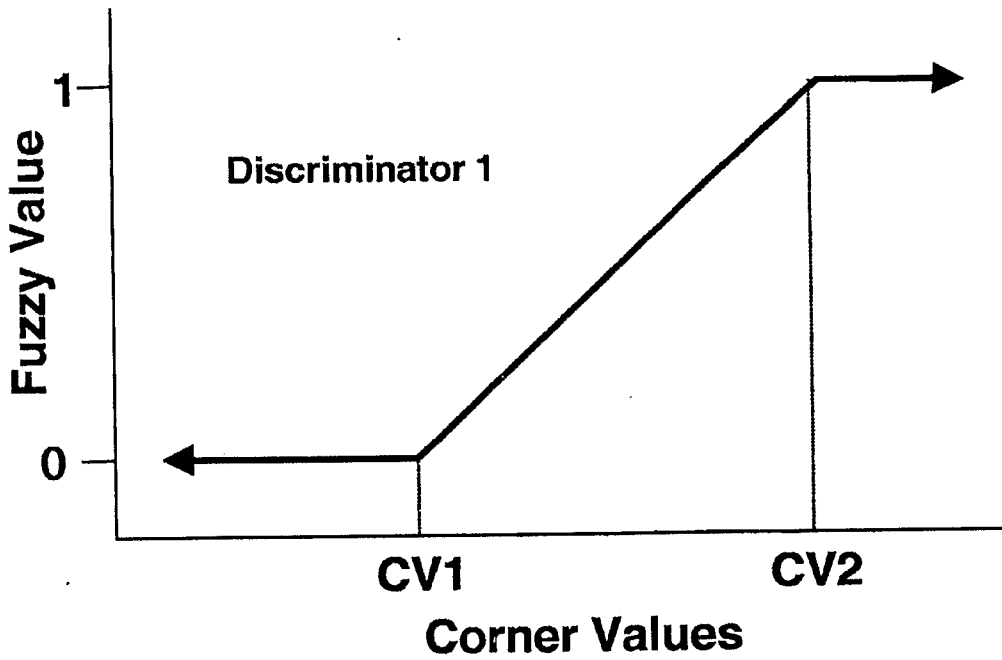

FIG. 16

Flow versus Valve Pareto Chart

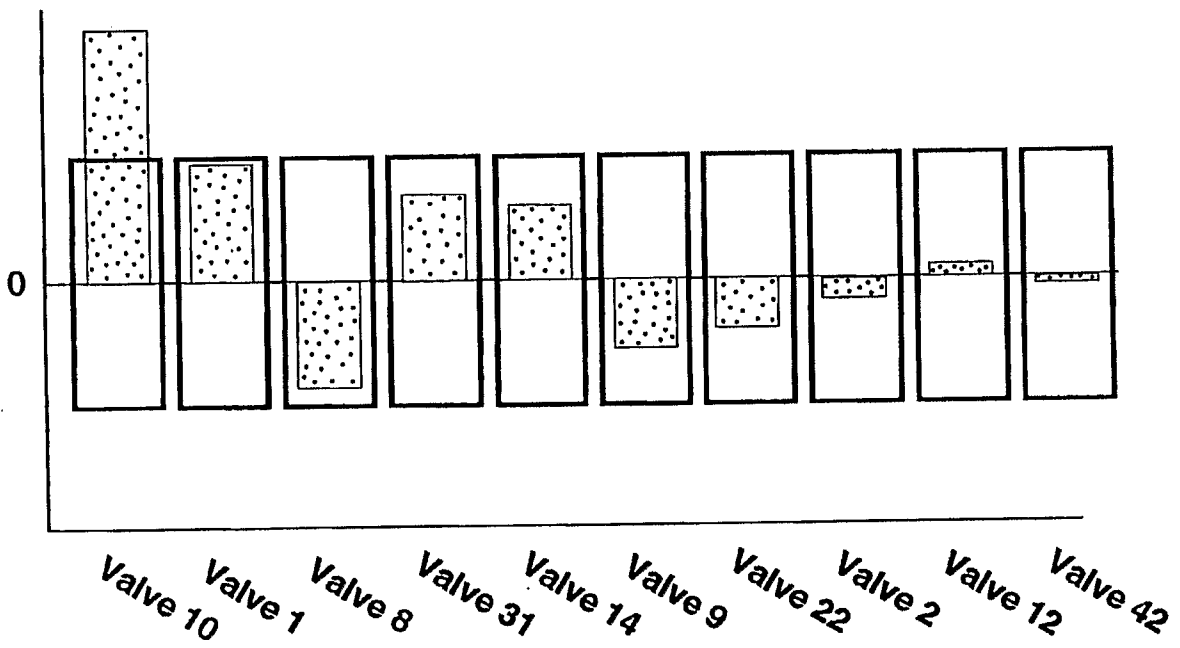

FIG. 17

Operator Suppression Logic

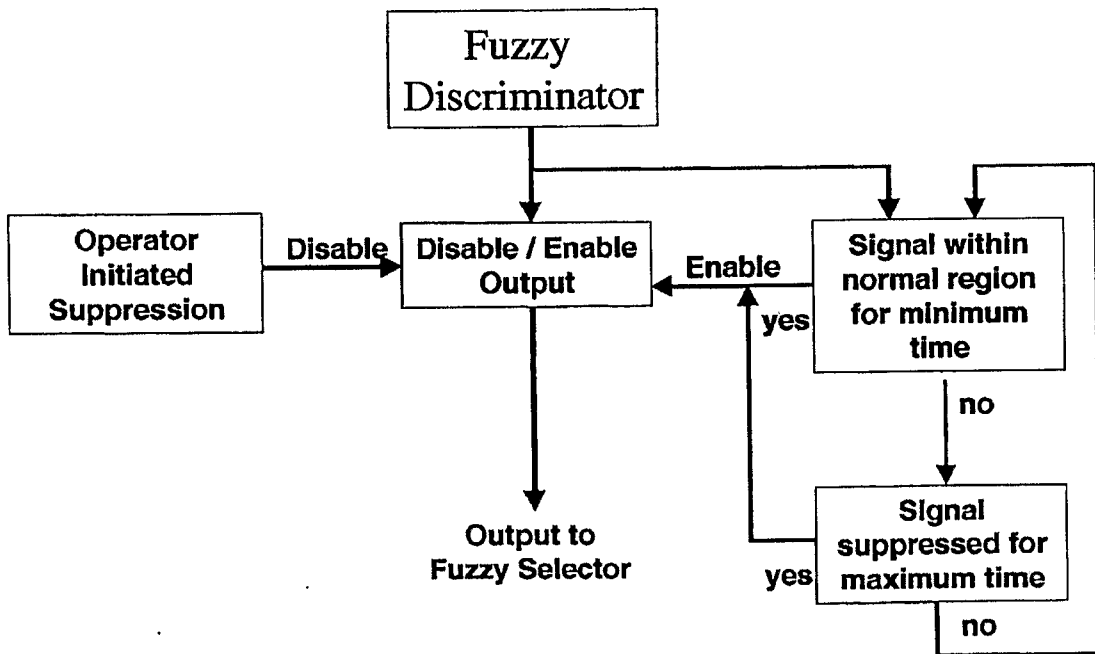

FIG. 18

Event Suppression Logic

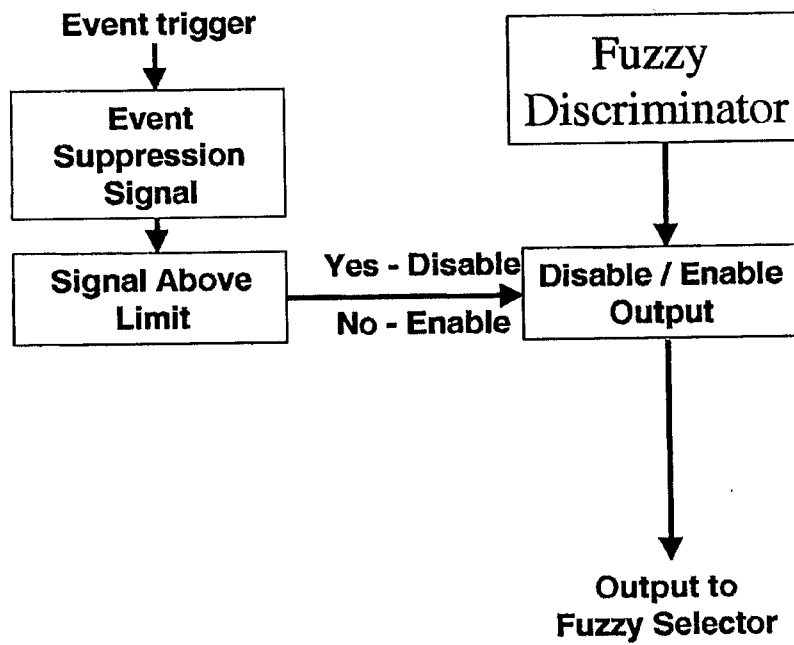

FIG. 19

Setting the Duration of Event Suppression

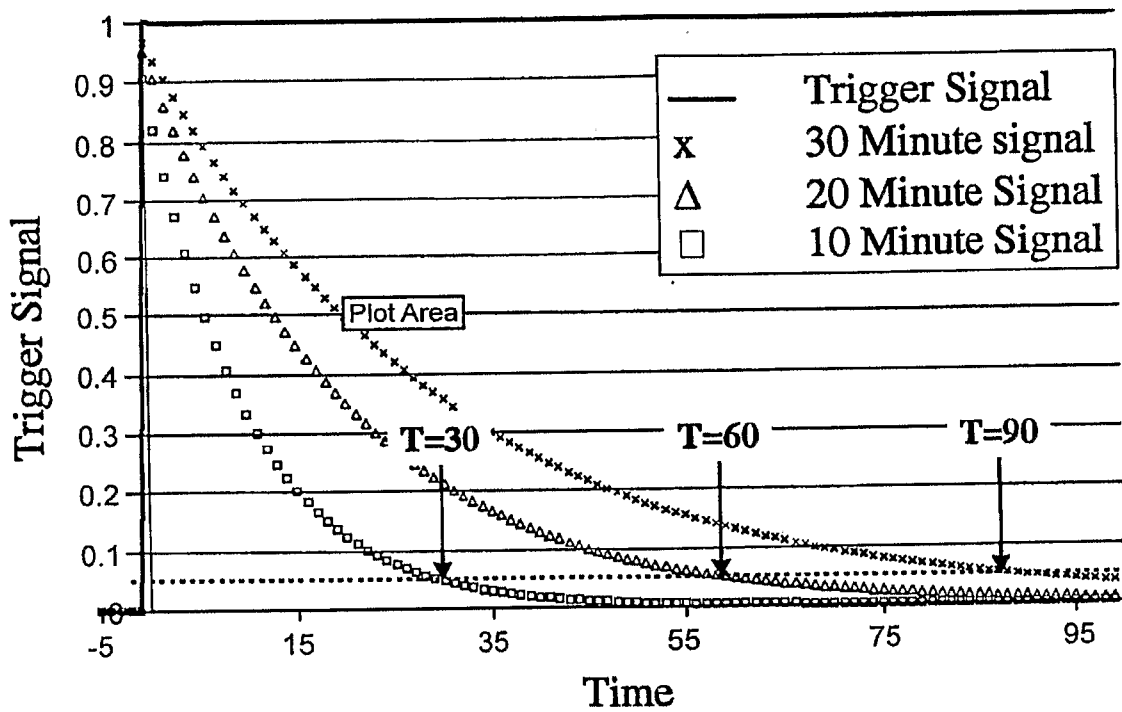

FIG. 20

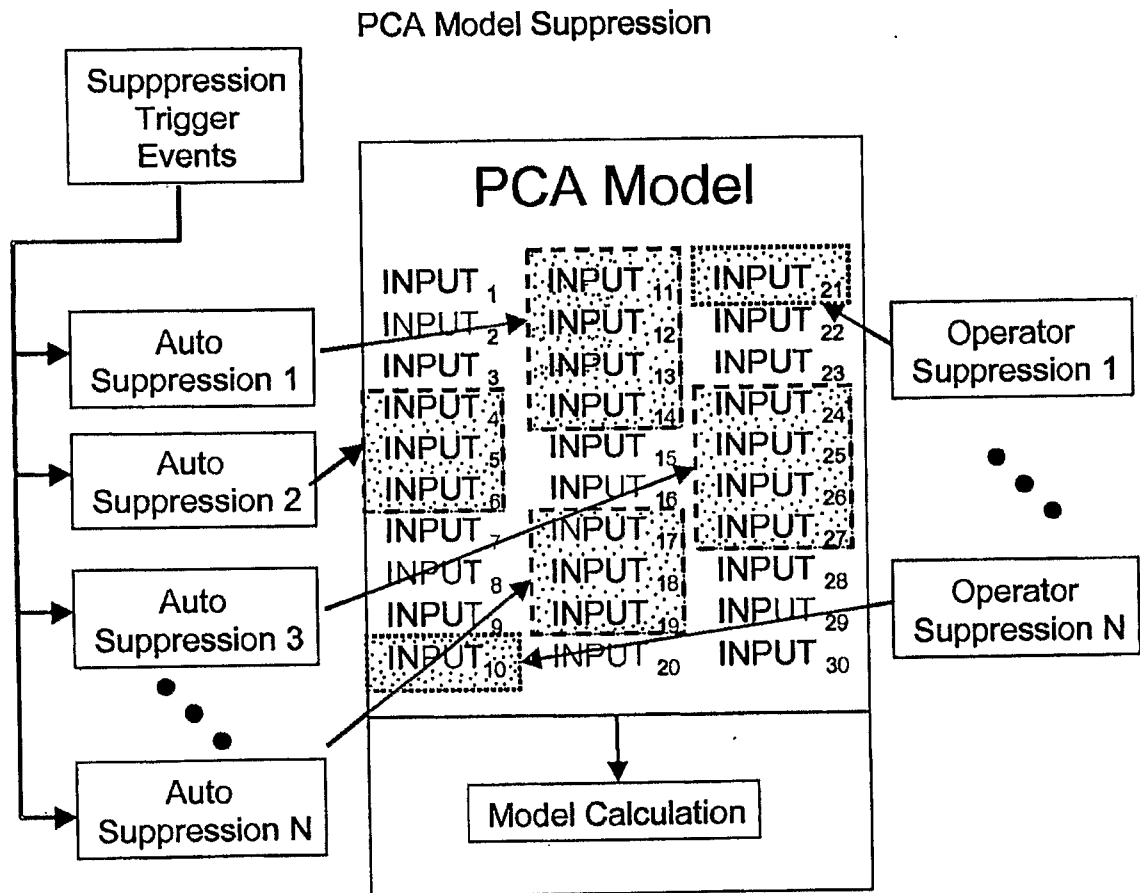

FIG. 21

Primary Operator Interface Design

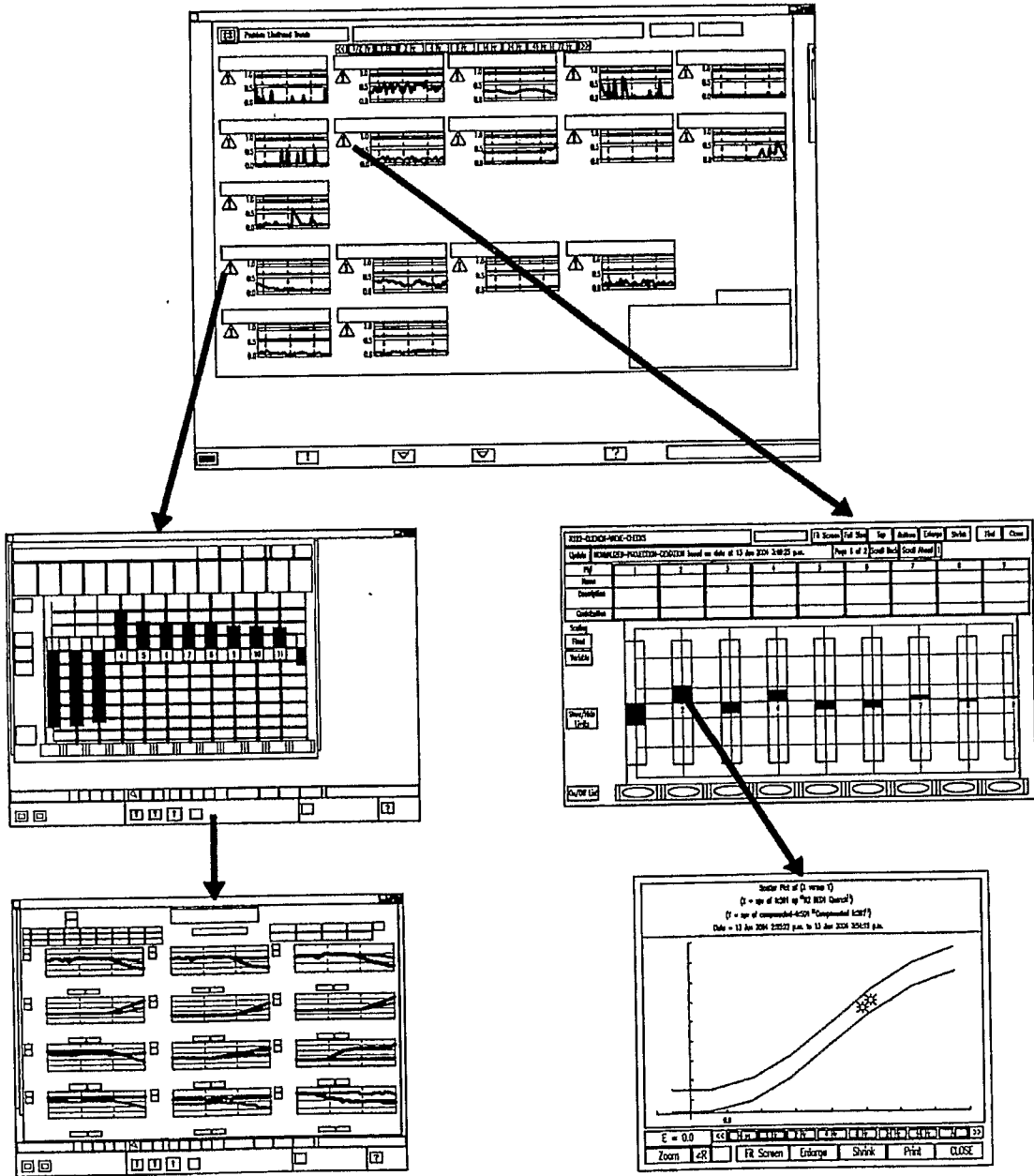

FIG. 22

PP Schematic Layout

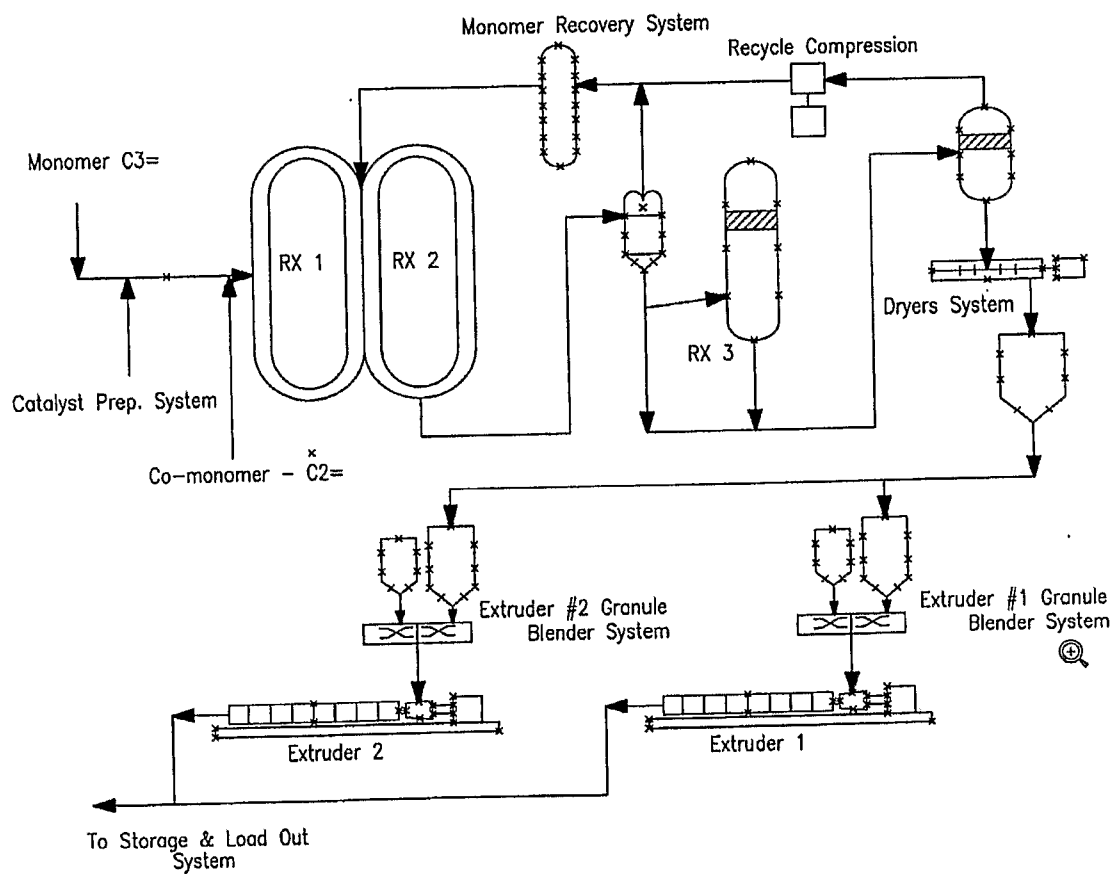

FIG. 23

AED OVERVIEW OF PP PROCESS

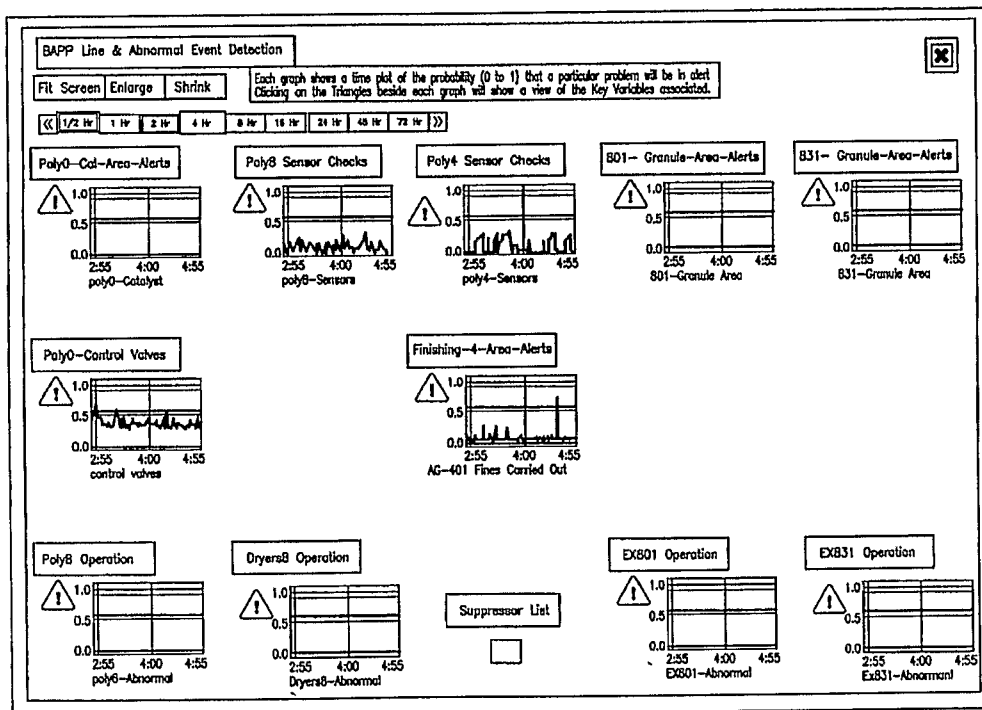

FIG. 24

FUZZY LOGIC BASED CONTINUOUS ABNORMALITY INDICATORS

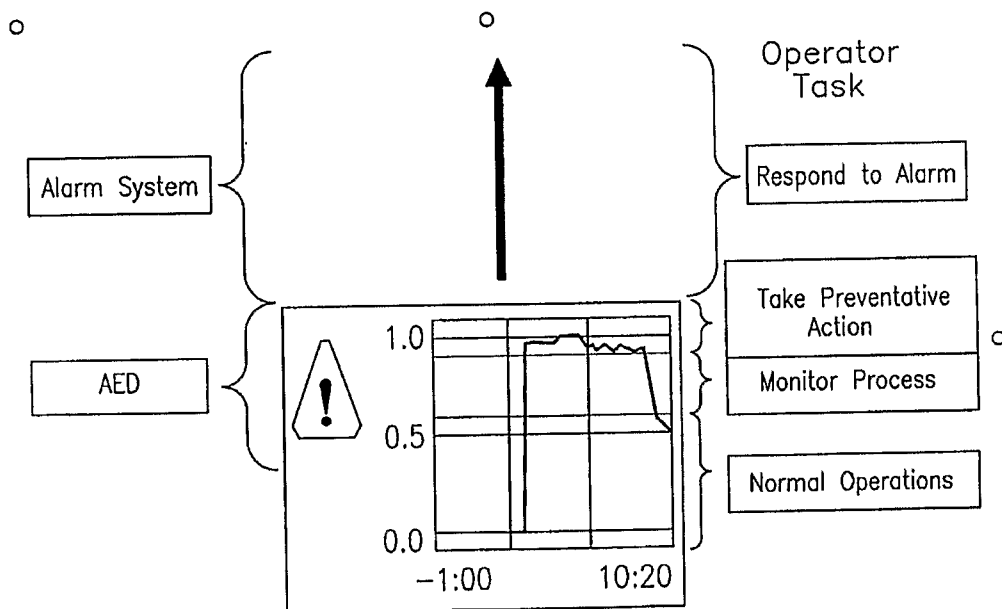

FIG. 25

PP AED DETECTS CATALYST PLUGGING PROBLEM IN THE POLY8 OPERATION AND POLY8 CAT AREAS AREA ABNORMALITY MONITORS

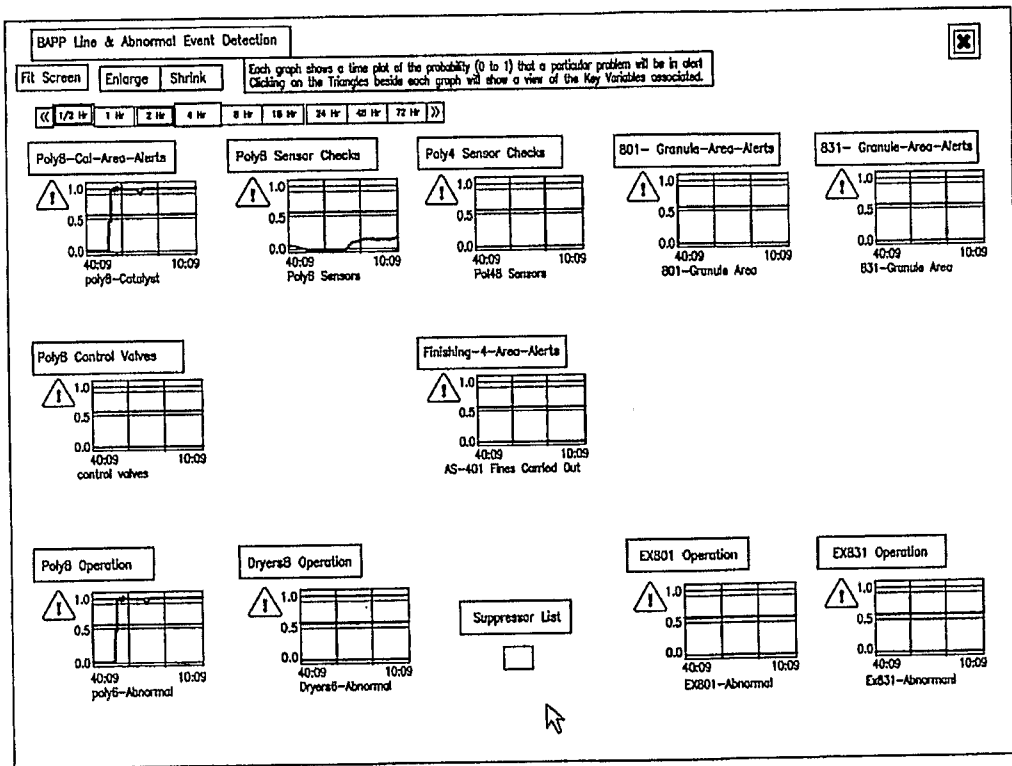

FIG. 26

COMPLETE DRILL DOWN OF THE CATALYST PLUGGING PROBLEM IN POLY8 OPERATION AREA

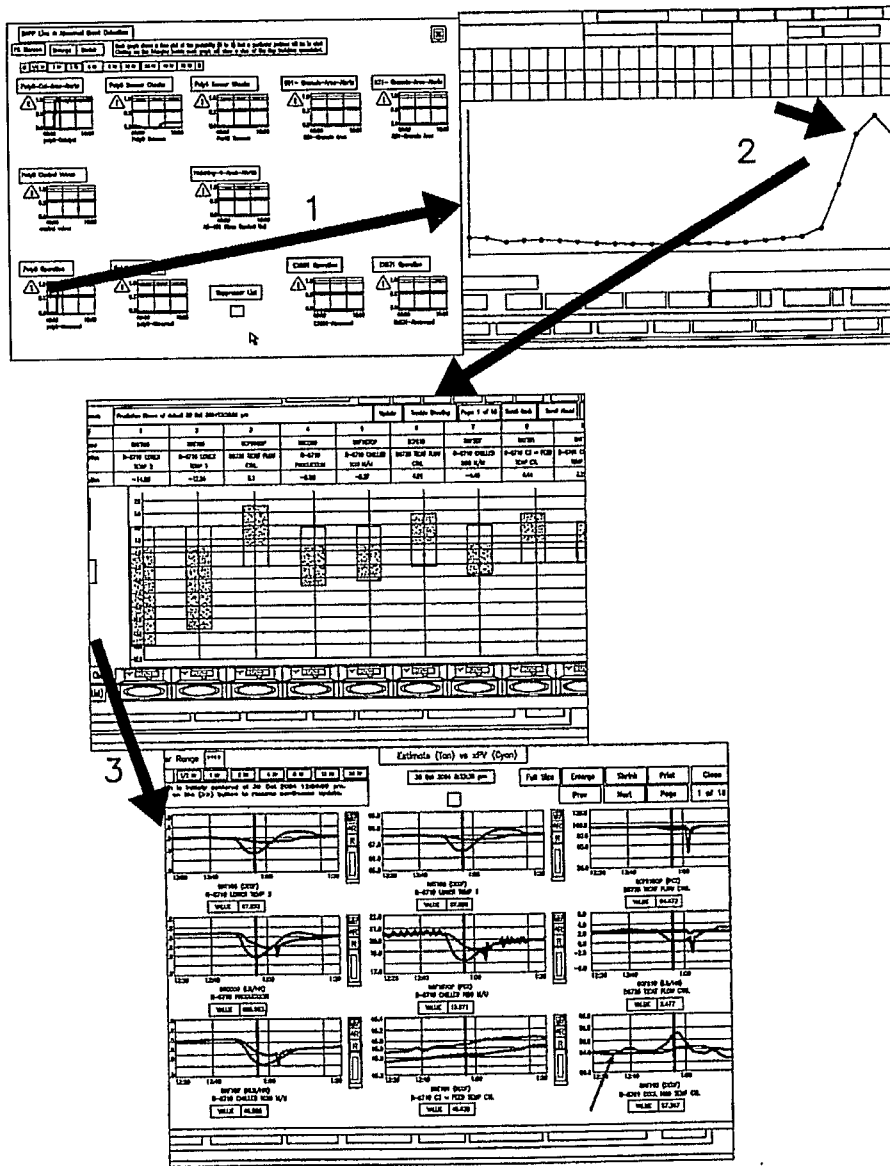

FIG. 27

Catalyst Plugging Problem Also Seen in Poly8Cat Area Abnormality Monitor

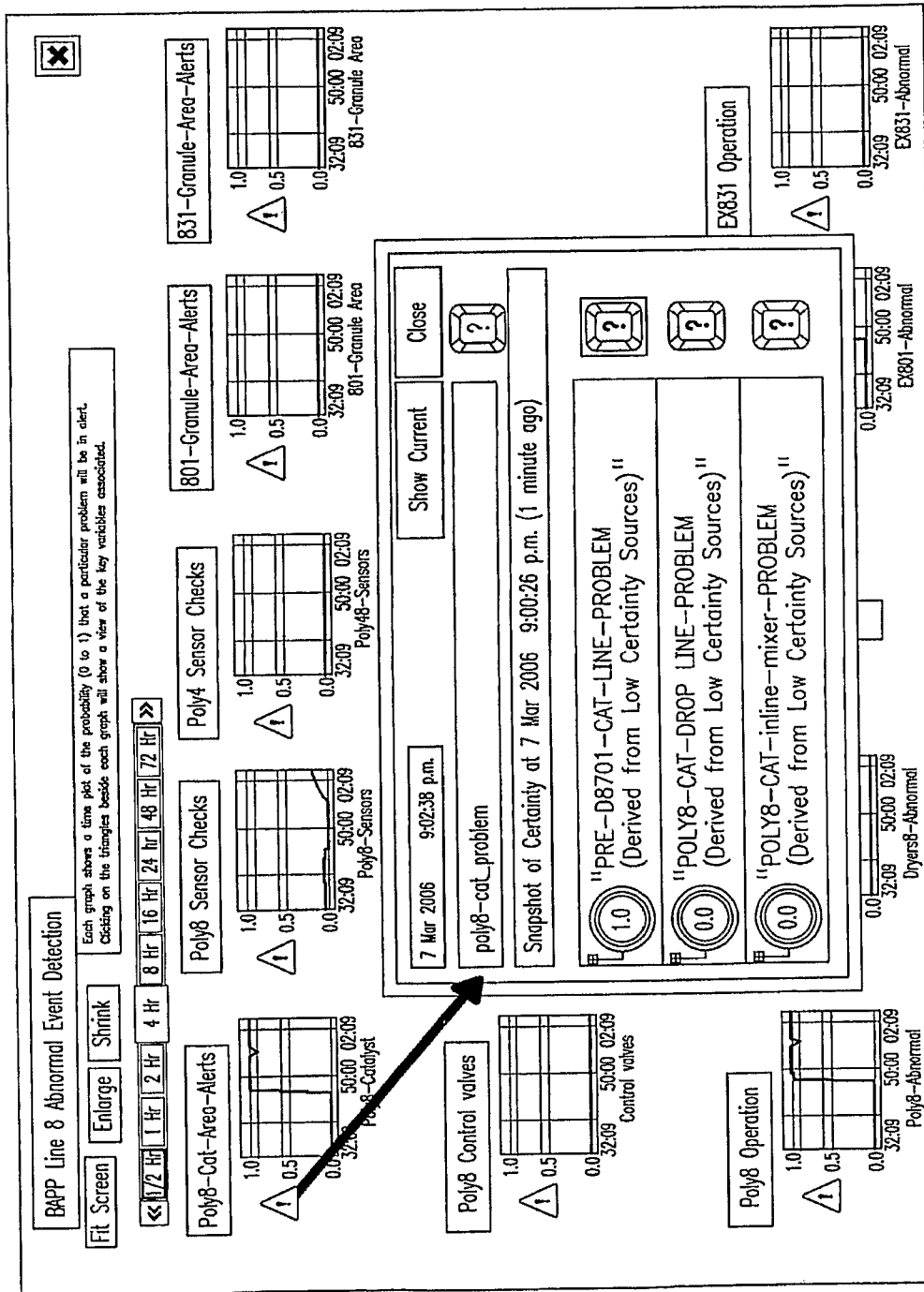

FIG. 28

Fuzzy Logic Network Couple With Rules Developed for Automatic Switching PCA Models Underlying Poly 8 Operation

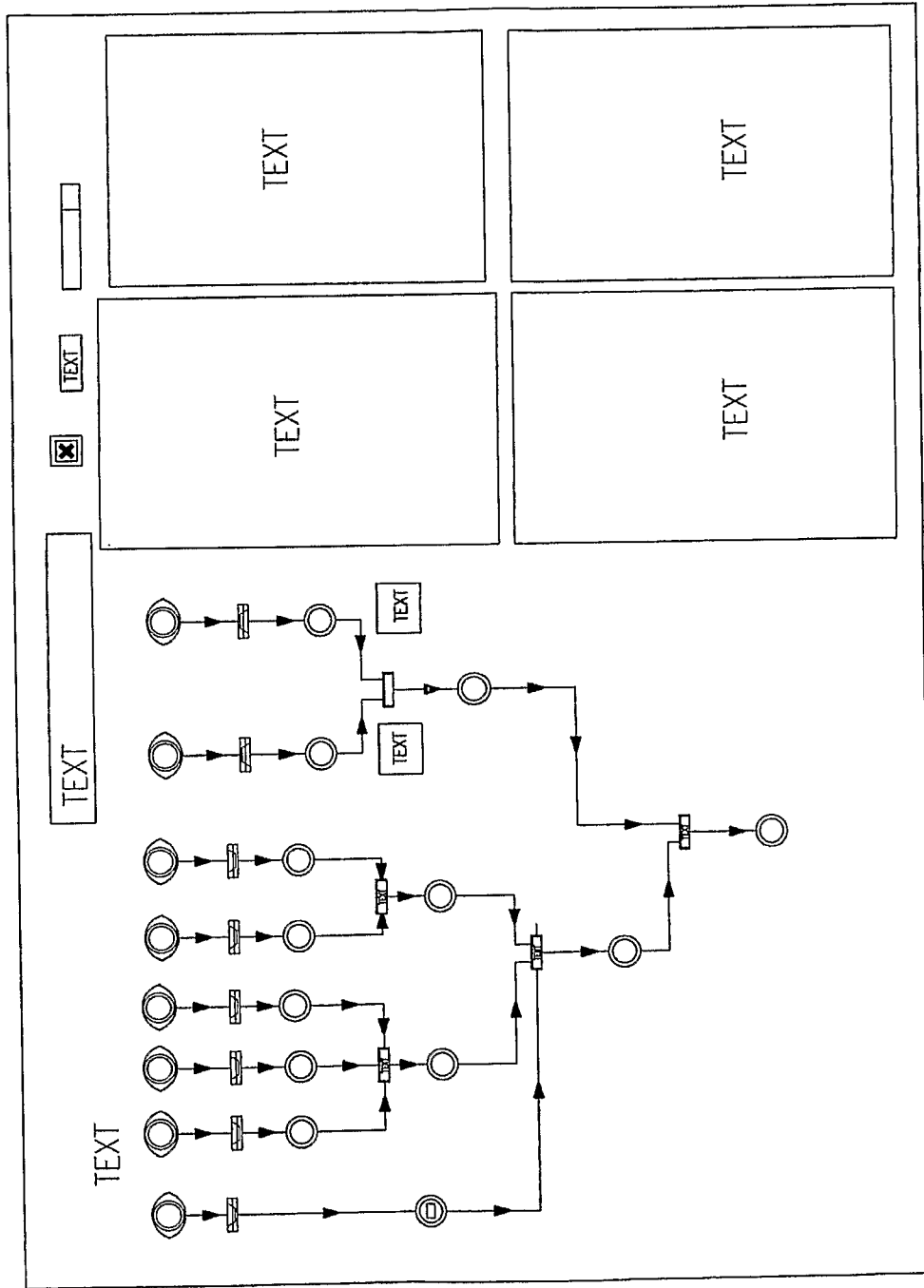

FIG. 30

Fuzzy Logic Network Developed for Automatic Detection of Grade Switches and for Setting Transitional Duration

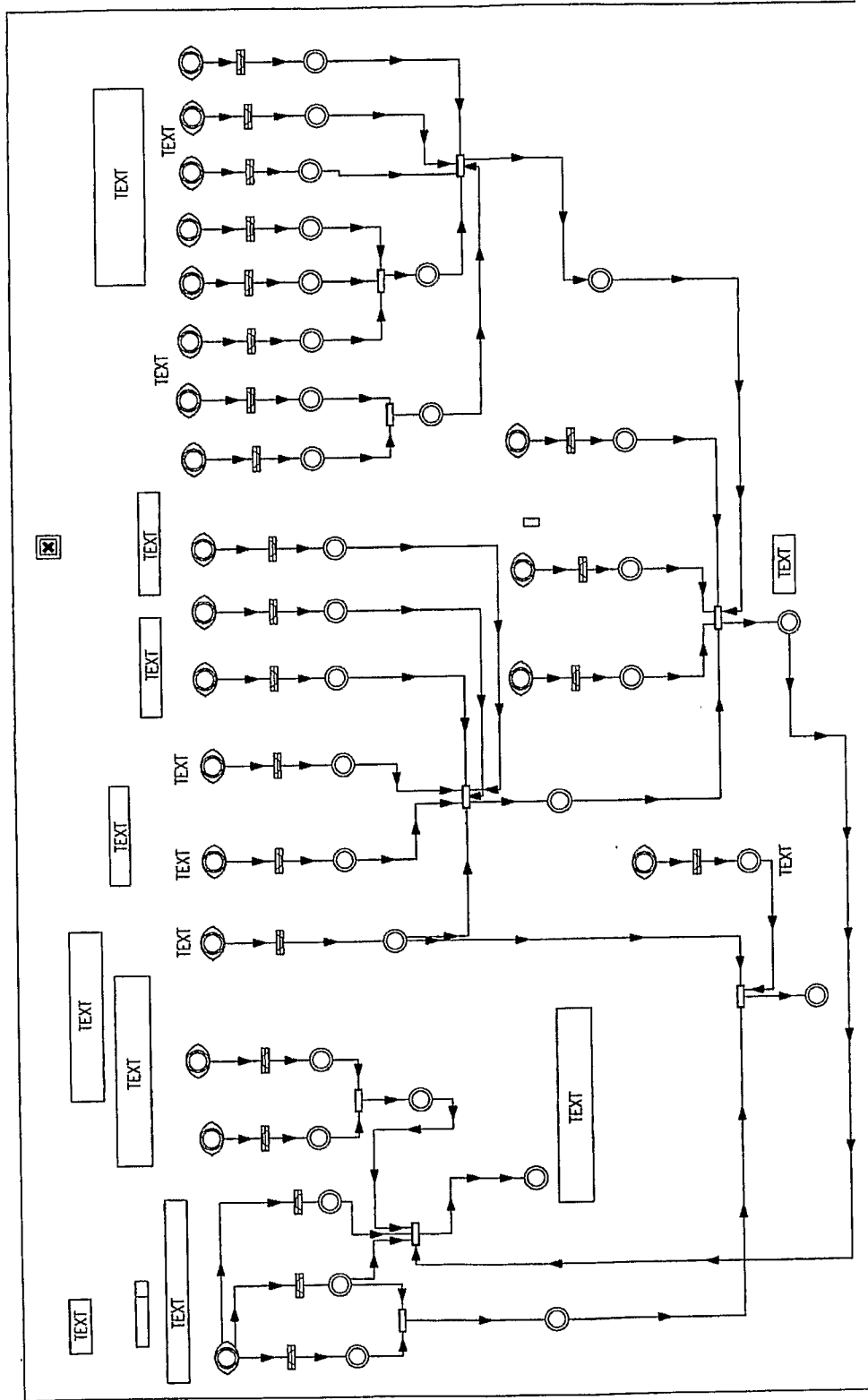

FIG. 31

A PARETO CHART DISPLAYING THE RESIDUALS OF THE DEVIATING SENSORS CORRESPONDING TO THE CATALYST PLUGGING PROBLEM

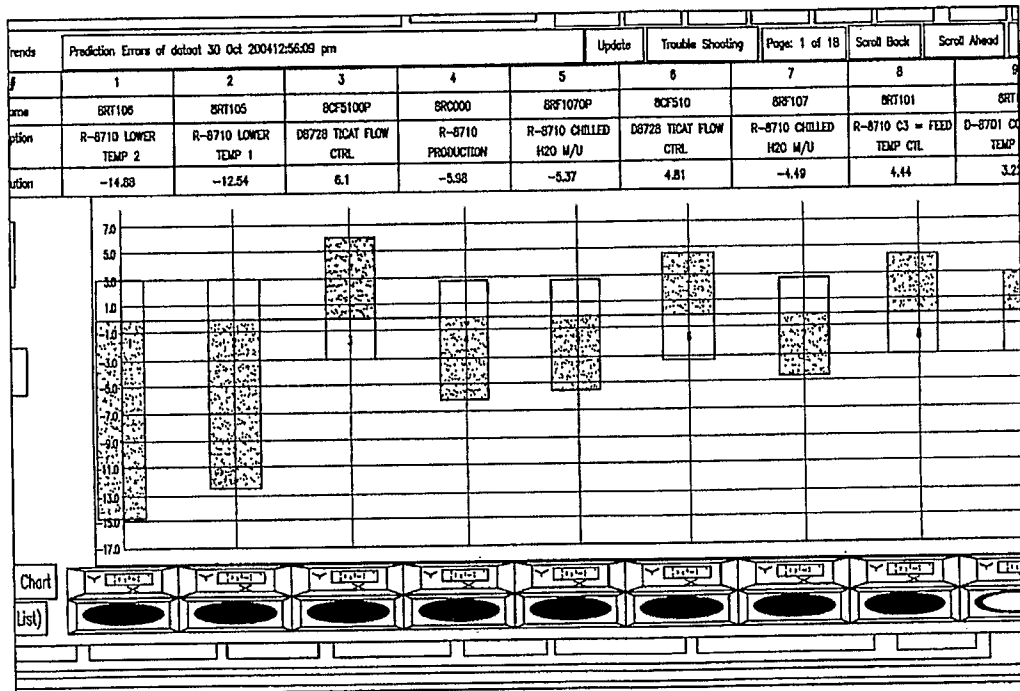

FIG. 32

Trends of the value and model predications of the sensors in the Pareto chart of FIG 32

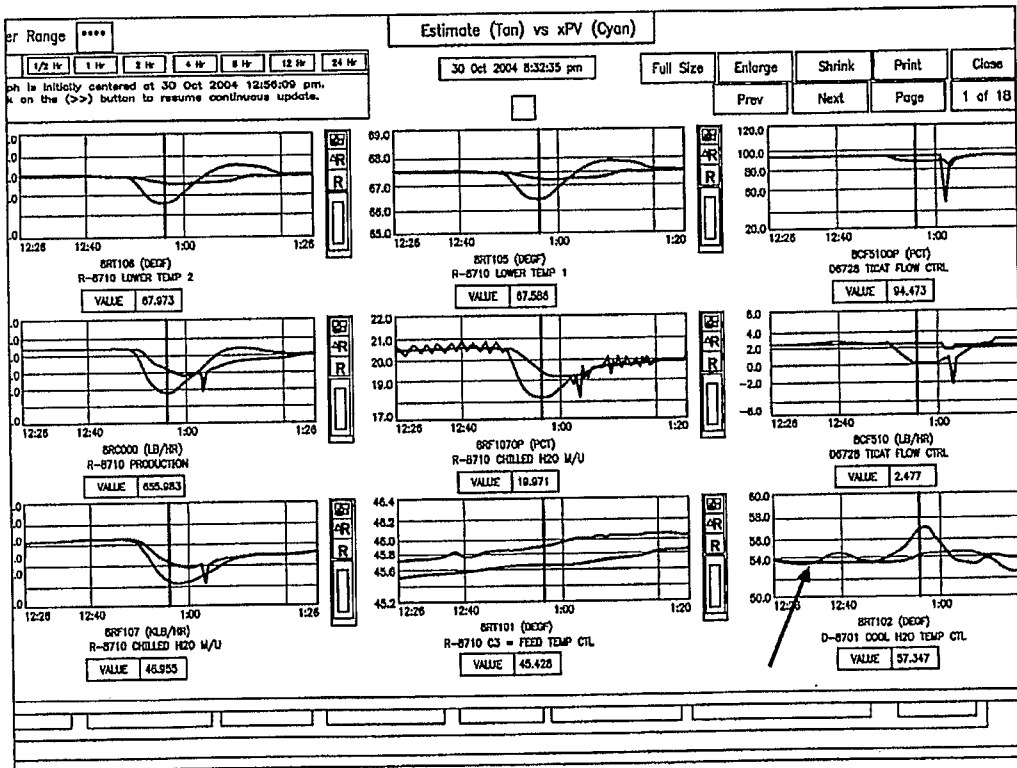

FIG. 33

PARETO CHART OF THE VALVE FLOW MODELS

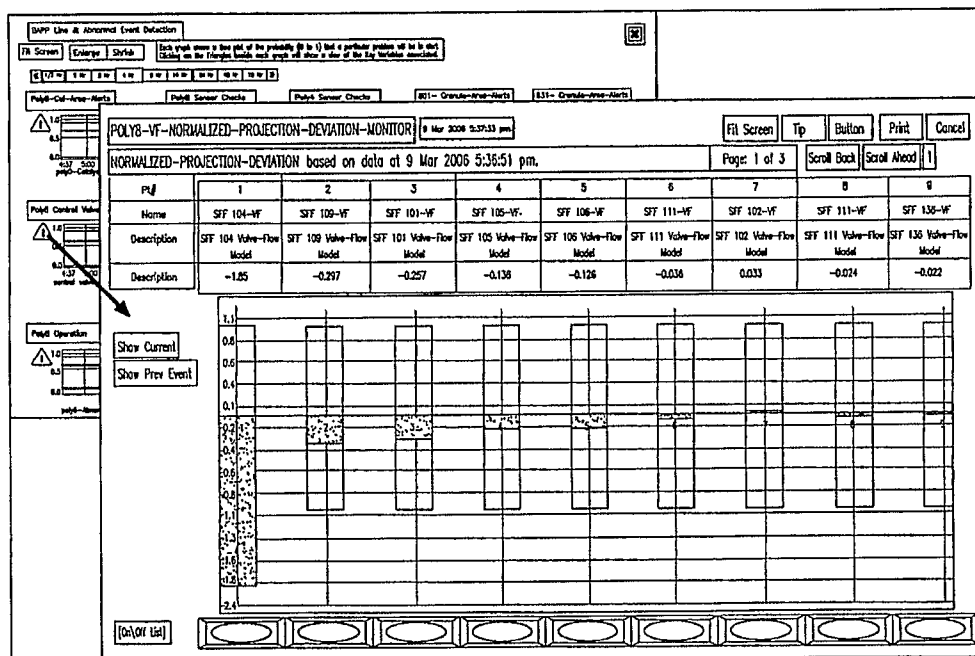

FIG. 34

Valve Flow Model X-Y Plot

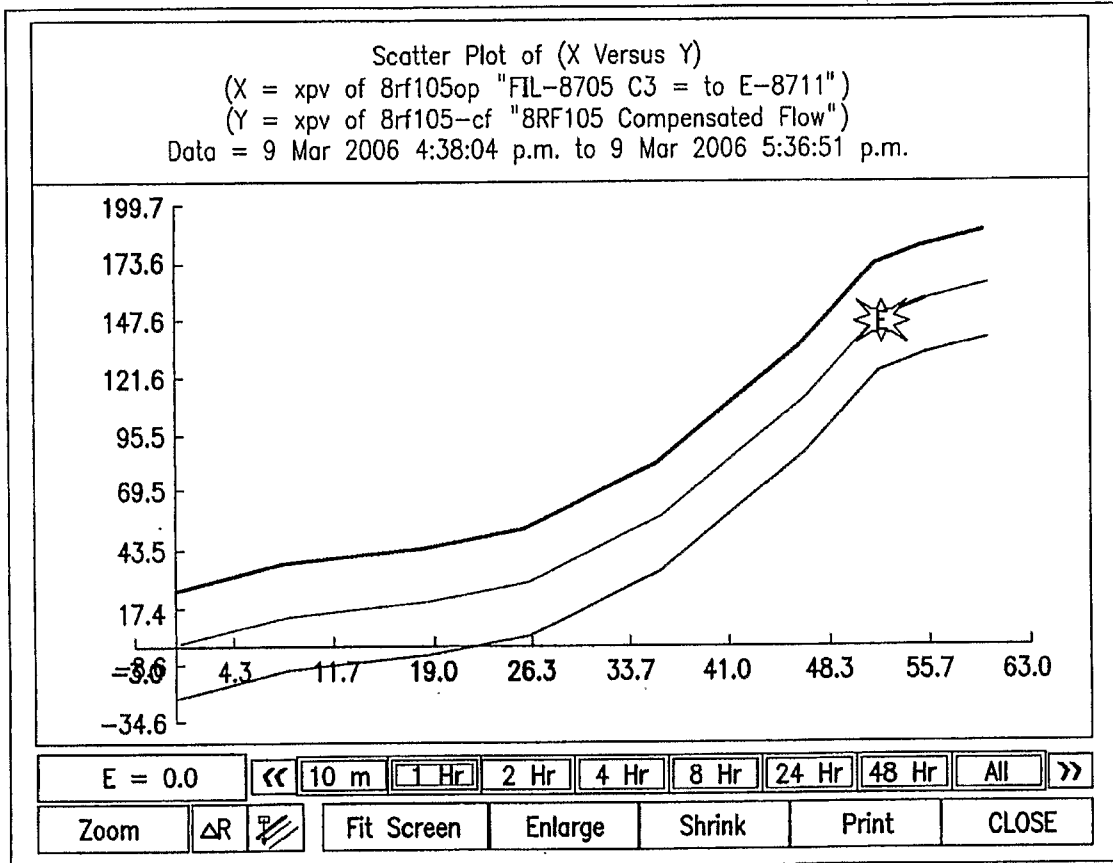

FIG. 35

Drill Down For Controller Monitors and Sensor Checks

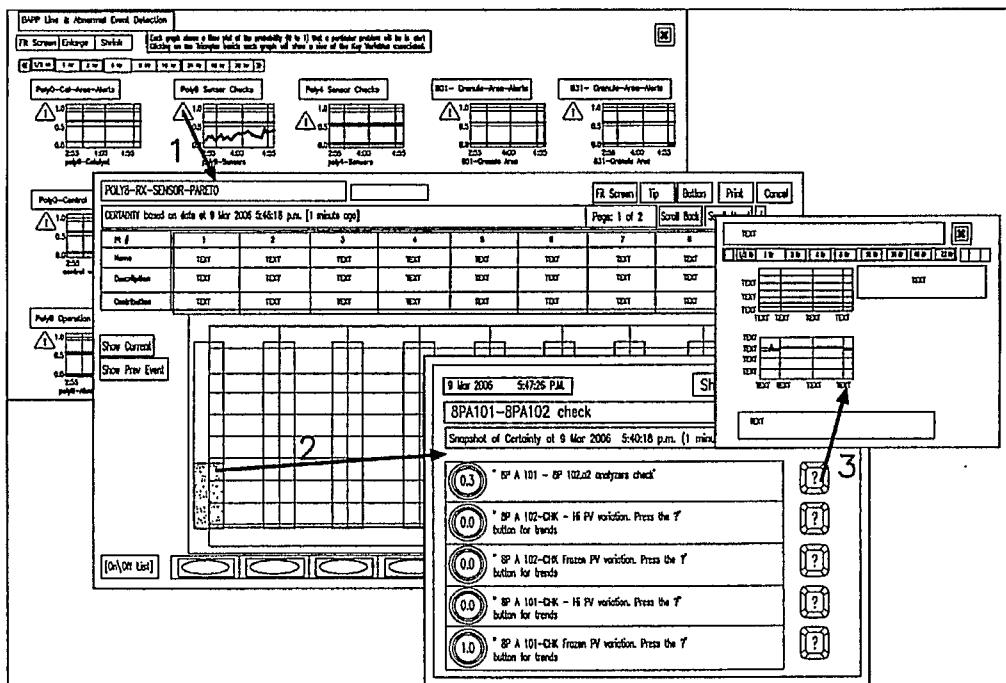

FIG. 36

Fuzzy Logic Network for Controller Monitors and Sensor Checks

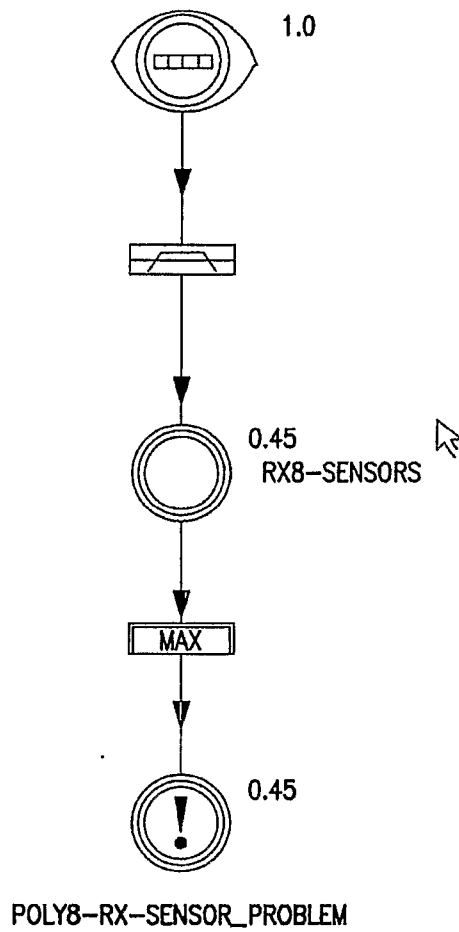

FIG. 37

Drill Down for Heuristic Models

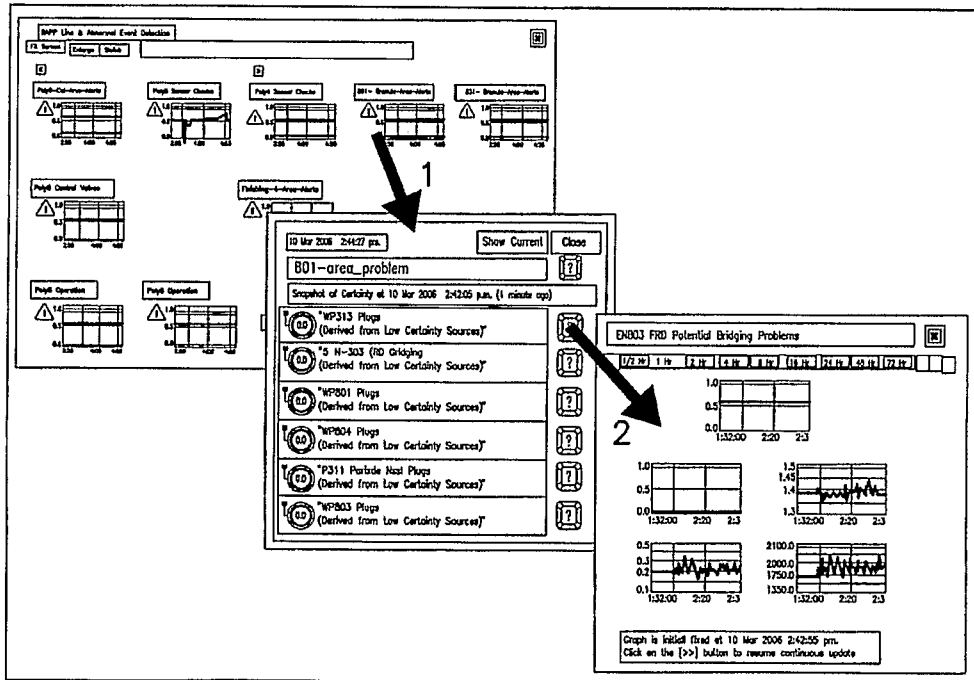

FIG. 38

Fuzzy Logic Network for Heuristic Models

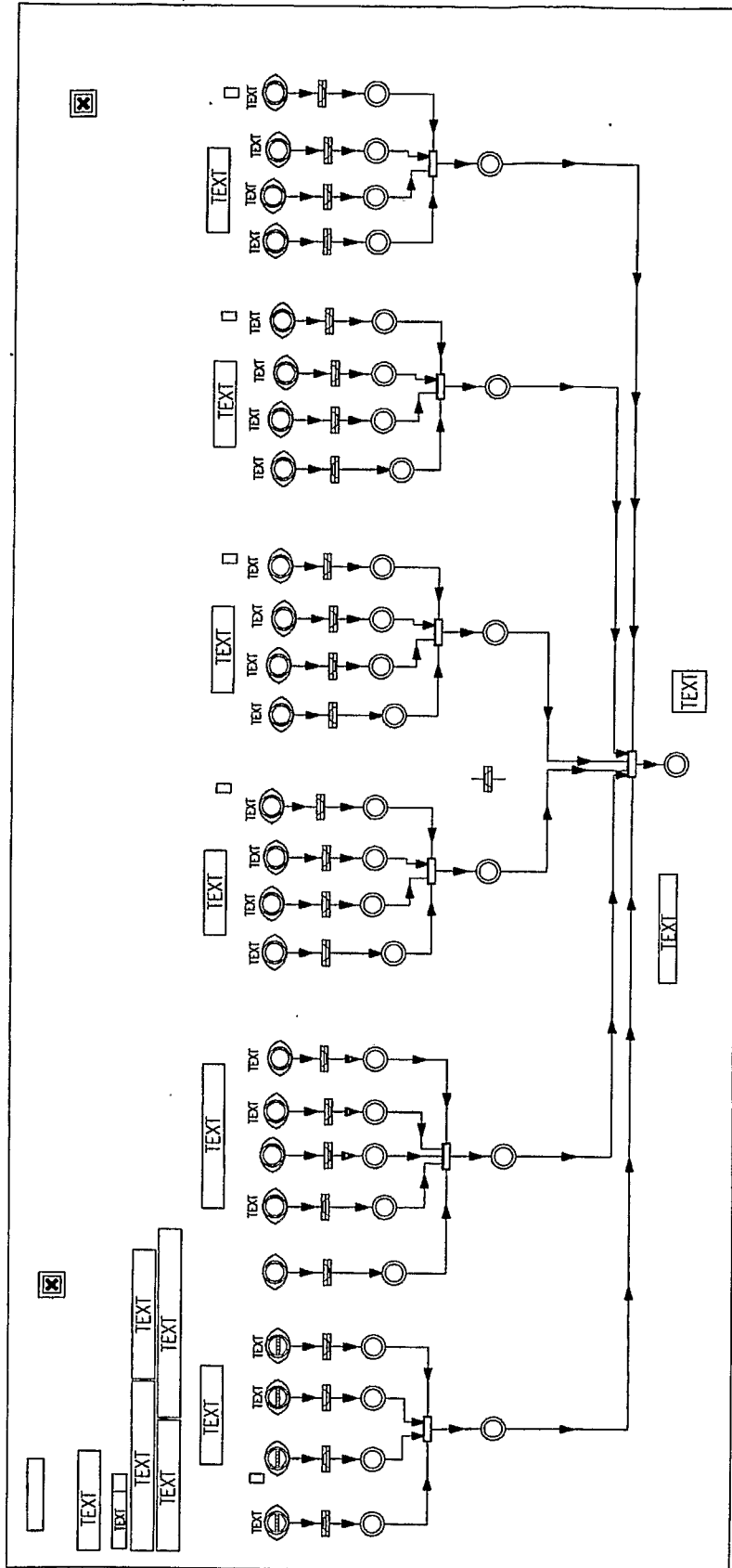

FIG. 39

Example of Valve Out of Controllable Range

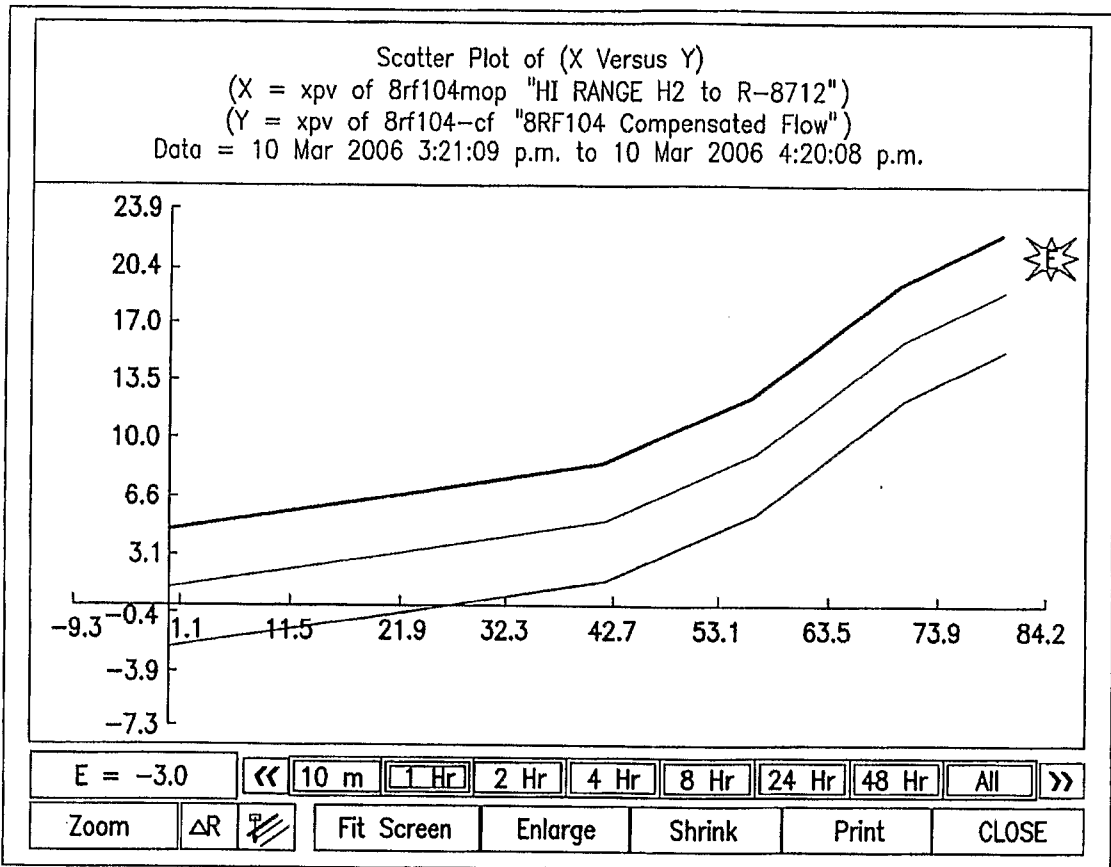

FIG. 40

Valve Flow Model Fuzzy Network

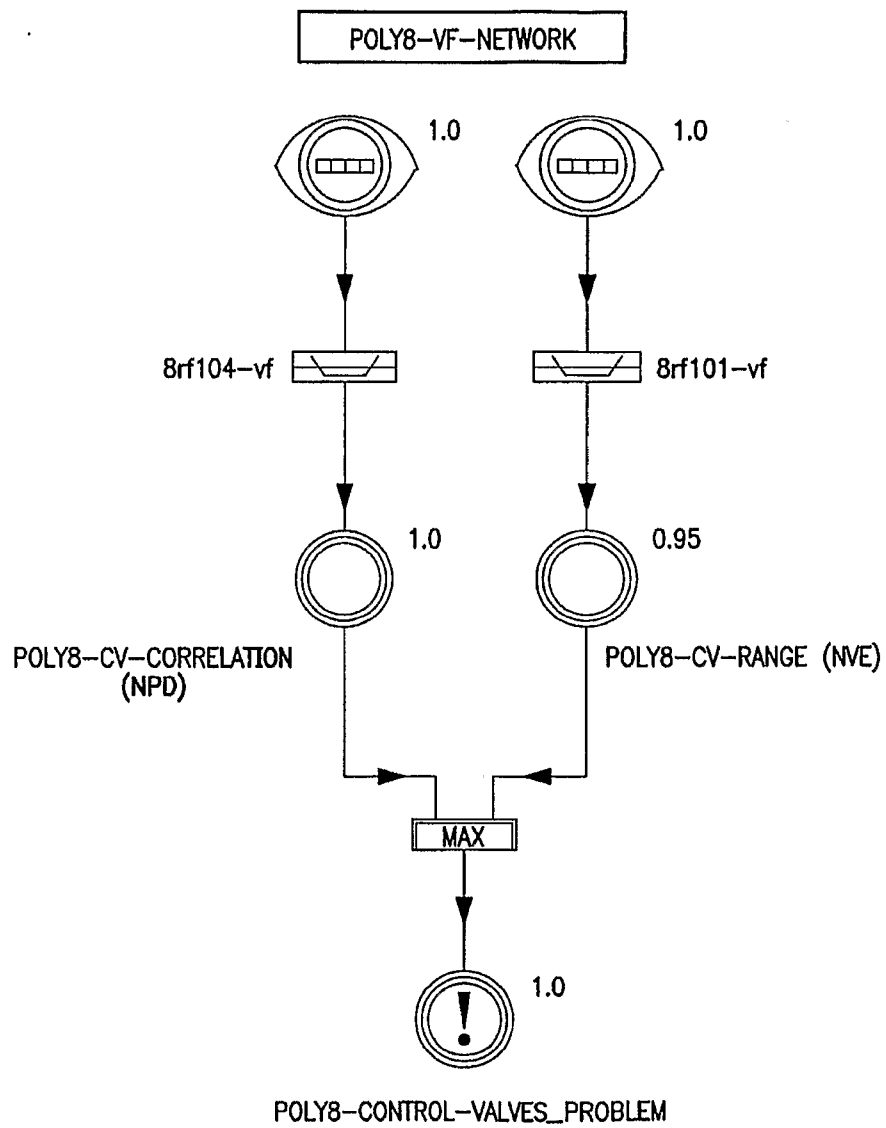

FIG. 41

Building PCA model –Distribution of Principal Components

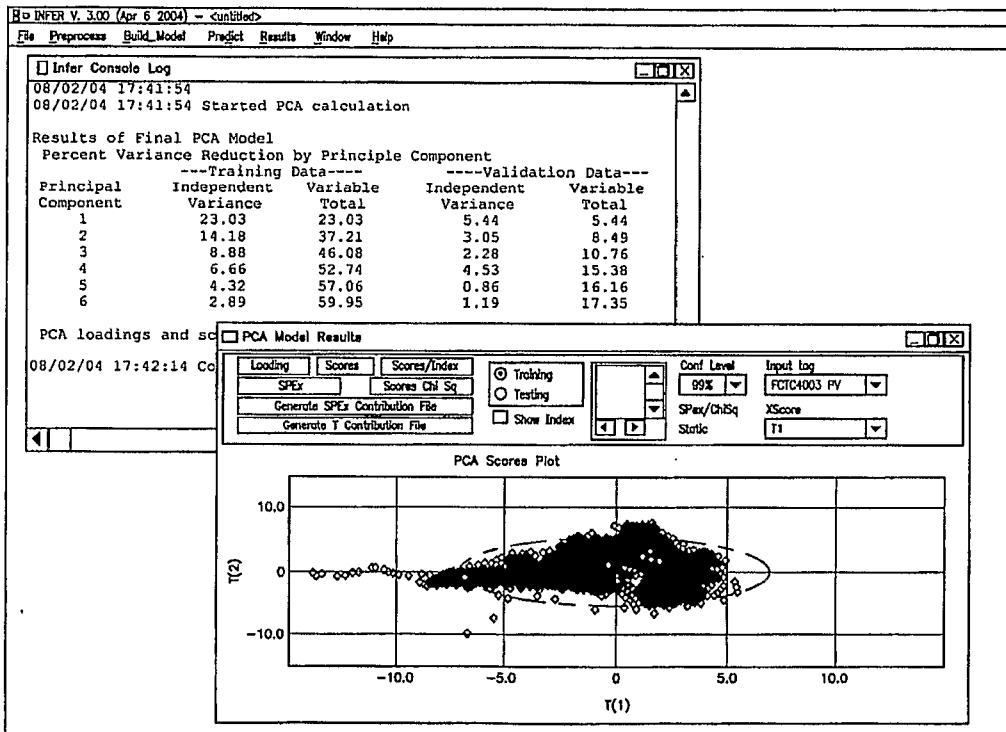

FIG. 42

List of Current Automatic Suppressors

Current Suppressors	<input checked="" type="checkbox"/>
1. 8CH1150P-Sup	9. None
2. 8CH1110P-Sup	10. None
3. ICP-Sup	11. None
4. 8RF112-Sup	12. None
5. 8RF140-Sup	13. None
6. C8754 Sup	14. None
7. 8RF141-Sup	15. None
8. D8727AB Switching	16. None

FIG. 43

AED Event Form

AED Event Log

Date	<input type="text"/>	Time	<input type="text"/>
<u>Check appropriate box</u>			
Poly8_TCR	<input type="checkbox"/>	EX801	<input type="checkbox"/>
Poly8_ICP	<input type="checkbox"/>	EX831	<input type="checkbox"/>
Dryers8	<input type="checkbox"/>	801 Granule	<input type="checkbox"/>
Poly8 Control Valves	<input type="checkbox"/>	831 Granule	<input type="checkbox"/>
Poly8 Cat	<input type="checkbox"/>	803 Granule	<input type="checkbox"/>
Poly8 Sensor Checks	<input type="checkbox"/>	804 Granule	<input type="checkbox"/>
Poly4 Sensor Checks	<input type="checkbox"/>		<input type="checkbox"/>
Alert Severity	<input type="checkbox"/> Yellow	<input type="checkbox"/> Red	
Alert Notification	<input type="checkbox"/> Important	<input type="checkbox"/> Useful	<input type="checkbox"/> Redundant
Agree w/ indication?	<input type="checkbox"/> Yes	<input type="checkbox"/> No	If no, provide comment
Comments	<input type="text"/>		
List key tags involved	<input type="text"/>		
Corrective action taken?	<input type="text"/>		
Suggestions for improvement?	<input type="text"/>		
Name	<input type="text"/>		

FIG. 44