

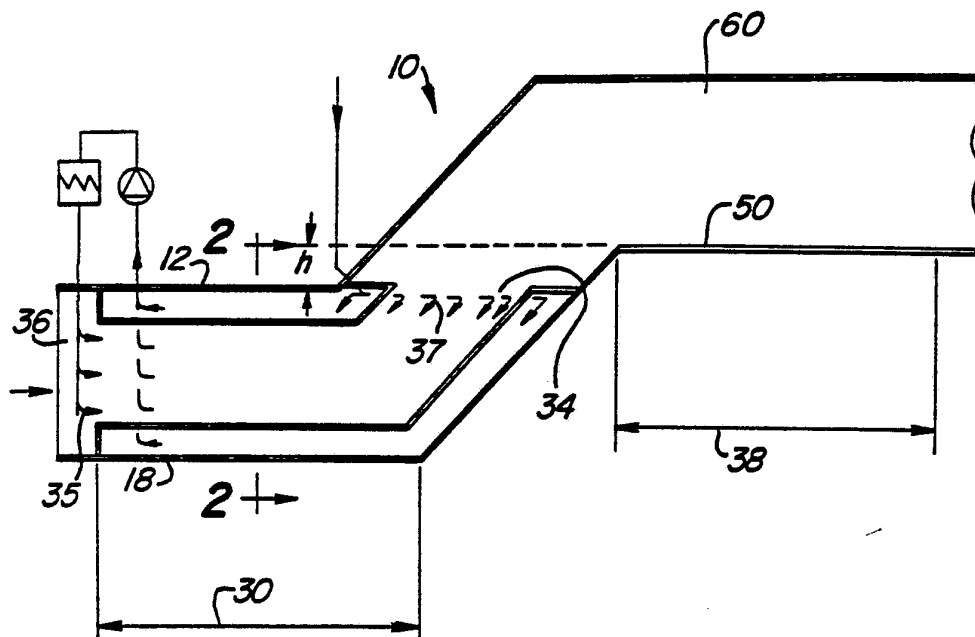

## INTERNATIONAL APPLICATION PUBLISHED UNDER THE PATENT COOPERATION TREATY (PCT)

<p>(51) International Patent Classification <sup>5</sup> : F26B 3/30, 15/00, B05B 15/00 B05D 3/02</p>	A1	<p>(11) International Publication Number: <b>WO 93/05353</b></p> <p>(43) International Publication Date: 18 March 1993 (18.03.93)</p>
<p>(21) International Application Number: PCT/US92/07269</p> <p>(22) International Filing Date: 27 August 1992 (27.08.92)</p> <p>(30) Priority data: 751,718 29 August 1991 (29.08.91) US</p> <p>(71) Applicant: ABB FLAKT, INC. [US/US]; 1400 Stephenson Highway, P.O. Box 4750, Troy, MI 48099-4750 (US).</p> <p>(72) Inventors: JOSEFSSON, Leif, E., B. ; 2245 Tavistock Court, Sterling Heights, MI 48310 (US). PERSSON, Anders, P., A., T. ; Per Lagerquists Vag 7c, S-352 43 Vaxjo (SE).</p> <p>(74) Agent: HARRIS, Gordon, K., Jr.; Harness, Dickey &amp; Pierce, P.O. Box 828, Bloomfield Hills, MI 48303 (US).</p>		<p>(81) Designated States: AT, AU, BB, BG, BR, CA, CH, CS, DE, DK, ES, FI, GB, HU, JP, KP, KR, LK, LU, MG, MN, MW, NL, NO, PL, RO, RU, SD, SE, European patent (AT, BE, CH, DE, DK, ES, FR, GB, GR, IE, IT, LU, MC, NL, SE), OAPI patent (BF, BJ, CF, CG, CI, CM, GA, GN, ML, MR, SN, TD, TG).</p> <p><b>Published</b> <i>With international search report.</i></p>

## (54) Title: PAINT BAKING OVEN WITH INFRARED LAMPS



## (57) Abstract

A first bring up zone of a camel-back oven utilizes a plurality of short and/or medium wave infrared lamps to raise the component temperature up to a desired level. Once within the paint baking oven, the component enters into the bring up zone where a computer activates the requisite number of infrared lamps at the proper intensity to achieve the desired component temperature. While the infrared lamps are activated, inlet air is directed over the lamps to prevent them from overheating. The invention allows for smoother car finishes by preventing bubbling and pops and raises the component temperature more quickly than convectional dark radiation panels.

**FOR THE PURPOSES OF INFORMATION ONLY**

Codes used to identify States party to the PCT on the front pages of pamphlets publishing international applications under the PCT.

AT	Austria	FI	Finland	MN	Mongolia
AU	Australia	FR	France	MR	Mauritania
BB	Barbados	GA	Gabon	MW	Malawi
BE	Belgium	GB	United Kingdom	NL	Netherlands
BF	Burkina Faso	GN	Guinea	NO	Norway
BG	Bulgaria	GR	Greece	NZ	New Zealand
BJ	Benin	HU	Hungary	PL	Poland
BR	Brazil	IE	Ireland	PT	Portugal
CA	Canada	IT	Italy	RO	Romania
CF	Central African Republic	JP	Japan	RU	Russian Federation
CG	Congo	KP	Democratic People's Republic of Korea	SD	Sudan
CH	Switzerland	KR	Republic of Korea	SE	Sweden
CI	Côte d'Ivoire	LI	Liechtenstein	SK	Slovak Republic
CM	Cameroon	LK	Sri Lanka	SN	Senegal
CS	Czechoslovakia	LU	Luxembourg	SU	Soviet Union
CZ	Czech Republic	MC	Monaco	TD	Chad
DE	Germany	MG	Madagascar	TG	Togo
DK	Denmark	ML	Mali	UA	Ukraine
ES	Spain			US	United States of America

Paint baking oven with infrared lamps.

## BACKGROUND OF THE INVENTION

5 1. Field of Invention

This invention relates to bring up zones for paint baking ovens. More particularly, the invention relates to a method and apparatus for distributing infrared radiation within the bring up zone of a camel-back paint baking oven to increase the temperature of components passing therethrough.

10

2. Description of Related Art

Paint baking ovens are used throughout the manufacturing industry to bake the paint or coating applied to various articles such as automobile components. Such paint baking ovens often have conveyors or similar devices for bringing the component to be baked into the paint baking oven and then carrying the component through the various sections or zones of the paint baking oven. Generally, the first section or zone of a paint baking oven is known as a bring up zone. While the component being baked is contained in this bring up zone, a heat source is activated which brings the component's body temperature to a desired level. It is well known in the industry that providing a relatively even body temperature over the entire component gives rise to a more consistent baking which, in turn, results in a more desirable finish.

15

Traditionally, dark radiation panels have been used as the heat source within paint baking oven bring up zones to obtain a more even temperature over the component body. The purpose of the radiant heat bring-up zone is to "skin" the paint coating prior to subjecting it to convection heating in a subsequent holding zone - i.e. to remove any stickiness at the outermost layer of the coating. By the time the painted object leaves such a bring-up zone, most of any solvents in the coating have been driven off by radiant heat. Although some success has been achieved through the use of dark radiation panels as a means of increasing the component's body temperature, it is difficult to control the amount of heat generated over specific areas of the component through the use of dark radiation panels. For example, if the component to be paint baked is an automobile component, it has been discovered that dark radiation panels are a less effective way of heating certain parts such as the roof, bonnet, side doors, wheel houses and other heavy parts because they contain inaccessible hidden surfaces.

25

30

Another drawback in using dark radiation panels within the bring up zone is the excessive amount of time necessary to increase the temperature of larger components to the desired level.

5           None of the art presently known to the applicant utilizes infrared lamps within the bring up zone of a camel-back oven to quickly increase the component's temperature to the desired level.

#### SUMMARY OF THE INVENTION

10           Accordingly, the invention provides a paint baking oven having a camel back design, wherein a first bring up zone is located on a plane below the adjoining paint baking oven section. The components to be baked enter the paint baking oven on a conveyor and are led into a first oven section, which is referred to in the industry as a bring up zone. The component's body temperature is increased while within this bring up  
15 zone by a radiant heat source to begin the paint baking process. After the component's body temperature has been increased to the desired level, the conveyor transfers the component from the bring up zone to a convection air drying section of the oven where the component is baked with the paint coating undergoing a chemical reaction.

Heating means are provided at a first end of the bring up zone which are  
20 operative to increase the temperature of the component contained therein. The heating means comprise a plurality of centrally directed infrared lamps extending from a frame member which selectively projects radiation onto the component as it passes through the leading end of the bring up zone. One of the key features associated with using infrared lamps is that each lamp can be controlled to emit radiation at a selected efficiency  
25 between 0-100%. By controlling the efficiency of each lamp, compensation for differences such as size, shape and the amounts and types of coatings used on the component can be effected.

A feature of the invention is to provide a radiation source which evaporates solvents from inside a paint layer. This internal heating eliminates bubbling  
30 and/or pops from occurring in the paint or coating as the component temperature is increased.

A further feature of the invention is the relative ease by which the painted objects surface temperature is evenly regulated over certain irregularly shaped portions thereof, due to the use of individually controlled infrared lamps.

### BRIEF DESCRIPTION OF PREFERRED EMBODIMENTS

The objects and features of the invention will become apparent from a reading of a detailed description taken in conjunction with the drawings, in which:

FIG. 1 is a cross-sectional side view of a bring up zone arranged in accordance with the principles of the invention.

FIG. 2 is a lateral-sectional view at a first end of the paint baking oven of Fig. 1 showing the bring up zone incorporating infrared lamps.

FIG. 3 is a cross-sectional side view of a camel-back paint baking oven having exhaust means located between a bring up zone and a convection air holding zone.

10

### DETAILED DESCRIPTION OF THE PREFERRED EMBODIMENTS

With reference to Figs. 1, 2, and 3, a paint baking oven 10 includes an outer ceiling 12 and a floor 18 interconnected by two side walls 14 and 16. The paint baking oven 10 is an elongated tunnel having first and second end sections 36 and 37 which are separated approximately at the middle point of the paint baking oven 10 by a parallel hump 60 having a bottom surface or floor 50 located at least 0.5 meters above the ceiling 12 of the two end portions. This height differential of at least 0.5 meters between the first end section and the contiguous raised middle section of the camel-back paint baking oven 10 is essential to the proper operation of the present invention. The height differential is designated  $h$  in FIG. 1.

The articles to be baked move along a conveyor 24 from the sealed entrance end 36 to the sealed exit end 37 throughout the elongated tunnel along a path of travel parallel to the longitudinal axis of the zone or section through which the article is passing. The paint baking oven 10 is used to bake articles which are generally designated by the numeral 22. Although an automobile component has been chosen for demonstrative purposes, it will be understood that the bring up zone 30 of the present invention may be used to raise the temperature of other types of articles in addition to automobile components 22.

The component 22 initially enters the camel-back paint baking oven 10 on a conveyor 24 through an air sealed silhouette located at the entrance end 36 of the paint baking oven 10. Component 22 advances within the paint baking oven 10 upon the conveyor 24 through a first oven section known in the industry as a bring up zone 30.

Bring up zone 30 includes a heating system for increasing the temperature of the component 22 to a desired level. The heating system comprises a combination of

short and/or middle wave infrared lamps 26 (FIG. 2) contained within reflective lamp housings 27 which assist in directing the infrared radiation waves at the component 22. Each of the lamp housings 27 extend inwardly toward the component 22 as it passes through the bring up zone 30 from a frame member 20. Short wave infrared lamps 26 are generally operational over a range of approximately 0.8-2.0 microns and middle wave lamps 26 are generally operational over a range of approximately 2.0-4.0 microns. Ideally, the infrared lamps are operated in a range of between 1.2 and 2.4 microns.

Located between the infrared lamps 26 and the component 22 passing through the bring up zone 30 is an air tight quartz glass wall 28 which protects the lamps from dust, solvents and resins which might be present in the paint baking oven 10. Quartz glass wall 28 also serves to isolate the infrared lamps 26 from the hot air surrounding the painted object in the paint baking oven 10.

The infrared lamps are controlled through time pulsing or TRIAC'S by a computer 40 which make it possible to light specific lamps at specific intensities to accommodate for the variances in the painted surface of the component 22 as it passes through zone 30.

The bring up zone 30 also includes an air inlet system for bringing air into the interior of bring up zone 30. The inlet air flows into the trailing end 34 of the bring up zone 30 as designated by arrows 37 through horseshoe or U-shaped inlets 33 where the air is directed downward towards the entrance end 36 of the bring up zone 30. The inlet air serves to cool the infrared lamps 26 which may be susceptible to overheating. Once the inlet air approaches the entrance end 36 of the bring up zone 30 it is circulated back into the zone 30 by a draft of air designated by arrows 35 entering the leading end 36 of the bring up zone 30 where it can be used to assist in the paint baking process.

With further reference to Figs. 1 and 2, the bring up zone 30 operates in the following manner. Component 22 initially enters the paint baking oven 10 on conveyor 24 through an air sealed silhouette (now shown) located at the entrance end 36 of the paint baking oven 10. Once inside the paint baking oven 10 the component 22 advances along the conveyor 24 at a rate of approximately 10-20 ft./minute along a longitudinal path of travel parallel to the longitudinal axis of the bring up zone 30.

The heating requirements for the particular component are programmed into a computer 40 which is used to individually control the intensity and efficiency of the infrared lamps 26 used to bring the component's temperature to the desired level. The computer 40 is programmed to take into account various factors such as the size, shape

and the material make up of the component 22 being heated. The computer program also accounts for the absorption factor of the paint which is applied to the component 22. For example, top coat lines of silver metallic paint have the lowest absorption factor and black solids have the highest absorption factor. The computer 40 is, therefore, programmed to  
5 operate the infrared lamps 26 on high power at 100% efficiency when the component 22 is coated with silver metallic paint and to reduce the power and/or the efficiency of the infrared lamps 26 through time pulsing or TRIAC'S for components 22 coated with paints possessing a higher absorption factor.

As the components 22 pass through the leading end 36 of the convection  
10 air holding zone 30, the infrared lamps 26 are activated by the computer 40, according to the control specifications entered therein, to heat the component 22 to the desired level prior to a more intense baking within the convection air holding zones such as zone 38 of Fig. 3. The radiation emitted by the infrared lamps passes through the quartz glass wall 28 and is directed upon component 22 until the desired component temperature is  
15 attained.

One advantage in using infrared lamps 26 is that the radian heat penetrates the outer paint surface and bakes the coating from the inside out, heating the innermost layers progressively outwardly toward the skin dried outermost layer.

The invention has been described with reference to a detailed description  
20 of a preferred embodiment given for the sake of example only. The scope and spirit of the invention are to be determined by the appended claims.

CLAIMS

What is claimed:

1. In a camel-back paint baking oven having a conveyor for transporting articles therethrough, wherein a first bring up zone includes a top surface located on a parallel plane at least 0.5 meters below a bottom surface of an adjacent paint baking oven section, the improvement comprising:  
radiant heating means located at a first end of said bring up zone, and operative to increase the temperature of the article to be baked.
2. The improvement of Claim 1 wherein the radiant heating means comprises a plurality of infrared lamps.
3. The improvement of claim 2 wherein said infrared lamps further comprise a combination of short and middle wave infrared lamps positioned upon a frame member located within said bring up zone and arranged such that said lamps face inward toward the center of said bring up zone.
4. The improvement of claim 1 further comprising stored program control means operative to control a temperature of the radiant heating means.
5. The improvement of claim 3 wherein said short wave infrared lamps operate in a range of between 0.8 and 2.0 microns.
6. The improvement of claim 3 wherein said middle wave infrared lamps operate in a range of between 2.0 and 4.0 microns.
7. The improvement of claim 3 wherein said infrared lamps are operated in a range of between 1.2 and 2.4 microns.
8. The improvement of claim 2 wherein said infrared lamps are provided with reflector means which direct the radiation produced by said lamps toward articles as they pass through said bring up zone.

1/2

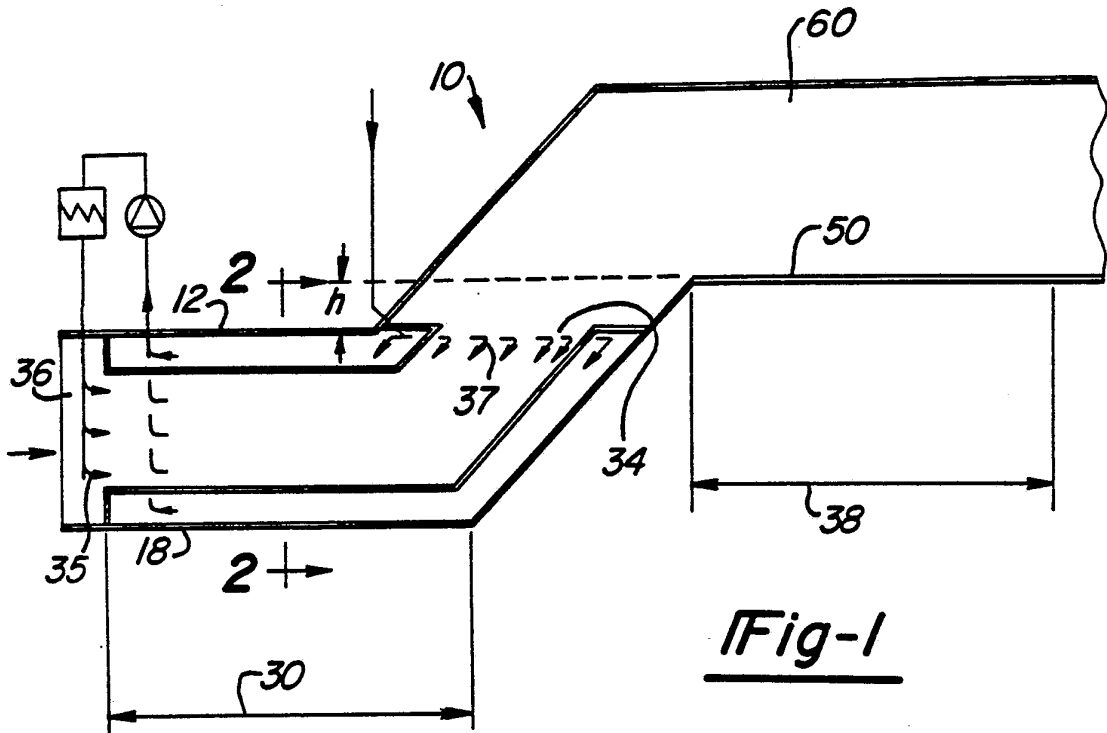
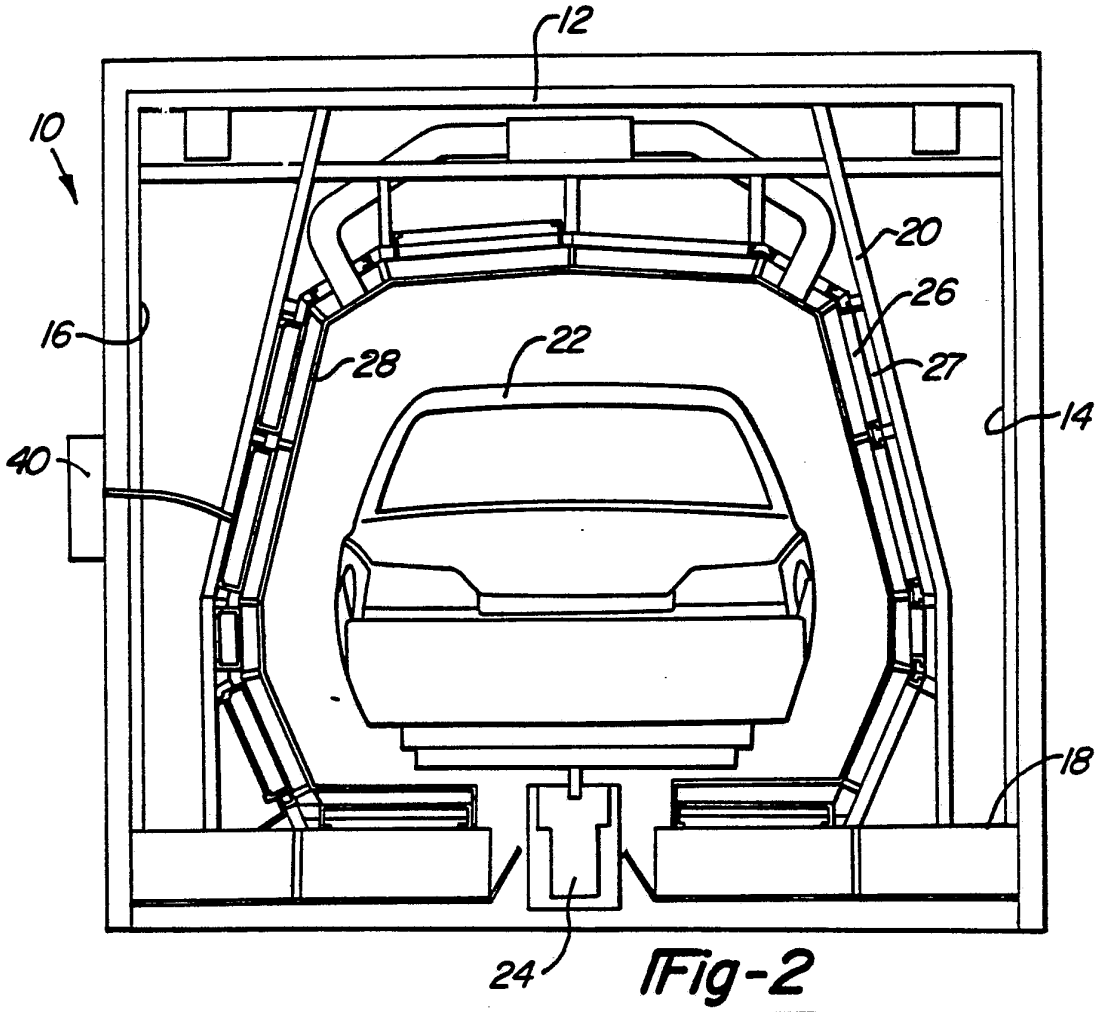

Fig-1



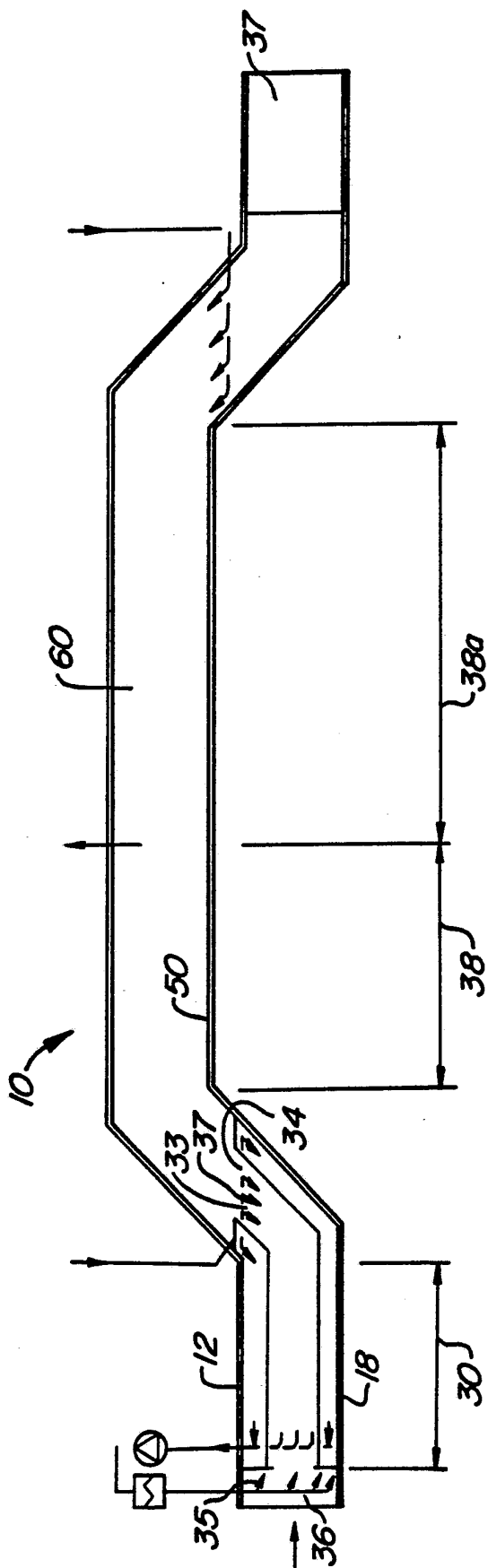

Fig-3

# INTERNATIONAL SEARCH REPORT

International Application No PCT/US 92/07269

<b>I. CLASSIFICATION OF SUBJECT MATTER</b> (if several classification symbols apply, indicate all) <sup>6</sup>		
According to International Patent Classification (IPC) or to both National Classification and IPC		
IPC5: F 26 B 3/30, 15/00, B 05 B 15/00, B 05 D 3/02		
<b>II. FIELDS SEARCHED</b>		
Minimum Documentation Searched <sup>7</sup>		
Classification System	Classification Symbols	
IPC5	B 05 B; B 05 D; F 26 B	
Documentation Searched other than Minimum Documentation to the Extent that such Documents are Included in Fields Searched <sup>8</sup>		
<b>III. DOCUMENTS CONSIDERED TO BE RELEVANT<sup>9</sup></b>		
Category *	Citation of Document, <sup>11</sup> with indication, where appropriate, of the relevant passages <sup>12</sup>	Relevant to Claim No. <sup>13</sup>
A	WO, A1, 8701186 (TRI INNOVATIONS AB) 26 February 1987, see page 1, line 14 - line 19; abstract; claim 1  --	1-2
A	EP, A1, 0203377 (BAYERISCHE MOTOREN WERKE) 3 December 1986, see abstract; claim 1  --	1-2
A	WO, A1, 8503766 (BERKMANN, ADOLF) 29 August 1985, see abstract; claim 1  --	1-2
<p>* Special categories of cited documents:<sup>10</sup></p> <p>"A" document defining the general state of the art which is not considered to be of particular relevance</p> <p>"E" earlier document but published on or after the international filing date</p> <p>"L" document which may throw doubts on priority claim(s) or which is cited to establish the publication date of another citation or other special reason (as specified)</p> <p>"O" document referring to an oral disclosure, use, exhibition or other means</p> <p>"P" document published prior to the international filing date but later than the priority date claimed</p> <p>"T" later document published after the international filing date or priority date and not in conflict with the application but cited to understand the principle or theory underlying the invention</p> <p>"X" document of particular relevance, the claimed invention cannot be considered novel or cannot be considered to involve an inventive step</p> <p>"Y" document of particular relevance, the claimed invention cannot be considered to involve an inventive step when the document is combined with one or more other such documents, such combination being obvious to a person skilled in the art.</p> <p>"&amp;" document member of the same patent family</p>		
<b>IV. CERTIFICATION</b>		
Date of the Actual Completion of the International Search		Date of Mailing of this International Search Report
7th December 1992		18 DEC 1992
International Searching Authority		Signature of Authorized Officer
EUROPEAN PATENT OFFICE		Johan von Döbeln

III. DOCUMENTS CONSIDERED TO BE RELEVANT - (CONTINUED FROM THE SECOND SHEET)		
Category *	Citation of Document, with indication, where appropriate, of the relevant passages	Relevant to Claim No
A	US, A, 4635381 (GORDON F. HUBBERT) 13 January 1987, see abstract  -----  -----	1-2

**ANNEX TO THE INTERNATIONAL SEARCH REPORT  
ON INTERNATIONAL PATENT APPLICATION NO.PCT/US 92/07269**

SA 64536

This annex lists the patent family members relating to the patent documents cited in the above-mentioned international search report. The members are as contained in the European Patent Office EDP file on 30/10/92. The European Patent office is in no way liable for these particulars which are merely given for the purpose of information.

Patent document cited in search report	Publication date	Patent family member(s)	Publication date
WO-A1- 8701186	26/02/87	EP-A- 0270548	15/06/88
		SE-B-C- 453222	18/01/88
		SE-A- 8503813	16/02/87
EP-A1- 0203377	03/12/86	DE-C- 3515600	09/10/86
WO-A1- 8503766	29/08/85	CA-A- 1230273	15/12/87
		DE-C- 3406789	31/10/85
		DE-A- 3562824	23/06/88
		EP-A-B- 0154265	11/09/85
		EP-A- 0174351	19/03/86
		JP-T- 61501082	29/05/86
US-A- 4635381	13/01/87	CA-A- 1200378	11/02/86
		US-A- 4733481	29/03/88

For more details about this annex : see Official Journal of the European patent Office, No. 12/82