



- (51) **International Patent Classification:**
B01L 7/00 (2006.01) *B01L 3/00* (2006.01)
- (21) **International Application Number:**
PCT/KR2019/007858
- (22) **International Filing Date:**
28 June 2019 (28.06.2019)
- (25) **Filing Language:** English
- (26) **Publication Language:** English
- (30) **Priority Data:**
10-2018-0074957 28 June 2018 (28.06.2018) KR
- (71) **Applicant: SEEGENE, INC.** [KR/KR]; (Taewon Bldg., Bangi-dong) 8F 9F, 91, Ogeum-ro, Songpa-gu, Seoul 05548 (KR).
- (72) **Inventors: SONG, Hae-Sung;** 303 Jibaek Villa, 33, Dongsan-ro 8-gil, Seocho-gu, Seoul 06784 (KR). **YANG, Boo Hyun;** 111-1901, 81, Beoman-ro, Sosa-gu, Bucheon-si, Gyeonggi-do 14783 (KR).
- (74) **Agent: YUIL HIGHEST INTERNATIONAL PATENT AND LAW FIRM;** (Oksan Bldg., Yeoksam-dong) 2F, 59, Gangnam-daero 94-gil, Gangnam-gu, Seoul 06130 (KR).
- (81) **Designated States** (*unless otherwise indicated, for every kind of national protection available*): AE, AG, AL, AM, AO, AT, AU, AZ, BA, BB, BG, BH, BN, BR, BW, BY, BZ, CA, CH, CL, CN, CO, CR, CU, CZ, DE, DJ, DK, DM, DO,

DZ, EC, EE, EG, ES, FI, GB, GD, GE, GH, GM, GT, HN, HR, HU, ID, IL, IN, IR, IS, JO, JP, KE, KG, KH, KN, KP, KR, KW, KZ, LA, LC, LK, LR, LS, LU, LY, MA, MD, ME, MG, MK, MN, MW, MX, MY, MZ, NA, NG, NI, NO, NZ, OM, PA, PE, PG, PH, PL, PT, QA, RO, RS, RU, RW, SA, SC, SD, SE, SG, SK, SL, SM, ST, SV, SY, TH, TJ, TM, TN, TR, TT, TZ, UA, UG, US, UZ, VC, VN, ZA, ZM, ZW.

(84) **Designated States** (*unless otherwise indicated, for every kind of regional protection available*): ARIPO (BW, GH, GM, KE, LR, LS, MW, MZ, NA, RW, SD, SL, ST, SZ, TZ, UG, ZM, ZW), Eurasian (AM, AZ, BY, KG, KZ, RU, TJ, TM), European (AL, AT, BE, BG, CH, CY, CZ, DE, DK, EE, ES, FI, FR, GB, GR, HR, HU, IE, IS, IT, LT, LU, LV, MC, MK, MT, NL, NO, PL, PT, RO, RS, SE, SI, SK, SM, TR), OAPI (BF, BJ, CF, CG, CI, CM, GA, GN, GQ, GW, KM, ML, MR, NE, SN, TD, TG).

Published:
— with international search report (Art. 21(3))

(54) **Title:** THERMAL BLOCK

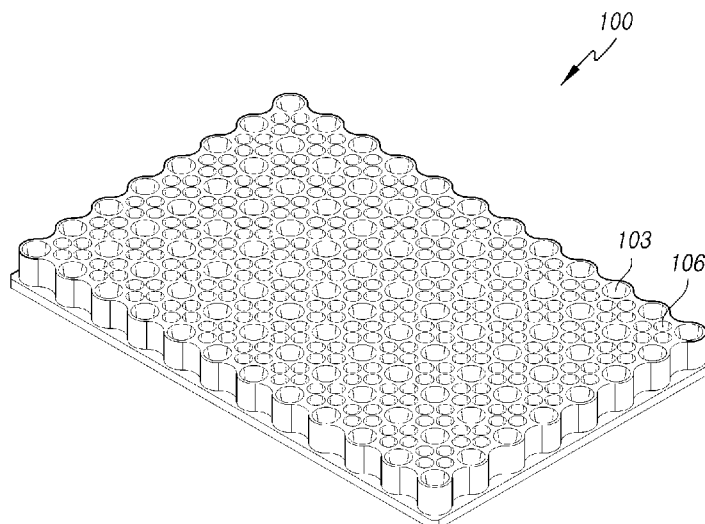

(57) **Abstract:** The present disclosure relates to a thermal block for performing a plurality of reactions. In the thermal block, a plurality of sample wells are regularly arranged, and non-sample holes smaller than the sample wells are provided. Two or more non-sample holes are provided in a unit area defined by connecting central points of four adjacent sample wells among the plurality of sample wells in the thermal block. The thermal block prevents an error in which a reaction vessel may be erroneously fitted while minimizing the amount of thermal energy necessary to change the temperature thereof. The thermal block has superior durability to conventional thermal blocks.



Description

Title of Invention: THERMAL BLOCK

Technical Field

[1] The present disclosure relates to a thermal block for performing a plurality of reactions.

[2]

Background Art

[3] The most commonly used process in nucleic acid amplification, commonly known as polynucleotide chain reaction (PCR), is based on repeated cycles of double-stranded DNA denaturation, oligonucleotide primer annealing to DNA template strands, and primer extension by a DNA polymerase (United States Patent Nos. 4,683,195, 4,683,202, and 4,800,159, Mullis et al.; and (1985) Science 230, 1350-1354, Saiki et al.).

[4] Clinical laboratory or the like, examining specimens collected from a number of patients, perform simultaneous parallel nucleic acid amplification processes on a plurality of samples using a reaction mixture having a fixed composition according to fixed reaction conditions in order to detect the same target nucleic acid from the plurality of samples. Thus, PCR instruments, used to detect target nucleic acids from samples, are designed to be able to simultaneously amplify a plurality of samples. For example, PCR instruments may include a thermal block able to accommodate a plurality of reaction vessels (or tubes) therein. PCR instruments may also include an apparatus and a control system able to rapidly change and uniformly maintain the temperatures of thermal block wells (i.e. recesses formed therein for accommodating reaction vessels). A program able to read and comprehensively report test results performed in the plurality of wells may be provided. In addition, a reaction plate, in which a plurality of reaction vessels usable in PCR instruments are connected together, has been developed and used.

[5] A thermal block, also referred to as a heating block, may include a plurality of wells able to accommodate a plurality of reaction vessels therein, and is fabricated of a metal suitable for rapid heat conduction. However, since metal has high specific gravity and specific heat, a large amount of energy may need to be supplied or removed to adjust the temperature of the thermal block, which is problematic.

[6] In order to overcome such a problem, United States Patent Nos. 7,955,573, 7,632,464, and 8,557,196 disclose solutions of forming holes in side and top surfaces of a thermal block. These solutions are intended to more rapidly change the temperature of the thermal block by removing non-essential portions from the thermal

block. However, there has been a problem in that users may place a reaction plate on the holes formed in the top surface. In order to overcome this problem, there has been developed a thermal block, in which a hole, located in the center of the thermal block, from among the plurality of holes formed in the top surface, is removed.

[7] However, such a configuration fails to solve the problem of erroneous mounting of a reaction plate occupying a portion of the space of the thermal block, such as a single PCR tube or a strip of eight (8)-PCR tubes. Furthermore, since the patterns of mass-reducing holes provided in the thermal block are non-uniform, differences in temperature may occur among the reaction plates or the plurality of reaction tubes accommodated in the wells, which is also problematic.

[8] PCR is a reaction of amplifying a target nucleic acid sequence by repeating steps of hybridizing a specific primer to a target nucleic acid sequence, extending resultant hybrids, and subsequently separating extended strands. The PCR reaction is a method of maintaining the reaction mixture at designated temperatures for set periods of time. Thus, in the PCR reaction, it is extremely important to maintain accurate temperatures in respective steps. Reaction efficiencies in respective steps may vary depending on the temperature.

[9] In particular, in a case in which the same examination is being performed on a plurality of samples using the PCR reaction, differences in temperature continuously occurring among the wells may be reasons for which the plurality of samples subjected to the amplification reaction in different wells have different efficiencies. Since the PCR reaction repeats tens of cycles of nucleic acid amplification, and a DNA strand generated in a cycle serves as a DNA template in the subsequent cycle, amplification efficiency differences occurring in the respective cycles may have a significant effect on the result of analysis.

[10] In addition, United States Patent No. 7,081,600 discloses a thermal block in which inverted conical sample wells connected to a bottom backing are arranged in a predetermined pattern. In the thermal block having such a structure, all of the top portions of the sample wells are independently disconnected from each other. In this case, physical durability may be deteriorated, while a mass reduction effect may be increased.

[11] In order to preserve materials in the high-temperature tubes and prevent caps of the reaction tubes from being opened during the PCR process, PCR instruments may include hot lids (or high-temperature lids) that may be pressed against the top portions of the reaction tubes so as not to be opened. The hot lids remain in close contact with the top ends of the reaction tubes while being pressed against the reaction tubes. Pressing force applied in this manner may be transferred to the thermal block through the reaction vessels, thereby deforming the thermal block. The weaker the horizontal connection between the sample wells is, the lower the durability of the sample wells

may be. In particular, if the hot lid is closed with a plate or a reaction tube being erroneously fitted, the sample well of the thermal block may be deformed or fractured.

[12] Accordingly, there has been demand for the development of a novel thermal block having superior durability while being able to minimize differences in temperature in a reaction plate or among a plurality of reaction tubes and prevent an accident in which a reaction plate is erroneously fitted.

[13]

Disclosure of Invention

Technical Problem

[14] Accordingly, the present disclosure has been made in consideration of the above-described problems occurring in the related art, and the present disclosure proposes a thermal block having superior durability while having a uniform pattern of non-sample holes and being able to prevent the problem of erroneous fitting of a reaction plate.

[15]

Solution to Problem

[16] According to an aspect of the present disclosure, provided is a thermal block for performing a plurality of reactions.

[17] The thermal block may include:

[18] a top surface and a bottom surface having a length and a width and being parallel to each other;

[19] a plurality of sample wells provided in the top surface to be open upwardly, the plurality of sample wells being in a regular array; and

[20] two or more non-sample holes provided in the top surface to be open upwardly, an open area of each of the non-sample holes being smaller than an open area of each of the sample wells,

[21] wherein the two or more non-sample holes are provided in a unit area defined by connecting central points of four adjacent sample wells among the plurality of sample wells in the thermal block.

[22]

Advantageous Effects of Invention

[23] The thermal block according to the present disclosure can prevent an error in which a reaction vessel is erroneously fitted while minimizing the amount of thermal energy necessary to change the temperature thereof, by removal of unnecessary portions therefrom.

[24] The thermal block according to the present disclosure can prevent an error in which a reaction vessel is erroneously fitted, since the open area of each of the non-sample holes, provided to reduce the unnecessary mass of the thermal block, is smaller than

the open area of each of the sample wells.

[25] In addition, the thermal block according to the present disclosure has the two or more non-sample holes in the unit area, so that the reduction of the unnecessary mass thereof can be maximized, while the non-sample holes smaller than the sample wells are used.

[26] In addition, the two or more non-sample holes provided in the unit areas in the thermal block have the same patterns, so that differences in temperature among the sample wells can be reduced.

[27] The non-sample holes in each unit area of four adjacent sample wells, by which the unit area is defined, can be configured to provide the same thermal conductive effect to the four adjacent sample wells. This configuration can improve the thermal uniformity among the sample wells of the thermal block.

[28] In addition, in a case in which each of the sample wells is physically connected in a straight line to the surrounding sample wells, including the sample wells located on diagonal lines passing therethrough, the connecting portions between the sample wells can serve as support walls, so that the durability of the entire thermal block can be increased.

[29]

Brief Description of Drawings

[30] FIG. 1 is a perspective view illustrating a thermal block according to the present disclosure;

[31] FIG. 2 is a plan view of the thermal block according to the present disclosure;

[32] FIG. 3 is a schematic view illustrating the array of the sample wells and the non-sample holes provided in the thermal block according to the present disclosure;

[33] FIG. 4 is a schematic view illustrating the array of the non-sample holes provided in the thermal block according to the present disclosure, in which the non-sample holes in the unit area, defined by four adjacent sample wells, are arranged to provide the same thermal conductive effect to the four adjacent sample wells;

[34] FIG. 5 is a cross-sectional view illustrating cross-sections of a sample well and a non-sample hole, taken along line A-B in FIG. 2;

[35] FIG. 6 is a cross-sectional view illustrating the thermal block according to the present disclosure, taken along line C-D in FIG. 2, passing through the central points of the sample wells arranged side by side in the longitudinal direction of the thermal block, in which none of the non-sample holes are provided;

[36] FIG. 7 is a cross-sectional view illustrating the thermal block according to the present disclosure, taking along line E-F in FIG. 2, passing through the central points of the sample wells arranged in a diagonal direction, in which none of the non-sample holes are provided; and

[37] FIG. 8 is a graph comparing ramp rates of the thermal block according to the present disclosure and the thermal block without non-sample holes of the control group.

[38]

Mode for the Invention

[39] Hereinafter, the present disclosure will be described in detail with reference to the accompanying drawings.

[40] In designating elements of the drawings by reference numerals, the same elements will be designated by the same reference numerals although they are shown in different drawings. Further, in the following description of the present disclosure, a detailed description of known functions and configurations incorporated herein will be omitted in the situation in which the subject matter of the present disclosure may be rendered rather unclear thereby.

[41] In addition, terms, such as first, second, A, B, (a), (b) or the like may be used herein when describing components of the present disclosure. Each of these terminologies is not used to define an essence, order or sequence of a corresponding component but used merely to distinguish the corresponding component from other component(s). In the case that it is described that a certain structural element "is connected to", "is coupled to", or "is in contact with" another structural element, it should be interpreted that another structural element may "be connected to", "be coupled to", or "be in contact with" the structural elements as well as that the certain structural element is directly connected to or is in direct contact with another structural element.

[42]

[43] Hereinafter, embodiments of the present disclosure will be described in detail with reference to the accompanying illustrative drawings so that a person having ordinary skill in the art to which the present disclosure relates could easily put the present disclosure into practice.

[44] FIG. 1 is a perspective view illustrating a thermal block according to an embodiment of the present disclosure, FIG. 2 is a plan view of the thermal block according to the embodiment of the present disclosure, and FIG. 6 is a cross-sectional view of the thermal block according to the embodiment of the present disclosure.

[45] Referring to FIGS. 1 and 6, a thermal block 100 according to the present disclosure includes a top surface 101 and a bottom surface 102 respectively having a length and a width. The top surface 101 and the bottom surface 102 are parallel to each other. The thermal block 100 according to the present disclosure may have a hexahedral shape having a predetermined height (or thickness), more particularly, a rectangular hexahedral shape. The length and width of the top surface may be different from those of the bottom surface. Front, rear, and side surfaces may be bent, depending on the

shape of sample wells or non-sample holes or both.

- [46] In the thermal block 100 according to the present disclosure, a plurality of wells provided therein may be used as reaction vessels, or containers of a reaction vessel, in which samples to be reacted are directly contained, or may be used as receptacles accommodating reaction vessels, or containers of a reaction vessel, fitting thereto respectively. According to an embodiment of the present disclosure, the thermal block 100 may be fabricated using a material having superior thermal conductivity or the like. The thermal block 100 may be made of a metal or a metal alloy (e.g. iron (Fe), copper (Cu), aluminum (Al), gold (Au), silver (Ag), or alloys thereof). The thermal block may be provided by machining a single solid metal piece or by connecting a plurality of metal pieces.
- [47] The thermal block 100 according to the present disclosure is a thermal block allowing a plurality of reactions to be performed therein. Each of the reactions means a chemical, biochemical, or biological transformation in which at least one chemical or biological matter (e.g. a solution, a solvent, or an enzyme) is involved. In the present disclosure, the reaction may be a reaction started, stopped, promoted, or inhibited by a thermal change of a reaction system. For example, the reaction may involve degradation or binding of a biological or chemical matter depending on changes in temperature, or promote or inhibit the activity of enzymes, producing or degrading a chemical or biological matter depending on changes in temperature.
- [48] Specifically, the reaction may mean an amplification reaction. The amplification reaction may be a reaction of increasing a target analyte (e.g. nucleic acid molecules) itself, or a reaction of increasing or decreasing a signal generated in dependence of the presence of the target analyte. The reaction of increasing or decreasing a signal generated in dependence of the presence of the target analyte may or may not be accompanied with an increase in the target analyte. Specifically, the target analyte may be nucleic acid molecules, and the reaction may be a polymerase chain reaction (PCR) or a real-time PCR.
- [49] According to an embodiment of the present disclosure, the thickness of the thermal block 100 according to the present disclosure may range from 5mm to 20mm. If the thickness of the thermal block 100 is less than 5mm, sample wells 103 provided in the thermal block 100 may not be sufficient to accommodate reaction vessels. If the thickness of the thermal block 100 exceeds 20mm, an excessive amount of thermal energy may be inefficiently required to change the temperature of the thermal block 100.
- [50] The length and width of the thermal block 100 may differ depending on the size and number of the sample wells 103 formed in the thermal block 100. The length and width of the thermal block 100 may independently be 10mm or more, 20mm or more, or

30mm or more. Alternatively, the length and width of the thermal block 100 may independently be, but are not limited to, 1,000mm or less, 900mm or less, 800mm or less, 700mm or less, 600mm or less, 500mm or less, 400mm or less, 300mm or less, or 200mm or less.

- [51] The thermal block 100 may include a recess in which a temperature sensor can be fitted. The recess in which the temperature sensor can be fitted may be provided in the top surface, the bottom surface, or a side surface, in particular, in the bottom surface. The shape of the recess may vary depending on the shape of the temperature sensor. For example, the recess may be configured such that a stylus-shaped temperature probe or a button-type temperature probe may be fitted therein. According to an embodiment of the present disclosure, the thermal block of the present disclosure may have a rod-shaped recess in the bottom such that a stylus-shaped temperature probe can be fitted therein. In addition, the thermal block 100 may further include a path along which at least one of a device for supplying optical or electrical energy to reaction vessels or a device able to detect an optical or electrical signal emitted from the reaction vessels can contact the reaction vessels accommodated in the sample wells 103. For example, the thermal block 100 may further include a receptacle in the bottom or a side portion of the sample wells 130, in which a light source or a light detector is accommodated in the receptacle. The receptacle may directly accommodate a light source, such as a light-emitting diode (LED), or a light detector, such as a photodiode, or may accommodate an optical fiber connected to a light source or a light detector.
- [52] According to an embodiment of the present disclosure, the bottom surface 102 of the thermal block 100 may be provided as a planar surface allowing a thermoelectric element, such as a Peltier element, to be in contact therewith.
- [53] The thermoelectric element can serve as a heating element to supply heat, as well as a cooling element to absorb heat, when electrical energy is provided thereto. In response to the heating and cooling of the thermoelectric device, the thermal block can transfer heat to and absorb heat from the reaction vessels accommodated in the sample wells.
- [54] The thermal block according to the present disclosure has the plurality of sample wells 103 provided in the top surface 101 thereof so as to be upwardly open. The sample wells 103 according to the present disclosure are provided in the top surface 101 of the thermal block to directly accommodate samples or accommodate reaction vessels fitting thereto. The sizes and shapes of the sample wells 103 are determined such that the sample wells 103 can be in thermal-conductive contact with the reaction vessels.
- [55] The thermal block 100 according to the present disclosure is configured such that a plurality of reactions can be simultaneously performed therein. The sample wells 103

provided in the thermal block 100 are a plurality of sample wells. The thermal block 100 may include, for example, 4, 6, 8, 12, 16, 24, 32, 40, 48, or more sample wells 103. The thermal block 100 may include, for example, 96, 192, 288, 384, or less sample wells 103. According to an embodiment of the present disclosure, the thermal block 100 may include 4 to 384 upwardly-open sample wells 103.

[56] The plurality of sample wells 103 may be regularly arranged.

[57] The regular array means that the orientations and distances of a single sample well 130 with respect to the adjacent sample wells 103, among the plurality of sample wells 103, are determined by specific regulations. The array of the plurality of sample wells 103 is determined by the regulations.

[58] For example, the plurality of sample wells 103 may be arranged in two or more parallel rows extending in a first direction on the top surface 101. The sample wells 10, arranged in each row, among the plurality of sample wells 103, may be spaced apart from each other at equal distances.

[59] According to an embodiment of the present disclosure, the regular array may be a rectangular array. The rectangular array means an array of the plurality of sample wells 103 that are arranged in two or more parallel rows extending in the first direction while being arranged in two or more columns parallel in a second direction perpendicular to the first direction. Sample wells 103 arranged in each of the columns in the second direction, among the plurality of sample wells 103, are arranged at equal distances.

[60] According to an embodiment of the present disclosure, the regular array may be a square array. The square array is a specific form of the rectangular array in which the distances between the sample wells 103 arranged in the first direction and the distances between the sample wells 103 arranged in the second direction are the same. In a case in which the plurality of sample wells 103 are arranged in the square array, the distances between the sample wells 103, arranged in rows and columns, are the same, and thus, a reaction vessel including a plurality of containers (e.g. a strip of 8-PCR tubes including eight containers connected in line) can be fitted in the thermal block 100 independently of the orientation thereof.

[61] According to an embodiment of the present disclosure, the thermal block 100 according to the present disclosure may include, but is not limited to, 96 sample wells 103 arranged in the form of a matrix comprised of 12 columns and 8 rows, 16 sample wells 103 arranged in the form of a matrix comprised of 4 columns and 4 rows, or 384 sample wells 103 arranged in the form of a matrix comprised of 24 columns and 16 rows.

[62] According to an embodiment of the present disclosure, the sample wells 103 according to the present disclosure may be configured to accommodate a reaction vessel therein. The reaction vessel may be a reaction tube including a single container,

or may be a reaction strip or reaction plate including a plurality of containers. The reaction strip refers to a reaction vessel comprised of a plurality of containers arranged in a row at equal distances, while the reaction plate refers to a reaction vessel comprised of a plurality of containers arranged in two or more rows at equal distances. The container refers to a unit able to accommodate a reactant (e.g. a reaction solution or reaction mixture). The reaction vessel may be referred to as a test tube, a PCR tube, a strip tube, a multi-well PCR plate, etc., depending on the use and shape thereof.

- [63] The sample wells 103 according to the present disclosure may vary depending on the shape of the containers of the reaction vessels fitted therein. For example, the sample wells 103 according to the present disclosure may be configured to accommodate typical conical tubes in use for nucleic acid amplification. In this case, each of the sample wells 103 may be tapered such that an open area thereof, opened through the top surface 101, is circular, and the diameter of the floor 105 thereof is smaller than the diameter of the opening 104, opened upwardly. FIG. 5 illustrates an example cross-section of the sample well. As illustrated in FIG. 5, each sample well 103 may be tapered such that an outer surface of a reaction vessel is in close contact with an inner wall (or inner surface) of the sample well.
- [64] According to an embodiment of the present disclosure, the sample wells 103 may be configured to accommodate reaction vessels respectively having a container having a volume in which a nucleic acid amplification reaction solution of, for example, 10 μl or more, 20 μl or more, 30 μl or more, or 40 μl or more can be contained.
- [65] According to an embodiment of the present disclosure, the sample wells 103 may be configured to accommodate reaction vessels respectively having a container having a volume in which a nucleic acid amplification reaction solution of, for example, 700 μl or less, 600 μl or less, 500 μl or less, 400 μl or less, 300 μl or less, 200 μl or less, 100 μl or less, or 50 μl or less can be contained.
- [66] The thermal block 100 includes two or more non-sample holes 106. The non-sample holes 106 are provided in the top surface 101 of the thermal block so as to be open through the top surface 101. The non-sample holes 106 may be different from the sample wells 103, and no reaction vessels may be accommodated in the non-sample holes 106. The non-sample holes 106 are provided to reduce energy for changing the temperature of the sample wells 103.
- [67] Although the shape of the non-sample holes 106 is not specifically limited, the non-sample holes 106 may be configured such that reaction vessels fitting to the sample wells 103 are not accommodated therein. The reaction vessels fitting to the sample wells 103 refer to reaction vessels configured such that the outer surface of each of the reaction vessels is in close contact with the inner wall of the corresponding sample well 103 when the reaction vessels are fitted into the sample wells 130. The shape of

the non-sample holes 106 may include, but is not limited to, a circle, an ellipse, or a polygon, such as a quadrangle or a triangle. According to an embodiment of the present disclosure, the non-sample holes 106 may have a cylindrical structure, with the top surface thereof being circular or elliptical.

[68] The size of an opening 107 of each of the non-sample holes, provided in the top surface of the thermal block 100, is smaller than the size of the opening 104 of each of the sample wells. Since the size of the opening 107 of each of the non-sample holes is smaller than the size of the opening 104 of each of the sample wells, a risk that a user may erroneously fit a reaction vessel, to be fitted into a sample well 103, into a non-sample hole 106 can be prevented. In a case in which a configuration preventing erroneous-fitting is provided in a central portion of the thermal block as in the case of United States Patent No 8,367,014, it is possible to prevent a reaction vessel covering the entire area of the thermal block, such as the plate including 96 sample wells, from being erroneously fitted to the thermal block. However, it is impossible to prevent a reaction vessel, such as a single PCR tube or a strip of 8-PCR tubes, from being erroneously fitted. In contrast, in the thermal block 100 according to the present disclosure, the size of the opening 107 of the non-sample hole is smaller than the size of the opening 104 of the sample well. This can prevent reaction vessels from being erroneously fitted into the thermal block, irrespective of the type of reaction vessels or the position in which reaction vessels are fitted.

[69] According to an embodiment of the present disclosure, the non-sample holes may have different sizes of openings. It is not necessary for the non-sample holes according to the present disclosure to have the same shape and size. For example, smaller non-sample holes may be additionally provided in spaces between the non-sample holes provided in unit areas.

[70] The non-sample holes 106, provided in the thermal block 100, may have the same pattern. The non-sample holes 106 having the same pattern means that, when a plurality of diagrams having the same shape and area are drawn by connecting the central points of the sample wells 103 in the thermal block 100, the number and distribution type of the non-sample holes 106 are the same in the plurality of diagrams having the same shape and area.

[71] Specifically, the non-sample holes 106 are configured to have the same pattern in the unit areas 130 respectively defined by connecting the central points of four adjacent sample wells 130 in the thermal block 100.

[72] The four adjacent sample wells 103a to 103d are a combination of four sample wells, located mostly adjacently to each other, among the sample wells provided in the top surface 101 of the thermal block. Referring to FIGS. 3 and 4, the combination of four most adjacent sample wells may be determined by determining one sample well 103a

and another sample well 103b located most adjacently to the sample well 103a, and then determining two sample wells 103c and 103d located most adjacently to the sample wells 103a and 103b while not being placed side by side to the sample wells 103a and 103b. The sample wells 103c and 103d not being placed side by side to the sample wells 103a and 103b means that the sample wells 103c and 103d are not located on a line connecting the central points of the sample wells 103a and 103b.

[73] According to an embodiment of the present disclosure, the four adjacent sample wells 103a to 103d may be a combination of four sample wells located most adjacently to each other while being arranged such that a quadrangle (e.g. a rectangle or square) may be formed by connecting the central points thereof.

[74] The unit areas 130 are areas defined to illustrate the patterns of the sample wells 103 and the non-sample holes 106 of the thermal block 100 according to the present disclosure. Each of the unit areas 130 is an area defined by connecting the central points of the four adjacent sample wells 103a to 103d.

[75] A portion of the unit area, except for spaces occupied by the sample wells, is defined as a mass region. The spaces occupied by the four adjacent sample wells are not included in the mass region. Thus, the mass region is a region in which no reaction vessels are located. Accordingly, the smaller the mass of the mass region, the smaller the amount of thermal energy change necessary to change the temperature of reactants within the reaction vessels to an intended temperature may be.

[76] As illustrated in FIG. 3, according to an embodiment of the present disclosure, the mass region may be a portion of the unit area defined by connecting the central points of the four adjacent sample wells 103a to 103d, except for portions in which the sample wells are provided. According to an embodiment of the present disclosure, the mass region may be a portion of the unit area defined by connecting the central points of the four adjacent sample wells 103a to 103d, except for portions occupied by the sample wells.

[77] The non-sample holes 106 of the thermal block 100 may be provided in the mass regions. The provision of the non-sample holes 106 can reduce the mass of the mass region, so that the amount of thermal energy change necessary to change the temperature of reactants within the reaction vessels to an intended temperature can be reduced.

[78] According to an embodiment of the present disclosure, the non-sample holes 106, provided in the unit areas 130, may have the same patterns. This means that the non-sample holes 106, provided in the plurality of unit areas 130 respectively defined by four adjacent sample wells, of the thermal block 100, are configured such that the distributions (relative positions), sizes, and shapes thereof are the same. Dotted areas in FIG. 2 randomly illustrate unit areas 130 that can be set in the thermal block according

to the present disclosure. As illustrated in FIG. 2, the non-sample holes 106 provided in all of the unit areas 130, respectively defined by four adjacent sample wells, in the thermal block 100 according to the present disclosure, have the same patterns.

[79] Since the plurality of sample wells 103 are regularly arranged in the thermal block 100 according to the present disclosure, all of the unit areas 130 in the thermal block 100 have the same shapes and areas. Therefore, in a case in which the non-sample holes 106 in the unit areas 130 are provided in the same patterns, the non-sample holes 106 can provide the same thermal conductive effect to all of the sample wells 103. This can minimize differences in temperature among the sample wells that would otherwise occur due to rapid heating and cooling of the thermal block. Although the unit areas 130 are generally set such that each of the entire non-sample holes 106 of the thermal block is included in one of the unit areas 130, which can be defined in the thermal block, some of the non-sample holes 106 may not be included in the unit areas 130, depending on the setting of the unit areas 130. Such non-sample holes 106 may be arranged in consideration of the arrangement of the patterns of the entire non-sample holes 106 of the thermal block.

[80] According to an embodiment of the present disclosure, a single non-sample hole 106 may be provided in a single unit area 130. In other words, each of the entire non-sample holes 106 may be provided in the corresponding unit area 130, with none of the non-sample holes 106 extending over two or more unit areas 130. In a case in which the non-sample holes 106 are provided in this manner, none of the portions connecting the sample wells 103 are disconnected by the non-sample holes 106, and thus, the durability of the thermal block 100 can be improved. In addition, alternatively, according to an embodiment of the present disclosure, a single non-sample hole 106 may extend over two or more adjacent unit areas 130. In a case in which the non-sample holes 106 in the unit areas 130 have the same patterns, a single non-sample hole 106 may extend over two or more adjacent unit areas 130.

[81] According to an embodiment of the present disclosure, each of the unit areas 130 may be a minimal quadrangular (e.g. rectangular or square) area defined by connecting four adjacent sample wells in the thermal block 100, and the non-sample holes 106 may be provided such that the non-sample holes 106 in the minimal quadrangular areas have the same patterns.

[82] The minimal quadrangle refers to a quadrangle, the area of which is a minimal area, and in which a total of the lengths of four sides of the rectangle are minimal, among the quadrangles definable by selecting four sample wells 103a to 103d from among the plurality of sample wells 103 provided in the top surface 101 of the thermal block, which are arranged such that a quadrangle can be defined by connecting the central points thereof.

- [83] In addition, the non-sample holes 106 are configured such that the opening 107 of each of the non-sample holes is smaller than the opening 104 of each of the sample wells. Thus, the thermal block 100 may be provided with more non-sample holes 106 than the sample wells 103 in order to reduce the mass of the thermal block 100.
- [84] According to an embodiment of the present disclosure, two or more non-sample holes 106 are included in each of the unit areas 130, respectively defined by connecting the central points of four adjacent sample wells in the thermal block 100.
- [85] According to an embodiment of the present disclosure, the number of the non-sample holes 106 provided in the unit areas 130, respectively defined by connecting the central points of four adjacent sample wells in the thermal block 100, may be a multiple of 2. In a case in which the number of the non-sample holes 106 provided in the unit areas 130 is a multiple of 2, the non-sample holes 106 in each unit area 130 may be provided the same or symmetrical with respect to the central point of each of the four sample wells by which the unit area 130 is defined. The number of the non-sample holes 106, provided in each of the unit areas 130, may be a multiple of 4.
- [86] According to an embodiment of the present disclosure, four or more non-sample holes 106 may be provided in the unit areas 130 defined by connecting the central points of four adjacent sample wells in the thermal block 100. Specifically, the number of the non-sample holes 106 provided in the unit areas 130 may be, but is not limited to, 4 to 100, 4 to 48, 4 to 24, or 4 to 16. According to an embodiment of the present disclosure, the number of the non-sample holes 106 included in the unit areas may be, but is not limited to, 2, 4, 6, 8, 10, 12, 14, or 16.
- [87] According to an embodiment of the present disclosure, the non-sample holes 106 may be provided such that the non-sample holes 106 in the unit area 130 provide the same thermal conductive effect to the four adjacent sample wells.
- [88] In a case in which the non-sample holes 106 are provided in the unit area 130 to provide the same thermal conductive effect to the four adjacent sample wells, by which the unit area 130 is defined, the sample wells 103, provided within the thermal block 100, receive the same thermal conductive effect from the surrounding non-sample holes 106. This can help thermal uniformity to be maintained among the sample wells. The non-sample holes 106 being provided in the unit area 130 so as to provide the same thermal conductive effect to the respective four adjacent sample wells may mean that, for example, the non-sample holes 106 in the unit area, defined by connecting the central points of four adjacent sample wells, in the thermal block, may be the same as or symmetrical with respect to the central point of each of the sample wells.
- [89] According to an embodiment of the present disclosure, the non-sample holes 106 in each unit area 130 may be provided to be the same or symmetrical with respect to the central point of each of the four sample wells by which the unit area 130 is defined.

This may indicate that the four adjacent sample wells have the same positional relationships with respect to the non-sample holes in the corresponding unit area 130. In addition, a figure drawn by connecting one sample well among the four sample wells and the non-sample holes in the unit area 130 may be the same as or symmetrical with respect to a figure drawn by connecting another sample well among the four sample wells and the non-sample holes in the unit area 130.

[90] In other words, the non-sample holes 106 provided in each of the unit areas 130 may be arranged in the same or symmetrical patterns, with respect to the four sample wells by which the unit area 130 is defined. FIG. 3 illustrates four adjacent sample wells 103 (103a to 103d) in the thermal block, as well as a unit area 130 defined by the four adjacent sample wells 103a to 103d and non-sample holes 106 provided in the unit area 130. FIG. 4 illustrates figures respectively drawn by connecting each of the four sample wells 103a to 103d and all of the non-sample holes 106 in the unit area 130 defined by connecting the central points of four adjacent sample wells. As illustrated in FIG. 4, a figure drawn by connecting one sample well among the four sample wells 103a to 103d and two or more non-sample holes 106 in the unit area 130 may be the same as, or be mirror-symmetrical with respect to, while having the same size as, a figure drawn by connecting another sample well among the four sample wells 103a to 103d and the two or more non-sample holes 106 in the unit area 130.

[91] In a case in which the non-sample holes 106, included in each of the unit areas 130, are provided in the same patterns or in patterns symmetrical with respect to each of the four sample wells by which the unit area 130 is defined, a group of the non-sample holes in the unit area 130 can provide the same thermal effect to the sample wells. Accordingly, the thermal block of the present disclosure can maintain thermal uniformity among the sample wells.

[92] As described above, the regular array of the plurality of sample wells 103 may be a rectangular array.

[93] According to an embodiment of the present disclosure, a regular array of the plurality of sample wells 103 may be a rectangular array, and none of diagonal lines of each unit area 130 may contact or intersect at least one non-sample hole among the non-sample holes 106 in the unit area 130. The term "contacting" used herein means that a single straight line contacts a point of a single non-sample hole, in which the contact point may be referred to as a tangent point. The term "intersecting" used herein means that a single straight line contacts two points of a single non-sample holes, in which the contact points may be referred to as intersections or points of intersection. The diagonal lines of each unit area 130 are defined by connecting diagonally the central points of four adjacent sample wells by which the each unit area is defined.

[94] According to an embodiment of the present disclosure, the regular array of the

plurality of sample wells 103 may be a rectangular array, and none of diagonal lines of each unit area 130 may contact or intersect any of the non-sample holes 106 in the unit area 130. In other words, the non-sample holes 106 in each unit area 130, defined by connecting the central points of four adjacent sample wells, may be configured such that none of diagonal lines of the unit area 130 are included in the non-sample holes 106. The non-sample holes 106, provided in the thermal block 100 according to the present disclosure, may be configured such that none of the diagonal lines of each unit area 130, defined by connecting the sample wells 103, contact or intersect the non-sample holes 106. Accordingly, in this case, as illustrated in FIG. 7, none of the non-sample holes 106 appear in the cross-section of the thermal block 100 according to the present disclosure, taken along a diagonal line (i.e. taken along line E-F in FIG. 2).

[95] In a case in which none of the non-sample holes 103 contact or intersect the diagonal lines connecting the sample wells 103 as described above, each of the sample wells 103 in the thermal block 100 is physically connected to sample wells, diagonally adjacent thereto, among the remaining sample wells, along straight lines.

[96] In a conventional sample block or thermal block, a mass reduction hole having a significant size is provided in a central portion of a mass region of each of the unit areas 130. In the thermal block having this configuration, each of the sample wells is not physically connected to diagonally-adjacent sample wells along straight lines while being physically connected to four adjacent sample wells along straight lines. According to another configuration known in the art, inverted conical sample wells are only connected via a bottom backing, and all of the top portions of the sample wells are independently disconnected from each other. In addition, in a case in which the inverted conical sample wells are independently provided as in the latter case, the sample wells are physically disconnected from adjacent sample wells, except for the bottom backing. Accordingly, the sample wells provided in such a configuration have lower physical durability, which is problematic.

[97] In contrast, in the thermal block 100 according to the present disclosure, each of sample wells 103 is physically connected to eight (8) surrounding sample wells along straight lines. Accordingly, the thermal block 100 according to the present disclosure can reduce the amount of thermal energy change necessary to change the temperature of a reactant within a reaction vessel to an intended temperature by reducing the mass of the mass region, and can provide superior durability over the conventional thermal block.

[98] According to an embodiment of the present disclosure, the thermal block 100 according to the present disclosure may be configured such that none of the entire straight lines connecting the central points of the four adjacent sample wells, by which the unit area 130 is defined, may contact or intersect the non-sample holes 106 in the

unit area 130. In other words, none of the non-sample holes 106 may be provided on any of straight lines connecting the central points of the four sample wells by which the unit area 130 is defined. As illustrated in FIGS. 6 and 7, the thermal block 100 according to the present disclosure may be configured such that none of the non-sample holes 106 appear in the cross-sections taken along lines (e.g. lines C-D and E-F in FIG. 2) connecting the central points of the sample wells 103. The entirety of straight lines connecting the central points of the four sample wells include four sides and two diagonal lines of the quadrangle defined by connecting the central points of the four sample wells.

[99]

[100] Hereinafter, embodiments of the present disclosure will be described in more detail. The following embodiments shall be interpreted as being illustrative for a better understanding of the present disclosure. It will be apparent to a person having ordinary skill in the art that the scope of the present disclosure is not limited to the following embodiments.

[101]

[102] **Example 1: Fabrication of Thermal Block**

[103] The thermal block according to the present disclosure can be freely fabricated such that wells thereof conform to mXn standards. The thermal blocks according to the present example were fabricated to have 96 wells (12X8) and 16 wells (4X4) by way of example. The thermal blocks were fabricated by grinding, cutting, and chemically-etching aluminum (Al) blocks, so that a total of four non-sample holes are provided in each unit area, as illustrated in FIG. 2.

[104] A thermal block having the same size was fabricated as a control group, such that only sample wells were provided and no non-sample holes were provided. The masses of the thermal blocks of the control group were measured, so as to investigate the efficiency of mass reduction due to the fabrication of non-sample holes.

[105] As a result, as represented in Table 1, a 96-well thermal block of the control group, including only the sample wells without the non-sample holes, was measured to be 180g, while the 96-well thermal block according to the present example was measured to be 90g.

[106] Accordingly, it will be appreciated that the mass of the thermal block according to the present example was reduced by 50%, as compared to the thermal block of the control group. Such a reduction in mass can reduce the thermal capacity of the thermal block according to the present example, thereby advantageously realizing a rapid ramp rate.

[107]

[108] [Table 1]

Item	Thermal Block of Example	Thermal Block of Control Group (No Non-sample holes)
Weight of Thermal Block (96 well)	90 g	180 g

[109]

[110] **Example 2: Measurement of Thermal Uniformity**

[111] Thermal uniformity was investigated by simultaneously measuring temperatures at a plurality of points of the thermal block and determining differences between the temperatures.

[112] T-checkers for measuring temperatures were uniformly provided in uppermost, lower most, and middle rows of the thermal block. The temperatures were measured by raising the temperature of the thermal block from 27°C to 60°C. At ten seconds after arrival at 60°C, temperatures at respective points were recorded. The difference between the highest temperature and the lowest temperature among the temperatures at the respective points was calculated. The result was obtained by repeating the test by a total of ten times or more.

[113] As a result of the measurement, as represented in Table 2, it will be appreciated that the thermal uniformity of the thermal block according to the present example was $\pm 0.2^\circ\text{C}$. Considering that the thermal uniformity of the thermal block of another conventional PCR device is $\pm 0.4^\circ\text{C}$, it can be appreciated that the thermal block according to the present example has superior thermal uniformity.

[114]

[115] [Table 2]

Item	Thermal Block of Example	Reference
Thermal Accuracy	$\pm 0.2^\circ\text{C}$	$\pm 0.2^\circ\text{C}$
Thermal Block Uniformity	$\pm 0.2^\circ\text{C}$	$\pm 0.4^\circ\text{C}$

[116]

[117] **Example 3: Measurement of Ramp Rate**

[118] A reduction in mass can increase thermal conduction efficiency due to reduced thermal capacity, so that a rate at which the temperature rises or falls can be improved when the same current is supplied. To evaluate such characteristics, the temperature rise rates of a 16-well thermal block having the structure according to the present disclosure and a 16-well thermal block without the mass reduction structure were

compared by supplying the same current thereto.

[119] The test was performed by measuring the time taken to reach certain temperatures. More specifically, the test was performed by measuring (1) periods of time taken to increase the temperature to 60°C from room temperature and (2) periods of time taken to increase the temperature to 95°C from room temperature.

[120] As a result of the measurement, as represented in Table 3 and illustrated in FIG. 8, it can be appreciated that the thermal block having the mass reduction structure according to the present disclosure had improvements in the ramp rate. More specifically, the ramp rate improvement in the experimental group was about 16% when the temperature was raised to 95°C, while being about 34% when the temperature was raised to 60°C. The foregoing test result supports that the temperature growth rate is improved by the mass reduction structure of the thermal block according to the present disclosure.

[121]

[122] [Table 3]

Test Condition	Ramp Rate of Control Group (Block Without Non-sample holes)	Ramp Rate of Thermal Block of Example	Ramp Rate Im- provement
Room Temp. - > 60°C	1.3°C/sec	1.8°C/sec	34%
Room Temp. - > 90°C	1.3°C/sec	1.5°C/sec	16%

[123] The features, structures, configurations, and effects described in the present disclosure are included in at least one embodiment but are not necessarily limited to a particular embodiment. A person skilled in the art can apply the features, structures, configurations, and effects illustrated in the particular embodiment embodiments to another one or more additional embodiment embodiments by combining or modifying such features, structures, configurations, and effects. It should be understood that all such combinations and modifications are included within the scope of the present disclosure. Although the exemplary embodiments have been described for illustrative purposes, a person skilled in the art will appreciate that various modifications and applications are possible without departing from the essential characteristics of the present disclosure. For example, the specific components of the exemplary embodiments may be variously modified. The scope of protection of the present disclosure should be construed based on the following claims, and all technical ideas within the scope of equivalents thereof should be construed as being included within

the scope of the present disclosure.

[124] **CROSS-REFERENCE TO RELATED APPLICATION**

[125] This application claims priority from Korean Patent Application No. 10-2018-0074957, filed on June 28, 2018, which is hereby incorporated by reference for all purposes as if fully set forth herein.

[126] **Description of Reference Numerals of Drawings**

[127] 100: thermal block (sample block)

[128] 101: top surface

[129] 102: bottom surface

[130] 103: sample well

[131] 104: opening of sample well

[132] 105: floor of sample well

[133] 106: non-sample hole

[134] 107: opening of non-sample hole

[135] 103: unit region

Claims

- [Claim 1] A thermal block for performing a plurality of reactions, comprising:
a top surface and a bottom surface having a length and a width and being parallel to each other;
a plurality of sample wells provided in the top surface to be open upwardly, the plurality of sample wells being in a regular array; and
two or more non-sample holes provided in the top surface to be open upwardly, an open area of each of the non-sample holes being smaller than an open area of each of the sample wells,
wherein the two or more non-sample holes are provided in a unit area defined by connecting central points of four adjacent sample wells among the plurality of sample wells in the thermal block.
- [Claim 2] The thermal block according to claim 1, wherein the sample wells are configured to accommodate reaction vessels.
- [Claim 3] The thermal block according to claim 1, wherein the four or more non-sample holes are provided in the unit area defined by connecting the central points of the four adjacent sample wells in the thermal block.
- [Claim 4] The thermal block according to claim 1, wherein the regular array of the plurality of sample wells comprises a rectangular array and none of diagonal lines of the unit area contact or intersect at least one non-sample hole among the two or more non-sample holes in the unit area.
- [Claim 5] The thermal block according to claim 1, wherein the non-sample holes are configured such that the non-sample holes in the unit area provide same thermal conductive effect to the four adjacent sample wells.
- [Claim 6] The thermal block according to claim 4, wherein none of straight lines connecting the central points of the four adjacent sample wells, by which the unit area is defined, contact or intersect the non-sample holes in the unit area.

[Fig. 1]

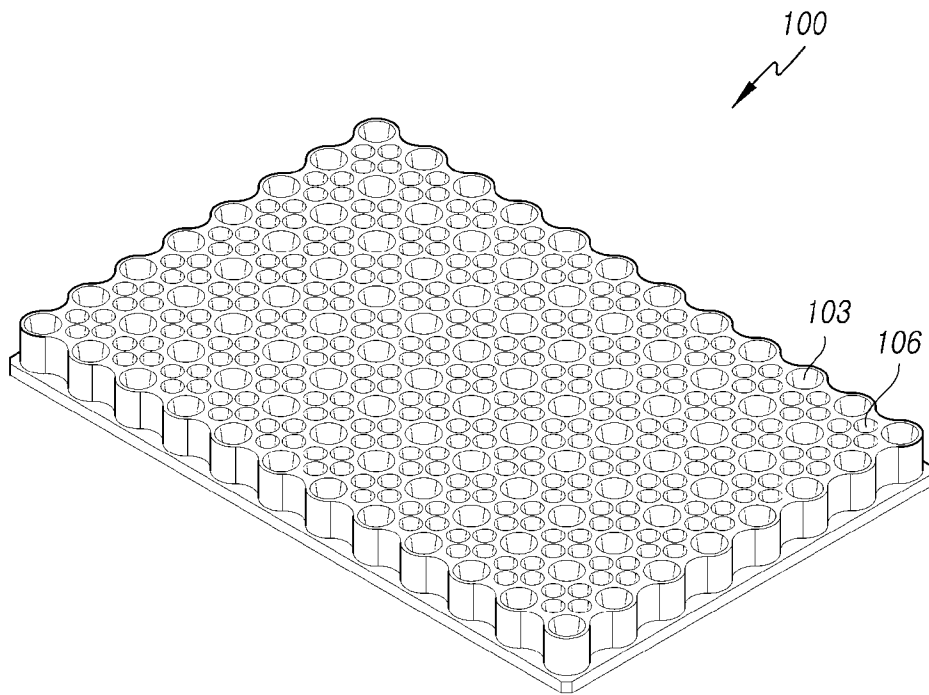

[Fig. 2]

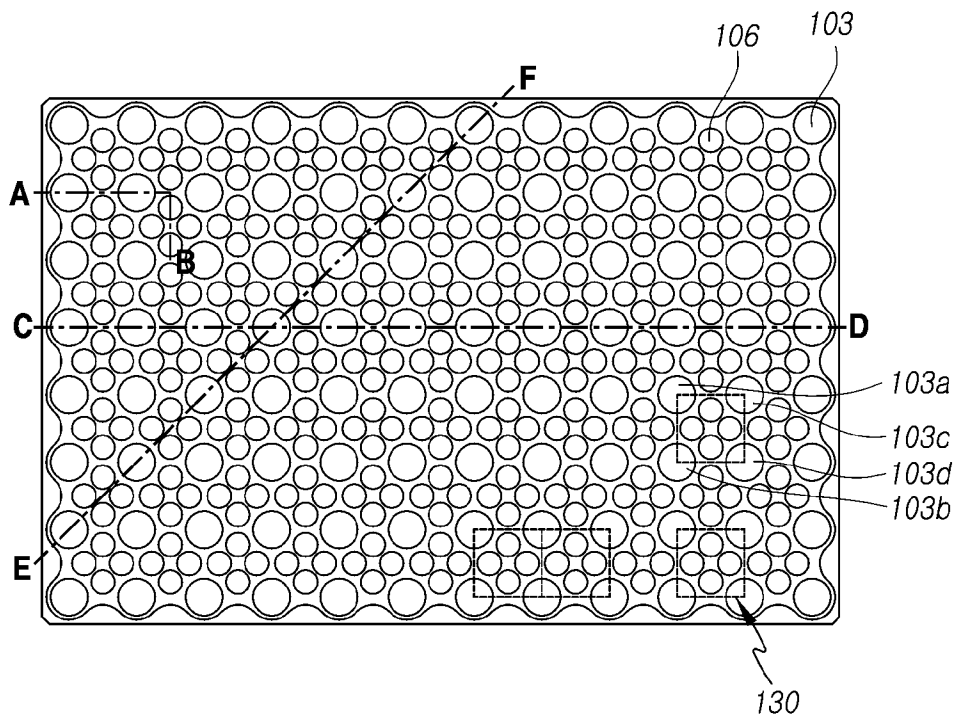

[Fig. 3]

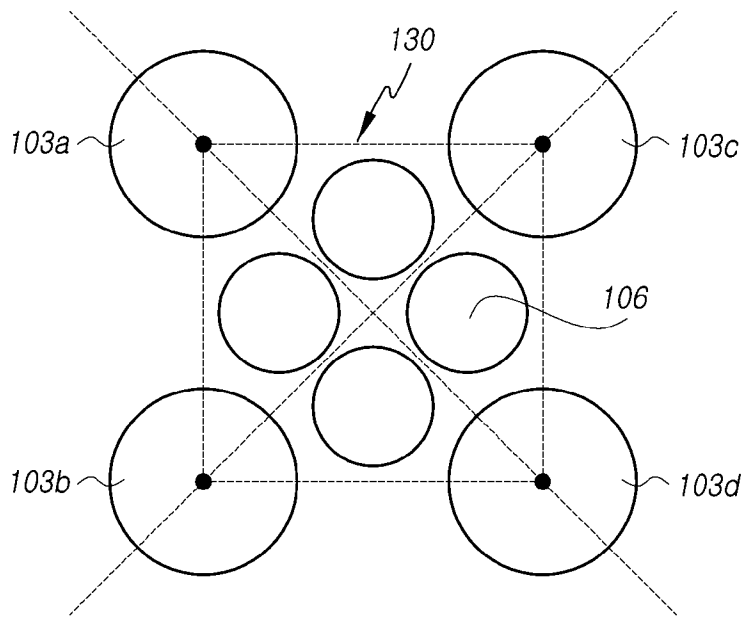

[Fig. 4]

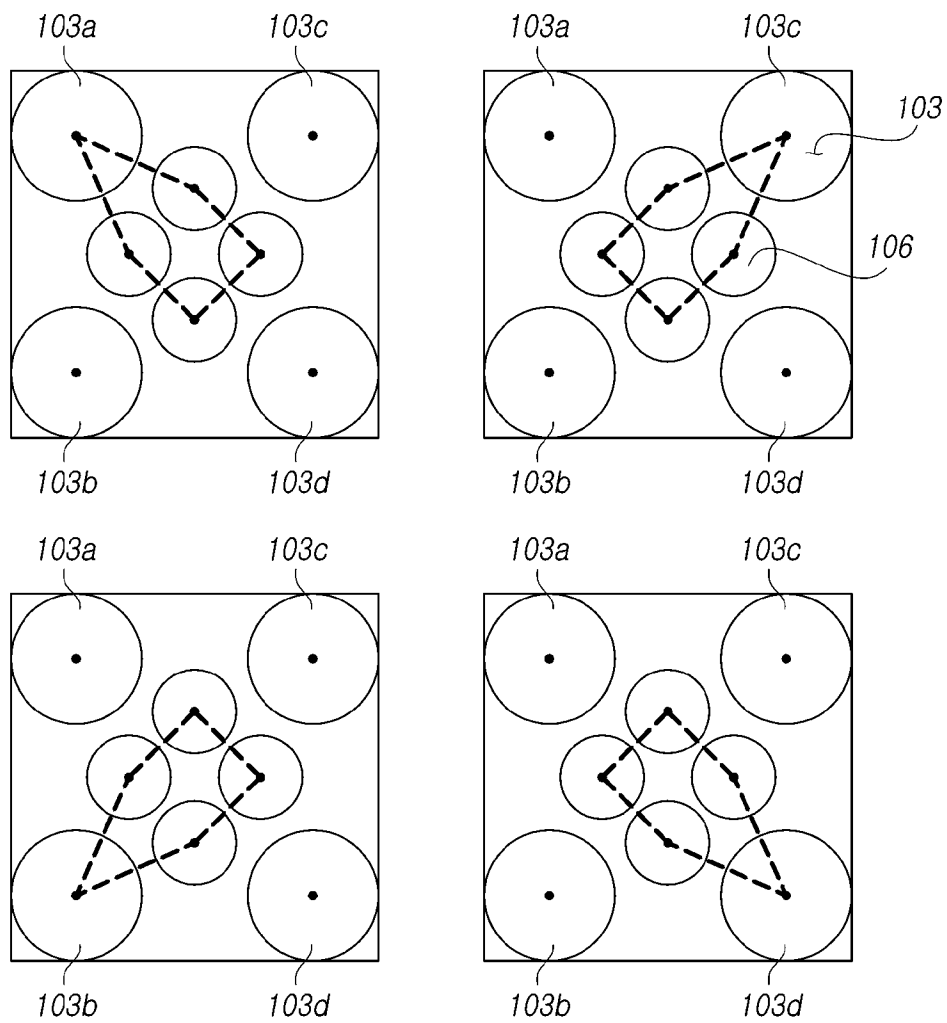

[Fig. 5]

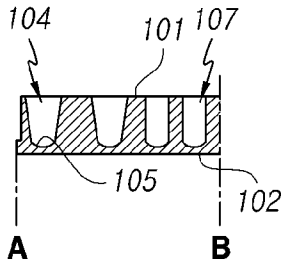

[Fig. 6]

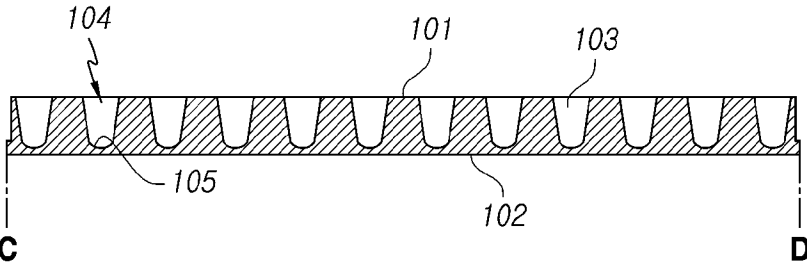

[Fig. 7]

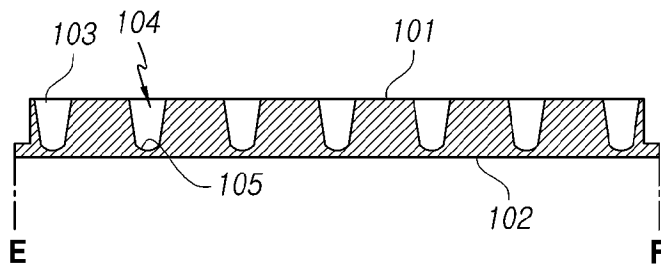

[Fig. 8]

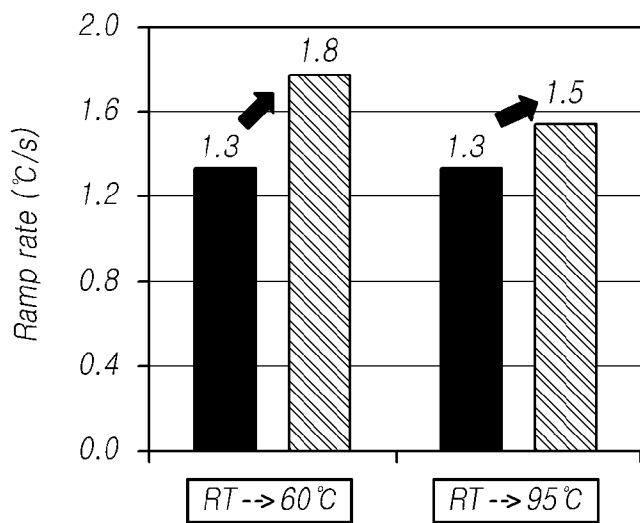

Control thermal block
 Thermal block of the present invention

A. CLASSIFICATION OF SUBJECT MATTER**B01L 7/00(2006.01)i, B01L 3/00(2006.01)i**

According to International Patent Classification (IPC) or to both national classification and IPC

B. FIELDS SEARCHEDMinimum documentation searched (classification system followed by classification symbols)
B01L 7/00; B01L 3/00; C12M 1/00; C12M 1/02; C12M 1/36; C12M 1/38; C12P 19/34Documentation searched other than minimum documentation to the extent that such documents are included in the fields searched
Korean utility models and applications for utility models
Japanese utility models and applications for utility modelsElectronic data base consulted during the international search (name of data base and, where practicable, search terms used)
eKOMPASS(KIPO internal) & Keywords: thermal block, sample wells, non-sample hole, PCR**C. DOCUMENTS CONSIDERED TO BE RELEVANT**

Category*	Citation of document, with indication, where appropriate, of the relevant passages	Relevant to claim No.
X	US 2008-0003650 A1 (BANERJI, SUNAND) 03 January 2008 See paragraphs [0010], [0013], [0034], [0035]; claim 1; and figure 1.	1-6
A	US 2009-0275113 A1 (MALTEZOS, GEORGE et al.) 05 November 2009 See the entire document.	1-6
A	US 2013-0143272 A1 (GUO, KUN et al.) 06 June 2013 See the entire document.	1-6
A	US 2003-0044969 A1 (SHIN, HON SIU et al.) 06 March 2003 See the entire document.	1-6
A	US 2008-0248534 A1 (LIM, CHEE KIONG et al.) 09 October 2008 See the entire document.	1-6

 Further documents are listed in the continuation of Box C. See patent family annex.

* Special categories of cited documents:

"A" document defining the general state of the art which is not considered to be of particular relevance

"D" document cited by the applicant in the international application

"E" earlier application or patent but published on or after the international filing date

"L" document which may throw doubts on priority claim(s) or which is cited to establish the publication date of another citation or other special reason (as specified)

"O" document referring to an oral disclosure, use, exhibition or other means

"P" document published prior to the international filing date but later than the priority date claimed

"T" later document published after the international filing date or priority date and not in conflict with the application but cited to understand the principle or theory underlying the invention

"X" document of particular relevance; the claimed invention cannot be considered novel or cannot be considered to involve an inventive step when the document is taken alone

"Y" document of particular relevance; the claimed invention cannot be considered to involve an inventive step when the document is combined with one or more other such documents, such combination being obvious to a person skilled in the art

"&" document member of the same patent family

Date of the actual completion of the international search

08 October 2019 (08.10.2019)

Date of mailing of the international search report

08 October 2019 (08.10.2019)

Name and mailing address of the ISA/KR

International Application Division

Korean Intellectual Property Office

189 Cheongsa-ro, Seo-gu, Daejeon, 35208, Republic of Korea

Facsimile No. +82-42-481-8578

Authorized officer

MIN, In Gyou

Telephone No. +82-42-481-3326



INTERNATIONAL SEARCH REPORT

Information on patent family members

International application No.

PCT/KR2019/007858

Patent document cited in search report	Publication date	Patent family member(s)	Publication date
US 2008-0003650 A1	03/01/2008	CA 2656688 A1	03/01/2008
		CA 2656688 C	04/12/2012
		CN 101511990 A	19/08/2009
		CN 101511990 B	21/08/2013
		EP 2040841 A2	01/04/2009
		EP 2040841 A4	16/12/2009
		EP 2040841 B1	03/12/2014
		EP 2754497 A2	16/07/2014
		EP 2754497 A3	17/09/2014
		JP 2009-543064 A	03/12/2009
		JP 4863146 B2	25/01/2012
		US 2008-0003149 A1	03/01/2008
		US 2010-0003725 A1	07/01/2010
		US 2010-0055743 A1	04/03/2010
		US 2013-0122552 A1	16/05/2013
		US 2014-0170706 A1	19/06/2014
		US 7632464 B2	15/12/2009
		US 7955573 B2	07/06/2011
		US 8367014 B2	05/02/2013
		US 8557196 B2	15/10/2013
WO 2008-002991 A2	03/01/2008		
WO 2008-002991 A3	24/07/2008		
WO 2008-002991 A9	03/04/2008		
US 2009-0275113 A1	05/11/2009	CN 101522909 A	02/09/2009
		EP 2027251 A2	25/02/2009
		EP 2027251 A4	05/05/2010
		EP 2535427 A2	19/12/2012
		EP 2535427 A3	24/04/2013
		JP 2009-537152 A	29/10/2009
		US 2008-0003649 A1	03/01/2008
		US 2009-0275014 A1	05/11/2009
		US 2012-0171678 A1	05/07/2012
		US 8003370 B2	23/08/2011
		US 8008046 B2	30/08/2011
		US 8232091 B2	31/07/2012
		US 9316586 B2	19/04/2016
		WO 2008-070198 A2	12/06/2008
WO 2008-070198 A3	16/04/2009		
WO 2008-070198 A8	24/12/2008		
US 2013-0143272 A1	06/06/2013	CA 2832759 A1	15/11/2012
		EP 2704835 A1	12/03/2014
		EP 2704835 A4	24/12/2014
		JP 2014-518758 A	07/08/2014
		US 9149809 B2	06/10/2015
WO 2012-154453 A1	15/11/2012		
US 2003-0044969 A1	06/03/2003	AT 268643 T	15/06/2004

INTERNATIONAL SEARCH REPORT

Information on patent family members

International application No.

PCT/KR2019/007858

Patent document cited in search report	Publication date	Patent family member(s)	Publication date
		AU 3661001 A	14/08/2001
		AU 765790 B2	02/10/2003
		CA 2366978 A1	09/08/2001
		CA 2366978 C	27/12/2005
		DE 60103698 T2	30/06/2005
		EP 1165237 A1	02/01/2002
		EP 1165237 B1	09/06/2004
		JP 2003-521716 A	15/07/2003
		US 2004-0033592 A1	19/02/2004
		US 6638761 B2	28/10/2003
		US 6875604 B2	05/04/2005
		US 7169355 B1	30/01/2007
		WO 01-56697 A1	09/08/2001
		WO 01-56697 A9	09/01/2003
US 2008-0248534 A1	09/10/2008	EP 2137319 A1	30/12/2009
		EP 2137319 A4	16/07/2014
		EP 2137319 B1	25/07/2018
		US 2015-0044727 A1	12/02/2015
		US 2016-0256845 A1	08/09/2016
		US 8871470 B2	28/10/2014
		WO 2008-116184 A1	25/09/2008