

J. D. COTTRELL.
Loom.

No. 220,579.

Patented Oct. 14, 1879.

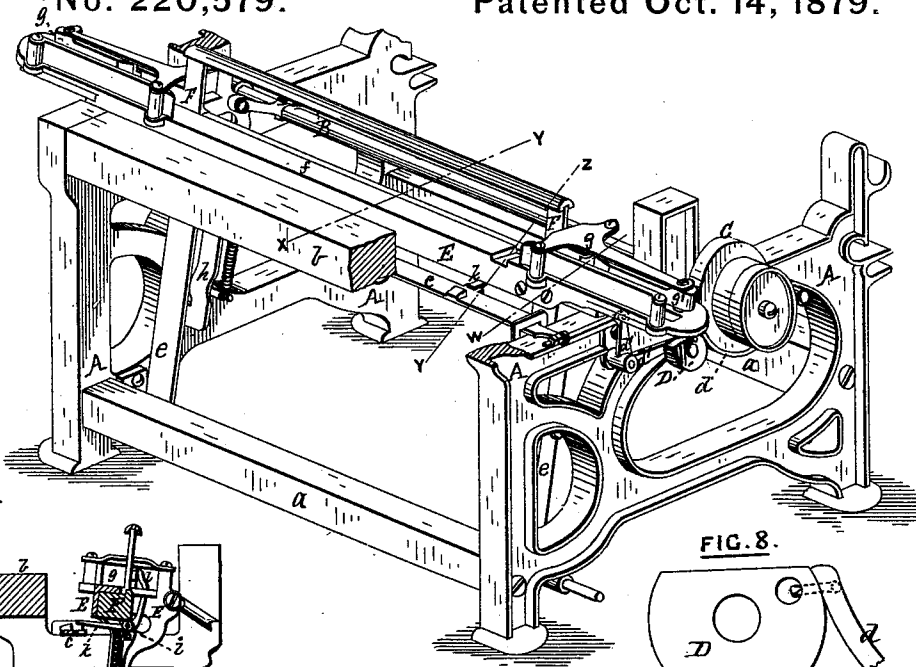

FIG. 1.

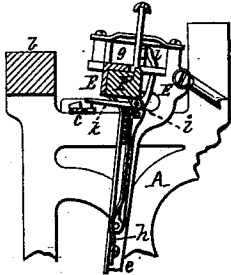

FIG. 3.

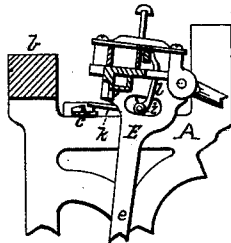

FIG. 4.

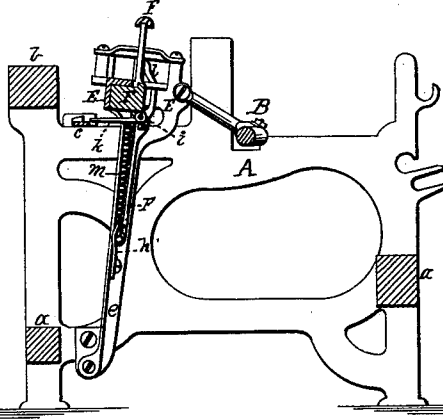

FIG. 2.

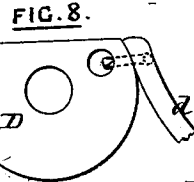

FIG. 8.

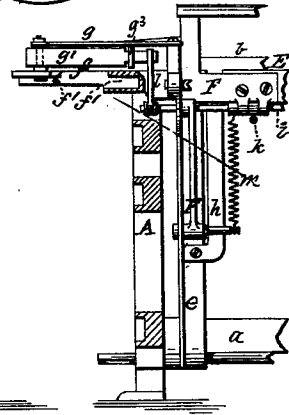

FIG. 5.

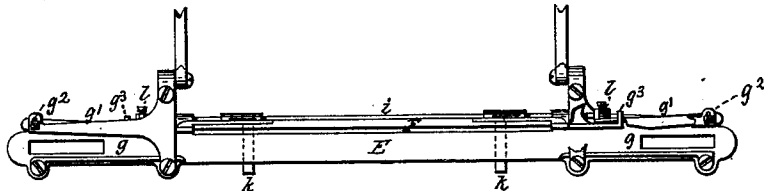

FIG. 6.

ATTEST.

Philip F. Larnet
A. B. Bauldwell

INVENTOR.

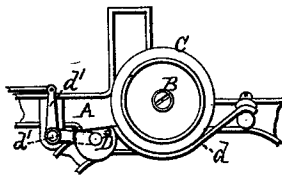

FIG. 7.

Jesse D. Cottrell.
By *Mrs. Wood*
Attorney.

UNITED STATES PATENT OFFICE.

JESSE D. COTTRELL, OF PAWTUCKET, RHODE ISLAND.

IMPROVEMENT IN LOOMS.

Specification forming part of Letters Patent No. **220,579**, dated October 14, 1879; application filed September 17, 1877.

To all whom it may concern:

Be it known that I, JESSE D. COTTRELL, of Pawtucket, in the county of Providence and State of Rhode Island, have invented certain new and useful Improvements in Looms; and I do hereby declare that the following specification, taken in connection with the drawings furnished and forming a part of the same, is a clear, true, and complete description of my said invention.

My said improvements relate to high-speed looms, and embrace certain combinations of mechanism which have been devised with a view to attaining in practical service with my loom a greater number of picks per minute than has heretofore been practically attained with any loom of which I am cognizant. While some of my present improvements are applicable to many kinds of looms, a portion of them are of special value when applied to looms constructed in accordance with certain Letters Patent of the United States issued to me July 4, 1876, No. 179,402. Said loom embodies a novel combination of a spring reed-frame, braking mechanism, and intermediate operative mechanism.

In the loom described in my former Letters Patent referred to, for stopping the loom when a shuttle fails to enter its box I employ, in connection with the daggers which are attached to a rod mounted on the spring reed-frame, a fulcrum rod or shaft, which is attached to the front of the lay, and is provided with two sets of levers, one set of which is in contact with the hinged sides of the shuttle-box, and the other set in contact with the daggers, so that when a shuttle fails to enter its box the daggers will be permitted to abut against the protector-bar and stop the loom.

The object of my present invention is to simplify the construction of this portion of the stopping mechanism; and said feature consists in the combination, with a spring reed-frame and shuttle-boxes having hinged sides, of a dagger-rod attached to the reed-frame, controlled by a spring and provided with levers which are in contact with the hinged sides of the shuttle-box. With the dagger-rod and levers thus constructed I obviate the use of the separate fulcrum-rod for controlling the daggers, and to that extent simplify the mechanism, lessen its cost, and render it more effi-

cient in its operation. Incidental to this improvement I have hinged the rear sides of the shuttle-boxes instead of the front sides, and rely upon the force of powerful springs to enable the reed-frame to perform its beat, instead of employing latch-levers which lock the reed-frame and lay together, as in my former loom; but these changes in themselves considered are not new, and this last-recited feature of my invention is not dependent upon them, although they are deemed desirable by me.

My invention further consists in the combination, with a spring reed-frame and a shuttle-box having one side hinged on a pivot which is laterally adjustable, of a bar on the spring reed-frame which limits the rearward movement of the hinged side or swell of the shuttle-box, whereby the said hinged side or swell may be adjusted with reference to the position of the face line of the reed, its rearward movement limited by the reed-frame, and a thorough frictional contact secured with both sides of the shuttle, for preventing its rebound after having been driven home. The limiting-bar being connected with the spring reed-frame, it permits the swell to freely retire with the reed-frame when the shuttle fails to fully enter its box.

My invention still further consists in a lay-frame which is provided with pockets at the ends of the picker-staff slots for the reception of cushions which relieve the shock of the picker-staff at the termination of each movement. Heretofore strips or pieces of leather for cushions have been let into mortises cut to receive them in such a manner that each end of the leather could be secured by a screw. With my novel pockets a specially-formed cushion of leather, rubber, or other suitable material may be readily inserted, and as readily displaced for renewal if need be. My looms have, preferably, a cast-iron lay-frame, in which the pockets are formed in the casting, but in wooden lays the pockets may be formed by boring or mortising.

I am well aware that rod-pickers have heretofore been cushioned by means of washers of elastic material mounted on the rod and encased within a metallic shell; but such washers can only be inserted or removed by displacing the shell and the rod abutment or collar used therewith. This last-stated feature

of my invention does not relate to the class of sliding or rod pickers, and is only applicable to looms having staff-pickers, and so far as my knowledge extends no cushions therefor have heretofore been used which could be secured in position without screws or other special fastening devices.

To more particularly describe my invention I will refer to the accompanying drawings, in which—

Figure 1 represents, in isometric projection, so much of a loom as is requisite to illustrate my invention, with a portion of the breast-beam and frame broken away for exhibiting the parts. Fig. 2 represents the same in central vertical section on line xy , extending from front to rear of the loom. Fig. 3 represents, in vertical section, the breast-beam and lay on line yz , Fig. 1. Fig. 4 represents, in vertical section, the same on line x , Fig. 1, through one of the shuttle-boxes. Fig. 5 represents, in rear view, one end of the lay, with a portion of the lay-bed broken away to show the cushion-pockets at the ends of the picker-staff slot. Fig. 6 represents the top of the lay, with a portion of the top of one shuttle-box broken away to show the hinged side and the dagger-rod lever. Fig. 7 represents in side view the segmental brake-roller and its lever. Fig. 8 is an enlarged view of brake roller and strap, illustrating one mode of connection.

A denotes the end plates, which, with the cross-bars a and breast-beam b , constitute the frame of the loom, as heretofore. The crank-shaft B , with tight and loose pulleys and friction-pulley or drum C , are also as heretofore. Below the breast-beam b is a laterally-vibrating protector-bar, c , which is connected at its outer end with the shipper and braking mechanism, as heretofore. The brake-strap d , as shown in the drawings, has one end secured to the rounded periphery of the roller closely adjacent to the junction of its straight and curved peripheral lines. It is secured in this instance to the roller by means of a staple, which pierces the strap near its end, and occupies a radial opening or openings formed by cutting into the periphery of the roller, said staple being clinched to the roller within the lateral hole therein. (Clearly shown in the drawings.) The outer end or top of this staple does not project beyond the friction-surface of the strap, and therefore, when the roller is rotated, as in releasing the brake, the end of the strap is passed freely downward and away from the adjacent surface of the friction-drum. E denotes the lay, which is preferably composed of cast-iron, and, as usual, is pivoted at the lower ends of each of its standards e to the frame, or mounted on a rock-shaft. The lay-bed or shuttle-race is shown at f , in which, at each end, is a picker-staff slot provided with my novel pockets, as at f' , as shown in Fig. 5, for the reception of cushions fitted thereto for relieving the shock of the picker-staff in its movements to and fro within the slot. These

pockets permit the ready insertion and removal of the cushions, which may be made of leather or rubber of the proper form and size. The shuttle-boxes g are substantially as have heretofore been made, the rear side thereof, at g^1 , being laterally adjustable on the lay, the pivot thereof being mounted in a lateral slot, as shown at g^2 , Fig. 6. A bar, g^3 , on an extension of the reed-frame, serves as a stop to prevent the hinged side g^1 from being thrown unduly rearward. The bar g^3 is, in this instance, the one side of a metal bow on the end of the reed-frame. The hinged shuttle-box side or swell, at its end is reduced in width, passed through the bow, and therefore is limited in its capacity for movement by the bar and the rear side of the reed-frame.

With the hinged side of the box thus constructed it is possible to effect a desirable adjustment with relation to the shuttle and render it practically impossible for the shuttle to rebound after it has been driven home.

For cushioning the hinged side of the shuttle-box, I sometimes place a spring between it and the bar g^3 .

The reed-frame F is, as heretofore shown in my Letters Patent herein referred to, pivoted to the lay-standards; but instead of being held to the lay-bed by means of bell-crank levers and spiral springs, as shown in said patent, they are directly held by means of strong flat springs h , which are secured at their bases to the standards of the lay-frame, and extend laterally, and thence upward, with a bearing at their upper ends against the rear side of the reed-frame, as clearly shown in Figs. 1 and 5.

At the rear of the reed-frame is the dagger rod or shaft i , mounted in bearings, and extending from end to end, and carrying the two daggers, k , which, when elevated at their outer ends, fail to abut against lugs on top of the protector-bar c when the lay moves forward, but which, when not thus elevated, do abut against said lugs and move the bar, thereby operating the shipper, and also the braking mechanism, through the link and bell-crank lever d' , on which the segmental roller D is mounted.

At each end of the dagger-shaft i is a vertical lever, l , the upper end of which is normally in contact with the outer surface of the free end of the hinged side g^1 of a shuttle-box, in each instance.

The daggers are normally maintained in a depressed position, and the vertical levers l maintained in contact with the hinged shuttle-box sides by retractile spiral springs, as at m , the upper and lower ends of which are, respectively, connected with arms on the dagger-rod i , which project forward, and with laterally-projecting studs on the standards of the lay-frame. These studs also constitute the pivots on which the reed-frame is mounted.

When a shuttle enters its box it is obvious that the dagger-shaft will be rocked, and the daggers so elevated that they will pass over

the lugs on the protector-bar; but when the shuttle fails to fully enter either box, the dagger-shaft will not be rocked, and therefore the protector-bar will operate the brake.

When it is desirable to remove a reed from its frame the lay is pulled forward until the reed-frame is sufficiently to the rear thereof, and then these two parts may readily be held thus separated by simply turning the segmental roller so that the end of the strap will bear against the drum.

It will be seen that by dispensing with the fulcrum-rod heretofore used by me I simplify the construction, lessen the cost, and render the operation of this portion of the stop-motion more positive and reliable, and at the same time lessen the weight carried by the lay, which is an important item in high-speed looms.

I have stated that it is in this connection merely incidental in my present loom that I have the rear instead of the front sides of the shuttle-boxes hinged, because it is obvious that the front side may as well be hinged and used, in which case the vertical lever *l* would be mounted on the dagger-rod *i* passing beneath the lay-bed, and thence upward; but in such case the outer ends of the daggers would normally be in an elevated position, so that when a shuttle entered the box the dagger would be depressed and pass beneath the protector-bar, or the lugs thereon, and when the shuttle failed to enter the normally-elevated daggers would strike the bar and stop the loom.

Having thus described my invention, I claim as new and desire to secure by Letters Patent—

1. The combination, with a lay having shuttle-boxes with hinged sides and a spring reed-frame, of a dagger rod or shaft controlled by a spring mounted on the reed-frame and provided with levers which engage with the hinged sides of the shuttle-boxes, substantially as described.

2. The combination, with a spring reed-frame and a shuttle-box having one side thereof hinged on a pivot which is laterally adjustable, of a bar on the spring reed-frame, substantially as described, whereby the rearward movement of the hinged side or "swell" of the shuttle-box is limited by the bar on the reed-frame, is maintained in proper relations with the face-line of the reed, and a thorough frictional contact secured with both sides of the shuttle; as set forth.

3. A loom-lay, slotted to receive a picker-staff, and provided at the ends of the slots with pockets formed in the lay for the reception of cushions, substantially as described, whereby a cushion for relieving the shock of the staff may be readily inserted or removed, and require no securing devices, as set forth.

JESSE D. COTTRELL.

Witnesses:

GEO. E. BAMFORD,
FRANCIS A. BURNHAM.