



(12) **DEMANDE DE BREVET CANADIEN
CANADIAN PATENT APPLICATION**

(13) **A1**

(86) Date de dépôt PCT/PCT Filing Date: 2019/06/17
 (87) Date publication PCT/PCT Publication Date: 2019/12/26
 (85) Entrée phase nationale/National Entry: 2021/07/09
 (86) N° demande PCT/PCT Application No.: US 2019/037485
 (87) N° publication PCT/PCT Publication No.: 2019/245971
 (30) Priorité/Priority: 2018/06/18 (US16/010,633)

(51) Cl.Int./Int.Cl. *B60N 2/28* (2006.01),
B60R 21/015 (2006.01), *B60R 22/18* (2006.01),
B60R 22/185 (2006.01), *B60R 22/19* (2006.01)
 (71) Demandeur/Applicant:
 INDIANA MILLS & MANUFACTURING, INC., US
 (72) Inventeur/Inventor:
 GEIST, CHRISTOPHER, US
 (74) Agent: SMART & BIGGAR LLP

(54) Titre : DISPOSITIF D'AJUSTEMENT DE VERROUILLAGE DE BASCULEMENT AVEC INDICATEUR DE TENSION
 (54) Title: TILT-LOCK ADJUSTER WITH TENSION INDICATOR

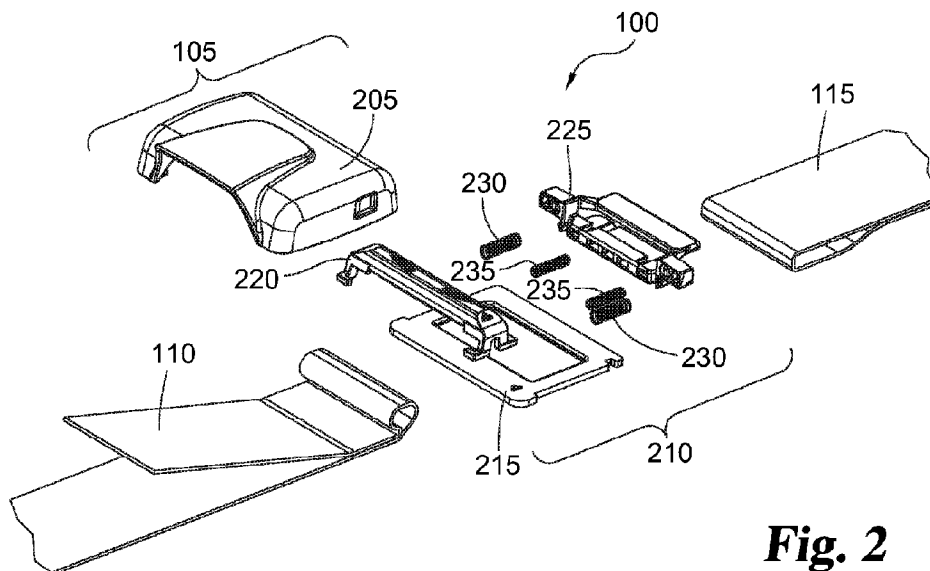

Fig. 2

(57) **Abrégé/Abstract:**

A tilt-lock adjuster system includes a tilt-lock adjuster that is used to tighten and loosen webbing. The tilt-lock adjuster includes an indicator configured to indicate when proper tension is applied to the webbing. The tilt-lock adjuster has a frame to which the indicator is slidably coupled and a web bar slidably coupled to the frame. The web bar is asymmetric for one way assembly with the frame. The web bar has a web engagement notch that is concave for enhancing locking of the webbing to the frame. The web bar has a frame guide slidably engaged to the frame. The frame defines a web opening in which the frame engagement ledge extends. The frame guide of the web bar includes a key guide foot. The frame has an orientation notch configured to receive the key guide foot of the web bar.

(12) INTERNATIONAL APPLICATION PUBLISHED UNDER THE PATENT COOPERATION TREATY (PCT)

(19) World Intellectual Property
Organization
International Bureau



(10) International Publication Number
WO 2019/245971 A1

(43) International Publication Date
26 December 2019 (26.12.2019)

(51) International Patent Classification:

B60N 2/28 (2006.01) *B60R 22/185* (2006.01)
B60R 21/015 (2006.01) *B60R 22/19* (2006.01)
B60R 22/18 (2006.01)

(21) International Application Number:

PCT/US2019/037485

(22) International Filing Date:

17 June 2019 (17.06.2019)

(25) Filing Language:

English

(26) Publication Language:

English

(30) Priority Data:

16/010,633 18 June 2018 (18.06.2018) US

(71) Applicant: **INDIANA MILLS & MANUFACTURING, INC** [US/US]; 18881 IMMI Way, Westfield, IN 46074 (US).

(72) Inventor: **GEIST, Christopher**; 561 Stafford Drive, Westfield, IN 46074 (US).

(74) Agent: **SCHMAL, Charles, P.** et al.; Woodard, Emhardt, Henry, Reeves & Wagner, LLP, 111 Monument Circle, Suite 3700, Indianapolis, IN 46204 (US).

(81) Designated States (*unless otherwise indicated, for every kind of national protection available*): AE, AG, AL, AM, AO, AT, AU, AZ, BA, BB, BG, BH, BN, BR, BW, BY, BZ, CA, CH, CL, CN, CO, CR, CU, CZ, DE, DJ, DK, DM, DO, DZ, EC, EE, EG, ES, FI, GB, GD, GE, GH, GM, GT, HN, HR, HU, ID, IL, IN, IR, IS, JO, JP, KE, KG, KH, KN, KP, KR, KW, KZ, LA, LC, LK, LR, LS, LU, LY, MA, MD, ME, MG, MK, MN, MW, MX, MY, MZ, NA, NG, NI, NO, NZ, OM, PA, PE, PG, PH, PL, PT, QA, RO, RS, RU, RW, SA, SC, SD, SE, SG, SK, SL, SM, ST, SV, SY, TH, TJ, TM, TN, TR, TT, TZ, UA, UG, US, UZ, VC, VN, ZA, ZM, ZW.

(84) Designated States (*unless otherwise indicated, for every kind of regional protection available*): ARIPO (BW, GH, GM, KE, LR, LS, MW, MZ, NA, RW, SD, SL, ST, SZ, TZ, UG, ZM, ZW), Eurasian (AM, AZ, BY, KG, KZ, RU, TJ, TM), European (AL, AT, BE, BG, CH, CY, CZ, DE, DK, EE, ES, FI, FR, GB, GR, HR, HU, IE, IS, IT, LT, LU, LV, MC, MK, MT, NL, NO, PL, PT, RO, RS, SE, SI, SK, SM,

(54) Title: TILT-LOCK ADJUSTER WITH TENSION INDICATOR

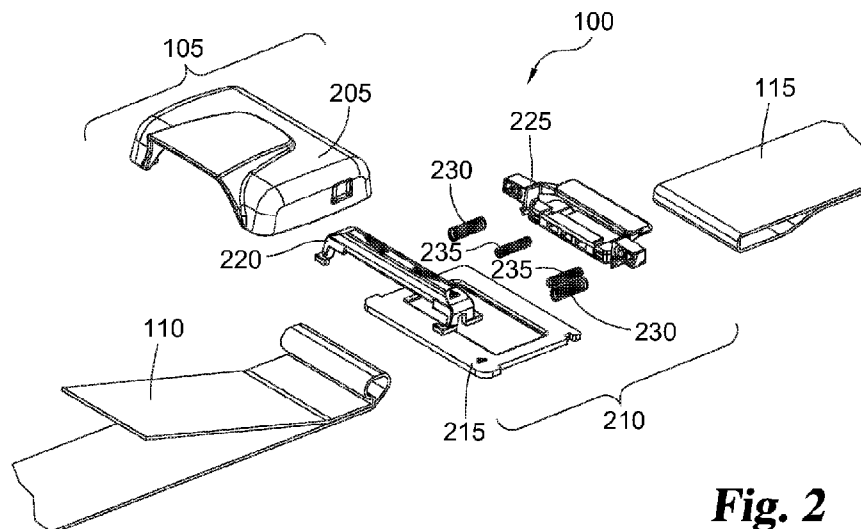

(57) Abstract: A tilt-lock adjuster system includes a tilt-lock adjuster that is used to tighten and loosen webbing. The tilt-lock adjuster includes an indicator configured to indicate when proper tension is applied to the webbing. The tilt-lock adjuster has a frame to which the indicator is slidably coupled and a web bar slidably coupled to the frame. The web bar is asymmetric for one way assembly with the frame. The web bar has a web engagement notch that is concave for enhancing locking of the webbing to the frame. The web bar has a frame guide slidably engaged to the frame. The frame defines a web opening in which the frame engagement ledge extends. The frame guide of the web bar includes a key guide foot. The frame has an orientation notch configured to receive the key guide foot of the web bar.

[Continued on next page]



WO 2019/245971 A1

WO 2019/245971 A1 

TR), OAPI (BF, BJ, CF, CG, CI, CM, GA, GN, GQ, GW,
KM, ML, MR, NE, SN, TD, TG).

Declarations under Rule 4.17:

- *as to applicant's entitlement to apply for and be granted a patent (Rule 4.17(ii))*

Published:

- *with international search report (Art. 21(3))*

TILT-LOCK ADJUSTER WITH TENSION INDICATOR

BACKGROUND

5 In child car seats and other vehicular restraint systems, it can be difficult to determine whether the restraint systems are properly secured to the vehicle. For example in Lower Anchors and Tethers for Children (LATCH) systems, an adjustable belt is typically used to secure the car seat to the lower anchors and/or the tether anchors inside the vehicle. If the belt is too loose or otherwise improperly secured, the car seat may not properly function during an
10 accident. Belt tension indicators have been proposed as separate components or incorporated into button actuated adjusters, but these systems have a number of significant drawbacks. For example, these type of indicator systems can be expensive to manufacture, difficult to use, and may not be readily visible in the tight confines where car seats are typically installed.

 Thus, there is a need for improvement in this field.

SUMMARY

A unique tilt-lock adjuster system has been developed. As compared to button type adjusters, the tilt-lock adjuster is easier to use. Moreover, the system incorporates a unique indicator that is not only visible from the top but also from the sides which can be especially helpful in tight environments such as when installing a car seat in the back seat of a vehicle. The system further includes a unique web bar system that simplifies assembly as well as ensures that the adjuster belt is firmly secured. Traditional web bars are typically flat because the web bars are manufactured using a stamping process that limits the geometry of the web bars. Among other things, this limited geometry impacts how strongly the web is secured. The web bar in one form of this tilt-lock adjuster system is made from a casting process that allows the web bar to have a more complicated geometry that facilitates better clamping between the web bar and frame as well as allows the web bar to have an asymmetric shape for facilitating installation in only one orientation. In one particular form, the web bar is manufactured using cast zinc.

Aspect 1 generally concerns a system that includes a tension indicator on a tilt-lock adjuster.

Aspect 2 generally concerns the system of aspect 1 in which the tilt-lock adjuster includes a cast web bar.

Aspect 3 generally concerns the system of aspect 2 in which the web bar is asymmetric for one way assembly.

Aspect 4 generally concerns the system of aspect 3 in which the web bar has a concave bar notch for better locking.

Aspect 5 generally concerns the system of aspect 4 in which the web bar has a frame guide slidably engaged to a frame.

Aspect 6 generally concerns the system of aspect 5 in which the web bar has a frame engagement ledge that defines a guide gap that is smaller than the thickness of the frame.

Aspect 7 generally concerns the system of aspect 6 in which the frame defines a web opening in which the frame engagement ledge extends.

Aspect 8 generally concerns the system of aspect 7 in which the frame has an orientation notch configured to receive a key guide foot of the web bar.

Aspect 9 generally concerns the system of aspect 2 in which the web bar and indicator move independently.

Aspect 10 generally concerns the system of aspect 9 in which the tilt-lock adjuster includes one or more web bar springs positioned between the web bar and indicator.

Aspect 11 generally concerns the system of aspect 1 in which the indicator includes side and top indicators.

5 Aspect 12 generally concerns the system of aspect 11 in which the side indicator has a window that is asymmetric or angled towards the viewer.

Aspect 13 generally concerns the system of aspect 11 in which the side indicator includes lateral tension indicators.

10 Aspect 14 generally concerns the system of aspect 11 in which the indicator includes an indicator guide flange that is recessed relative to the top indicator.

Aspect 15 generally concerns the system of aspect 1 in which the indicator includes one or more indicator springs to bias the indicator in a retracted position.

Aspect 16 generally concerns the system of aspect 15 in which the indicator includes one or more indicator spring seat cavities where the indicator springs are secured.

15 Aspect 17 generally concerns the system of aspect 1 in which the tilt-lock adjuster includes a web bar and a frame with orientation guides.

Aspect 18 generally concerns the system of aspect 1 in which the tilt-lock adjuster includes a cover with one or more ribs defining an indicator cavity.

20 Aspect 19 generally concerns the system of any previous aspect in which the tilt-lock adjuster includes a cast web bar.

Aspect 20 generally concerns the system of any previous aspect in which the web bar is asymmetric for one way assembly.

Aspect 21 generally concerns the system of any previous aspect in which the web bar has a concave bar notch for better locking.

25 Aspect 22 generally concerns the system of any previous aspect in which the web bar has a frame guide slidably engaged to a frame.

Aspect 23 generally concerns the system of any previous aspect in which the web bar has a frame engagement ledge that defines a guide gap that is smaller than the thickness of the frame.

30 Aspect 24 generally concerns the system of any previous aspect in which the frame defines a web opening in which the frame engagement ledge extends.

Aspect 25 generally concerns the system of any previous aspect in which the frame has an orientation notch configured to receive a key guide foot of the web bar.

Aspect 26 generally concerns the system of any previous aspect in which the web bar and indicator move independently.

Aspect 27 generally concerns the system of any previous aspect in which the tilt-lock adjuster includes one or more web bar springs positioned between the web bar and indicator.

5 Aspect 28 generally concerns the system of any previous aspect in which the indicator includes side and top indicators.

Aspect 29 generally concerns the system of any previous aspect in which the side indicator has a window that is asymmetric or angled towards the viewer.

10 Aspect 30 generally concerns the system of any previous aspect in which the side indicator includes lateral tension indicators.

Aspect 31 generally concerns the system of any previous aspect in which the indicator includes an indicator guide flange that is recessed relative to the top indicator.

Aspect 32 generally concerns the system of any previous aspect in which the indicator includes one or more indicator springs to bias the indicator in a retracted position.

15 Aspect 33 generally concerns the system of any previous aspect in which the indicator includes one or more indicator spring seat cavities where the indicator springs are secured.

Aspect 34 generally concerns the system of any previous aspect in which the tilt-lock adjuster includes a web bar and a frame with orientation guides.

20 Aspect 35 generally concerns the system of any previous aspect in which the tilt-lock adjuster includes a cover with one or more ribs defining an indicator cavity.

Further forms, objects, features, aspects, benefits, advantages, and embodiments of the present invention will become apparent from a detailed description and drawings provided herewith.

BRIEF DESCRIPTION OF THE DRAWINGS

FIG. 1 is a perspective view of a tilt-lock adjuster system according to one example.

FIG. 2 is an exploded view of the FIG. 1 tilt-lock adjuster system.

FIG. 3 is a first side view of the FIG. 1 tilt-lock adjuster system in a tensioned
5 configuration.

FIG. 4 is a second side view of the FIG. 1 tilt-lock adjuster system in an untensioned
configuration.

FIG. 5 is a top view of the FIG. 1 tilt-lock adjuster system.

FIG. 6 is a bottom view of the FIG. 1 tilt-lock adjuster system.

FIG. 7 is a cross-sectional view of the FIG. 1 tilt-lock adjuster system as taken along
10 line 7-7 in FIG. 5.

FIG. 8 is a top perspective view of a cover for the FIG. 1 tilt-lock adjuster system.

FIG. 9 is a bottom perspective view of the FIG. 8 cover.

FIG. 10 is a bottom view of the FIG. 8 cover.

FIG. 11 is a cross-sectional view of the FIG. 8 cover as taken along line 11-11 in FIG.
15 10.

FIG. 12 is a side view of the FIG. 8 cover.

FIG. 13 is a cross-sectional view of the FIG. 8 cover as taken along line 13-13 in FIG.
12.

FIG. 14 is a top perspective view of the FIG. 1 tilt-lock adjuster system with the FIG.
20 8 cover removed.

FIG. 15 is a top perspective view of a lock adjuster assembly.

FIG. 16 is a bottom perspective view of the FIG. 15 lock adjuster assembly.

FIG. 17 is a top view of a frame in the FIG. 15 lock adjuster assembly.

FIG. 18 is a bottom view of the FIG. 17 frame.
25

FIG. 19 is a side view of the FIG. 17 frame.

FIG. 20 is a top perspective view of a web bar in the FIG. 15 lock adjuster assembly.

FIG. 21 is a bottom perspective view of the FIG. 20 web bar.

FIG. 22 is a bottom view of the FIG. 20 web bar.

FIG. 23 is a top view of the FIG. 20 web bar.
30

FIG. 24 is a rear view of the FIG. 20 web bar.

FIG. 25 is a front view of the FIG. 20 web bar.

FIG. 26 is a cross-sectional view of the FIG. 20 web bar as taken along line 26-26 in FIG. 25.

FIG. 27 is a cross-sectional view of the FIG. 20 web bar as taken along line 27-27 in FIG. 25.

5 FIG. 28 is a top perspective view of an indicator in the FIG. 15 lock adjuster assembly.

FIG. 29 is a front perspective view of the FIG. 28 indicator.

FIG. 30 is a front view of the FIG. 28 indicator.

FIG. 31 is a rear view of the FIG. 28 indicator.

10 FIG. 32 is a top view of the FIG. 28 indicator.

FIG. 33 is a bottom view of the FIG. 28 indicator.

FIG. 34 is a side view of the FIG. 28 indicator.

FIG. 35 is a cross-sectional view of the FIG. 28 indicator as taken along line 35-35 in FIG. 32.

15 FIG. 36 is a partial cross-sectional view of during insertion of the FIG. 20 web bar on the FIG. 17 frame.

FIG. 37 is a partial cross-sectional view of during seating of the FIG. 20 web bar on the FIG. 17 frame.

FIG. 38 is a top perspective view of the FIG. 20 web bar seated on the FIG. 17 frame.

20 FIG. 39 is a top perspective view of during mounting of the FIG. 20 web bar on the FIG. 17 frame.

FIG. 40 is a top perspective view of during mounting of the FIG. 28 indicator on the FIG. 17 frame.

25 FIG. 41 is a partial cross-sectional view of during insertion of the FIG. 20 web bar backwards on the FIG. 17 frame.

FIG. 42 is a partial cross-sectional view of the FIG. 20 web bar prevented from being seated backwards on the FIG. 17 frame.

DETAILED DESCRIPTION OF THE SELECTED EMBODIMENTS

For the purpose of promoting an understanding of the principles of the invention, reference will now be made to the embodiments illustrated in the drawings and specific language will be used to describe the same. It will nevertheless be understood that no
5 limitation of the scope of the invention is thereby intended. Any alterations and further modifications in the described embodiments, and any further applications of the principles of the invention as described herein are contemplated as would normally occur to one skilled in the art to which the invention relates. One embodiment of the invention is shown in great detail, although it will be apparent to those skilled in the relevant art that some features that
10 are not relevant to the present invention may not be shown for the sake of clarity.

The reference numerals in the following description have been organized to aid the reader in quickly identifying the drawings where various components are first shown. In particular, the drawing in which an element first appears is typically indicated by the left-most digit(s) in the corresponding reference number. For example, an element identified by a
15 "100" series reference numeral will likely first appear in FIG. 1, an element identified by a "200" series reference numeral will likely first appear in FIG. 2, and so on.

FIG. 1 shows a top perspective view of a tilt-lock adjuster system 100 according to one example. As shown, the tilt-lock adjuster system 100 includes a tilt-lock adjuster 105 with a tension web 110 and fixed web 115 attached at opposite ends. In one example, the
20 ends of the tension web 110 and fixed web 115 are secured to latch type clips which in turn are secured to latch anchors in a vehicle. It should be recognized that the tilt-lock adjuster system 100 can be used in other situations. The tension web 110 is looped in the tilt-lock adjuster 105. By pulling on a belt adjuster end 120 of the tension web 110, a user is able to tighten tension web 110 and fixed web 115. The tilt-lock adjuster 105 is configured to hold
25 the tension web 110 in the tensioned state. The tilt-lock adjuster 105 can be lifted to release the tension in the tension web 110 and fixed web 115.

FIG. 2 shows an exploded view of the tilt-lock adjuster system 100. As can be seen, the tilt-lock adjuster 105 includes a cover 205 that covers an adjuster indicator assembly 210 to which the tension web 110 and fixed web 115 are secured. The cover 205 includes a frame
30 215, a web bar 220 slidably coupled to the frame 215, and an indicator 225 slidably coupled to the frame 215 to indicate whether the tension web 110 is properly tensioned. One or more web bar springs 230 are disposed between the web bar 220 and the indicator 225. In one form, the web bar springs 230 act as a buffer by biasing apart the web bar 220 and indicator

225. In the illustrated example, the adjuster indicator assembly 210 has two (2) web bar springs 230, but in other examples, the adjuster indicator assembly 210 can have more or less web bar springs 230 than is shown. The adjuster indicator assembly 210 further includes one or more indicator springs 235 that bias the indicator 225 to a retracted position indicating that insufficient tension has been applied to the fixed web 115. In the depicted example, the adjuster indicator assembly 210 has two (2) indicator springs 235, but in other examples, the adjuster indicator assembly 210 can have more or less indicator springs 235 than is shown. In one example, the cover 205 and indicator 225 are made of plastic, and the frame 215, web bar 220, web bar springs 230, and indicator springs 235 are made of metal. However, these components can be made of other types of materials and/or with different combinations of materials in other examples.

Looking at FIGS. 3, 4, 5, and 6, the cover 205 has one or more lateral windows 305 on opposing lateral sides through which one or more lateral tension indicators 310 of the indicator 225 can be viewed when the tilt-lock adjuster system 100 is adequately tensioned. As will be explained in greater detail below, the lateral windows 305 have an asymmetric shape so as to enhance visibility such as for example when the fixed web 115 is secured to a tether via a latch clip or in some other manner. Normally, but not always, the fixed web 115 is relatively short as compared to the tension web 110, and the fixed web 115 is secured in relatively close or tight conditions such as a lower anchor in a vehicle seat. The lateral windows 305 are angled away from the fixed web 115 (and the vehicle seat) so as to enhance operator visibility of the lateral tension indicators 310 when tightening the tension web 110 with the tilt-lock adjuster 105. When the tension web 110 reaches sufficient tension, not only are the lateral tension indicators 310 of the indicator 225 visible, a longitudinal tension indicator 315 of the indicator 225 visible from the top. FIG. 4 shows the indicator 225 in a retracted state where insufficient tension has been applied to the tilt-lock adjuster system 100. As can be seen, the lateral tension indicators 310 and longitudinal tension indicator 315 are not visible to the user when the indicator 225 is in a retracted state. FIGS. 3 and 5 show the indicator 225 in an extended or activated position when proper tension is applied to the tilt-lock adjuster system 100. In one form, the lateral tension indicators 310 and longitudinal tension indicator 315 are colored, marked, shaped, and/or otherwise indicated that sufficient tension has been applied. For instance, at least the lateral tension indicators 310 and longitudinal tension indicator 315 are colored green so as indicate proper tensioning, and in other variations, the entire indicator 225 is green such as by being made from injection

molded green plastic. It should be recognized that in other variations other types of indicators can be used to signify sufficient web tensioning. As can be seen in FIG. 6, the tilt-lock adjuster 105 has a longitudinal axis 605 that extends generally in the same direction along the tilt-lock adjuster 105, tension web 110, and fixed web 115, and a lateral axis 610 that extends
5 perpendicular to the longitudinal axis 605.

A cross-sectional view of the tilt-lock adjuster system 100 as taken along line 7-7 in FIG. 5 is shown in FIG. 7. As shown, the tension web 110 is wrapped around the web bar 220. The fixed web 115 is wrapped around the indicator 225 and through the frame 215. The web bar 220 and indicator 225 are able to slide or move independently of one another. Again,
10 in one example, the web bar springs 230 bias the web bar 220 and indicator 225 away from one another. In further variations, the web bar springs 230 bias the web bar 220 so that the belt adjuster end 120 of the tension web 110 is cinched between the web bar 220 and the frame 215. In still yet other examples, the web bar springs 230 are eliminated altogether or replaced with a different type of biasing mechanism. The engagement between the frame 215
15 and web bar 220 holds the tension web 110 in place at the desired tension. The cover 205 defines a grip cavity 705 where a user is able to lift the end of the tilt-lock adjuster 105 by the tension web 110 in a direction indicated by arrow 707 to release tension from the tension web 110. The cover 205 further defines a web bar cavity 710 and an indicator cavity 715 in the tilt-lock adjuster 105 that is separated by a stop member 720. The web bar cavity 710 helps to
20 guide the movement of the web bar 220, and the indicator cavity 715 helps with guiding the movement of the indicator 225 inside the tilt-lock adjuster 105. The stop member 720 inhibits the web bar 220 and indicator 225 from contacting one another.

Referring again to FIGS. 3, 5, 6, and 7, the tilt-lock adjuster system 100 is tightened by pulling the belt adjuster end 120 generally in a direction indicated by arrow 725 along the
25 longitudinal axis 605. While tension is applied between the tension web 110 and fixed web 115, the indicator 225 compresses the indicator springs 235 against the frame 215 in the tilt-lock adjuster 105 (FIG. 2) such that the indicator 225 moves in the longitudinal axis 605 to the extended position. When sufficient tension is applied to overcome the spring force of the indicator springs 235, the indicator 225 moves in the direction along the longitudinal axis 605
30 as indicated by arrow 730 in FIG. 7 to the extended position where the lateral tension indicators 310 and longitudinal tension indicator 315 are visible. To loosen or release the tension web 110 and fixed web 115, the user grips the cover 205 at the grip cavity 705 and

lifts in the direction generally indicated by arrow 707. The stop member 720 disengages from the indicator cavity 715 to allow the tension web 110 to slide in between.

FIGS. 8 and 9 respectively show top and bottom perspective views of the cover 205. As illustrated, the cover 205 has a cover body 800 with a grip end 805 and an indicator end 810 with one or more lateral sidewalls 815 extending in between. A grip protrusion 820 extends from the cover body 800. At the grip end 805, the grip protrusion 820 defines in part the grip cavity 705 where the user is able to lift the tilt-lock adjuster 105 in order to release the tension web 110. In one form, the cover 205 is made from injection molded plastic, but in other variations, the cover 205 can be made from different materials or a combination of materials. For instance, the grip end 805 of the cover body 800 can be made of metal to provide further strength. The cover body 800 at the indicator end 810 defines an indicator notch 825 through which the longitudinal tension indicator 315 of the indicator 225 extends. The lateral windows 305 are defined in the lateral sidewalls 815. In the illustrated example, the lateral sidewalls 815 are configured to be generally the same, but in other examples, the lateral sidewalls 815 can be different from one another.

Turning to FIGS. 9, 10, and 11, the cover body 800 has one or more ribs 905 that face the adjuster indicator assembly 210. Each of the ribs 905 has a tension web section 910 and an indicator section 915 spaced apart from the ribs 905 by the stop member 720. Together the tension web section 910 of each of the ribs 905 defines the web bar cavity 710, and the indicator section 915 of each of the ribs 905 form the indicator cavity 715. The tension web section 910 of each indicator section 915 has a scooped or curved shape to facilitate smooth movement of the tension web 110 within the tilt-lock adjuster 105. On each of the ribs 905, the indicator section 915 helps to smoothly guide the indicator 225. The cover body 800 of the cover 205 has one or more frame clips 920 with corresponding frame standoffs 925 that together define one or more frame notches 930 in which the frame 215 is secured. In the illustrated example, the cover 205 has four (4) frame standoffs 925 located at the corners of the frame 215, but other examples can have fewer or more frame standoffs 925 secured at other locations on the frame 215.

As noted before, the lateral windows 305 have an asymmetric shape that allows the lateral tension indicators 310 of the indicator 225 to be visible even when secured in cramped conditions. Looking at FIGS. 12 and 13, the lateral windows 305 in the lateral sidewalls 815 are defined by a trailing jamb edge 1205 and a leading jamb edge 1210 that is located opposite the trailing jamb edge 1205 as well as a head jamb edge 1215 and a sill edge 1220

extending between the trailing jamb edge 1205 and the leading jamb edge 1210. Typically, but not always, the tilt-lock adjuster 105 during tensioning is viewed from the top and from the grip end 805. As shown, the trailing jamb edge 1205 is beveled along the longitudinal axis 605 towards the grip end 805 as indicated by arrow 725 in FIG. 12. Likewise, the head jamb edge 1215 is beveled towards the top of the cover 205. In the illustrated example, the leading jamb edge 1210 and sill edge 1220 are not beveled. As depicted in FIG. 13, the cover 205 has an interior surface 1305 and an exterior surface 1310. The trailing jamb edge 1205 extends at a trailing jamb angle 1315 relative to the interior surface 1305 that is an acute angle (i.e., less than 90 degrees). The head jamb edge 1215 similarly extends at an acute angle relative to the interior surface 1305. In one form, the trailing jamb angle 1315 for the trailing jamb edge 1205 and the head jamb edge 1215 are less than 90 degrees, and more specifically, less than 45 degrees. As can be seen, the leading jamb edge 1210 and the sill edge 1220 are angled generally perpendicular to the interior surface 1305 in the depicted example. In the illustrated example, the lateral windows 305 are openings that extend completely through the lateral sidewalls 815 from the exterior surface 1310 to the interior surface 1305. In other examples, the lateral windows 305 can include transparent or semi-transparent material, such as clear plastic, that allows to the lateral tension indicators 310 of the indicator 225 to be visible to the user.

Referring now to FIGS. 14, 15, and 16, the frame 215 has a frame orientation guide 1405, and the web bar 220 has a web bar orientation guide 1410 that are used to properly align the web bar 220 on the frame 215 during assembly. In the illustrated example, the frame orientation guide 1405 and web bar orientation guide 1410 are stamped marks on the frame 215 and the web bar 220, but in other examples, the frame orientation guide 1405 and web bar orientation guide 1410 can include different types of markings such as stickers, ink marks, and the like. As should be appreciated, the frame orientation guide 1405 and web bar orientation guide 1410 allow an assembly line worker and/or a computerized vision system to readily recognize that both the frame orientation guide 1405 and web bar orientation guide 1410 should be located on the same side for proper orientation of the web bar 220 relative to the frame 215 during assembly. In another variation, having the frame orientation guide 1405 and the web bar orientation guide 1410 on opposite sides can indicate proper orientation of the web bar 220 relative to the frame 215 during assembly. As will be explained in greater detail below, the frame 215 further includes an orientation notch 1415 that ensures that the web bar 220 can only be properly secured to the frame 215 at the required orientation.

As shown in FIGS. 17, 18, and 19, the frame 215 has a web opening 1705 in which the tension web 110, fixed web 115, and indicator 225 are received. Around the web opening 1705, the frame 215 has an insertion rail 1710, a stop rail 1715, an alignment stile 1720, and a guide stile 1725. At the stop rail 1715, the frame 215 has one or more stop flanges 1730
5 configured to limit the movement of the web bar 220. The frame 215 further has a peripheral edge 1735 and an internal edge 1737 that surround the web opening 1705. As will be explained in greater detail below, the frame 215 and the web bar 220 have, along with their various structural features, specific dimensional relationships that inhibit the web bar 220 from being installed on the frame 215 at the wrong orientation. Among these dimensions, the
10 insertion rail 1710 has an insertion rail width 1740 that is sized to inhibit improper installation of the web bar 220. The peripheral edge 1735 along the alignment stile 1720 has the orientation notch 1415 which defines an alignment tab 1745. The alignment tab 1745 has a tab width 1750, and the orientation notch 1415 has a notch width 1755, as is depicted in FIG. 17. As measured from the orientation notch 1415 to the internal edge 1737 of the web
15 opening 1705, the insertion rail 1710 has a notch window distance 1760. Together, the notch width 1755 and notch window distance 1760 form a ledge clearance distance 1762. In the depicted example, the orientation notch 1415 is formed along the same side as the frame orientation guide 1405 so that the assembly line worker or robot only has to look at one side to confirm correct installation. Typically, but not always, the web bar 220 hits the end of the
20 web opening 1705 just before the web bar 220 engages the stop flanges 1730, but in other examples, the web bar 220 can hit the stop flanges 1730 first. As shown, the stop flanges 1730 are positioned at a stop window distance 1765 from the proximal edge of the web opening 1705. The web opening 1705 has a window width 1770 that is at least as wide as the tension web 110, if not wider, to receive the tension web 110.

25 The frame 215 is structured so that the web bar 220 can be slid onto the frame 215 from one end. Specifically, the stop rail 1715 is sized to prevent the web bar 220 from being slid onto the stop rail 1715 of the frame 215. As measured from the ends of the stop flanges 1730, the stop rail 1715 has a stop rail width 1805. It should be recognized that the stop rail width 1805 is sized large enough such that the web bar 220 is unable to be slid onto the stop
30 rail 1715 of the frame 215. At the other end, the insertion rail 1710 has an insertion end width 1810 as measured from the peripheral edge 1735 of the alignment stile 1720 and guide stile 1725 that allows the web bar 220 to be slid onto the frame 215. As illustrated in FIG. 19, the frame 215 has a frame thickness 1905 that is sized to facilitate the web bar 220 being

installed in the proper orientation. Both the alignment stile 1720 and guide stile 1725 have a stile width 1775 as measured from the peripheral edge 1735 of the frame 215 to the web opening 1705. In the illustrated example, the stile width 1775 of the alignment stile 1720 and guide stile 1725 are the same, but in other examples, the stile width 1775 of the alignment
5 stile 1720 and guide stile 1725 can be different.

Looking at FIGS. 20 and 21, the web bar 220 includes a frame guide 2005 configured to retain the web bar 220 on the frame 215 as the web bar 220 slides along the frame 215, and the web bar 220 also has a bar 2010 around which the tension web 110 is looped. The frame guide 2005 has an asymmetric shape that facilitates the web bar 220 being attached to the
10 frame 215 in only one orientation. In the illustrated example, the frame guide 2005 has one or more frame guide legs 2012 with one or more frame guide feet 2015 positioned on opposing ends of the bar 2010 and extending towards one another. In the depicted example, the frame guide legs 2012 are L-shaped, and the frame guide legs 2012 connect the bar 2010 to the frame guide feet 2015. The frame guide feet 2015 hook underneath the alignment stile 1720
15 and guide stile 1725 to retain the web bar 220 on the frame 215 in a sliding manner. In the illustrated example, the frame guide 2005 is asymmetric in that the frame guide 2005 has three (3) frame guide feet 2015, that is, two (2) on one side and one (1) on the other side, but in other examples, the frame guide 2005 can be asymmetric in other manners such as by having a different number of frame guide feet 2015 (or frame guide legs 2012) and/or by
20 having the frame guide feet 2015 shaped differently. Generally speaking, the frame guide feet 2015 of the frame guide 2005 form a key that allows the web bar 220 to be solidly seated on the frame 215 in only a single way.

At each end of the bar 2010 proximal the frame guide legs 2012, the frame guide feet 2015 along with a corresponding stile engaging surface 2017 of the bar 2010 form one or
25 more frame stile slots 2020 in which the alignment stile 1720 and guide stile 1725 are slidably received. In the illustrated example, the stile engaging surface 2017 is generally flat to promote smooth sliding of the web bar 220. Above the frame stile slots 2020, the bar 2010 has one or more spring seat cavities 2025 in which the web bar springs 230 are seated. When the web bar 220 is installed in the adjuster indicator assembly 210, the spring seat cavities
30 2025 face the indicator 225 so that the web bar springs 230 are positioned between the web bar 220 and indicator 225. In the illustrated example, the web bar 220 has two spring seat cavities 2025 positioned at opposite ends of the bar 2010 proximal to the frame guide feet 2015 so as to coincide with the pair of web bar springs 230. With the web bar springs 230

and spring seat cavities 2025 configured in such a way, an even resilient force is applied to the web bar 220 so as to avoid the web bar 220 being crooked relative to the frame 215. If the web bar 220 were crooked, the tension web 110 might not be secured or released properly, and the tension web 110 may become damaged. When the tension web 110 is secured, the frame guide legs 2012 facing the stop flanges 1730 are able to hook underneath the stop flanges 1730 of the frame 215 so as to further bolster support of the web bar 220 by minimizing rotation of the web bar 220 when further tension is applied to the tension web 110. As for example shown in FIGS. 16, 17, and 18, the side of the frame guide feet 2015 having two of the frame guide feet 2015 faces the stop flanges 1730 so that the frame guide legs 2012 that are L-shaped are able to hook underneath the stop flanges 1730. In other words, the side of the web bar 220 with the two (2) frame guide legs 2012 and frame guide feet 2015 face away from the indicator 225 when assembled, and as such, extend opposite the spring seat cavities 2025.

As mentioned before, traditional web bars are typically flat because they are manufactured using a stamping process that limits the geometry of the web bars. Among other things, this limited geometry impacts how strongly the web is secured during tension. The web bar 220 in the illustrated example is made from a casting process. This casting process allows web bar 220 to have a more complicated geometry that facilitates better clamping, sliding, and releasing of the tension web 110 between the web bar 220 and frame 215 as well as allows the web bar 220 to have an asymmetric shape of the type explained before. In one particular form, the web bar 220 is manufactured using a cast zinc process, but the web bar 220 can be cast from other materials such as steel. For instance, in another variation, the web bar 220 is manufactured using a metalized 3D printing technique.

Turning now to FIGS. 22 and 23, each of the frame guide feet 2015 has an exterior surface 2205 and an interior surface 2210. As measured between the exterior surface 2205 and interior surface 2210, each of the frame guide feet 2015 has a foot guide width 2215. Opposite the end of the bar 2010 without one of the frame guide legs 2012, the frame guide feet 2015 include a key guide foot 2217 that is configured to slide through the orientation notch 1415 in the frame 215 during proper assembly. At least the foot guide width 2215 of the key guide foot 2217 is no more than the notch width 1755 of the orientation notch 1415 in the frame 215 (FIG. 17) so that key guide foot 2217 is able to slide through the orientation notch 1415. In one form, the foot guide width 2215 of the key guide foot 2217 is less than the notch width 1755 of the orientation notch 1415 in the frame 215. The bar 2010 has a bar

exterior surface 2220, and the interior surface 2210 has a bar width 2225 as measured at the widest part of the bar exterior surface 2220. In one form, the bar width 2225 is generally similar to or the same as the insertion rail width 1740 of the insertion rail 1710 in the frame 215. For each of the frame guide feet 2015, a leg extension distance 2230 is measured from the bar exterior surface 2220 of the bar 2010 to the exterior surface 2205. Between the interior surface 2210 of each of the frame guide feet 2015 and the bar exterior surface 2220, the web bar 220 has a guide foot gap 2235 with a guide foot gap width 2240. As illustrated in FIG. 23, the two frame guide feet 2015 on the same side form the frame guide width 2305 that represents the widest portion of the frame guide 2005. The ends of the frame guide feet 2015 on the same side are spaced apart by a feet tip distance 2310. In one example, the feet tip distance 2310 of the frame guide feet 2015 is less than the insertion end width 1810 of the frame 215 such that the web bar 220 is retained on the frame 215 during and after assembly. The feet tip distance 2310 between the frame guide feet 2015 also ensures that the web bar 220 is attached to the indicator section 915 at the proper orientation. The frame guide feet 2015 in the web bar 220 shown in the illustrated example have the same dimensions, but in other examples, some or all of the dimensions between two or more of the frame guide feet 2015 are different. For example, the foot guide width 2215 of the key guide foot 2217 can be smaller than the notch width 1755 of the orientation notch 1415 in the frame 215, but the rest of the frame guide feet 2015 can have a foot guide width 2215 that is wider than the notch width 1755 of the orientation notch 1415.

As illustrated in FIGS. 24 and 25, the bar 2010 has a web guide surface 2405 around which the tension web 110 slides. The bar 2010 further has a frame engagement ledge 2410 that extends below the stile engaging surface 2017 so as to engage the frame 215. The frame stile slots 2020 each has a stile slot width 2415 that is sized to receive the alignment stile 1720 or guide stile 1725 of the indicator section 915. In one form, the stile slot width 2415 of the web bar 220 is larger than the stile width 1775 of the of the frame 215 to promote sliding. The frame engagement ledge 2410 of the web bar 220 is sized to extend into the web opening 1705 of the frame 215. In the illustrated example, the frame engagement ledge 2410 has a ledge width 2420 that is smaller than the window width 1770 of the web opening 1705 so that the frame engagement ledge 2410 is able to smoothly move within the web opening 1705 of the frame 215. In one particular form, the ledge width 2420 is just slightly smaller than the web opening 1705. Altogether the stile slot width 2415 and ledge width 2420 form an inner web bar width 2502. The inner web bar width 2502 in one form is less than the stop rail

width 1805 of the frame 215, but the inner web bar width 2502 is at least slightly larger than the insertion end width 1810 of the frame 215 (FIG. 18). Once more, this dimensional relationship ensures that the web bar 220 is slid onto the frame 215 from only the end at the insertion rail 1710.

5 Looking at FIGS. 25, 26, and 27, the frame engagement ledge 2410 of the web bar 220 has a web engagement notch 2505 that is concavely or hook shaped to firmly secure the tension web 110 against the internal edge 1737 of the frame 215. The web engagement notch 2505 is able to wrap around the internal edge 1737 in the web opening 1705 which creates a tight grip with the tension web 110. As noted before, the web bar 220 in one example is
10 manufactured using a casting process that allows the web engagement notch 2505 with the hook shape to be readily formed. Each of the frame guide feet 2015 has a stile facing surface 2605 that defines a stile slot height 2610 between the frame guide feet 2015 and stile engaging surface 2017. The stile slot height 2610 is at least slightly larger than the frame thickness 1905 of the frame 215 (FIG. 19) so that the web bar 220 is able to slide along the
15 frame 215. Within the stile slot height 2610, the frame engagement ledge 2410 extends past the stile engaging surface 2017 by a ledge height 2615, and the end of the frame engagement ledge 2410 is spaced from the stile facing surface 2605 of the frame guide feet 2015 by a guide gap height 2620. In the illustrated example, the guide gap height 2620 is less than the frame thickness 1905 of the frame 215. When the web bar 220 is slid onto the insertion rail
20 1710 of the frame 215, the frame engagement ledge 2410 acts as a stop to inhibit further sliding of the web bar 220. As shown in FIG. 26, the frame guide feet 2015 is spaced from the frame engagement ledge 2410 by a feet ledge distance 2625. In one form, the feet ledge distance 2625 is at least the ledge clearance distance 1762 on the frame 215 (FIG. 17) such that the frame engagement ledge 2410 is able to be received in the web opening 1705 of the
25 frame 215 during assembly. As will be explained in further detail below, the web bar 220 then has to be rotated until the key guide foot 2217 reaches the orientation notch 1415 in the frame 215. At that point, the frame engagement ledge 2410 of the web bar 220 is positioned at the web opening 1705 in the frame 215. The web bar 220 is then able to be rotated such that the key guide foot 2217 slides through the orientation notch 1415 and hooks under the
30 frame 215. From there, the web bar 220 continues to slide along the frame 215 during assembly with the web bar 220 slidably secured to the frame 215.

As mentioned before, the indicator 225 includes the longitudinal tension indicator 315 located between the lateral tension indicators 310. Referring to FIGS. 28, 29, 30, and 31, the

indicator 225 further includes an indicator body 2805 that extends between the lateral tension indicators 310. An indicator guide flange 2810 extends from the indicator body 2805 generally parallel to the longitudinal tension indicator 315. As shown, one or more indicator connection legs 2815 are angled from the lateral tension indicators 310 towards the longitudinal tension indicator 315 so as to connect the lateral tension indicators 310 to the longitudinal tension indicator 315. The longitudinal tension indicator 315 extends past the indicator guide flange 2810 such that the indicator guide flange 2810 is recessed relative to the longitudinal tension indicator 315. With the indicator guide flange 2810 recessed, the indicator guide flange 2810 is able to be inserted through the web opening 1705 in the frame 215. At the same time, the lateral tension indicators 310 and longitudinal tension indicator 315 help to retain the indicator 225 at the proper position relative to the frame 215 during assembly. A web guide channel 2820 through which the fixed web 115 extends is formed between longitudinal tension indicator 315 and the indicator body 2805 as well as the indicator guide flange 2810. The lateral tension indicators 310 have one or more web bar spring seat cavities 2825 with web bar spring pins 2830 to which the web bar springs 230 are secured. The indicator body 2805 has one or more indicator spring seat cavities 2835 with indicator spring pins 2840 to which the indicator springs 235 are secured. The indicator guide flange 2810 has one or more indicator spring grooves 2845 that are aligned with the indicator spring seat cavities 2835 to retain the indicator springs 235.

As noted before, the indicator guide flange 2810 is recessed relative to the longitudinal tension indicator 315 such that the indicator guide flange 2810 is able to be fitted through the web opening 1705 during assembly while at the same time the longitudinal tension indicator 315 is long enough to retain the indicator 225 when the web bar 220 is installed. Looking at FIGS. 32, 33, 34, and 35, the indicator guide flange 2810 is recessed relative to the longitudinal tension indicator 315 by a recessed distance 3305. The lateral tension indicators 310 are raised from the indicator guide flange 2810 by a lateral indicator height 3405, as is indicated in FIG. 34. The indicator body 2805 in FIG. 35 is raised from the indicator guide flange 2810 by a frame edge engagement height 3505. The lateral indicator height 3405 of the lateral tension indicators 310 and the frame edge engagement height 3505 of the indicator body 2805 are generally the same and generally correspond to the frame thickness 1905 of the frame 215 (FIG. 19). With such dimensions, the indicator spring seat cavities 2835 are generally aligned with the internal edge 1737 of the frame 215 (FIG. 17)

such that the indicator springs 235 are positioned for compression between the indicator body 2805 and the internal edge 1737 of the frame 215.

A technique for assembling the tilt-lock adjuster system 100 will initially be described with reference to FIGS. 36, 37, 38, 39, and 40. As described before, the frame 215 and web bar 220 utilize a unique keying arrangement that ensures proper assembly of the tilt-lock adjuster 105. During assembly, the frame orientation guide 1405 on the frame 215 and the web bar orientation guide 1410 on the web bar 220 (FIG. 14) are positioned on the same side so that the frame 215 and web bar 220 are properly aligned. As depicted by arrow 3605 in FIG. 36, the web bar 220 is then slid onto the insertion rail 1710 of the frame 215 with the two opposing frame guide feet 2015 engaged underneath the frame 215. As mentioned before, the frame 215 and web bar 220 are dimensioned so that the web bar 220 can be slid or attached to the frame 215 in only one way. Referring to FIGS. 26 and 36, the guide gap height 2620 of the frame engagement ledge 2410 is smaller than the frame thickness 1905 (FIG. 19) of the frame 215 such that as the web bar 220 continues to slide onto the frame 215, and the frame engagement ledge 2410 eventually hits the insertion rail 1710 so that the frame engagement ledge 2410 prevents the web bar 220 from completely sliding onto the frame 215. The assembler or automated system then has to rotate the web bar 220 such that the key guide foot 2217 rides on top of the frame 215. Once the key guide foot 2217 reaches the orientation notch 1415, as is indicated by the dashed lines in FIG. 37, the frame engagement ledge 2410 has cleared the insertion rail 1710 such that the frame engagement ledge 2410 is then able to be received in the web opening 1705. Looking at FIGS. 37 and 38, the key guide foot 2217 is inserted through the orientation notch 1415 in the direction as indicated by arrow 3705. As mentioned before, the feet ledge distance 2625 of the key guide foot 2217 is greater than or equal to the ledge clearance distance 1762 on the frame 215 (FIG. 17) such that the frame engagement ledge 2410 is able to be received in the web opening 1705 of the frame 215 during assembly.

Once the key guide foot 2217 is inserted through the orientation notch 1415 in the frame 215, the web bar 220 slides along the alignment stile 1720 and guide stile 1725 in the direction indicated by arrow 3605 in FIG. 39 towards the stop rail 1715. The web engagement notch 2505 of the frame engagement ledge 2410 properly faces the internal edge 1737 at the stop rail 1715. As mentioned before, the curved or hook-shape of the web engagement notch 2505 ensures a firmer or stronger grip of the tension web 110 sandwiched between the frame 215 and web bar 220 when tightened (see e.g., FIG. 7). The indicator

guide flange 2810 of the indicator 225 is inserted through the web opening 1705 in the frame 215 and slides towards the insertion rail 1710 of the frame 215 in the manner shown in FIG. 40. As noted before with reference to FIG. 34, the indicator guide flange 2810 is recessed relative to the longitudinal tension indicator 315 by the recessed distance 3305 such that the indicator guide flange 2810 is able to be fitted through the web opening 1705 during assembly while at the same time the longitudinal tension indicator 315 is long enough to retain the indicator 225 when the web bar 220 is installed. The indicator guide flange 2810 is then able to clip underneath the insertion rail 1710 of the frame 215 (see e.g., FIG 16). The lateral tension indicators 310 of the indicator 225 are able to slide along the alignment stile 1720 and guide stile 1725 of the frame 215. As discussed before with respect to FIGS. 34 and 35, the lateral tension indicators 310 are raised from the indicator guide flange 2810 by the lateral indicator height 3405. The indicator body 2805 in FIG. 35 is raised from the indicator guide flange 2810 by the frame edge engagement height 3505. The lateral indicator height 3405 of the lateral tension indicators 310 and the frame edge engagement height 3505 of the indicator body 2805 are generally the same and generally correspond to the frame thickness 1905 of the frame 215 (FIG. 19). With such dimensions, the indicator spring seat cavities 2835 are generally aligned with the internal edge 1737 of the frame 215 (FIG. 17) such that the indicator springs 235 are positioned for compression between the indicator body 2805 and the internal edge 1737 of the frame 215. In one example, the web bar springs 230 and indicator springs 235 are already attached to the indicator 225 before being secured to the frame 215. Alternatively, some or all of the web bar springs 230 and/or indicator springs 235 are secured to the indicator 225 after the indicator 225 is secured to the frame 215.

The cover 205 is then secured to the frame 215 by clipping the frame clips 920 of the cover 205 (FIG. 9) underneath the frame 215. In one variation, the tension web 110 is looped around the web bar 220, and the fixed web 115 is looped around indicator 225 in the manner as depicted in FIG. 7. This attachment of the tension web 110 and fixed web 115 to the adjuster indicator assembly 210 occurs in one form after the cover 205 is attached. In other examples, one or both webs are secured to the adjuster indicator assembly 210 before the cover 205 is secured to the frame 215.

FIGS. 41 and 42 show one example of how the frame 215 prevents the web bar 220 from being installed in the wrong orientation. Again, to ensure a tight vice grip of the tension web 110 between the frame 215 and web bar 220 during tightening, the web engagement notch 2505 should face the internal edge 1737 at the stop rail 1715. In the example shown in

FIG. 41, the frame guide feet 2015 of the web bar 220 are slid underneath the frame 215 in the direction indicated by arrow 4105 until the frame engagement ledge 2410 hits the insertion rail 1710 of the frame 215. As indicated by arrow 4205 in FIG. 42, the web bar 220 is then rotated. The frame guide feet 2015 of the web bar 220 slides on top of the indicator section 915. However, without the orientation notch 1415, the frame guide feet 2015 of the web bar 220 are unable to hook underneath the frame 215. As should be recognized, this improper orientation would then be quite evident to the assembler and/or automated vision system. It also would be quite difficult to secure the frame guide feet 2015 to the frame 215.

Glossary of Terms

The language used in the claims and specification is to only have its plain and ordinary meaning, except as explicitly defined below. The words in these definitions are to only have their plain and ordinary meaning. Such plain and ordinary meaning is inclusive of all consistent dictionary definitions from the most recently published Webster's dictionaries and Random House dictionaries. As used in the specification and claims, the following definitions apply to these terms and common variations thereof identified below.

"Acute Angle" generally refers to an angle smaller than a right angle or less than 90 degrees.

"Asymmetric" generally refers to an object not being identical on both sides of a central line.

"Concave" generally refers to a surface that is hollowed or rounded inward in at least one dimension like the inside of a bowl or a groove.

"Frame" generally refers to a structure that forms part of an object and gives strength and/or shape to the object.

"Lateral" generally refers to being situated on, directed toward, or coming from the side.

"Longitudinal" generally relates to length or lengthwise dimension of an object, rather than across.

"Notch" generally refers to an indentation, cut, groove, channel, and/or incision on an edge or surface. In some non-limiting examples the notch includes a V-shaped or U-shaped indentation carved, scratched, etched, stamped, and/or otherwise formed in the edge or surface. The notch can have a uniform shape or a non-uniform shape.

"Pushbutton Adjuster" generally refers to a webbing or strap adjustment mechanism that releases the mechanism's hold on the webbing for the purpose of releasing tension and/or lengthening the webbing when a button is depressed. Typically, but not always, the pushbutton adjuster does not inhibit the webbing from being shortened when the free end of the webbing is pulled.

"Seat Belt", "Safety Belt", or "Vehicle Belt" generally refers to an arrangement of webs and other devices designed to restrain or otherwise hold a person or other object steady such as in a boat, vehicle, aircraft, and/or spacecraft. For example, the seat belt is designed to secure an occupant of a vehicle against harmful movement that may result during a collision or a sudden stop. By way of non-limiting examples, the seat belt can include webbing, buckles, latch plates, and/or length-adjustment mechanisms, such as a retractor, installed in the vehicle that is used to restrain an occupant or a child restraint system. The seat belt for instance can include a lap belt only, a combination lap-shoulder belt, a separate lap belt, a separate shoulder belt, and/or a knee bolster.

"Slide Adjuster" generally refers to hardware used to lock webbing at a fixed length using a single plate or at least a pair of plates with slots through which the webbing is threaded in a prescribed manner. By way of non-limiting examples, the slide adjuster may use one slide with three slots or two slides with two slots each. Typically, but not always, the webbing must be detached and the webbing loops manually loosened to either shorten or lengthen the webbing.

"Spring" generally refers to an elastic object that stores mechanical energy. The spring can include a resilient device that can be pressed, pulled, and/or twisted but returns to its former shape when released. The spring can be made from resilient or elastic material such as metal and/or plastic. The spring can counter or resist loads in many forms and apply force at constant or variable levels. For example, the spring can include a tension spring, compression spring, torsion spring, constant spring, and/or variable spring. The spring can take many forms such as by being a flat spring, a machined spring, and/or a serpentine spring. By way of nonlimiting examples, the springs can include various coil springs, pocket springs, Bonnell coils, offset coils, continuous coils, cantilever springs, volute springs, hairsprings, leaf springs, V-springs, gas springs, leaf springs, torsion springs, rubber bands, spring washers, and/or wave springs, to name just a few.

"Tilt-Lock Adjuster" generally refers to a webbing or strap adjustment mechanism that releases the mechanism's hold on the webbing for the purpose of releasing tension and/or

lengthening the webbing when the mechanism is lifted and/or held at an angle that is generally transverse to the general longitudinal direction of the webbing. Typically, but not always, the tilt-lock adjuster does not inhibit the overall length of the webbing from being shortened when the free end of the webbing is pulled.

5 "Web" or "Webbing" generally refers to a strap made of a network of thread, strings, cords, wires, and/or other materials designed to restrain or otherwise hold a person or other object steady such as in a boat, vehicle, aircraft, and/or spacecraft. By way of non-limiting examples, the web can be incorporated into a seat belt, a child booster seat, and/or car seat.

"Window" generally refers to an opening or generally transparent panel in a wall of
10 an object that facilitates interior viewing of the object.

It should be noted that the singular forms "a," "an," "the," and the like as used in the description and/or the claims include the plural forms unless expressly discussed otherwise. For example, if the specification and/or claims refer to "a device" or "the device", it includes one or more of such devices.

15 It should be noted that directional terms, such as "up," "down," "top," "bottom," "lateral," "longitudinal," "radial," "circumferential," "horizontal," "vertical," etc., are used herein solely for the convenience of the reader in order to aid in the reader's understanding of the illustrated embodiments, and it is not the intent that the use of these directional terms in any manner limit the described, illustrated, and/or claimed features to a specific direction
20 and/or orientation.

While the invention has been illustrated and described in detail in the drawings and foregoing description, the same is to be considered as illustrative and not restrictive in character, it being understood that only the preferred embodiment has been shown and described and that all changes, equivalents, and modifications that come within the spirit of
25 the inventions defined by the following claims are desired to be protected. All publications, patents, and patent applications cited in this specification are herein incorporated by reference as if each individual publication, patent, or patent application were specifically and individually indicated to be incorporated by reference and set forth in its entirety herein.

Reference Numbers

100 tilt-lock adjuster system	825 indicator notch
105 tilt-lock adjuster	905 ribs
110 tension web	910 tension web section
115 fixed web	915 indicator section
120 belt adjuster end	920 frame clips
205 cover	925 frame standoffs
210 adjuster indicator assembly	930 frame notches
215 frame	1205 trailing jamb edge
220 web bar	1210 leading jamb edge
225 indicator	1215 head jamb edge
230 web bar springs	1220 sill edge
235 indicator springs	1305 interior surface
305 lateral windows	1310 exterior surface
310 lateral tension indicators	1315 trailing jamb angle
315 longitudinal tension indicator	1405 frame orientation guide
605 longitudinal axis	1410 web bar orientation guide
610 lateral axis	1415 orientation notch
705 grip cavity	1705 web opening
707 arrow	1710 insertion rail
710 web bar cavity	1715 stop rail
715 indicator cavity	1720 alignment stile
720 stop member	1725 guide stile
725 arrow	1730 stop flanges
730 arrow	1735 peripheral edge
800 cover body	1737 internal edge
805 grip end	1740 insertion rail width
810 indicator end	1745 alignment tab
815 lateral sidewalls	1750 tab width
820 grip protrusion	1755 notch width
1760 notch window distance	2420 ledge width
1762 ledge clearance distance	2502 inner web bar width

Reference Numbers

1765 stop window distance	2505 web engagement notch
1770 window width	2605 stile facing surface
1775 stile width	2610 stile slot height
1805 stop rail width	2615 ledge height
1810 insertion end width	2620 guide gap height
1905 frame thickness	2625 feet ledge distance
2005 frame guide	2805 indicator body
2010 bar	2810 indicator guide flange
2012 frame guide legs	2815 indicator connection legs
2015 frame guide feet	2820 web guide channel
2017 stile engaging surface	2825 web bar spring seat cavities
2020 frame stile slots	2830 web bar spring pins
2025 spring seat cavities	2835 indicator spring seat cavities
2205 exterior surface	2840 indicator spring pins
2210 interior surface	2845 indicator spring grooves
2215 foot guide width	3305 recessed distance
2217 key guide foot	3405 lateral indicator height
2220 bar exterior surface	3505 frame edge engagement height
2225 bar width	3605 arrow
2230 leg extension distance	3705 arrow
2235 guide foot gap	4105 arrow
2240 guide foot gap width	4205 arrow
2305 frame guide width	
2310 feet tip distance	
2405 web guide surface	
2410 frame engagement ledge	
2415 stile slot width	

CLAIMS

What is claimed is:

- 5 1. A tilt-lock adjuster system, comprising:
a tilt-lock adjuster including
an indicator configured to indicate when proper tension is applied to webbing secured
by the tilt-lock adjuster.
- 10 2. The system of claim 1, wherein the tilt-lock adjuster includes:
a frame to which the indicator is slidably coupled; and
a web bar slidably coupled to the frame.
- 15 3. The system of claim 2, wherein the web bar is asymmetric for one way
assembly with the frame.
4. The system of claim 3, wherein the web bar has a web engagement notch that
is concave for enhancing locking of the webbing to the frame.
- 20 5. The system of claim 4, wherein the web bar has a frame guide slidably
engaged to the frame.
6. The system of claim 5, wherein the web bar has a frame engagement ledge
that defines a guide gap height that is smaller than a frame thickness of the frame.
- 25 7. The system of claim 6, wherein the frame defines a web opening in which the
frame engagement ledge extends.
8. The system of claim 7, wherein:
30 the frame guide of the web bar includes a key guide foot; and
the frame has an orientation notch configured to receive the key guide foot of the web
bar.

9. The system of claim 2, wherein the web bar and the indicator are configured to move independently of one another.

10. The system of claim 9, wherein the tilt-lock adjuster includes one or more web bar springs positioned between the web bar and the indicator.

11. The system of claim 1, wherein the indicator includes:
one or more lateral tension indicators; and
a longitudinal tension indicator.

10

12. The system of claim 11, wherein the tilt-lock adjuster includes a cover having one or more lateral windows in which the lateral tension indicators are visible when the proper tension is applied to the webbing.

13. The system of claim 11, wherein the lateral windows have one or more edges that are angled at an acute angle to enhance visibility of the lateral tension indicators.

14. The system of claim 11, wherein the indicator includes an indicator guide flange that is recessed relative to the longitudinal tension indicator.

20

15. The system of claim 1, wherein the indicator includes one or more indicator springs to bias the indicator in a retracted position.

16. The system of claim 15, wherein the indicator includes one or more indicator spring seat cavities where the indicator springs are secured.

17. The system of claim 1, wherein the tilt-lock adjuster includes a frame with a frame orientation guide and a web bar with a web bar orientation guide.

18. The system of claim 1, wherein the tilt-lock adjuster includes a cover with one or more ribs defining an indicator cavity in which the indicator is retained.

30

19. A method of assembling a tilt-lock adjuster system, comprising:
sliding a web bar at least partially onto a frame in a first direction;
rotating the web bar relative to the frame to allow continued sliding of the web bar
onto the frame in the first direction; and
5 inserting a key guide foot of the web bar through an orientation notch in the frame.

20. The method of claim 19, further comprising:
aligning a web bar orientation guide on the web bar with a frame orientation guide on
the frame before said sliding.

10

21. The method of claim 19, further comprising:
casting the web bar to form a web engagement notch.

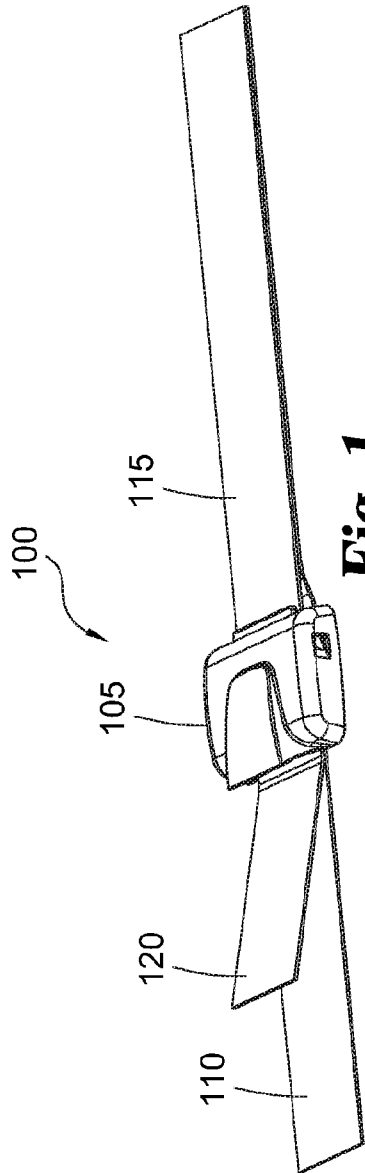

Fig. 1

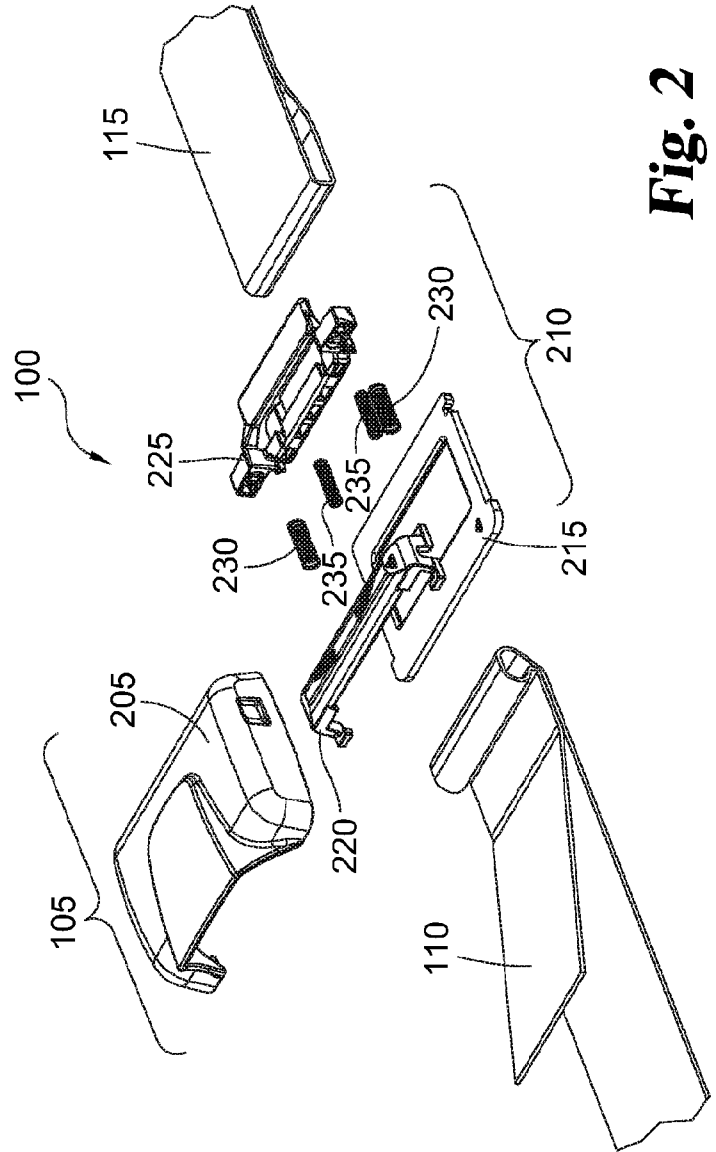

Fig. 2

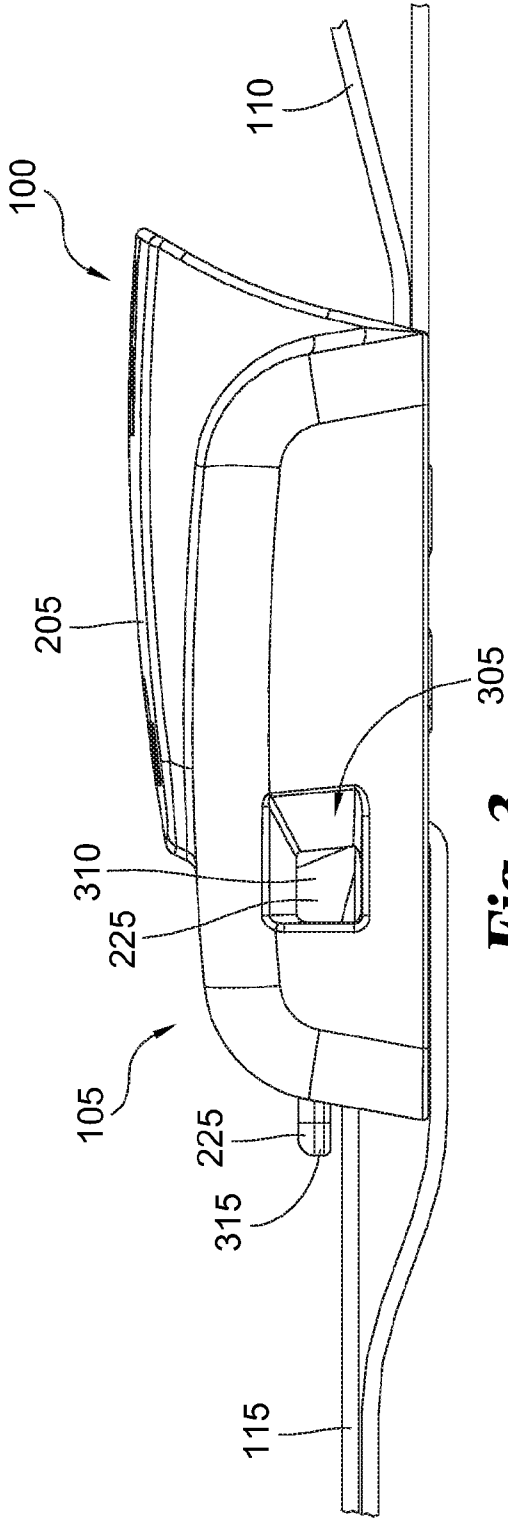

Fig. 3

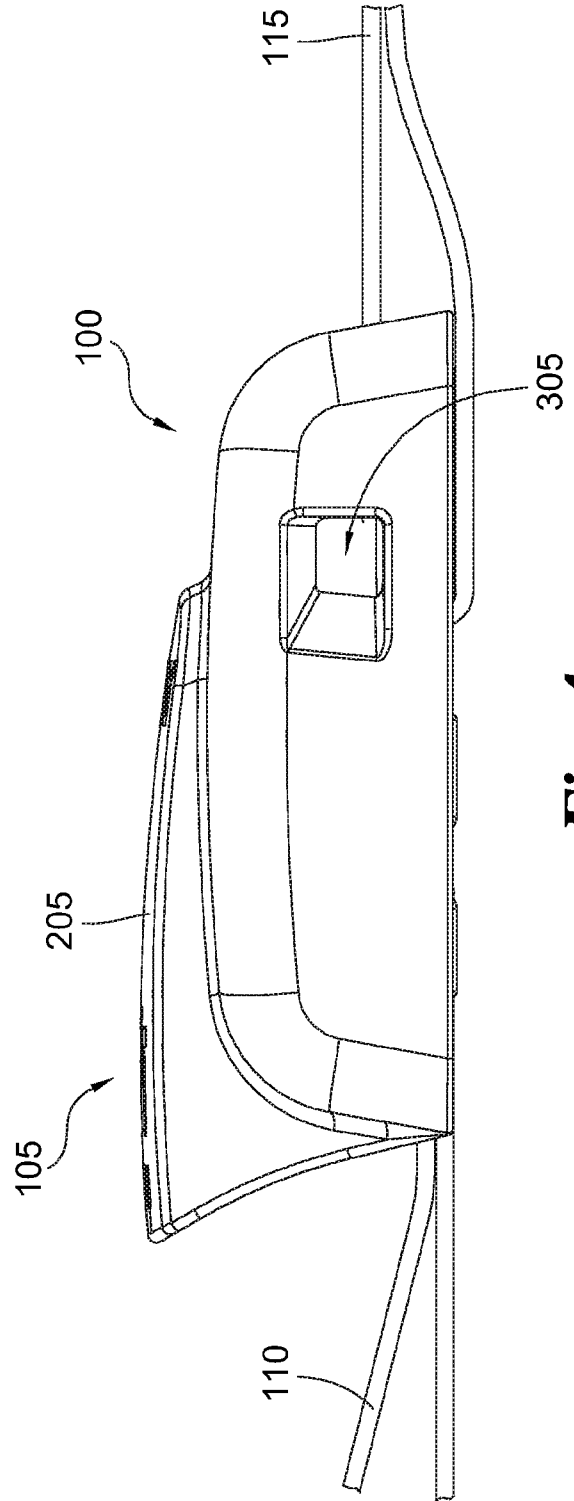

Fig. 4

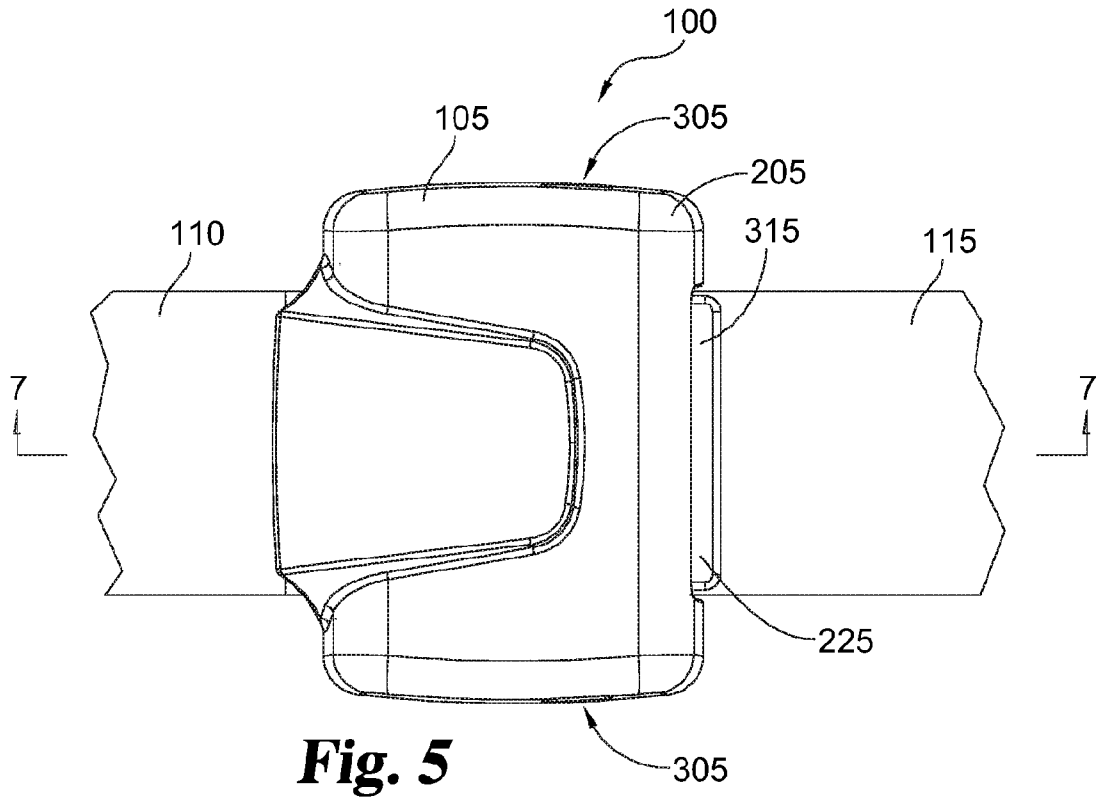

Fig. 5

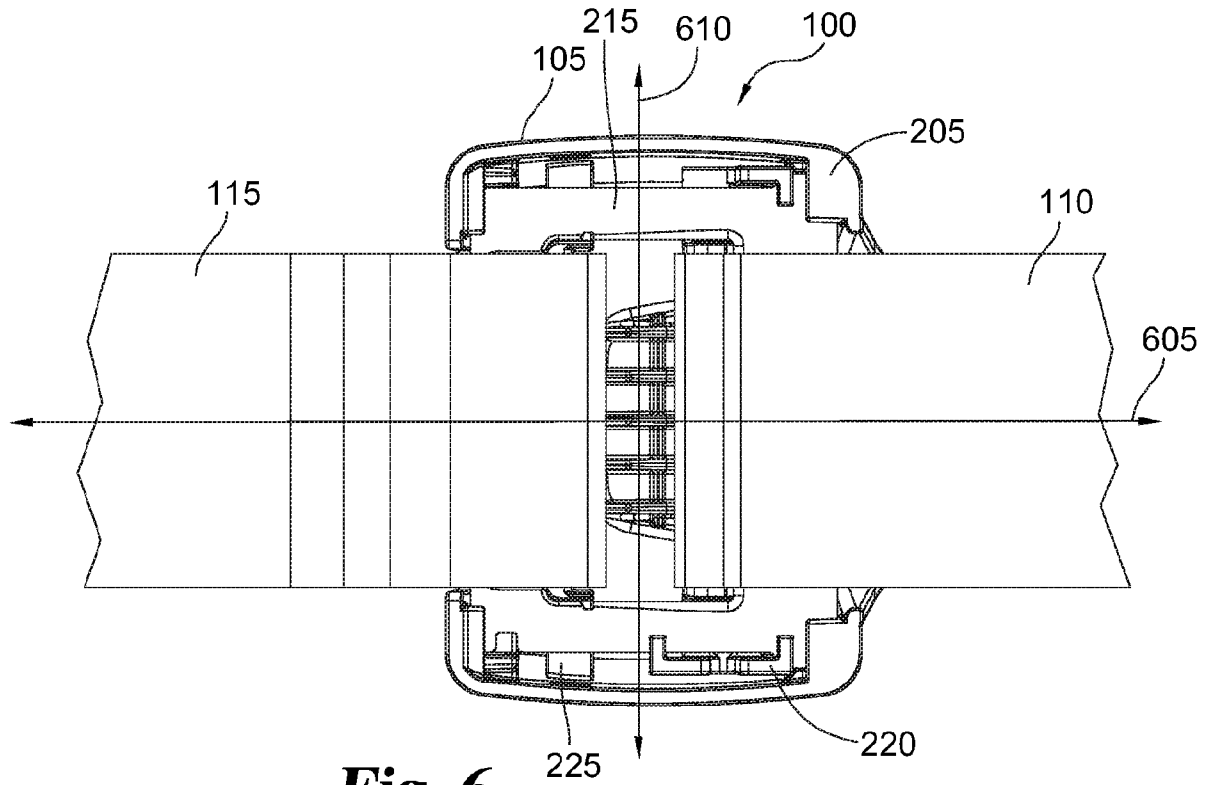

Fig. 6

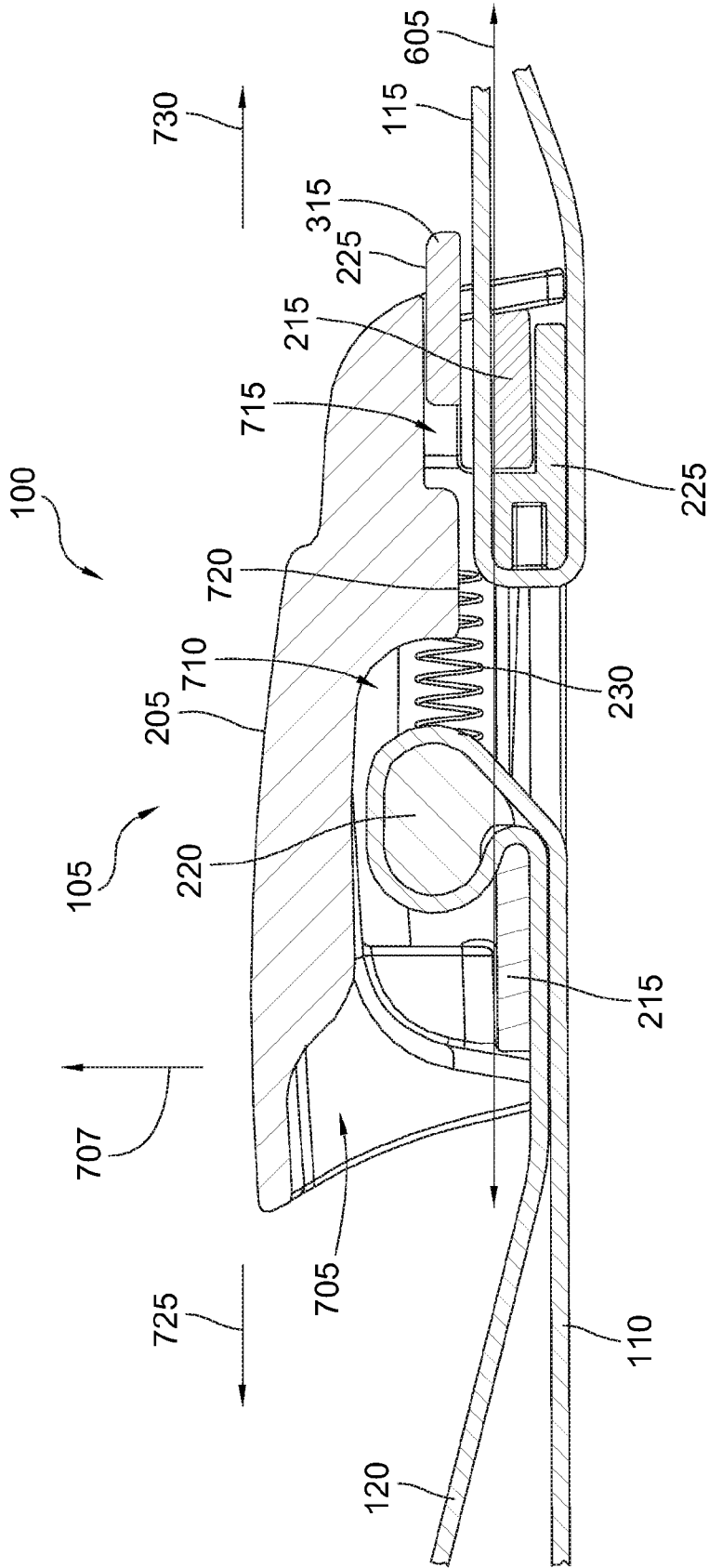

Fig. 7

5/22

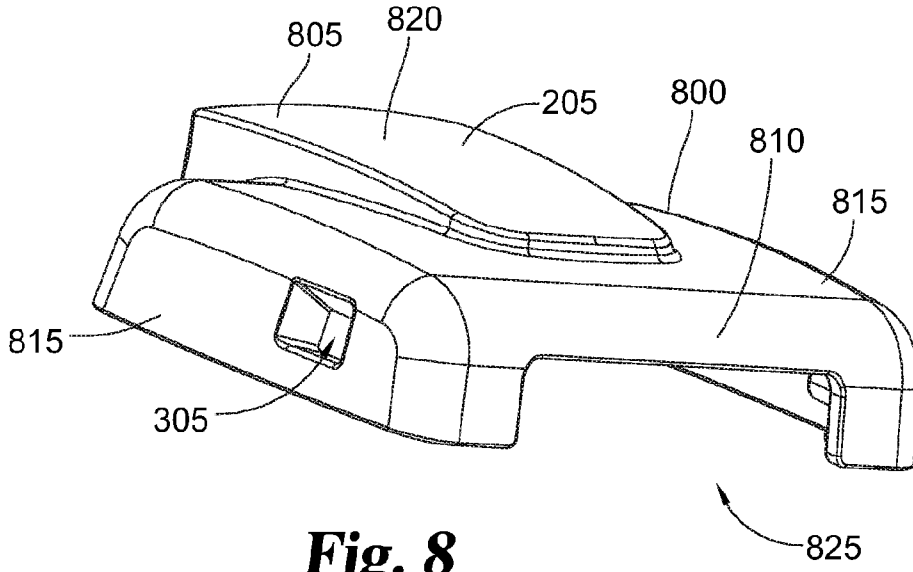

Fig. 8

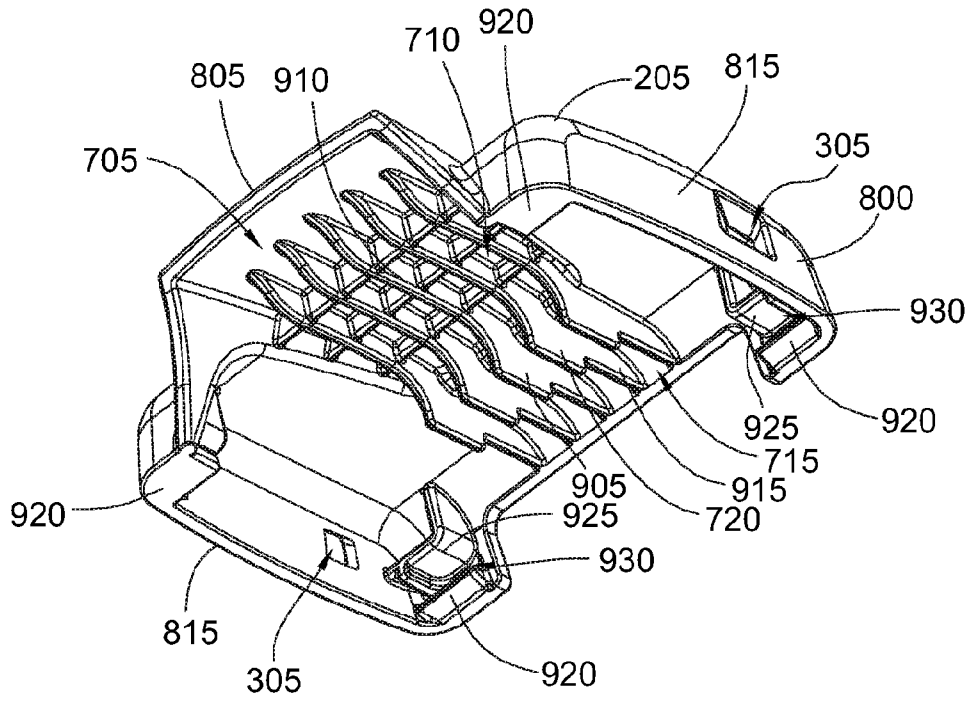

Fig. 9

6/22

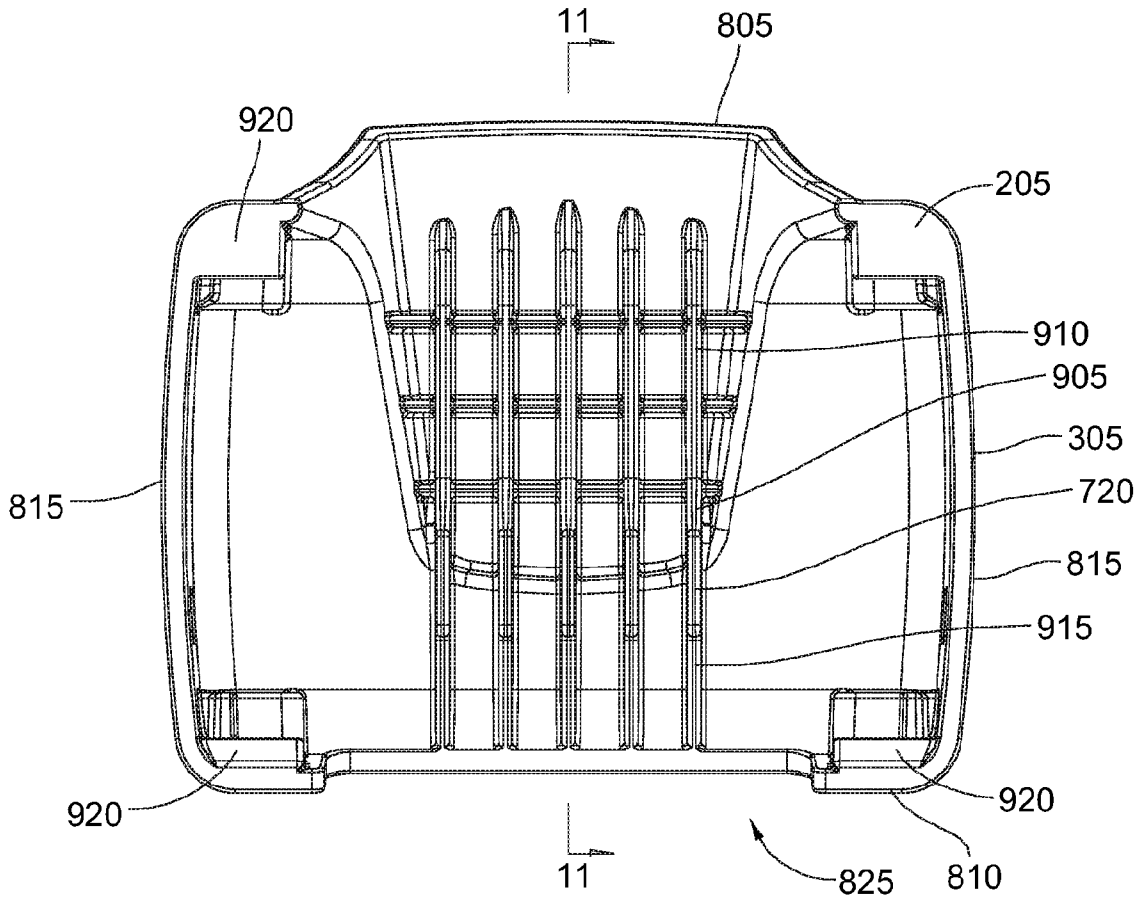

Fig. 10

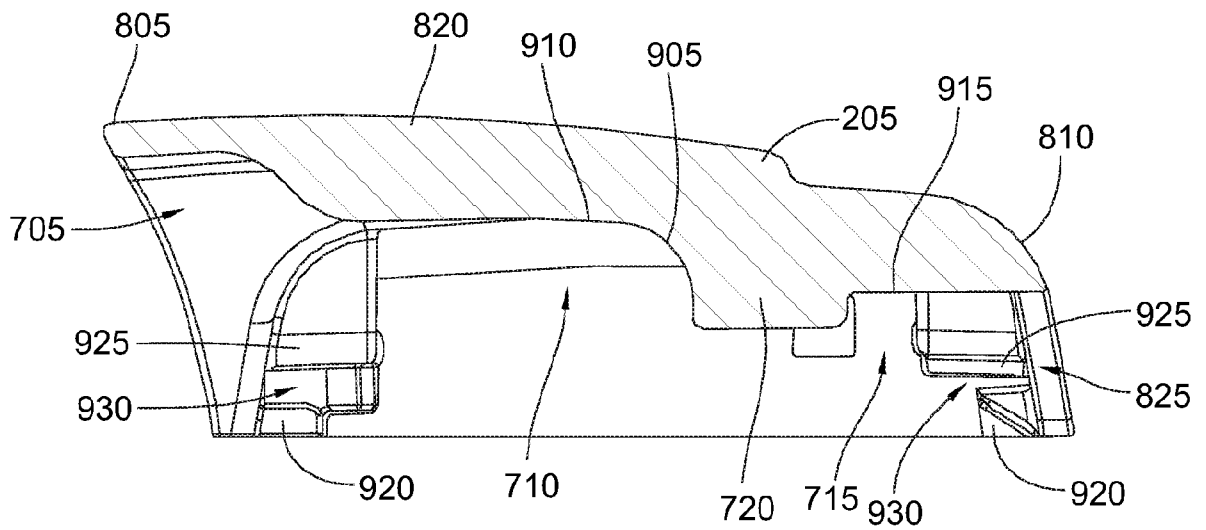

Fig. 11

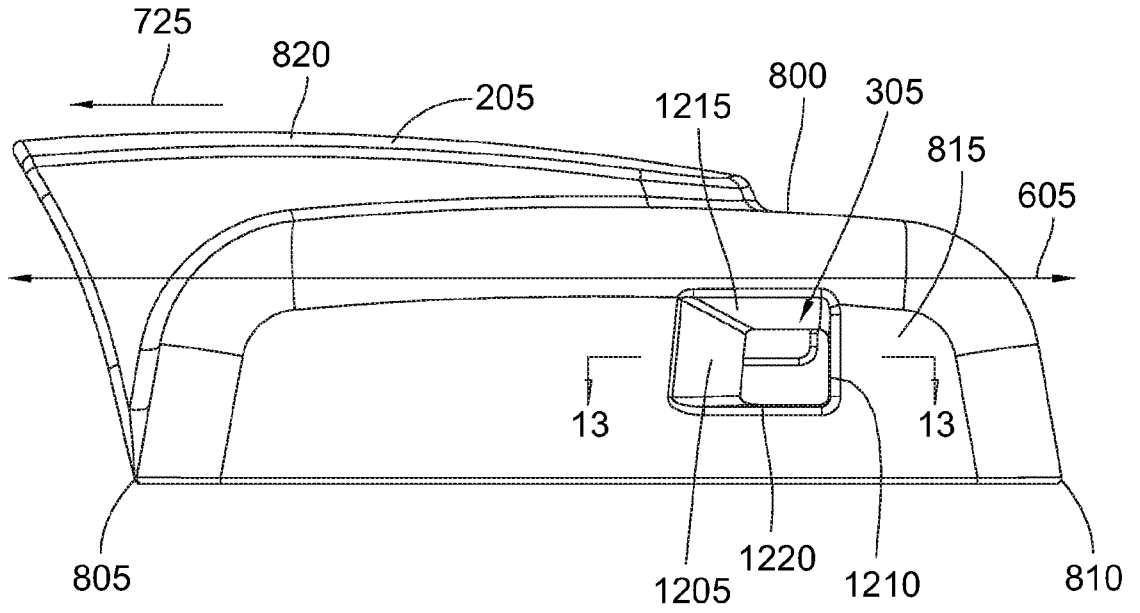

Fig. 12

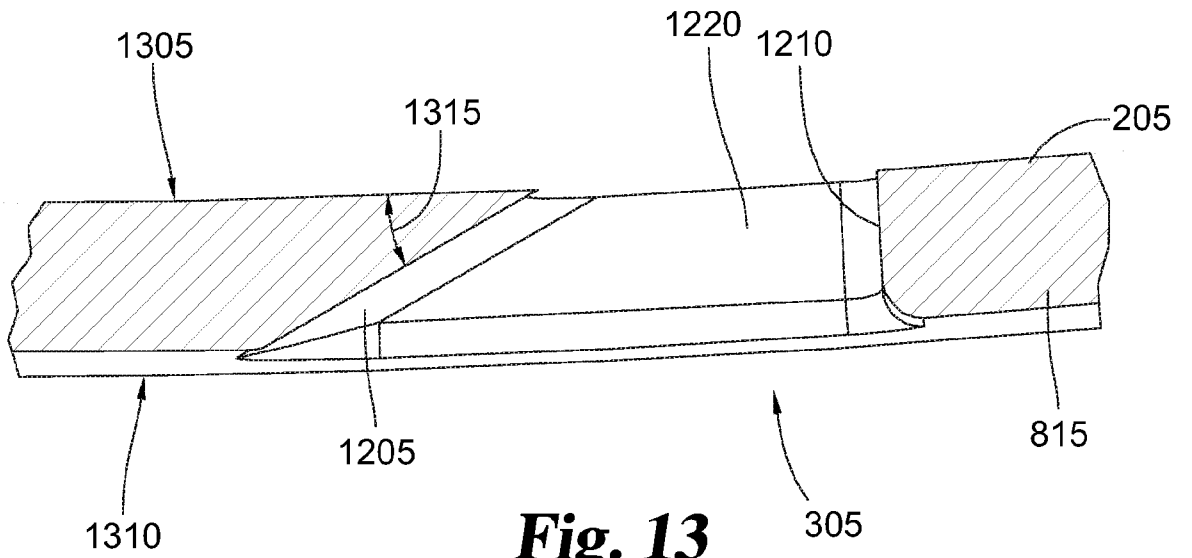

Fig. 13

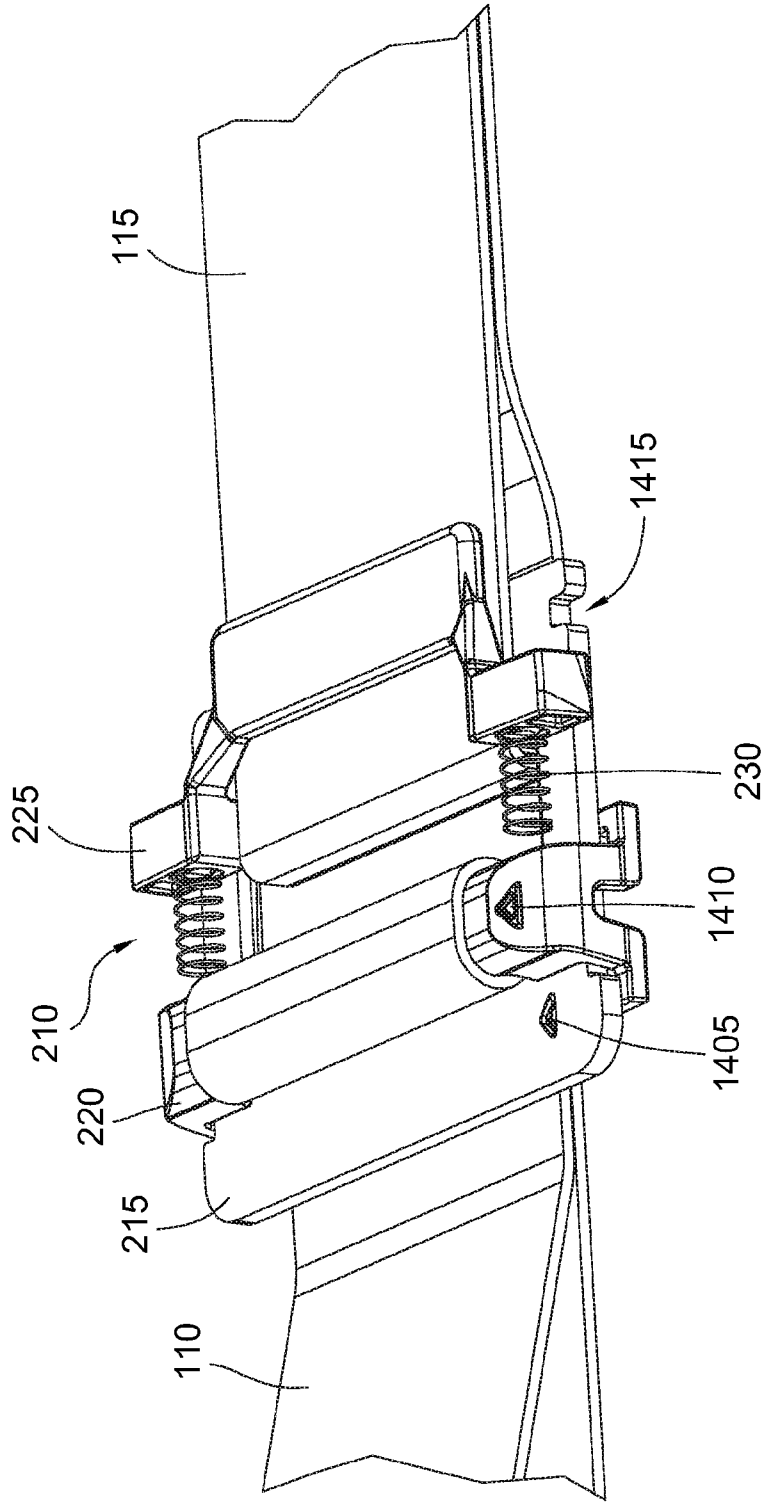

Fig. 14

9/22

Fig. 15

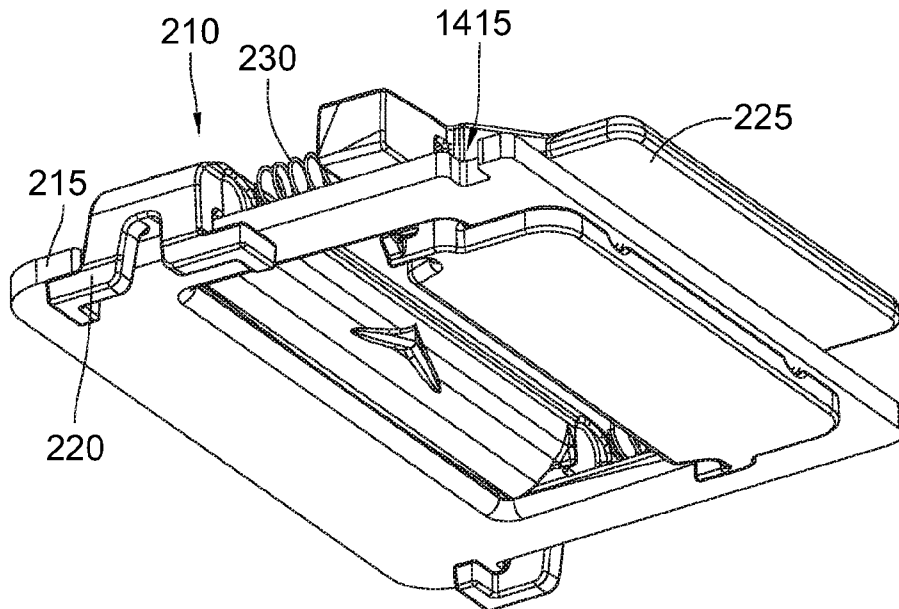
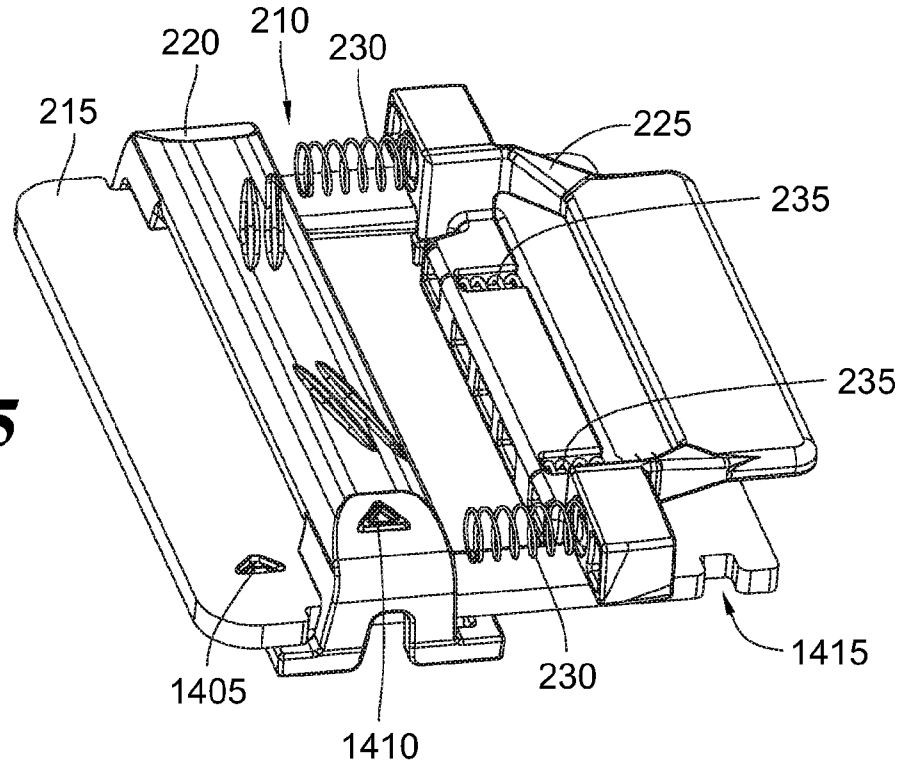

Fig. 16

11/22

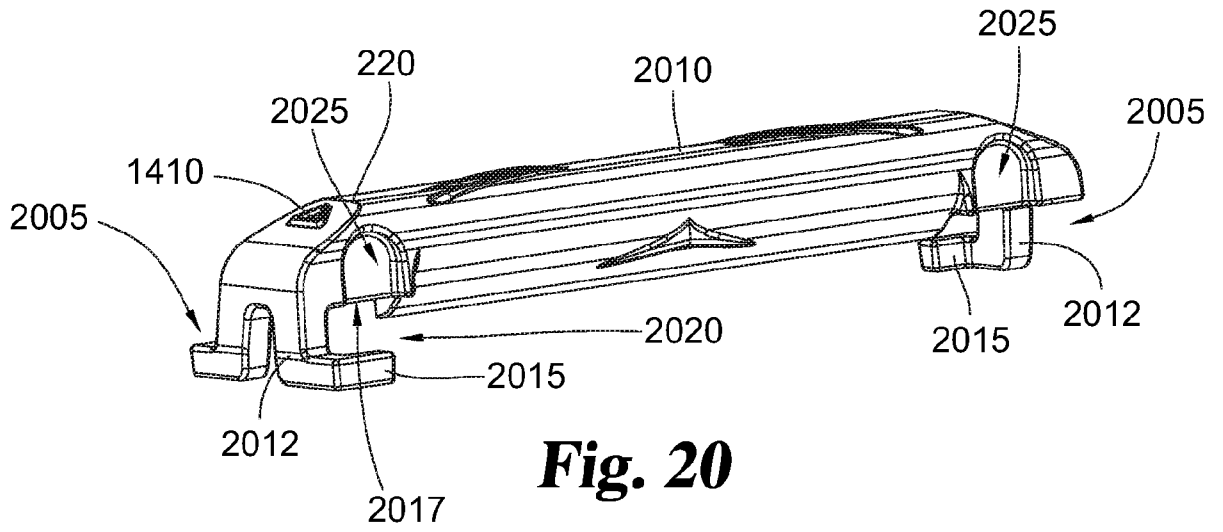

Fig. 20

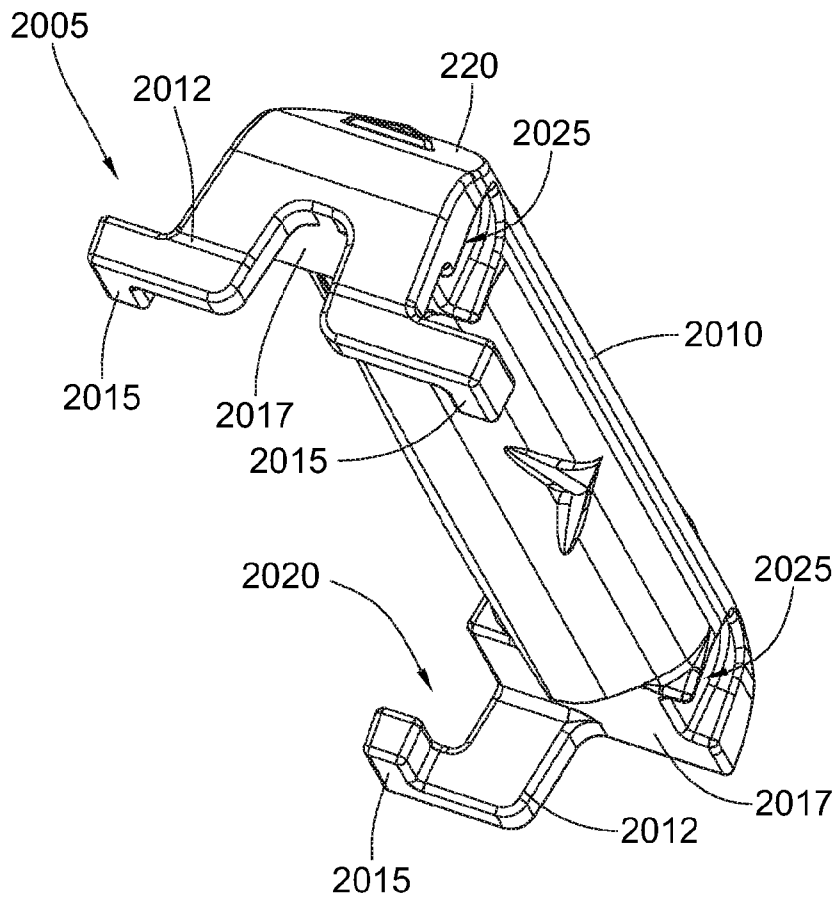
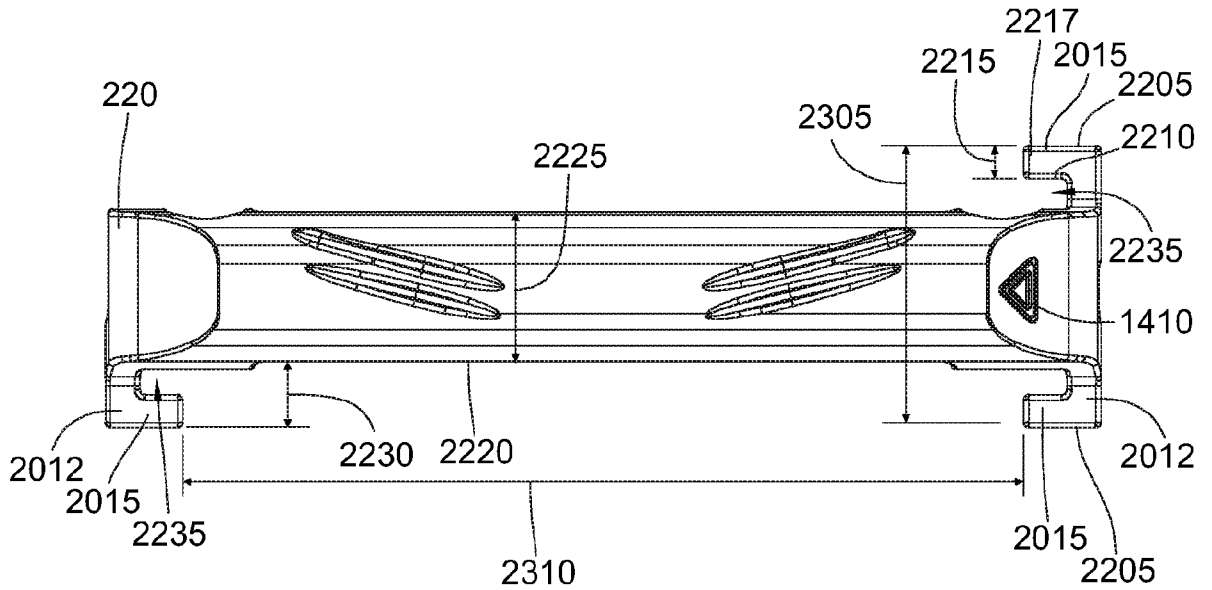
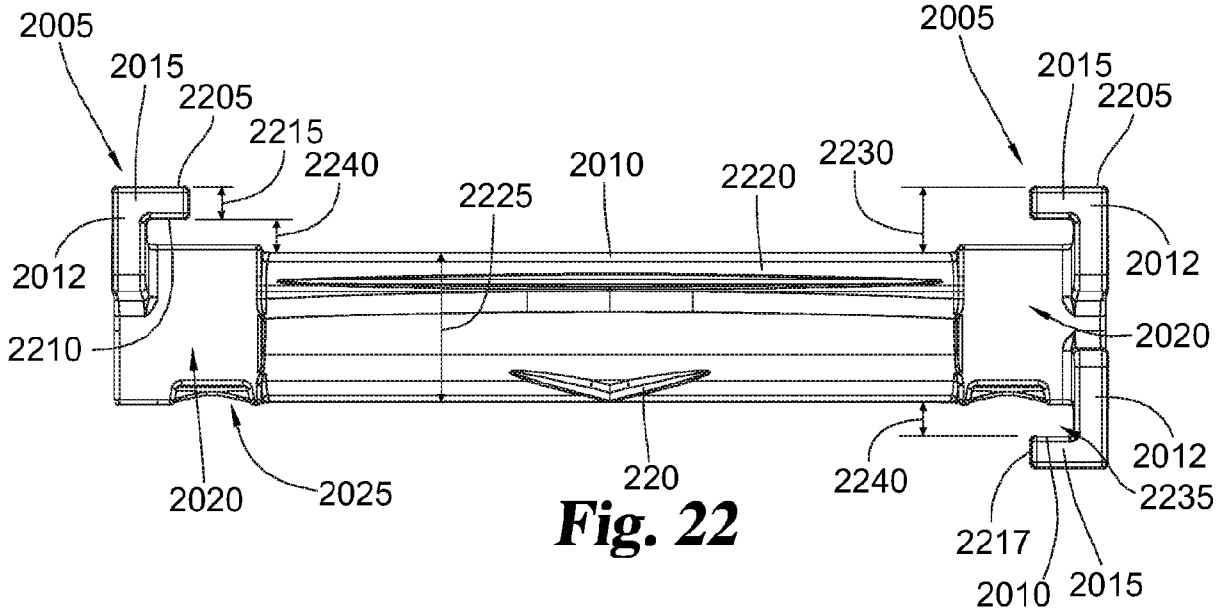

Fig. 21

12/22



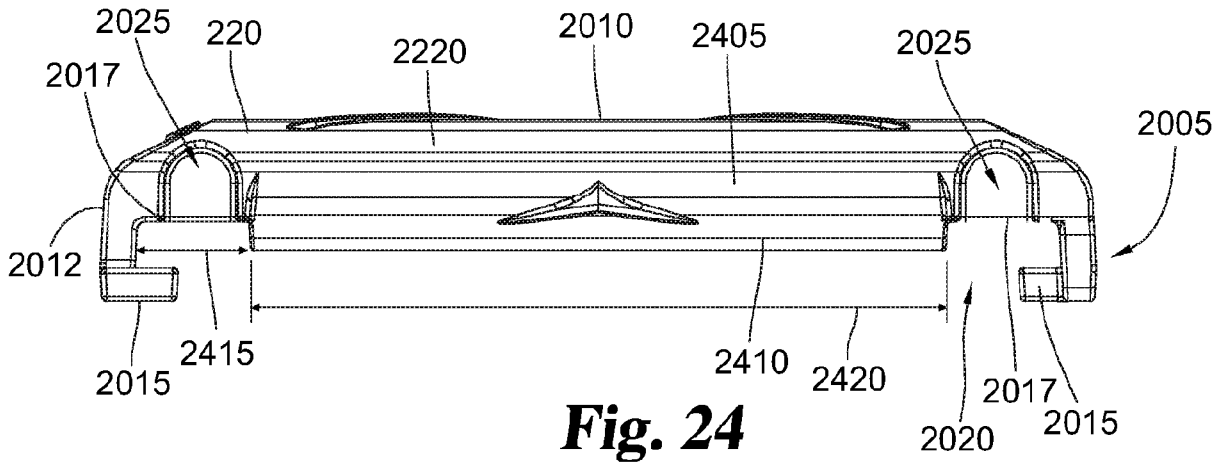

Fig. 24

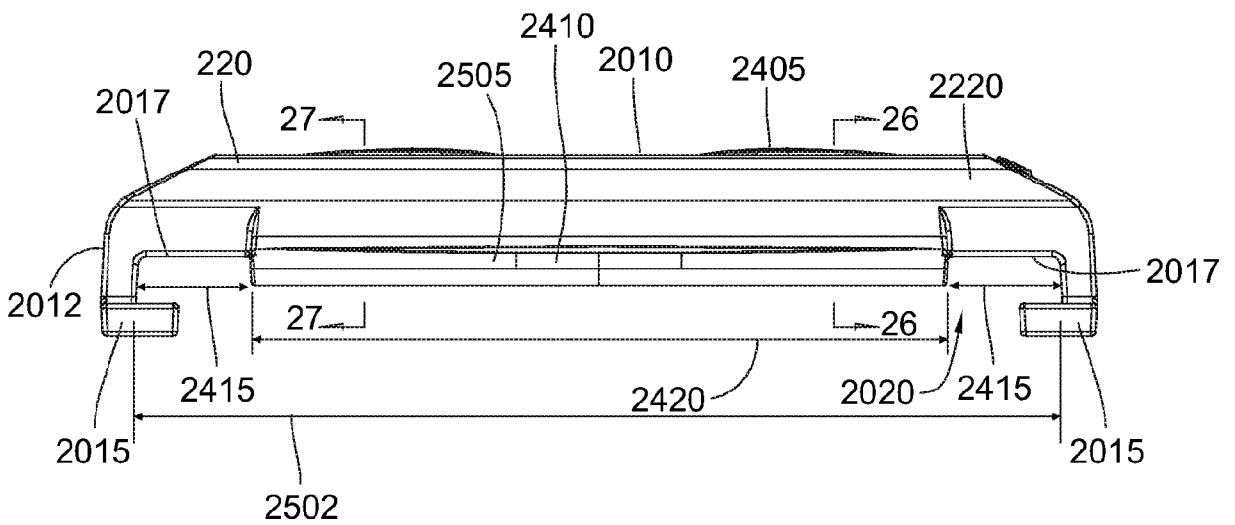

Fig. 25

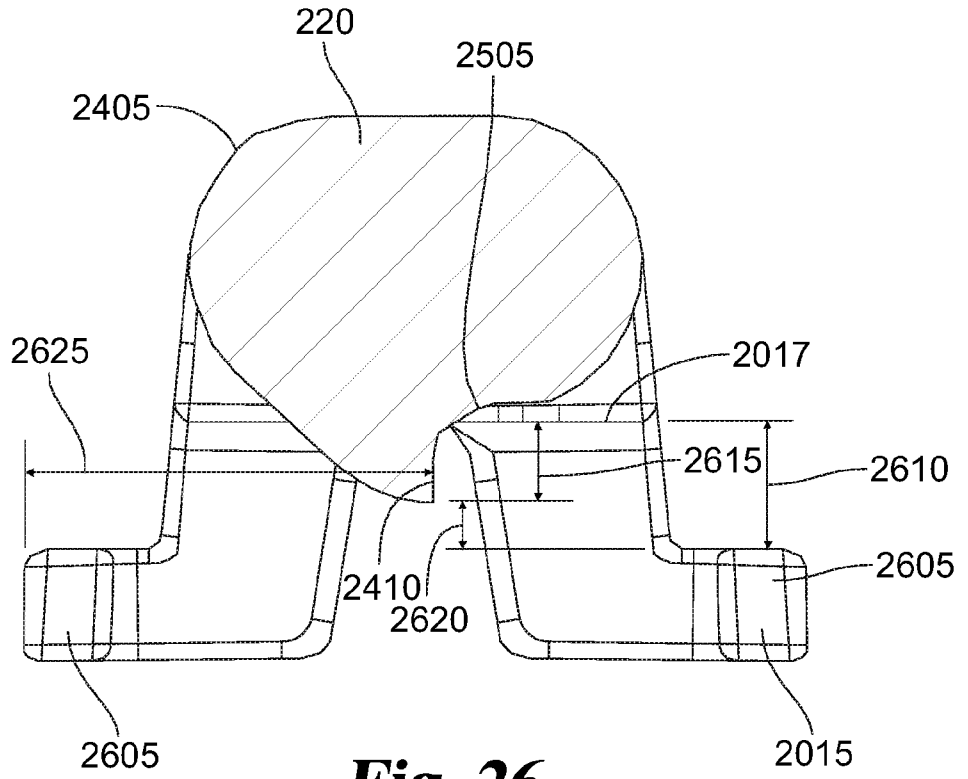

Fig. 26

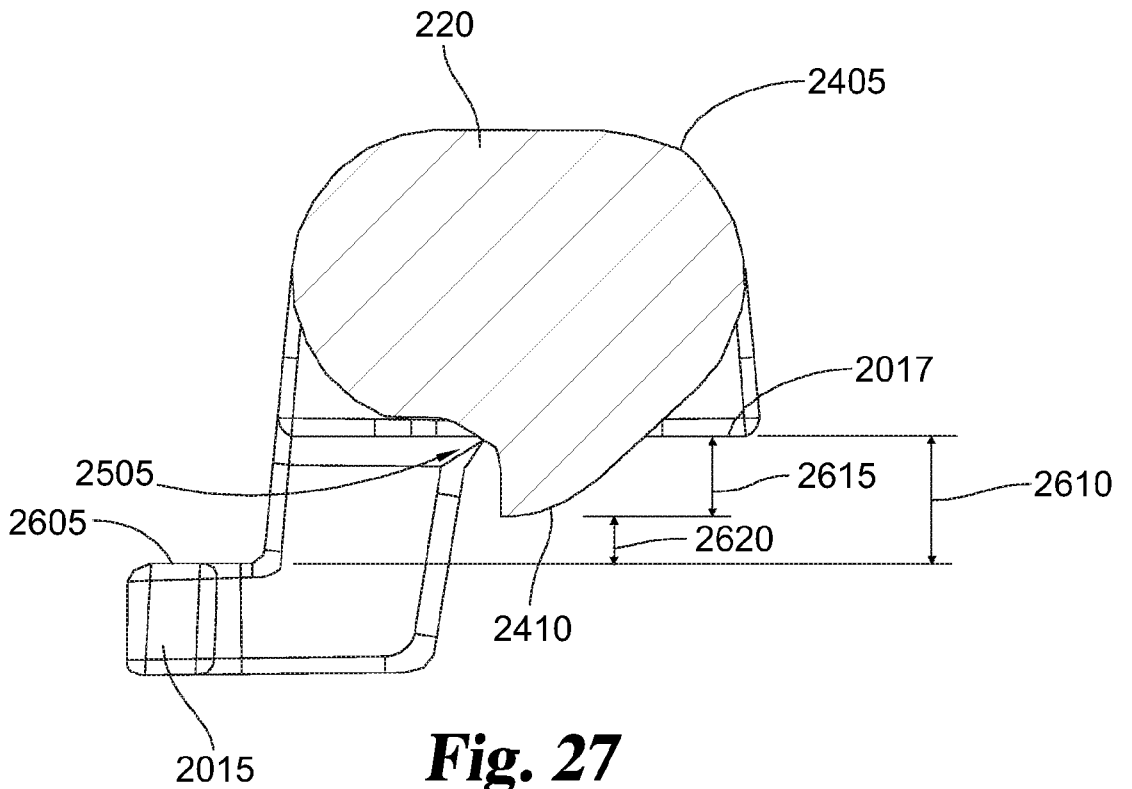

Fig. 27

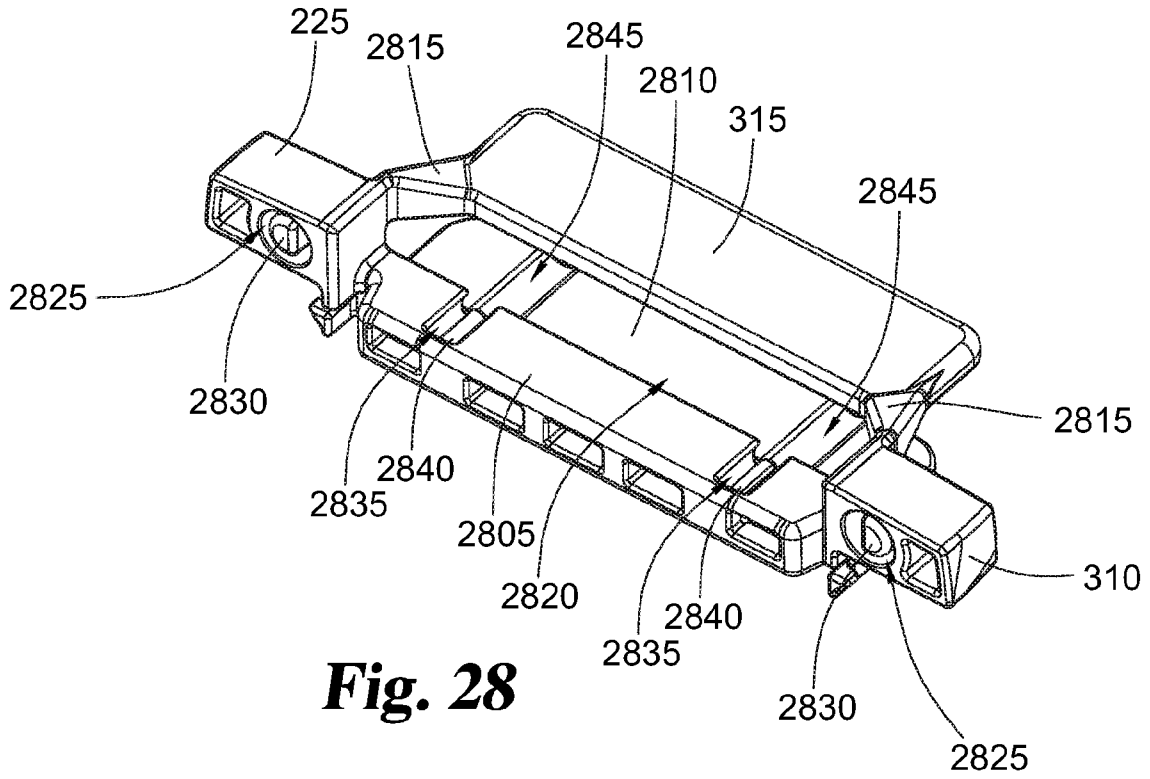

Fig. 28

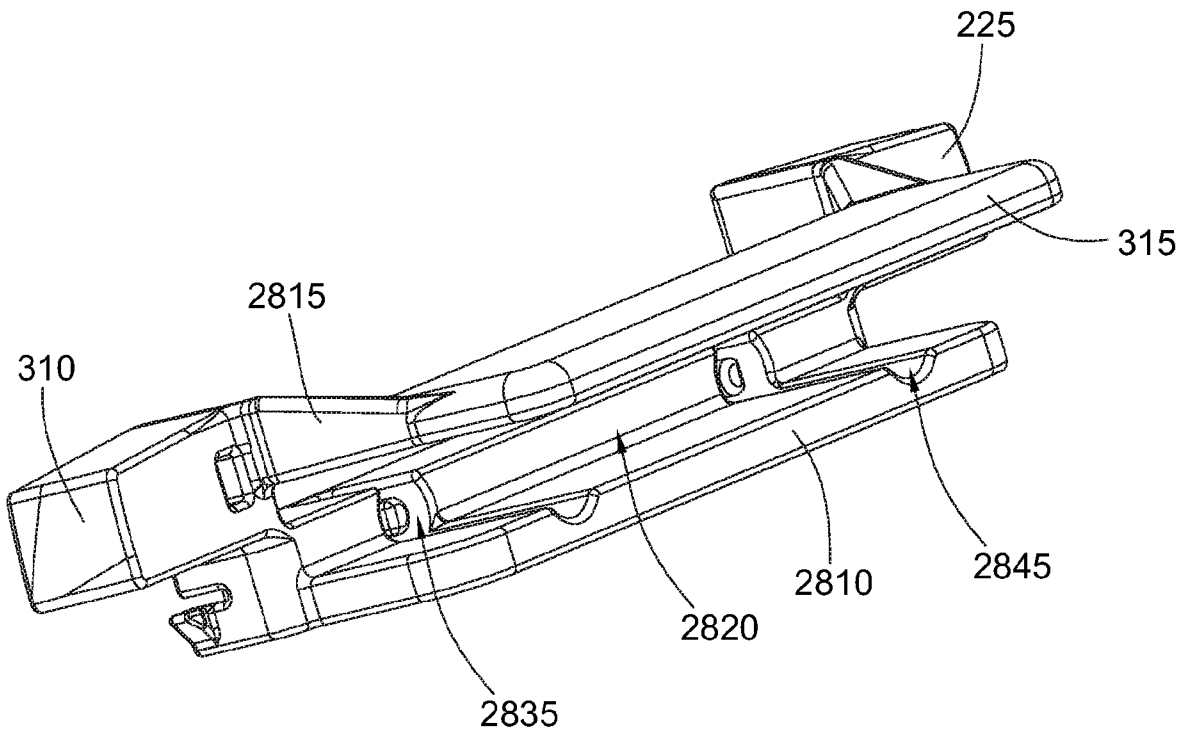

Fig. 29

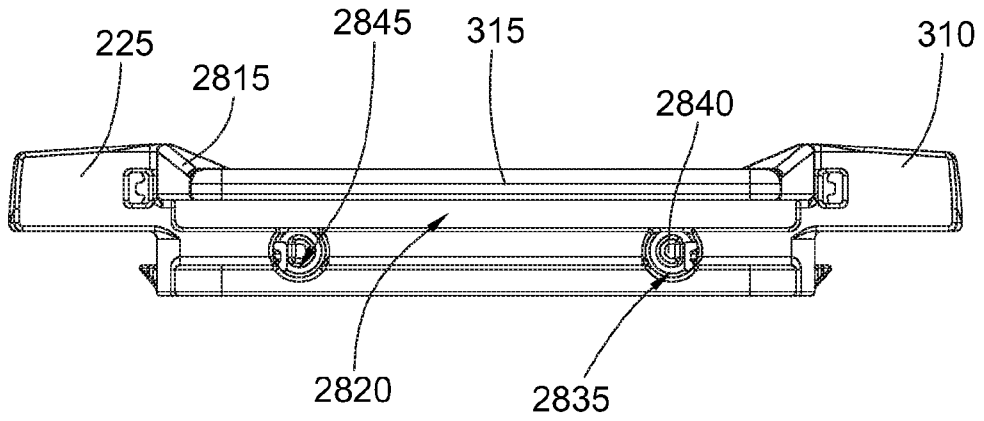

Fig. 30

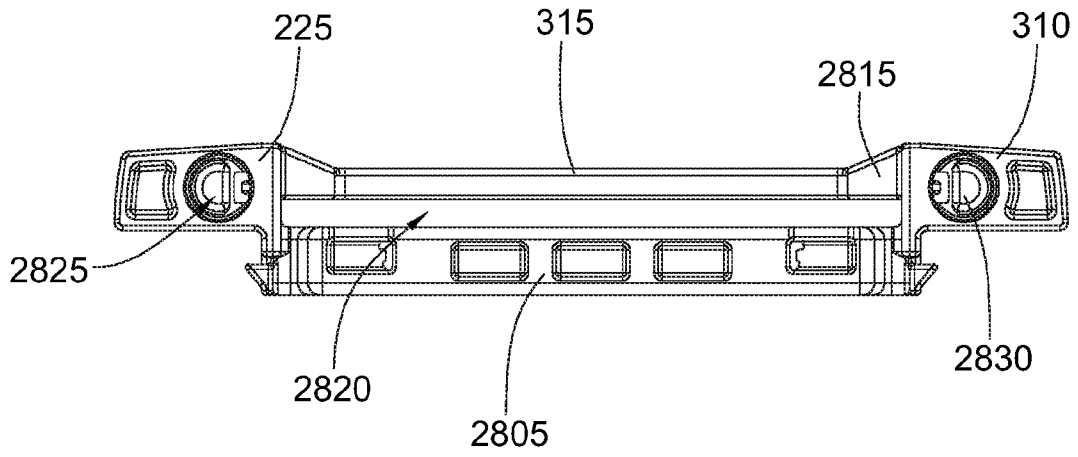

Fig. 31

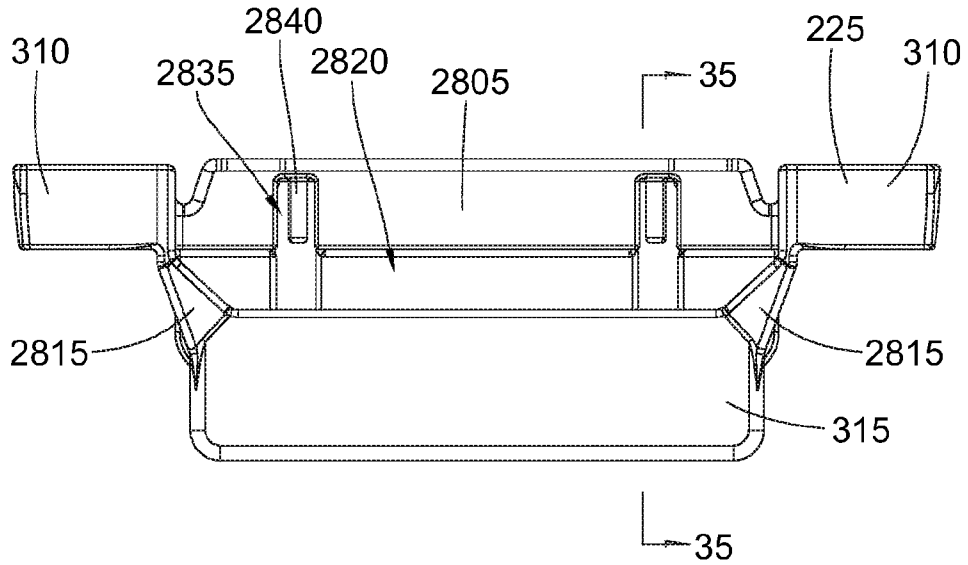

Fig. 32

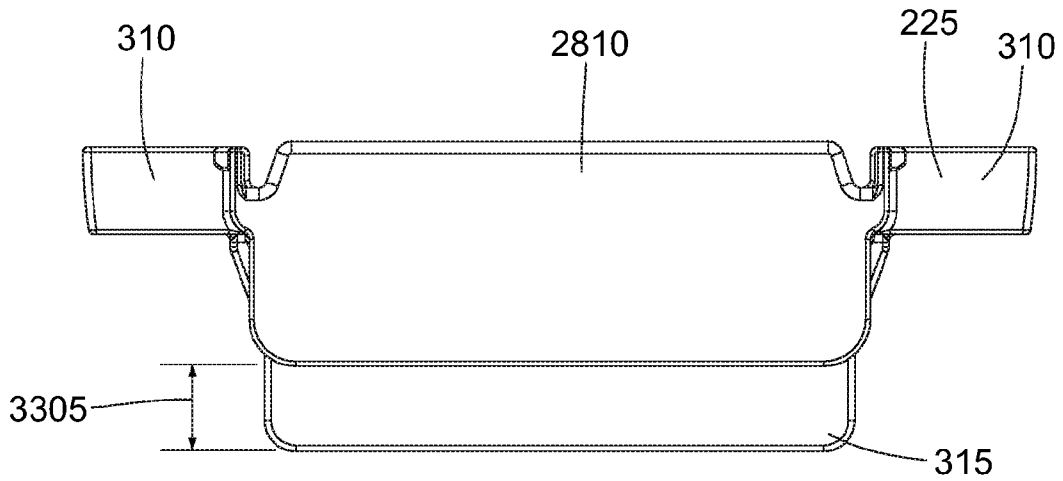
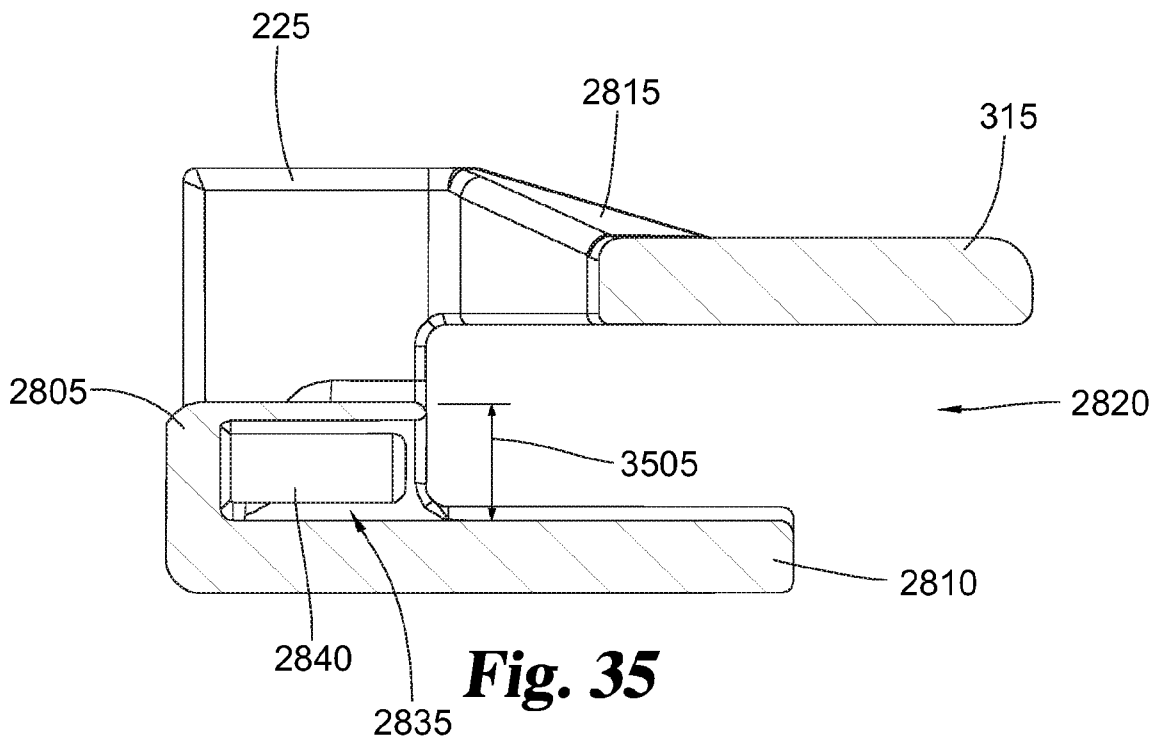
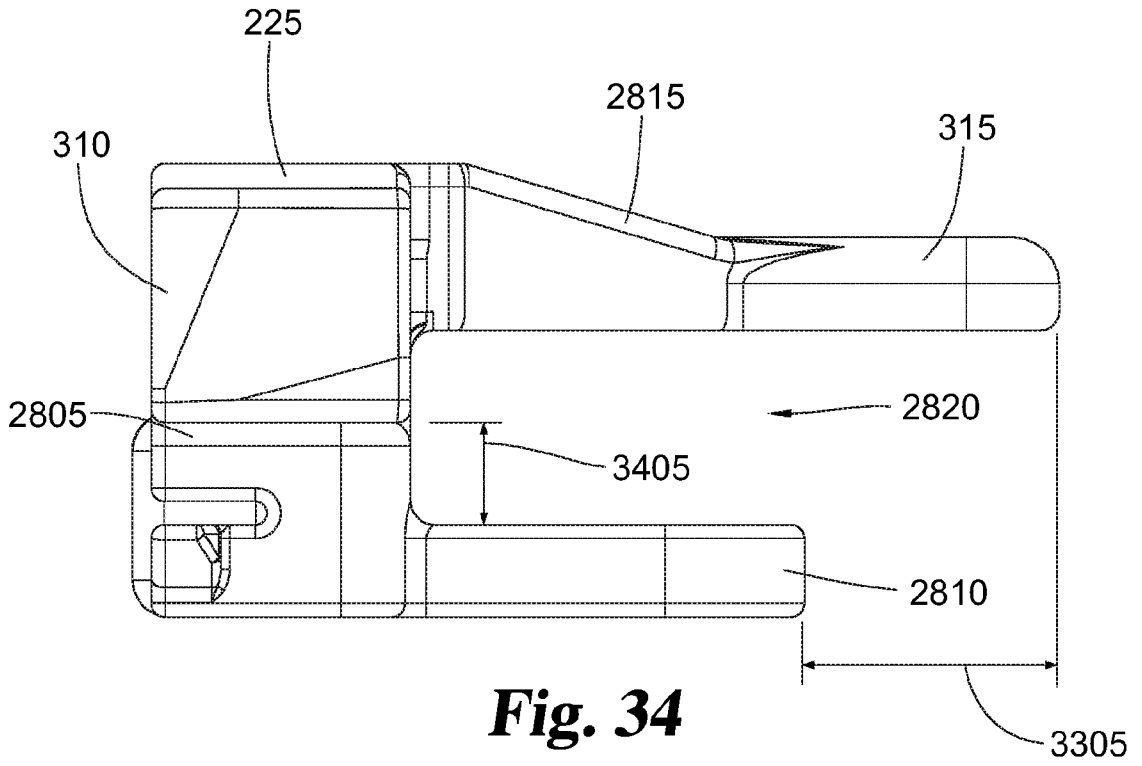
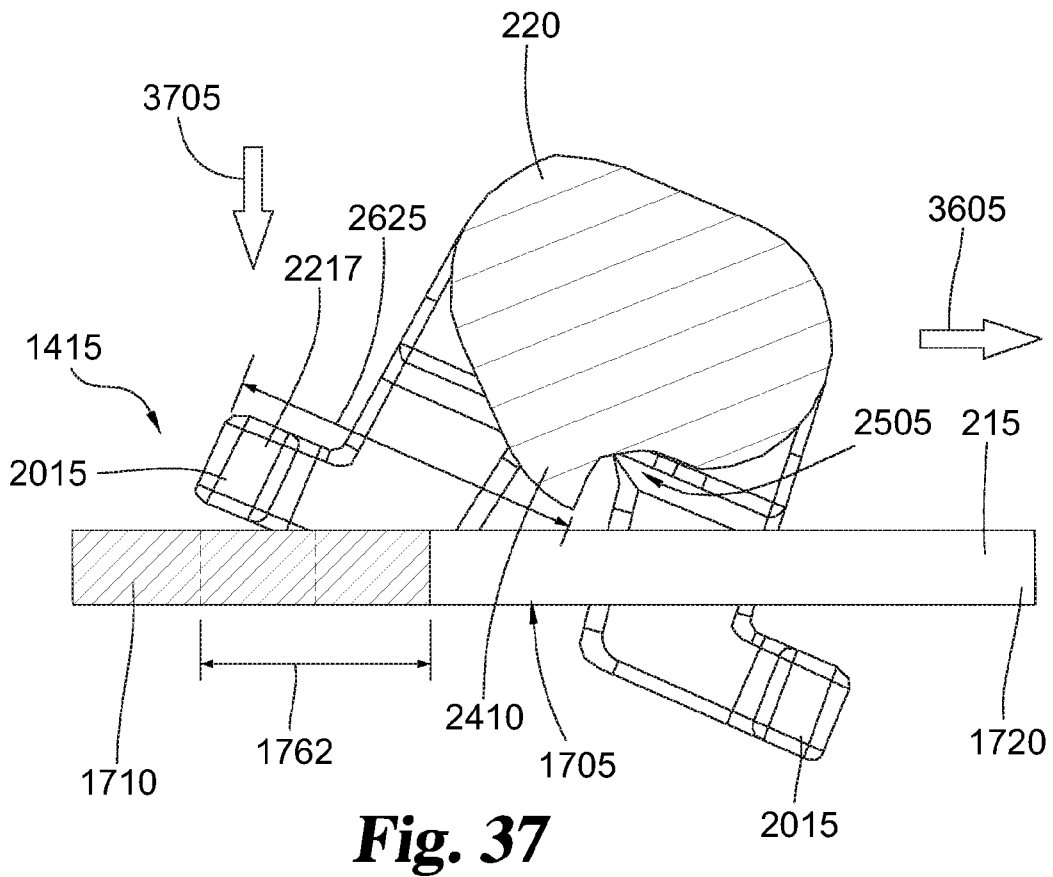
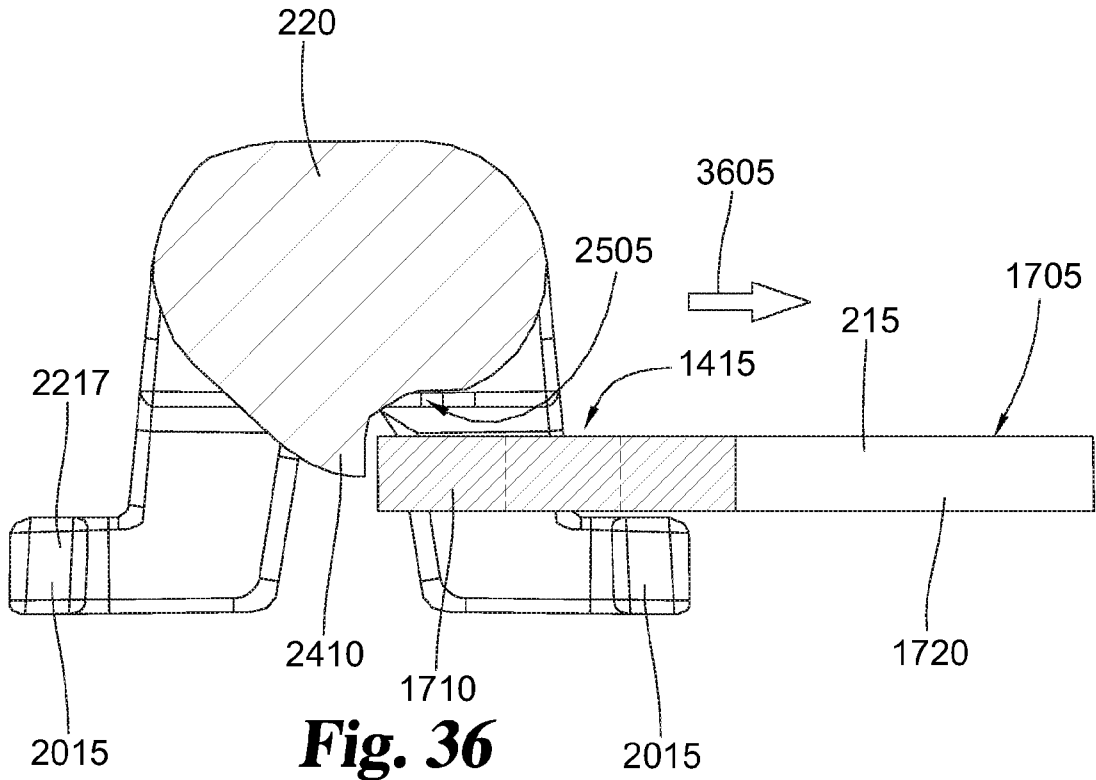

Fig. 33





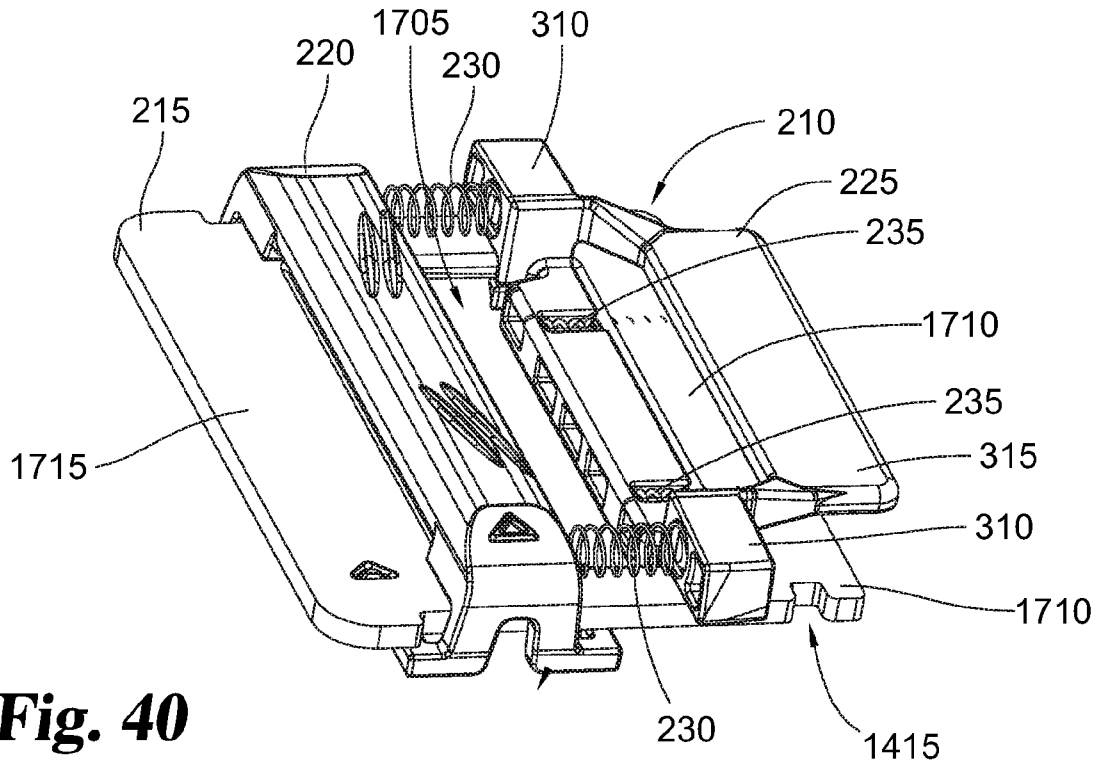

Fig. 40

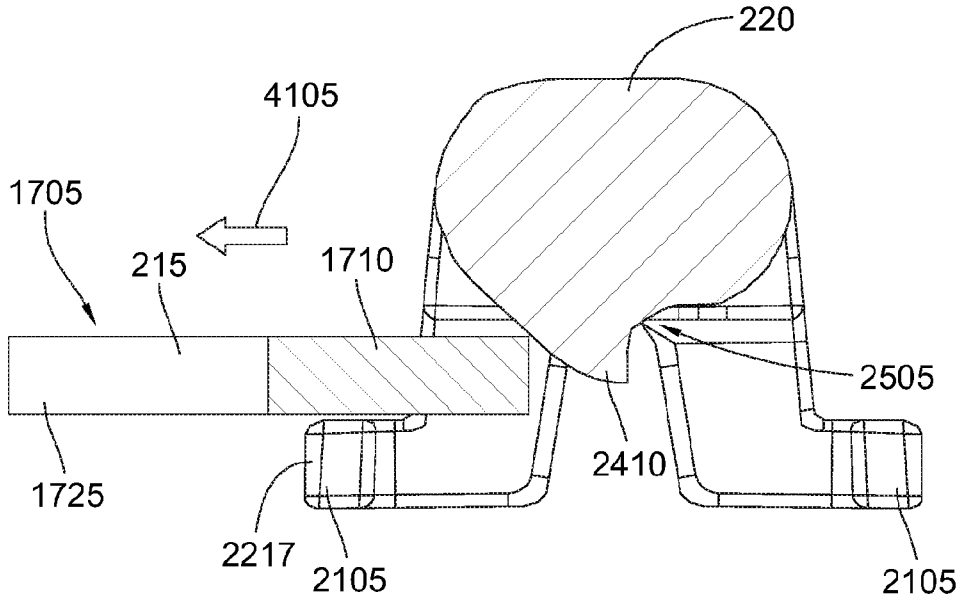

Fig. 41

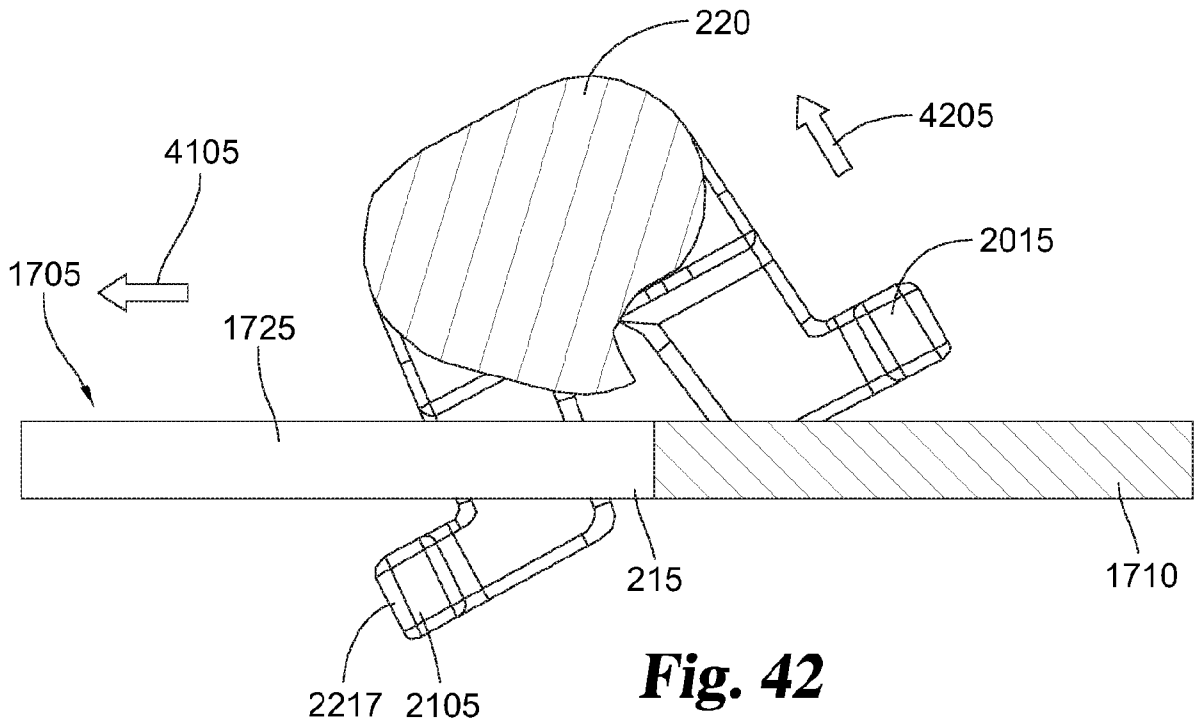

Fig. 42

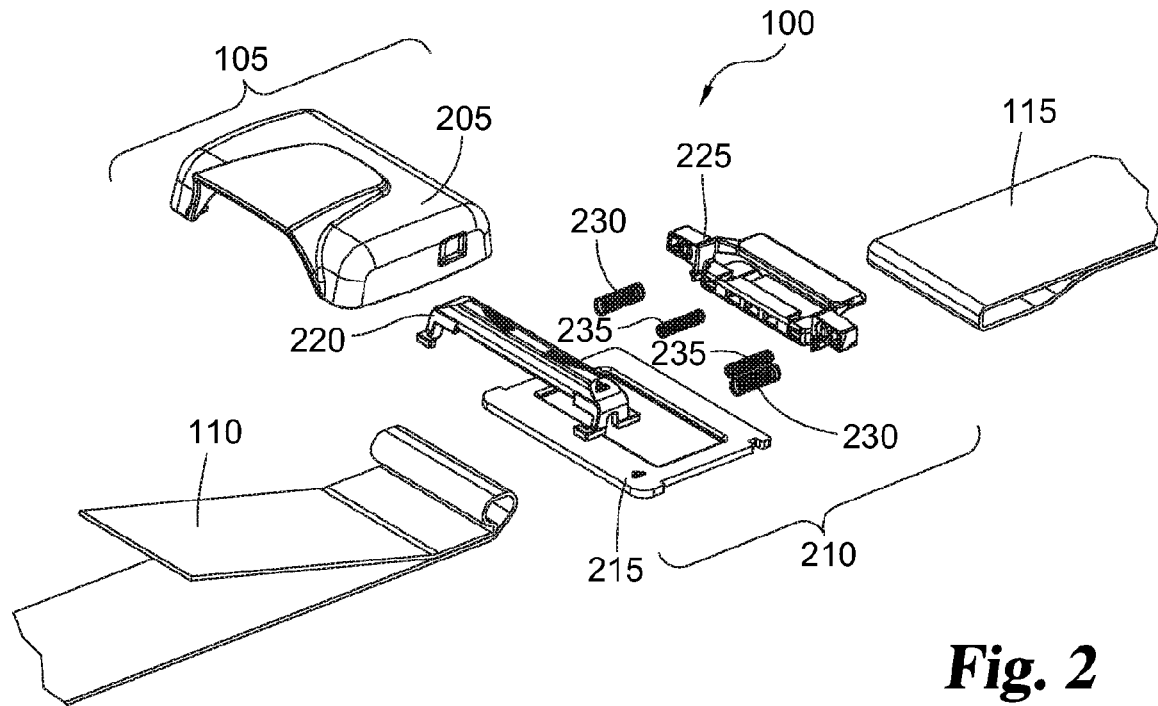

Fig. 2