



INTERNATIONAL APPLICATION PUBLISHED UNDER THE PATENT COOPERATION TREATY (PCT)

<p>(51) International Patent Classification⁴ : A01C 7/06, 5/08, A01B 49/06</p>	<p>AI</p>	<p>(11) International Publication Number: WO 88/ 05997 (43) International Publication Date: 25 August 1988 (25.08.88)</p>
<p>(21) International Application Number: PCT/SE88/00073 (22) International Filing Date: 19 February 1988 (19.02.88) (31) Priority Application Number: 8700681-3 (32) Priority Date: 19 February 1987 (19.02.87) (33) Priority Country: SE (71)(72) Applicant and Inventor: HANSSON, Kurt [SE/SE]; Norrback, S-733 00 Sala (SE). (74) Agent: LINDBLAD, Sture; Famtec AB, Box 7574, S- 103 93 Stockholm (SE). (81) Designated States: AT (European patent), AU, BE (Eu- ropean patent), CH (European patent), DE (European patent), DK, FI, FR (European patent), GB (Euro- pean patent), IT (European patent), LU (European patent), NL (European patent), NO, SE (European patent), SU, US.</p>		<p>Published With international search report. In English translation (filed in Swedish).</p>
<p>(54) Title: AGRICULTURAL COMBINED DRILL DISPENSER</p>		

(57) Abstract

Apparatus in an agricultural combination machine for simultaneously inserting and positioning in the earth of at least two components, e.g. seed and fertilizer, primarily a combination machine for direct sowing on a field without previous soil cultivation of the ground by ploughing, harrowing or the like, and including a means cutting the earth, e.g. a disc coultter, a knife coultter or the like, and at least two tubular discharge means, one for each component, the cutting means and discharging means extending down into the earth under the earth surface. The means for cutting (2) and means for discharge (5, 6) are removably attached to a coultter arm (1) and to each other to be allowed displacement upwards and downwards such that they are mutually relatively adjustable in depth to given working depths under the earth surface.

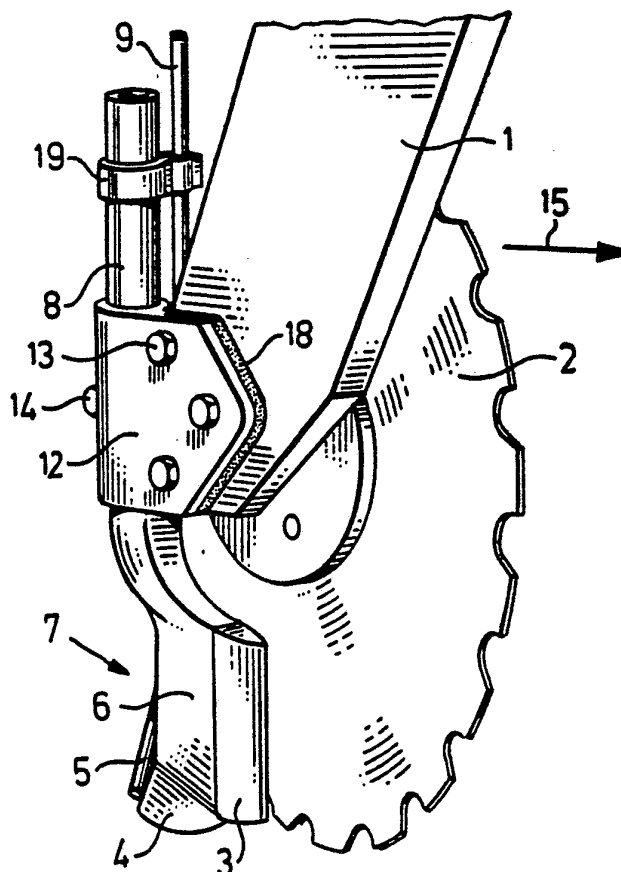

FOR THE PURPOSES OF INFORMATION ONLY

Codes used to identify States party to the PCT on the front pages of pamphlets publishing international applications under the PCT.

AT Austria	FR France	ML Mali
AU Australia	GA Gabon	MR Mauritania
BB Barbados	GB United Kingdom	MW Malawi
BE Belgium	HU Hungary	NL Netherlands
BG Bulgaria	IT Italy	NO Norway
BJ Benin	JP Japan	RO Romania
BR Brazil	KP Democratic People's Republic of Korea	SD Sudan
CF Central African Republic	KR Republic of Korea	SE Sweden
CG Congo	LI Liechtenstein	SN Senegal
CH Switzerland	LK Sri Lanka	SU Soviet Union
CM Cameroon	LU Luxembourg	TD Chad
DE Germany, Federal Republic of	MC Monaco	TG Togo
DK Denmark	MG Madagascar	US United States of America
FI Finland		

AGRICULTURAL COMBINED DRILL DISPENSER

The invention relates to a combined machine in accordance with the preamble to claim 1.

5 Combined machines for simultaneous spreading of seed and commercial fertilizer in agriculture are known, e.g. from the US Patent 3.213.812, which illustrates an apparatus with two mutually, relatively fixed outlet nozzles, arranged side by side and at different working depths under the earth surface. One condition for the apparatus is that earth can be led in between the nozzles (see Figure 5 of the patent specification), i.e. that the
10 apparatus is intended for fields which are worked by ploughing and harrowing, or in some other way. For sowing seed directly into place in the earth, i.e. farming without ploughing it has been necessary to supply fertilizer
15 in a separate pass or on top of the earth. In addition, the combination sowing machines have only been able to place fertilizer between alternate rows of seed.

Another known technique is apparent from SE 130.953, which is an apparatus for use in sowing directly onto
20 unworked ground.

The object of the invention is to solve the above mentioned problems and to develop an apparatus for combined dispensing, e.g. of seed and fertilizer in direct sowing by simultaneous insertion into the earth and such
25 that the distance laterally between seed and fertilizer may be varied to desired values, while the depths of insertion under the earth surface can be adjusted to different, desired values quite independent of each other for the seed and fertilizer. This signifies a great advantage, since different combinations of seed types and fertilizer types as well as the character and composition of
30 different earths require different procedures for dispensing and distribution.

The object is achieved by the invention having been given the characterizing features disclosed in the claims.

The invention will now be described with the aid of an embodiment example and in connection with the attached drawings, where

Figure 1 is a perspective view of the apparatus seen obliquely from the front in relation to the working direction,

Figure 2 illustrates the lower part of the apparatus in Figure 1 seen from one side,

Figure 3 illustrates the apparatus from behind,

Figure 4 is a partially sectioned view transverse the working direction of the bottommost part of the apparatus in Figure 3 while working in the ground,

Figure 5 is a section according to V-V in Figure 4 after the apparatus has completed dispensing at different depths,

Figure 6 is a schematic view from above, illustrating lateral dispensing according to VI-VI in Figure 5,

Figure 7 is a section seen from above according to VII-VII in Figure 2,

Figure 8 is a corresponding view according to VIII-VIII in Figure 2.

In Figure 1 the numeral 1 denotes the coulter arm of a disc coulter 2 and a combination share 7, including a discharge pipe 5 for fertilizer and a discharge pipe 6 for seed. Seed and fertilizer are fed to the outlet means 6 and 5 via the feed pipes 8 and 9. The clamp 12 is connected to the coulter arm 1 with the aid of three screws 13. An elastic element 18, e.g. of rubber, is arranged between the clamp 12 and the arm 1. The position and direction of the combination share 7 can be varied within certain limits by tightening the three screws 13 to different amounts. A clip 19 is provided for keeping the feed pipes 8 and 9 together.

Figure 1 also illustrates a share 3, which is fixed to the forward portion of the discharge pipe 6 for seed, and this pipe has a forwardly-downwardly directed share 4 at its lower portion. When the share moves in the working direction 15 through the earth, the share 4 will be subjected to a downwardly directed force. This facilitates the travel of the feed means in earth which is hard or which contains plant residue.

In Figure 2 the denotations are the same as in Figure 1 for the same details, and the arrow 15 denotes the working direction of the disc coulter 2.

Figure 3 illustrates the clamp 12 from behind and how it connects the details 3-9 to the arm 1 with the aid of a bolted joint 14. By loosening the bolted joint 14, the discharge pipe 6 and feed pipe 8 for seed, as well as the discharge pipe 5 and feed pipe 9 for fertilizer may be moved both vertically and laterally for being re-clamped in new positions relative each other and the arm 1.

Figure 4 illustrates the apparatus in more detail where, apart from previous details, the outlet opening for seed is denoted by the numeral 10 and the outlet opening for fertilizer is denoted by 11. The dispensed seed is denoted by 16 and the dispensed fertilizer by 17. In an actual case, the lateral distance between seed and fertilizer can be up to 20-40 mms. Depending on the type of seed and fertilizer, as well as the properties of the earth, a suitable lateral distance can be given other values. The dispensing depth for seed may be 30-40 mms and for fertilizer 50-80 mms. Of course, these values can also be varied depending on circumstances. Usually, the difference between dispensing depths for seed and fertilizer is from 20 to 60 mms, the fertilizer share 4 then being at the greater depth.

The disc coulter 2 opens a furrow in the unworked ground. The combination share 7 operates in this furrow, the fertilizer discharge pipe 5, its feed pipe 9 and the lower part of the pipe 6 being situated in a protected position behind the seed share 3 when the combination share 7 traverses the ground in the working direction.

Figure 5 illustrates how the seed 16 and fertilizer 17 are placed side by side, although at different depths as will be seen from Figure 4.

Figure 6 illustrates how seed 16 and fertilizer 17 are situated in relation to each other and to the earth surface after the disc coulter 2 and combination share 7 have passed, and how the furrow that has been made has closed at an interface 20.

Figure 7 is a section through the apparatus just above the earth surface, as is denoted in Figure 2 by the section VII-VII. The interface 20 left behind by the furrow is formed at a short distance behind the disc coulter 2 and combination share 7.

Figure 8 is a section through the combination share 7 during its operation and just under the earth surface, see section VIII-VIII in Figure 2. Seed 16 and fertilizer 17 have been dispensed and the furrow is in the process of closing into the interface 20 above seed and fertilizer.

Within the scope of the invention, one skilled in the art can achieve other embodiments than the one illustrated for the purpose of exemplification. For example, the discharge means may comprise a so-called broad shoe coulter for band drilling or a "Duck foot" share, which can have a broad share for broadcast seeding.

CLAIMS

1. Apparatus in an agricultural combination machine for simultaneously inserting and positioning in the earth of at least two components, e.g. seed and fertilizer, primarily a combination machine for direct sowing on a field without previous soil cultivation by ploughing, harrowing or the like, and including a means cutting the earth, e.g. a disc coulter, a knife coulter or the like, and at least two tubular discharge means, one for each component, the cutting means and discharging means extending down into the earth under the earth surface, characterized in that the means for cutting (2) and means for discharge (5, 6) are removably attached to a coulter arm (1) and to each other such that they are allowed displacement upwards and downwards such that their depths are mutually relatively adjustable to individual working depths under the earth surface.

2. Apparatus as claimed in claim 1, characterized in that the means (2, 5, 6) are relatively adjustable laterally with the aid of loosenable connection means (12, 13, 14, 18).

3. Apparatus as claimed in claim 2, characterized in that the outlet means (5, 6) are loosenable attached to each other and are connected to the coulter arm (1) with the aid of a loosenable connection means (12-14, 18) which includes an elastic element (18), e.g. of rubber, such that the connection will allow varying position and direction between the outlet means (5, 6), arm (1) and cutting means (2) carried by the arm.

4. Apparatus as claimed in claim 1, characterized in that in the working direction the outlet means (5, 6) are arranged behind the cutting means (2), and implemented such that they extend downwards into the furrow made by the cutting means.

5. Apparatus as claimed in claim 1, c h a r a c t-
e r i z e d in that one of the outlet means (6) is
adapted for seed (16) and another outlet means (5) is
adapted for fertilizer (17), and formed such that the
5 outer portion of the means (5) is bent outwards transverse
the working direction (15) such that said outward portion
opens out (11) to one side of, and at a greater working
depth than the depths of the outlet means (10) for the
seed (16).

10 6. Apparatus as claimed in claim 1, c h a r a c t-
e r i z e d in that one discharge means (6) has at its
downward-forward end a downwardly-forwardly directed share
(4) intended to engage with the earth for achieving a force
acting in a downward direction on the discharge means (6)
15 such as to facilitate the travel of the means in hard
earth or in earth containing plant residue.

7. Apparatus as claimed in claim 5, c h a r a c t-
e r i z e d in that the outward portion of the outlet
means for fertilizer opens out (11) laterally at prefer-
20 ably 20-40 mms from the outlet means (10) for seed and
preferably 20-60 mms deeper than this means (10).

Fig. 1

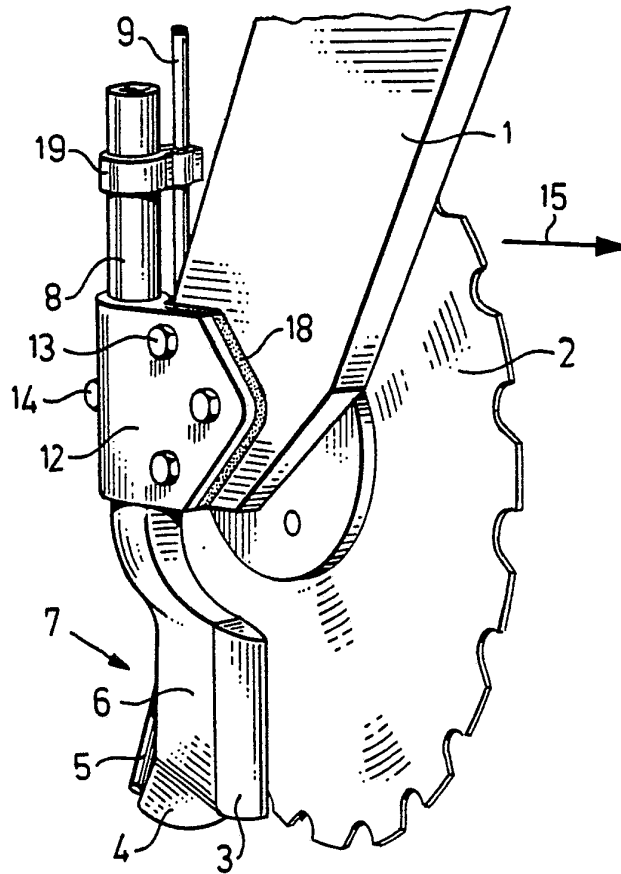

Fig. 3

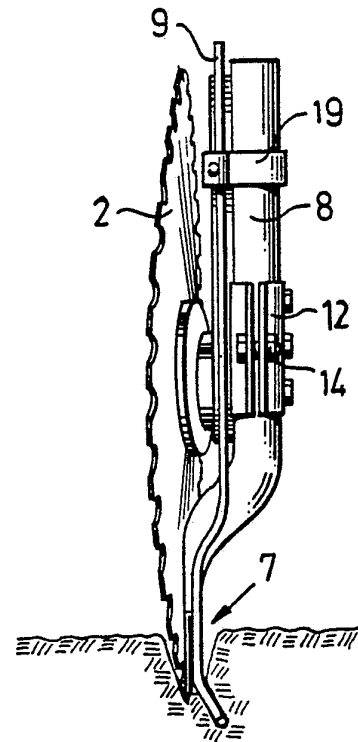

Fig. 2

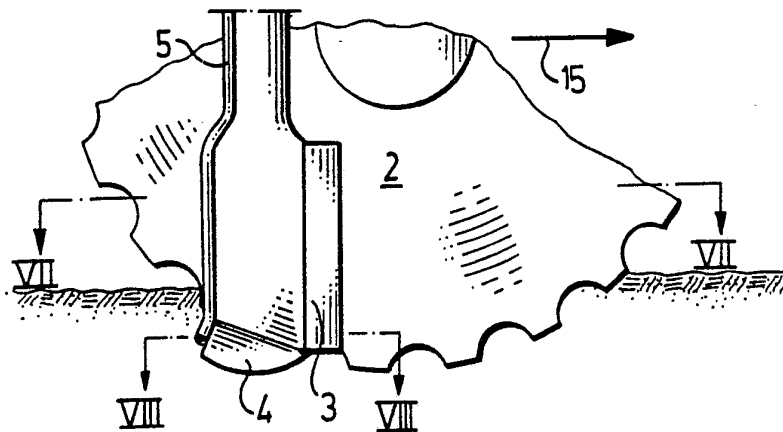

Fig. 4

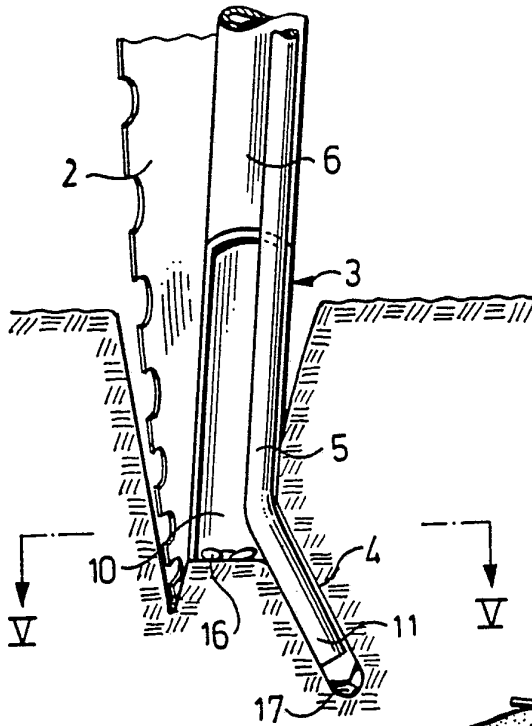

Fig. 5

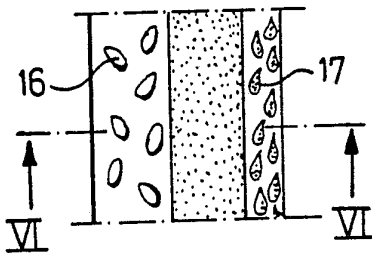

Fig. 7

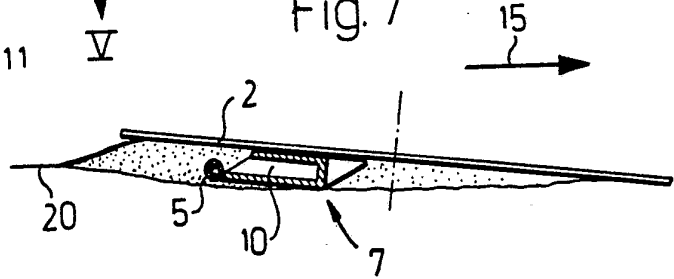

Fig. 8

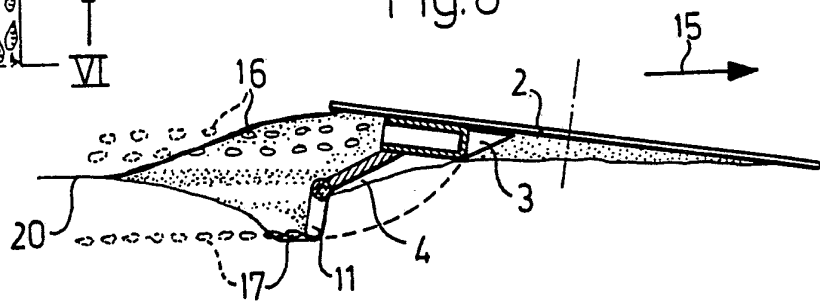
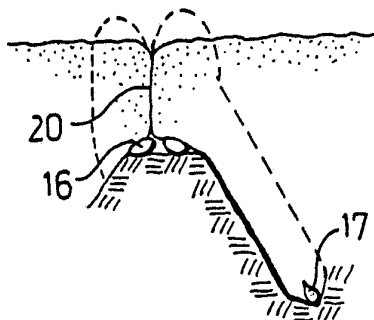



Fig. 6



INTERNATIONAL SEARCH REPORT

PCT/SE88/00073

International Application No

I. CLASSIFICATION OF SUBJECT MATTER (if several classification symbols apply, indicate all) ⁶ According to International Patent Classification (IPC) or to both National Classification and IPC ⁴ A 01 C 7/06, 5/08, A 01 B 49/06	
II. FIELDS SEARCHED Minimum Documentation Searched ⁷	
Classification System	Classification Symbols
IPC 4	A 01 C 5/00, /06, /08, 7/00, /06, /20; A 01 B 49/00, /04, /06, 63/00, /24, /26
US Cl	111:14, 69, 73, 79-81, 83, 85-88; 239:656
Documentation Searched other than Minimum Documentation to the Extent that such Documents are Included in the Fields Searched ⁸	
SE, NO, DK, FI classes as above	
III. DOCUMENTS CONSIDERED TO BE RELEVANT ⁹	
Category ⁹	Citation of Document, ¹¹ with Indication, where appropriate, of the relevant passages ¹²
Y A	FR, A, 2 408 288 (MOORE SAMUEL) 8 June 1979
Y	DE, Cl, 3 332 964 (AMAZONEN-WERKE H.DREYER GMBH & CO KG) 24 January 1985
Y	US, A, 2 808 792 (A.E. BRICKMAN) 8 October 1957
Y A	US, A, 3 213 812 (C.H. FORSYTH ET AL) 26 October 1965
A	US, A, 601 017 (R.L. HUDSON) 22 March 1898
A	US, A, 1 006 771 (P.M. METZLER) 24 October 1911
A	US, A, 2 920 587 (G.H. SHRIVER) 12 January 1960
A	US, A, 3 122 111 (W.A. TAYLOR, SR) 25 February 1964 .../...
Relevant to Claim No. ¹³	1 3 1 1 4, 5 1, 7 1, 4, 6
* Special categories of cited documents: ¹⁰ "A" document defining the general state of the art which is not considered to be of particular relevance "E" earlier document but published on or after the international filing date "L" document which may throw doubts on priority claim(s) or which is cited to establish the publication date of another citation or other special reason (as specified) "O" document referring to an oral disclosure, use, exhibition or other means "P" document published prior to the international filing date but later than the priority date claimed "T" later document published after the international filing date or priority date and not in conflict with the application but cited to understand the principle or theory underlying the invention "X" document of particular relevance; the claimed invention cannot be considered novel or cannot be considered to involve an inventive step "Y" document of particular relevance; the claimed invention cannot be considered to involve an inventive step when the document is combined with one or more other such documents, such combination being obvious to a person skilled in the art. "A" document member of the same patent family	
IV. CERTIFICATION	
Date of the Actual Completion of the International Search 1988-05-05	Date of Mailing of this International Search Report 1988 -05- 16
International Searching Authority Swedish Patent Office	Signature of Authorized Officer  Asa Fransson

III. DOCUMENTS CONSIDERED TO BE RELEVANT (CONTINUED FROM THE SECOND SHEET)

Category *	Citation of Document, with indication, where appropriate, of the relevant passages	Relevant to Claim No
A	US, A, 3 362 361 (J.E. MORRISON, JR) 9 January 1968	1,2,7
A	GB, A, 1 262 903 (RENE LOUIS BERNARD BENAC ET AL) 9 February 1972	1,2,7