



(51) International Patent Classification:

F02M 35/02 (2006.01) B01D 46/64 (2022.01)
B01D 46/00 (2006.01) F02M 35/024 (2006.01)
B01D 46/24 (2006.01)

(21) International Application Number:

PCT/US2022/077561

(22) International Filing Date:

05 October 2022 (05.10.2022)

(25) Filing Language:

English

(26) Publication Language:

English

(30) Priority Data:

17/452,214 25 October 2021 (25.10.2021) US

(71) Applicant: CATERPILLAR INC. [US/US]; 100 NE Adams Street - AH9510, Peoria, Illinois 61629-9510 (US).

(72) Inventor: CALIENDO, Vincent P.; 12130 N. Tall Trees Dr., Dunlap, Illinois 61525 (US).

(74) Agent: JACOBS, Jeffrey K. et al.; CATERPILLAR INC., 100 NE Adams Street - AH9510, Peoria, Illinois 61629-9510 (US).

(81) Designated States (unless otherwise indicated, for every kind of national protection available): AE, AG, AL, AM, AO, AT, AU, AZ, BA, BB, BG, BH, BN, BR, BW, BY, BZ, CA, CH, CL, CN, CO, CR, CU, CV, CZ, DE, DJ, DK, DM, DO, DZ, EC, EE, EG, ES, FI, GB, GD, GE, GH, GM, GT, HN, HR, HU, ID, IL, IN, IQ, IR, IS, IT, JM, JO, JP, KE, KG, KH, KN, KP, KR, KW, KZ, LA, LC, LK, LR, LS, LU, LY, MA, MD, MG, MK, MN, MW, MX, MY, MZ, NA, NG, NI, NO, NZ, OM, PA, PE, PG, PH, PL, PT, QA, RO, RS, RU, RW, SA, SC, SD, SE, SG, SK, SL, ST, SV, SY, TH, TJ, TM, TN, TR, TT, TZ, UA, UG, US, UZ, VC, VN, WS, ZA, ZM, ZW.

(84) Designated States (unless otherwise indicated, for every kind of regional protection available): ARIPO (BW, GH, GM, KE, LR, LS, MW, MZ, NA, RW, SD, SL, ST, SZ, TZ, UG, ZM, ZW), Eurasian (AM, AZ, BY, KG, KZ, RU, TJ, TM), European (AL, AT, BE, BG, CH, CY, CZ, DE, DK,

(54) Title: FILTER SYSTEM

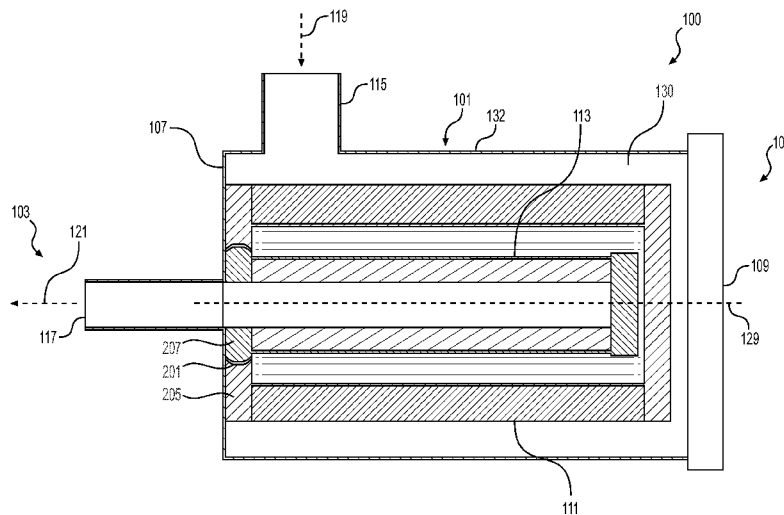

FIG. 1

(57) Abstract: Systems and methods for coupling filter elements to at least one flange (201) extending inside a housing (101) are disclosed. In one aspect, a filter system (100) may include a housing (101) having an inlet (115), an outlet (117), a first end (103), a second end (105), a sidewall (132) extending between the first end (103) and the second end (105), a longitudinal centerline (129), and at least one flange (201) extending inside the housing (101); and a plurality of filter elements located inside the housing (101), the plurality of filter elements each including an end shaped to couple directly to the at least one flange (201).



EE, ES, FI, FR, GB, GR, HR, HU, IE, IS, IT, LT, LU, LV,
MC, ME, MK, MT, NL, NO, PL, PT, RO, RS, SE, SI, SK,
SM, TR), OAPI (BF, BJ, CF, CG, CI, CM, GA, GN, GQ,
GW, KM, ML, MR, NE, SN, TD, TG).

Published:

— *with international search report (Art. 21(3))*

Description

FILTER SYSTEM

Technical Field

The present disclosure relates generally to internal combustion
5 engine systems, and more particularly, to a filter system of an internal
combustion engine system.

Background

Air filters may act as a barrier between the outside air filled with
contaminants and the sensitive interior of the internal combustion engine. These
10 air filters need to be securely sealed to the housing to prevent air leakage and
displacement during engine operation, e.g., air filters may be held against each
other by a compressive force provided by the housing. An accurate sealing of the
air filters to the housing may also prevent dust-laden outside air from entering the
sensitive interior of the internal combustion engine. However, depending on the
15 configuration of the components of the filter system, it may be difficult to
provide a sufficiently air-tight sealing. For example, a radial seal utilized for
sealing filter elements to a filter housing may have a limited sealing surface and
may provide uncertainty in sealing. The efficiency of the air filters characterizes
the quantity and the dimensions of dust particles that may pass through the air
20 filters, and may cause engine wear resulting in performance loss, increased
exhaust emissions, higher maintenance and operation cost, or premature engine
failure.

A separation apparatus for separating oil from gas is disclosed in
U.S. Patent No. 10,668,421 B2 (“the ’421 patent”) to *Zinic* issued on June 2,
25 2020. The air/oil separation apparatus includes a housing enclosing a filter
element. The housing includes a housing cover which is attached to a fastening
section for securing to a stationary connection nipple. This fastening section of
the housing includes an annular seal having a curved cross-section. However, the

'421 patent does not disclose a system for coupling or removing the filter elements from the housing.

The disclosed filter assembly may solve one or more problems of the systems described above and/or other problems in the art. The scope of the current disclosure, however, is defined by the attached claims, and not by the ability to solve any specific problem.

Summary

In one aspect, a filter system may include a housing having an inlet, an outlet, a first end, a second end, a sidewall extending between the first end and the second end, a longitudinal centerline, and at least one flange extending inside the housing; and a plurality of filter elements located inside the housing, the plurality of filter elements each including an end shaped to couple directly to the at least one flange.

In another aspect, a filter assembly may include a first filter element having a first outlet end including a first opening; a second filter element having a second outlet end including a second opening; and the first and second outlet ends of the first and second filter elements include coupling surfaces having complementary shapes.

In a further aspect, a filter assembly may include a first cylindrical filter element having a first outlet end including a first opening; a second cylindrical filter element having a second outlet end including a second opening, wherein the first filter element is sized to be located within the second filter element; and the first and second outlet ends of the first and second filter elements include coupling surfaces having complementary C-shapes, wherein the complementary shapes are located about a radially inner surface of the first opening of the first filter element, and located on a radially outer surface of the second outlet end of the second filter element.

Other features and aspects of this disclosure will be apparent from the following description and the accompanying drawings.

Brief Description of the Drawings

The accompanying drawings, which are incorporated in and constitute a part of the specification, are illustrative of one or more embodiments and, together with the description, explain the embodiments. The accompanying drawings have not necessarily been drawn to scale. Further, any values or dimensions in the accompanying drawings are for illustration purposes only and may or may not represent actual or preferred values or dimensions. Where applicable, some or all select features may not be illustrated to assist in the description and understanding of underlying features.

10 FIG. 1 is a cross-sectional view of an exemplary filter assembly, according to aspects of the present disclosure;

 FIG. 2 is a sectional view of a filter coupling portion of the filter assembly of FIG. 1 prior to filter coupling;

 FIG. 3 is an enlarged view of the filter coupling portion of FIG. 2;
15 and

 FIG. 4 is a sectional view of a filter coupling portion of the filter assembly of FIG. 1 after filter coupling.

Detailed Description

Both the foregoing general description and the following detailed description are exemplary and explanatory only and are not restrictive of the features, as claimed. As used herein, the terms “comprises,” “comprising,” “having,” “including,” or other variations thereof, are intended to cover a non-exclusive inclusion such that a process, method, article, or apparatus that comprises a list of elements does not include only those elements, but may include other elements not expressly listed or inherent to such a process, method, article, or apparatus. Moreover, in this disclosure, relative terms, such as, for example, “about,” “substantially,” “generally,” and “approximately” are used to indicate a possible variation of $\pm 10\%$ in the stated value.

 FIG. 1 illustrates a cross-sectional view of an exemplary filter system 100, according to one or more embodiments. Filter system 100 may

include a housing 101 including an air inlet 115 and air outlet 117. Air inlet 115 includes an aperture or port extending through housing 101 for providing air flow communication with an interior 130 of housing 101. For example, intake air 119 may pass through air inlet 115 into the interior 130 of housing 101, and then
5 through a radially outer filter element 111, and a radially inner filter element 113 to filter the contaminants. Filtered air 121 may exit the interior of housing 101 through air outlet 117. In one instance, air outlet 117 may include an aperture or port extending through a first end wall 107 of housing 101, and may communicate with a compressor (not shown) of a turbocharger (not shown) of the
10 internal combustion engine. It should be noted that the filter system 100 may be used in a variety of applications without any limitation. The environments and applications of the filter system described herein are exemplary and do not limit the scope of the present disclosure.

The housing 101 of filter system 100 may include a sidewall 132
15 extending between a first, proximal, end 103, and a second, distal, end 105 opposite the first end 103. While the housing 101 is illustrated as generally cylindrical, the housing may have alternative shapes. First end 103 with first end wall 107 may include air outlet 117. First end wall 107 may be formed integral with, or otherwise not removable from sidewall 132 of housing 101. However, it
20 is understood that first end wall 107 may be removable from the rest of the housing 101 if desired. Second end 105 of housing 101 may include a second end wall 109. Second end wall 109 may include a removable cover, cap, or the like for providing access to the interior 130 of housing 101.

As discussed in more detail below, second end wall 109 may be
25 removed to insert or replace a plurality of air filter elements, e.g., first filter element 111 and second filter element 113, within housing 101. Filter elements 111 and 113 may include any filter material known in the art, e.g., a pleated paper material or the like for filtering particulates, e.g., dust or soot, from the intake air. Filter elements 111 and 113 may have a cylindrical shape, however, it is
30 understood that these filter elements may include any other shapes as desired. In one instance, filter elements 111 and 113 may include end walls opposite their

respective outlet ends. As will be described in more detail below, filter elements 111 and 113 may include proximal outlet ends including a proximal base 205 of first filter element 111, and a proximal base 207 of second filter element 113.

FIG. 2 illustrates a sectional view of the proximal or outlet end 103 of housing 101. An internal sidewall of first end wall 107 may include a filter support or coupling member in the form of a flange 201. Flange 201 may be shaped, sized, and configured to receive and support both filter elements 111 and 113, and is located adjacent to air outlet 117 of housing 101. For example, flange 201 may surround outlet 117 and extend integrally from the interior surface of first end wall 107, or may be attached by any means to the interior of first end wall 107. In one instance, flange 201 is a single annular flange extending distally from the interior surface of first end wall 107 and may have a curved shape, such as the C-shape shown. The radially inner surface 220 of flange 201 may have a concave profile as viewed from longitudinal centerline 129 of housing 101. Also, the radially outer surface 222 of flange 201 may have a concave profile as viewed from longitudinal centerline 129 of housing 101. In one instance, flange 201 may be formed to a height of approximately 25 millimeter (mm) to 65 mm, a width of approximately 40 mm to 250 mm, a diameter of approximately 40 mm to 250 mm, and the inner and outer surfaces 220, 222 may have a radius of curvature of approximately 15 mm to 150 mm.

Still referring to FIG. 2, proximal base 205 of first filter elements 111 includes an annular body 230 and a filter media 232 extending distally therefrom. Annular body 230 includes a central opening 234 forming a coupling surface 236 for attaching to flange 201 of housing 101. The coupling surface 236 of annular body 230 may be shaped to match (be substantially similar to), or be shaped complementary to, the shape of radially outer surface 222 of flange 201. For example, the coupling surface 236 of annular body 230 shown in FIG. 2 matches the shape of outer surface 222 of flange 201 by having a concave, C-shape as viewed from the longitudinal centerline 129 of the filter housing 101. As used herein, a substantially similar or matching shape is one that is substantially the same shape along the flange 201, whereas a “complementary”

shape is one that may be matching, but does not necessarily have to match, but does allow for engagement and securement with flange 201. For example, coupling surface 236 of annular body 230 could include an alternative, complementary shape (not shown) such as a concave shape on a proximal half of coupling surface 236, and a planar surface on a distal half of coupling surface 236. Such an alternative shape would be “complementary” by allowing engagement with flange 201, but would not be matching because the coupling surface 236 would be a different shape at a distal portion of flange 201.

Also in FIG. 2, proximal base 207 of second filter element 113 includes an annular body 240 and a filter media 241 extending distally therefrom. Annular body 240 includes an outer radial surface forming a coupling surface 245 for attaching to flange 201 of housing 101. The coupling surface 245 of annular body 240 may match (be shaped substantially similar to), or be shaped complementary to, the shape of radially inner surface 220 of flange 201. For example, as shown in FIG. 2, the shape of coupling surface 245 may match the shape of inner surface 220 of flange 201 and include a concave, C-shape as viewed from the longitudinal centerline 129 of the filter housing 101. Further, the inner surface 220 and outer surface 222 of flange 201 have matching shapes, i.e., concave, C-shapes, and accordingly the coupling surfaces 236 and 245 of filter elements 111, 113 have matching shapes, i.e., concave, C-shapes.

FIG. 3 illustrates an enlarged view of the coupling assembly of filter elements 111 and 113 to flange 201. Arrows 250 represent movement of the filter elements 111, 113 along the flange 201 during the filter coupling process. The coupling may provide for a “snap-fit” connection. As used herein, a “snap-fit” connection or coupling includes a coupling where a portion of one coupling surface is smaller than a larger portion of the other coupling surface so that during the coupling process the smaller portion needs to move past the larger portion by way of deformation of one or both of the smaller or larger portions of the coupling surfaces. For example, as shown in FIG. 3, annular body 230 of filter element 111 includes coupling surface 236 having a radially smaller portion 238 (measured from longitudinal centerline 129) that needs to move past a

radially larger portion 242 of outer surface 222 of flange 201. Similarly, inner surface 220 of flange 201 includes a radially smaller portion 244 that a radially larger portion 246 of surface 245 needs to move past during coupling of the filter element 113 to flange 201. In such a coupling assembly, restraining portions are
5 located at opposite ends of the flange 201. In particular, a first restraining portion 252 is formed at proximal end of flange 201 for the annular body 230 of filter element 111, and a second restraining portion 254 is formed at a distal end of the flange 201 for the annular body 240 of filter element 113. Thus, the flange 201 provides for opposed or oppositely located restraining portions for the filter
10 elements 111, 113.

The annular bodies 230, 240 and flange 201 may be made of a flexible material to allow for the required deformation when coupling the filter elements 111, 113 to the flange 201. In one instance, flange 201 and proximal bases 205 and 207 may be formed of Ethyl carbamate, Carbamate, or
15 Polyurethane. It is understood that flange 201 and proximal bases 205 and 207 may include any other materials known in the art. For example, flange 201 may be formed of ultra-strong molded pliable rubber that absorbs vibration and allows for secure attachment.

While the exemplary embodiment depicts flange 201 and proximal
20 bases 205 and 207 as having concave, C-shaped coupling surfaces, however, it is understood that flange 201 and proximal bases 205 and 207 may be formed in alternative designs. For example, the curve could be switched and the surfaces can be oppositely oriented, i.e., convex with respect to the longitudinal centerline 129. The flange 201 may be segmented rather than fully annular. Flange 201
25 may form a distally pointing arrow, and coupling surfaces 236 and 245 may have a complementary shape including a step to allow an underside surface of the arrow to secure the proximal bases 205 and 207. In another alternative, and as reference above, coupling surface 236 and 245 could complementary shapes to flange 201, and include only partially curved portions, for example, only at
30 restraining portions 252 and 254.

FIG. 4 illustrates proximal end 103 with the filter elements 111, 113 connected to flange 201 of housing 101. As shown, flange 201 is located between proximal bases 205 and 207, and bases 205 and 207 are overlapping and coextensive in a proximal-distal direction.

5 Industrial Applicability

The disclosed filter system 100 may be employed in any air filter, for example, in air filters of an internal combustion engine. The disclosed filter system 100 may find particular applicability in machines operating in environments characterized by high levels of airborne dust, dirt, particulates, and other known debris. By equipping machines with filter system 100 of the present disclosure, damage to various components of such machines may be reduced and the operational efficiency of such machines may be improved based on the filtering and capability of replacing filter elements of the filter system 100.

With reference to FIGs. 1-4, intake air 119 may enter the interior of housing 101 of filter system 100 through air inlet 115. For example, the compressor of the internal combustion engine may provide a vacuum effect such that intake air 119 is sucked through air inlet 115 and is directed towards the interior of housing 101. After intake air 119 passes through the air inlet 115, intake air 119 contacts filter elements 111 and 113 arranged along longitudinal centerline 129 of housing 101. Proximal bases 205 and 207 of the filter elements are precisely sealed with flange 201 to prevent air leakage. Filter elements 111 and 113 may filter any particulates from intake air 119 and then intake air 119 may be directed out of housing 101 through air outlet 117. Accordingly, particulates may be filtered out of the interior of housing 101 when the intake air reaches air outlet 117.

In one instance, proximal bases 205 and 207 of filter elements 111 and 113, respectively, are shaped to couple directly to the same flange 201. The coupling of these proximal bases 205, 207 to the flange 201 facilitates a simple press fit connection. For example, filter elements 111 and 113 may be inserted along arrows 250 (FIG. 3) within housing 101 from the opening of the second

end wall 109. The bases of these filter elements are then sealed to flange 201 with minimal force, e.g., coupling surface 236 of the proximal base 205 is sealed to the external sidewall of flange 201, and coupling surface 245 of the proximal base 207 is sealed to the internal sidewall of flange 201. The coupling provides
5 for a snap-fit that can provide a physical sensation and/or audible sensation indicating a proper coupling of the filter elements 111, 113 on filter housing 101.

The filter system 100 of the present disclosure may provide a larger sealing surface for the filter elements and the housing. One or more embodiments of this disclosure may prevent a mixture of air that flows through
10 the center of first filter element 111 and air that flows around second filter element 113. One or more embodiments of this disclosure may facilitate a sturdy coupling that helps prevent displacement of filter elements during engine operation. One or more embodiments of this disclosure may provide accurate sealing of the filters elements to the housing with minimal compressive forces.
15 One or more embodiments of this disclosure may provide a single flange for coupling a plurality of filter elements, thereby making the coupling process less complicated.

It will be apparent to those skilled in the art that various modifications and variations can be made to the disclosed method and system
20 without departing from the scope of the disclosure. Other embodiments of the method and system will be apparent to those skilled in the art from consideration of the specification and practice of the apparatus and system disclosed herein. It is intended that the specification and examples be considered as exemplary only, with a true scope of the disclosure being indicated by the following claims and
25 their equivalents.

Claims

1. A filter assembly comprising:
a first filter element (111) having a first outlet end including a first opening;
5 a second filter element (113) having a second outlet end including a second opening; and
the first and second outlet ends of the first and second filter elements (111/113) include coupling surfaces (236/245) having complementary shapes.
10
2. The filter assembly according to claim 1, wherein the complementary shapes are located about the first opening of the first filter element (111), and located on a radially outer surface of the second outlet end of the second filter element (113).
15
3. The filter assembly according to any preceding claim, wherein at least one of the complementary shapes is a C-shape.
4. The filter assembly according to any preceding claim, wherein
20 the first and second filter elements (111/113) are cylindrical, and the first filter element (111) is sized to be located within the second filter element (113).
5. The filter assembly according to any preceding claim, wherein the first outlet end of the first filter element (111) is sized to be received within
25 the second opening of the second filter element (113).
6. The filter assembly according to according to any preceding claim, further comprising:
a housing (101) having an inlet (115), an outlet (117), a first end
30 (103), a second end (105), a sidewall (132) extending between the first end (103)

and the second end (105), a longitudinal centerline (129), and at least one flange (201) extending inside the housing (101); and
the first filter element (111) and the second filter element (113) located inside the housing (101), wherein the coupling surfaces (236/245) couple
5 directly to the at least one flange (201).

7. The filter assembly according to according to any preceding claim, wherein the first and second outlet ends of the first filter element (111) and the second filter element (113) are shaped to provide a snap-fit coupling with the
10 at least one flange (201).

8. The filter assembly according to according to any preceding claim, wherein the first and second outlet ends of the first filter element (111) and the second filter element (113) are located on opposite sides of the at least one
15 flange (201).

9. The filter assembly according to according to any preceding claim, wherein the first and second outlet ends of the first filter element (111) and the second filter element (113) are coextensive in a proximal-distal direction.
20

10. The filter assembly according to according to any preceding claim, wherein the at least one flange (201) is a single annular flange.

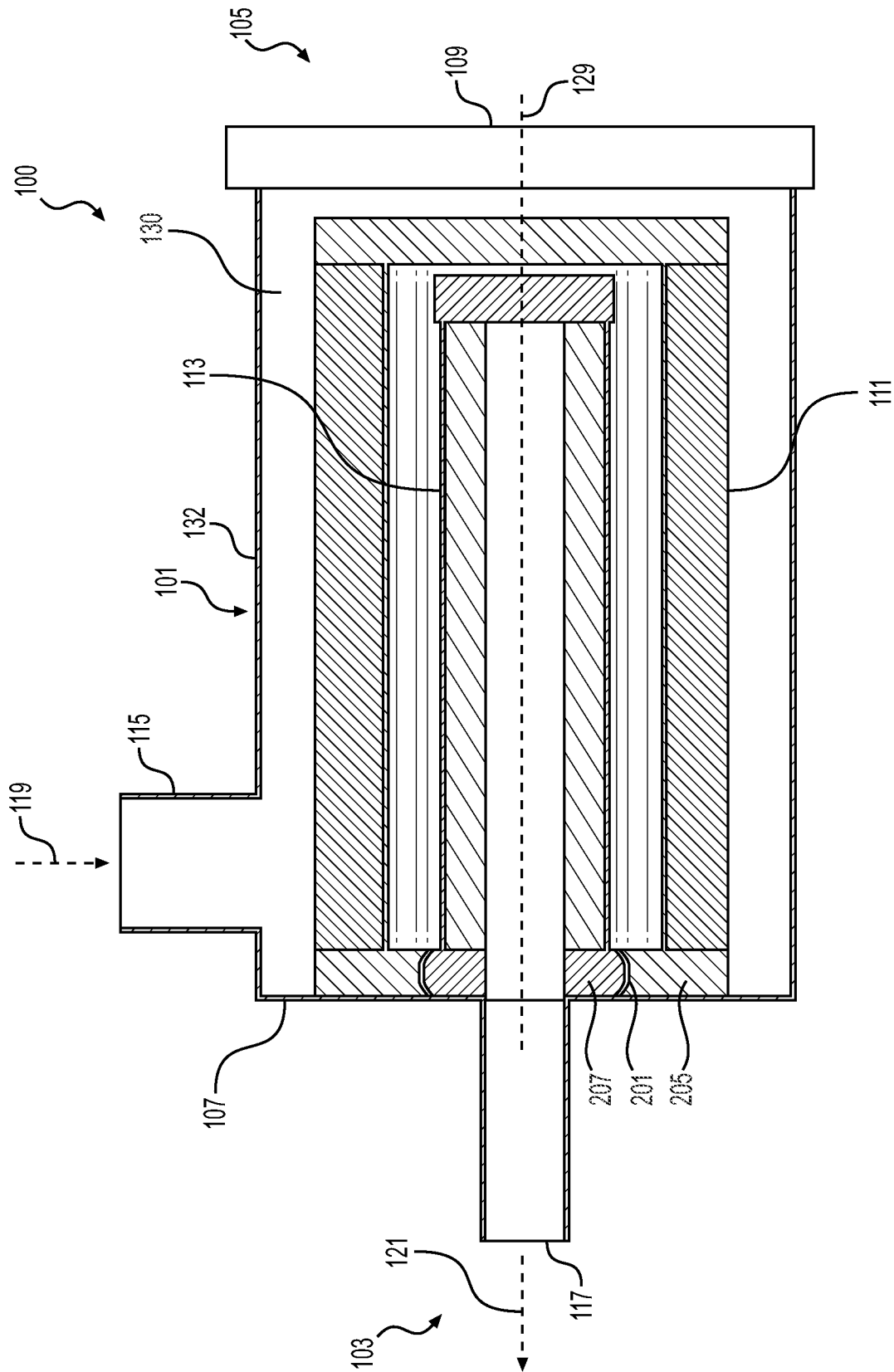

FIG. 1

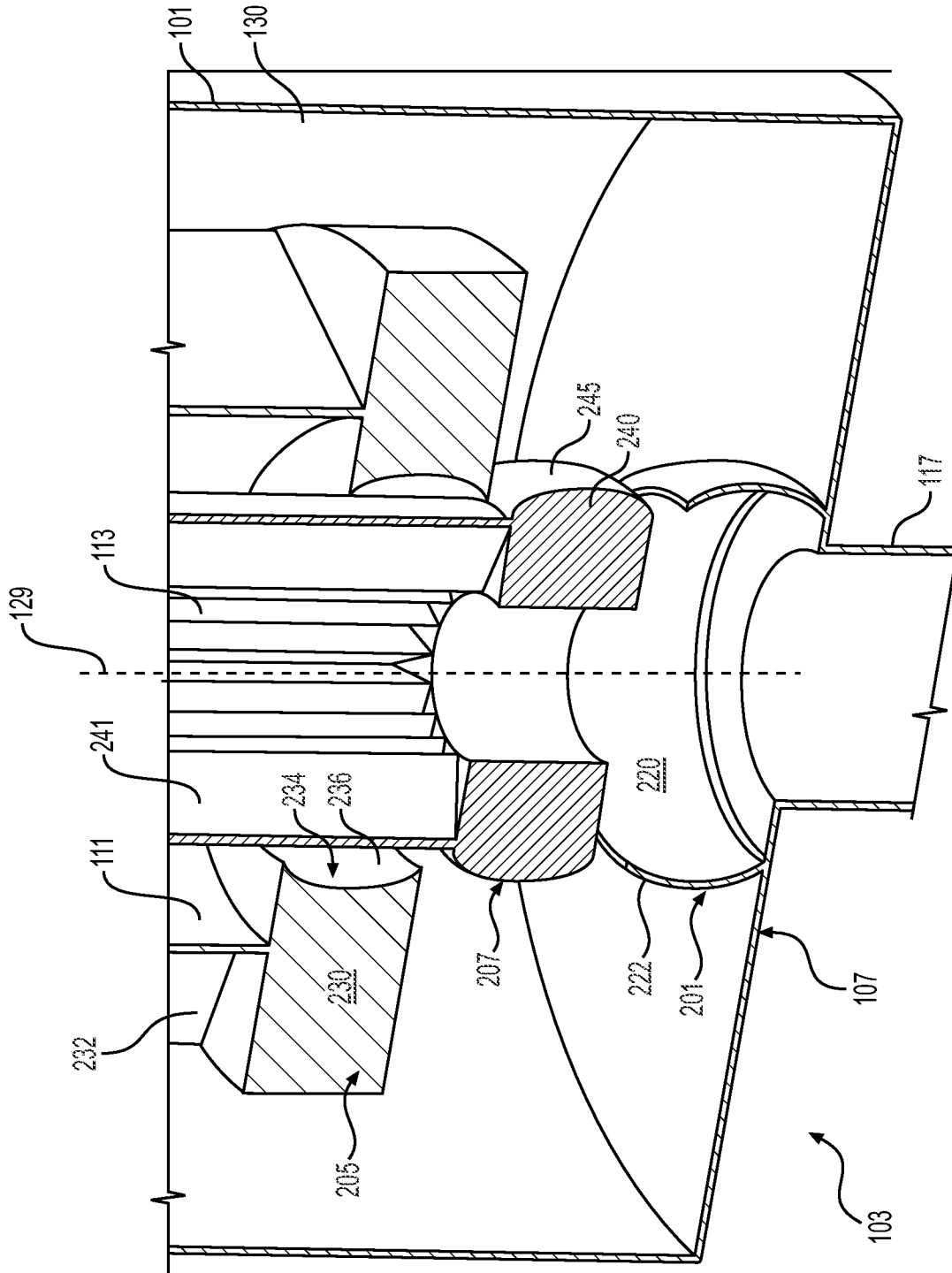

FIG. 2

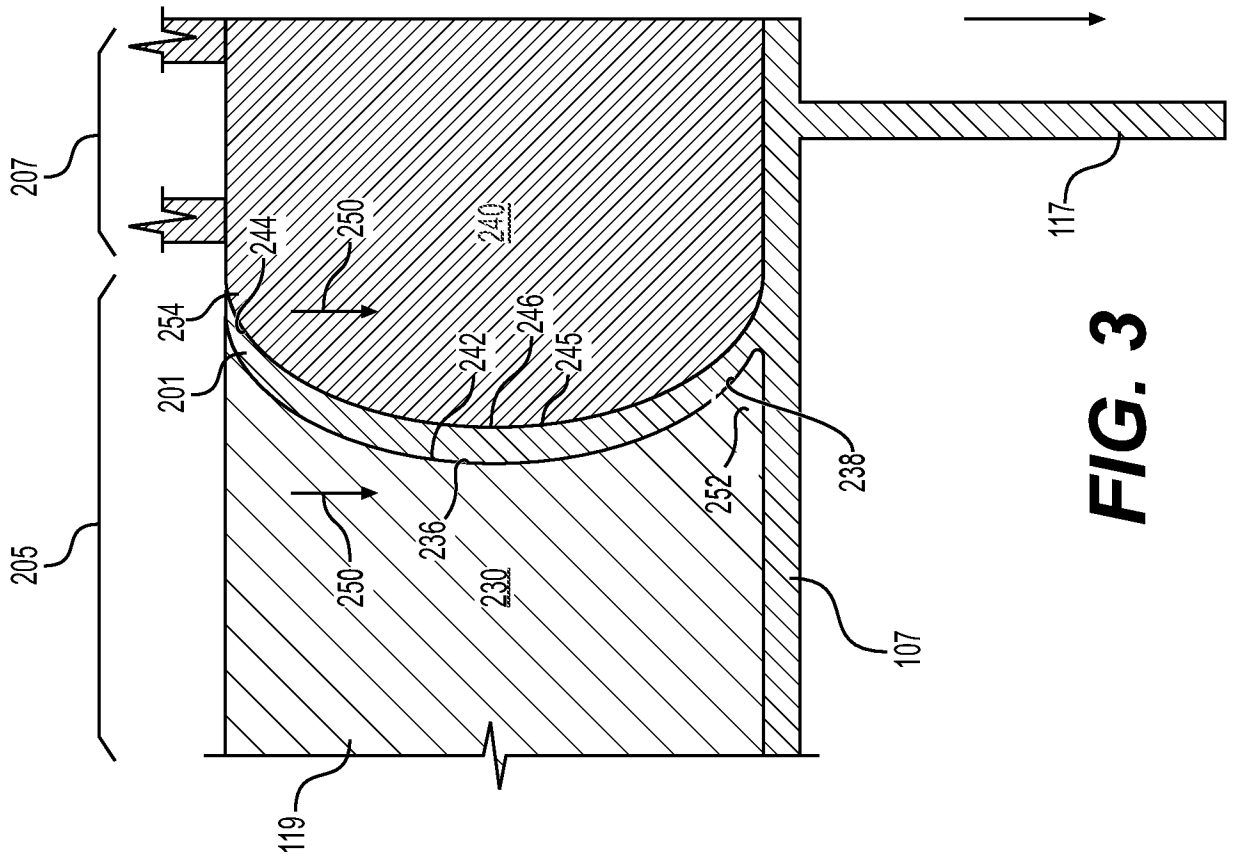

FIG. 3

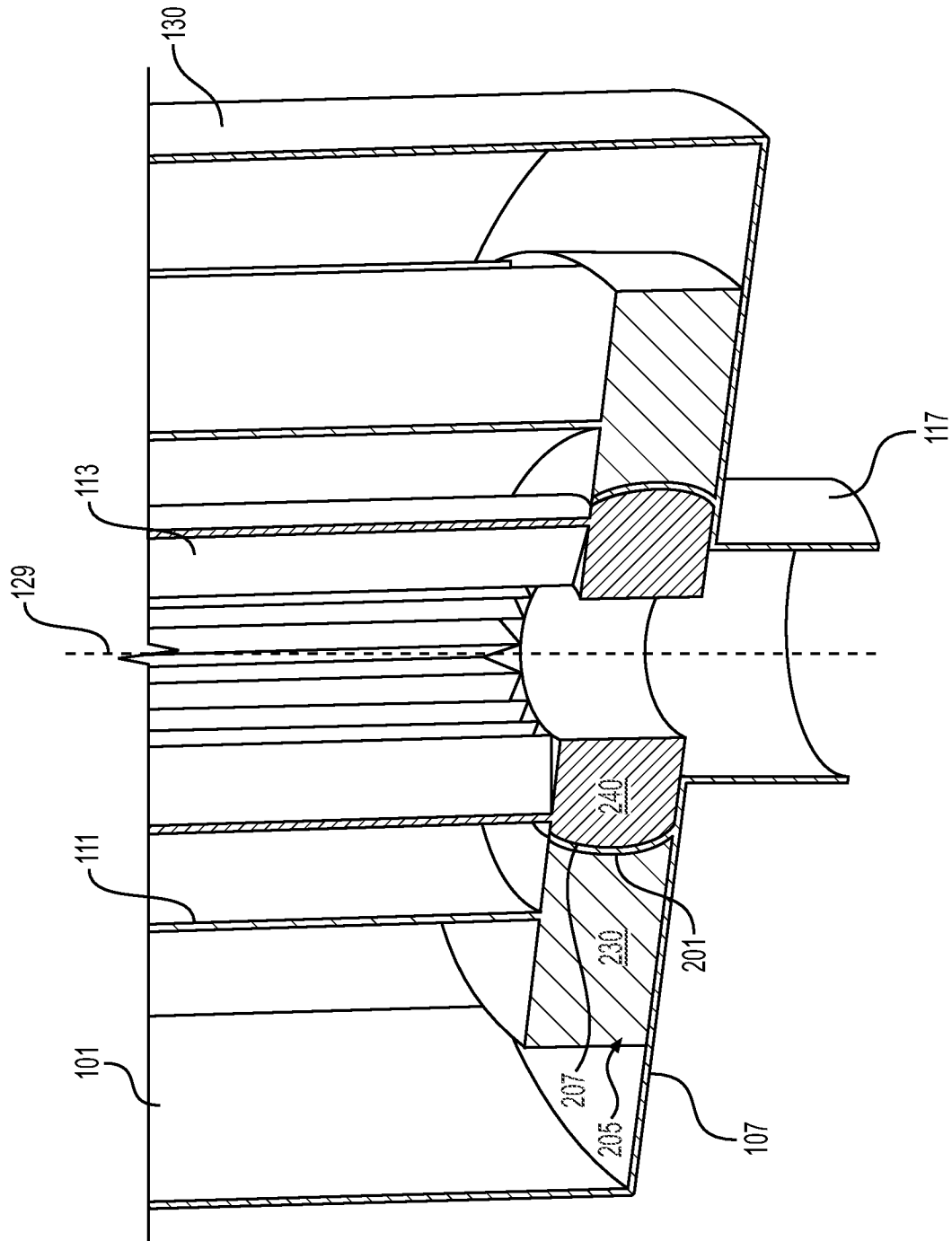

FIG. 4

INTERNATIONAL SEARCH REPORT

International application No
PCT/US2022/077561

A. CLASSIFICATION OF SUBJECT MATTER
INV. F02M35/02 B01D46/00 B01D46/24 B01D46/64 F02M35/024
ADD.

According to International Patent Classification (IPC) or to both national classification and IPC

B. FIELDS SEARCHED
 Minimum documentation searched (classification system followed by classification symbols)
F02M B01D

Documentation searched other than minimum documentation to the extent that such documents are included in the fields searched

Electronic data base consulted during the international search (name of data base and, where practicable, search terms used)
EPO-Internal, WPI Data

C. DOCUMENTS CONSIDERED TO BE RELEVANT

Category*	Citation of document, with indication, where appropriate, of the relevant passages	Relevant to claim No.
X	US 10 717 033 B2 (MANN & HUMMEL GMBH [DE]) 21 July 2020 (2020-07-21) abstract figures 1-4 column 7	1-10
X	----- US 2020/406181 A1 (CORVEC RONAN [FR] ET AL) 31 December 2020 (2020-12-31) abstract figures 1-6 paragraph [0025] - paragraph [0043]	1-10
X	----- EP 3 756 746 A1 (MANN & HUMMEL GMBH [DE]) 30 December 2020 (2020-12-30) abstract figures 1-27 paragraph [0035] - paragraph [0072]	1-6,8-10
	----- -/--	

Further documents are listed in the continuation of Box C. See patent family annex.

* Special categories of cited documents :

<p>"A" document defining the general state of the art which is not considered to be of particular relevance</p> <p>"E" earlier application or patent but published on or after the international filing date</p> <p>"L" document which may throw doubts on priority claim(s) or which is cited to establish the publication date of another citation or other special reason (as specified)</p> <p>"O" document referring to an oral disclosure, use, exhibition or other means</p> <p>"P" document published prior to the international filing date but later than the priority date claimed</p>	<p>"T" later document published after the international filing date or priority date and not in conflict with the application but cited to understand the principle or theory underlying the invention</p> <p>"X" document of particular relevance; the claimed invention cannot be considered novel or cannot be considered to involve an inventive step when the document is taken alone</p> <p>"Y" document of particular relevance; the claimed invention cannot be considered to involve an inventive step when the document is combined with one or more other such documents, such combination being obvious to a person skilled in the art</p> <p>"&" document member of the same patent family</p>
---	---

Date of the actual completion of the international search 18 January 2023	Date of mailing of the international search report 25/01/2023
---	---

Name and mailing address of the ISA/ European Patent Office, P.B. 5818 Patentlaan 2 NL - 2280 HV Rijswijk Tel. (+31-70) 340-2040, Fax: (+31-70) 340-3016	Authorized officer Juvenelle, Cyril
--	---

INTERNATIONAL SEARCH REPORT

International application No
PCT/US2022/077561

C(Continuation). DOCUMENTS CONSIDERED TO BE RELEVANT		
Category*	Citation of document, with indication, where appropriate, of the relevant passages	Relevant to claim No.
X	WO 2006/026241 A1 (DONALDSON CO INC [US]; SCOTT JAMES R [US] ET AL.) 9 March 2006 (2006-03-09) abstract figure 34 page 46 - page 51 -----	1-6, 8-10
X	EP 3 231 498 A1 (MANN & HUMMEL GMBH [DE]) 18 October 2017 (2017-10-18) abstract figures 1-7 paragraph [0034] - paragraph [0047] -----	1-5, 9

INTERNATIONAL SEARCH REPORT

Information on patent family members

International application No PCT/US2022/077561
--

Patent document cited in search report	Publication date	Patent family member(s)	Publication date	
US 10717033	B2	21-07-2020	CN 105935526 A	14-09-2016
			CN 107405558 A	28-11-2017
			DE 102016002059 A1	08-09-2016
			DE 112016001020 A5	23-11-2017
			EP 3265206 A1	10-01-2018
			EP 3957380 A1	23-02-2022
			ES 2900484 T3	17-03-2022
			US 2016256813 A1	08-09-2016
			US 2017361261 A1	21-12-2017
			US 2020391152 A1	17-12-2020
			WO 2016139085 A1	09-09-2016

US 2020406181	A1	31-12-2020	CN 111867702 A	30-10-2020
			DE 112019001132 T5	26-11-2020
			FR 3078490 A1	06-09-2019
			US 2020406181 A1	31-12-2020
			WO 2019170579 A1	12-09-2019

EP 3756746	A1	30-12-2020	BR 112021023803 A2	04-01-2022
			CN 114007721 A	01-02-2022
			EP 3756746 A1	30-12-2020
			EP 3990153 A1	04-05-2022
			JP 2022538255 A	01-09-2022
			KR 20220024188 A	03-03-2022
			US 2022118397 A1	21-04-2022
			WO 2020260159 A1	30-12-2020

WO 2006026241	A1	09-03-2006	AT 492324 T	15-01-2011
			BR PI0514607 A	17-06-2008
			CN 101048215 A	03-10-2007
			CN 102350151 A	15-02-2012
			EP 1789159 A1	30-05-2007
			ES 2358433 T3	10-05-2011
			JP 2008510932 A	10-04-2008
			US 2008190082 A1	14-08-2008
			US 2012272633 A1	01-11-2012
			US 2013199138 A1	08-08-2013
			US 2015068173 A1	12-03-2015
			US 2015251123 A1	10-09-2015
			WO 2006026241 A1	09-03-2006

EP 3231498	A1	18-10-2017	BR 102017007226 A2	17-10-2017
			CN 107281793 A	24-10-2017
			DE 102016004315 A1	12-10-2017
			EP 3231498 A1	18-10-2017
			ES 2794577 T3	18-11-2020
			PL 3231498 T3	21-09-2020
			US 2017291129 A1	12-10-2017
