



US 20080185039A1

(19) **United States**
(12) **Patent Application Publication**
Chan

(10) **Pub. No.: US 2008/0185039 A1**
(43) **Pub. Date: Aug. 7, 2008**

(54) **CONDUCTOR FABRICATION FOR OPTICAL ELEMENT**

Publication Classification

(76) Inventor: **Hing Wah Chan**, San Jose, CA (US)

(51) **Int. Cl.**
H01L 31/00 (2006.01)
G03C 5/00 (2006.01)
(52) **U.S. Cl.** **136/256; 430/314; 430/319**

Correspondence Address:
BUCKLEY, MASCHOFF & TALWALKAR LLC
50 LOCUST AVENUE
NEW CANAAN, CT 06840

(57) **ABSTRACT**

A system may provide an optical element including conductive material deposited on the optical element using a thick film process, dielectric material disposed on the conductive material and defining an aperture created using photolithography, the aperture exposing a portion of the conductive material, and a solar cell comprising an electrical contact coupled to the exposed portion of the conductive material.

(21) Appl. No.: **11/782,376**

(22) Filed: **Jul. 24, 2007**

Some aspects provide deposition of conductive material on an optical element using a thick film process, deposition of dielectric material on the conductive material, creation of an aperture in the dielectric material using photolithography to expose a portion of the conductive material, and coupling of an electrical contact of a solar cell to the exposed portion of the conductive material.

Related U.S. Application Data

(60) Provisional application No. 60/899,150, filed on Feb. 2, 2007.

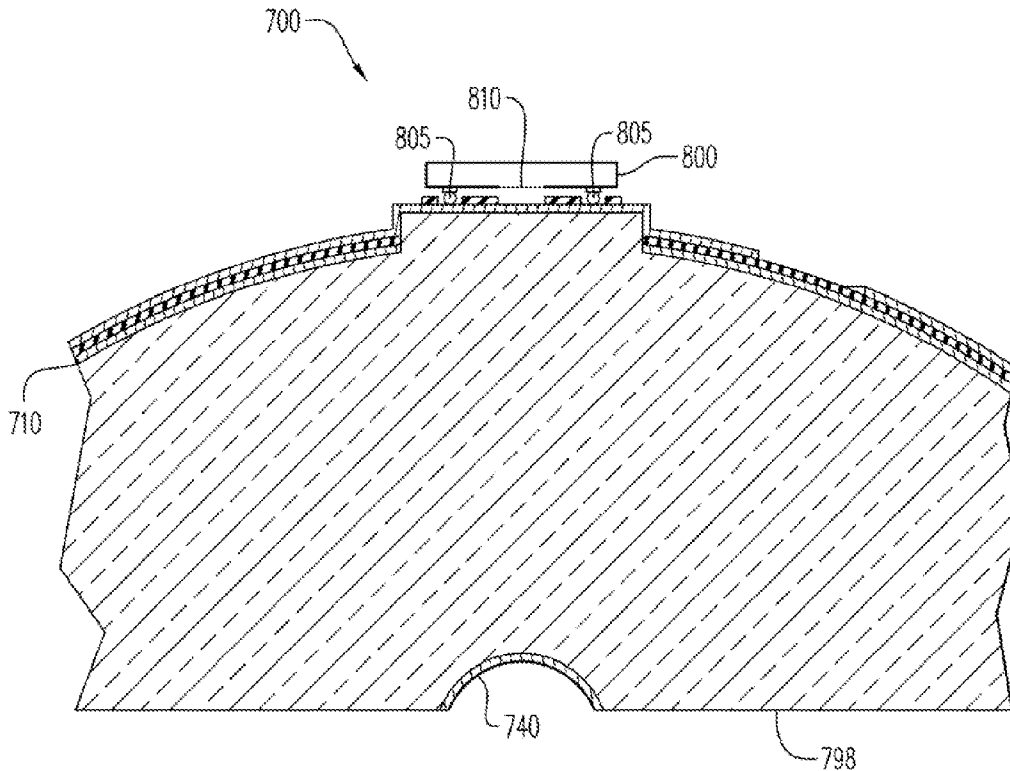

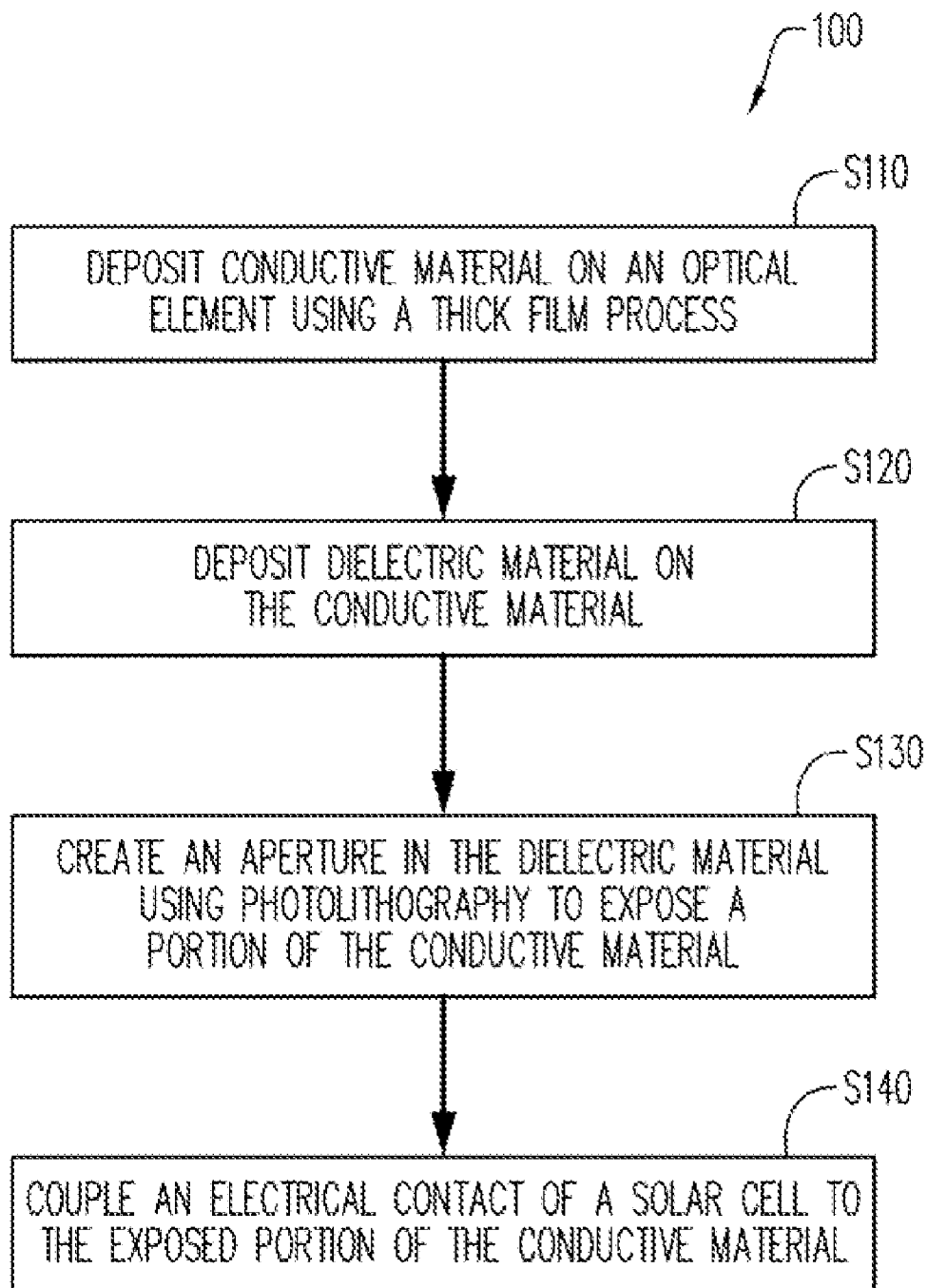
**FIG. 1**

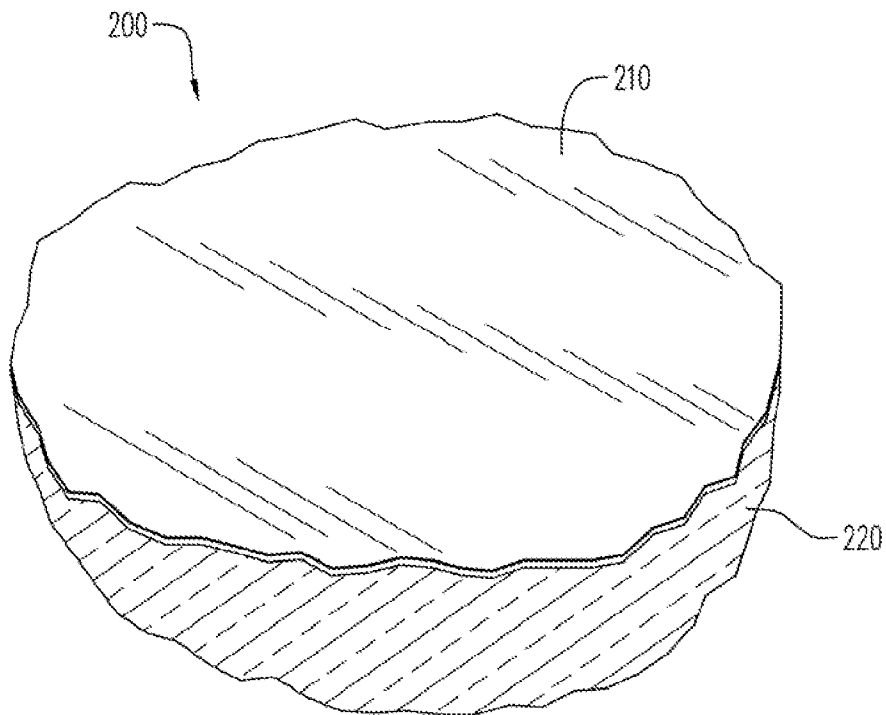

FIG. 2A

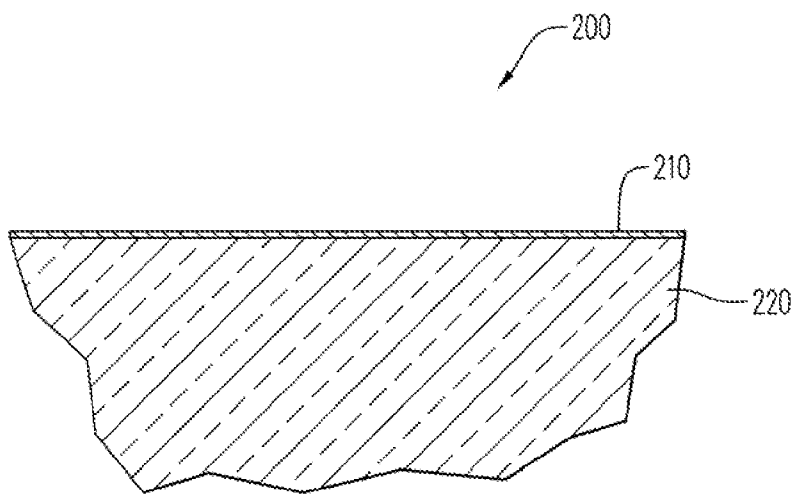

FIG. 2B

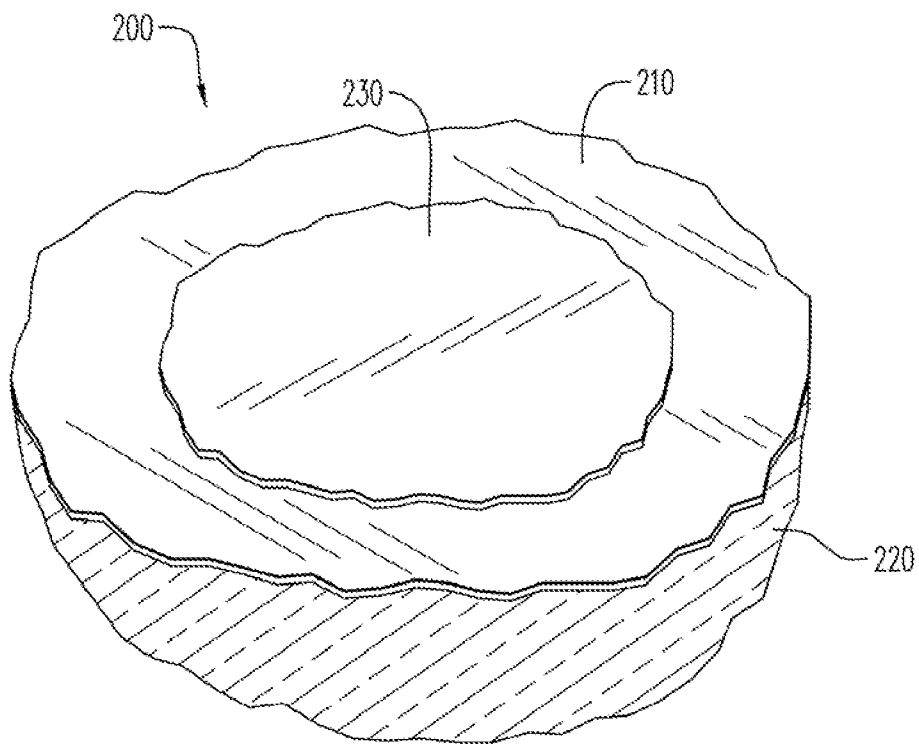

FIG. 3A

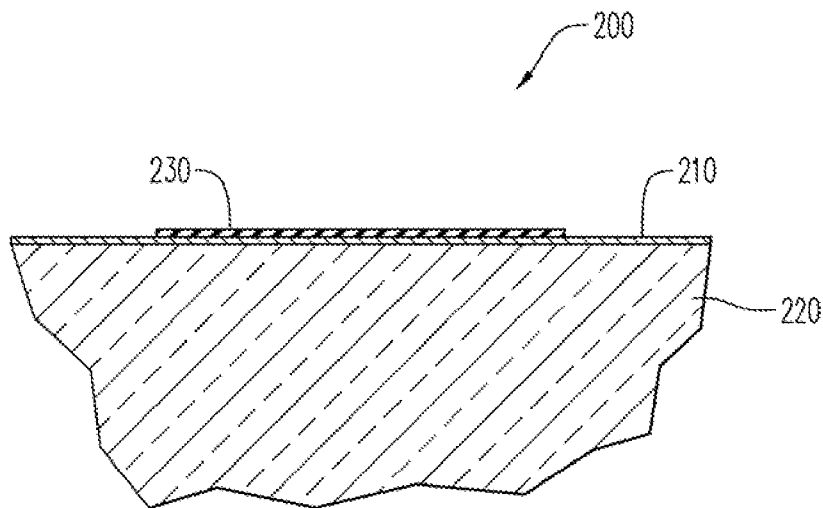

FIG. 3B

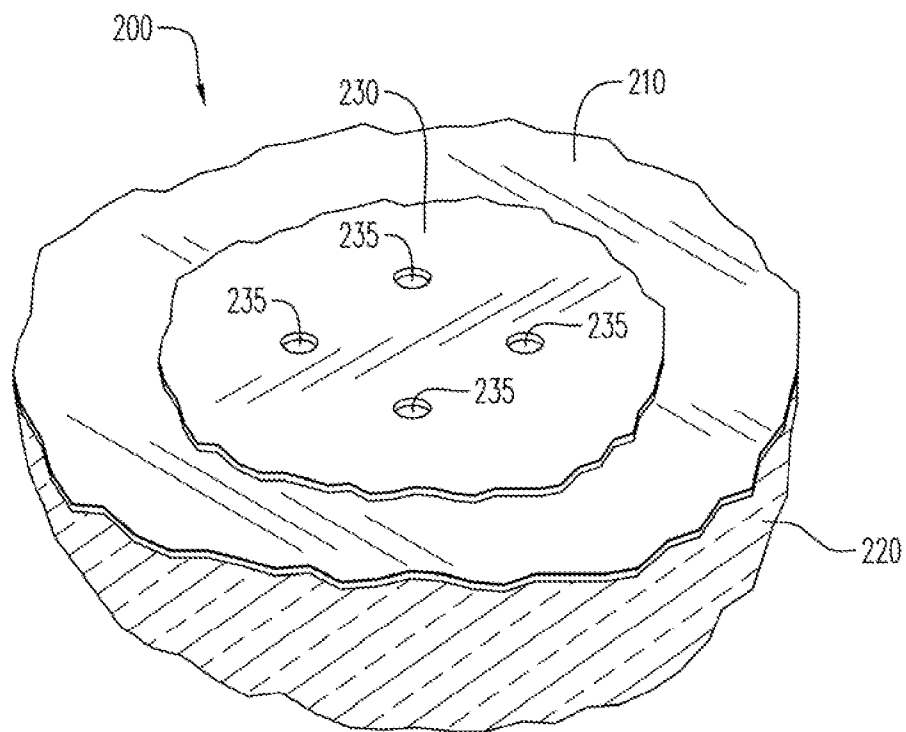

FIG. 4A

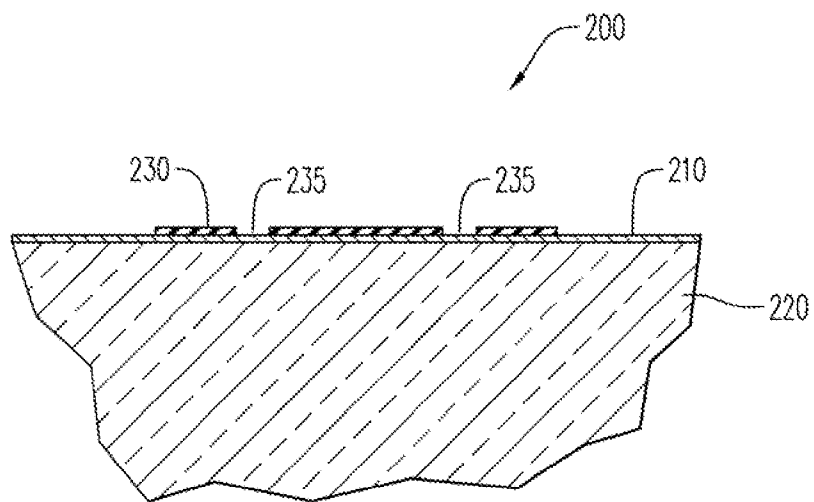

FIG. 4B

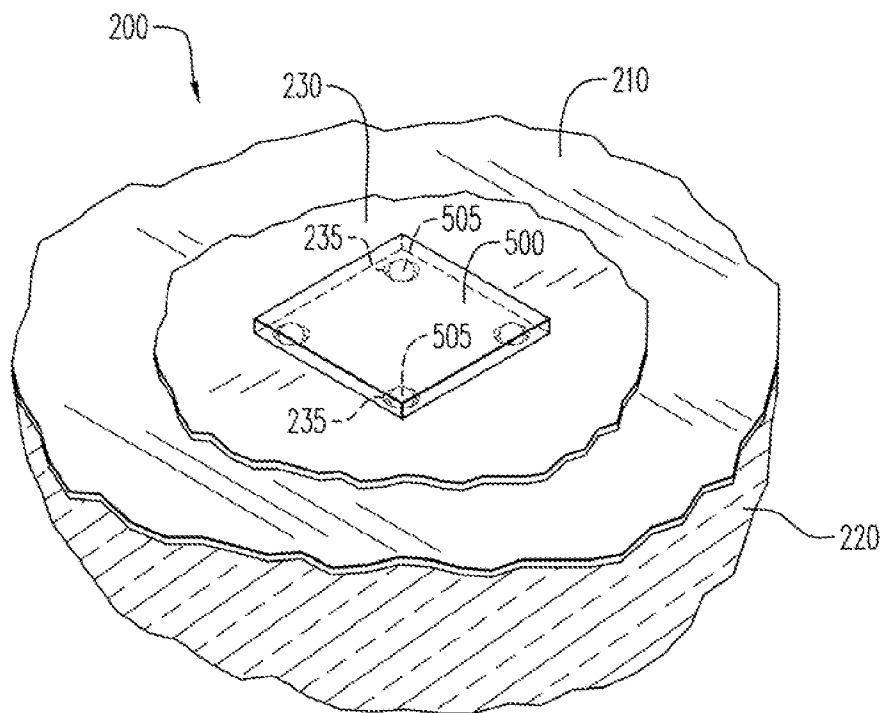

FIG. 5A

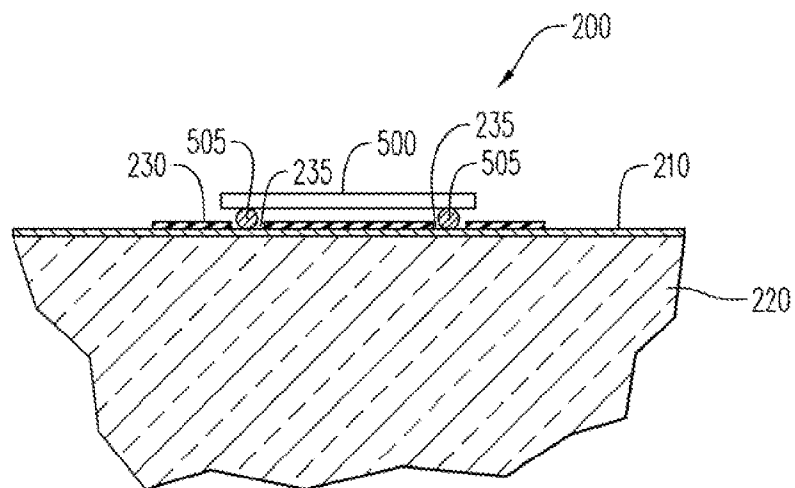

FIG. 5B

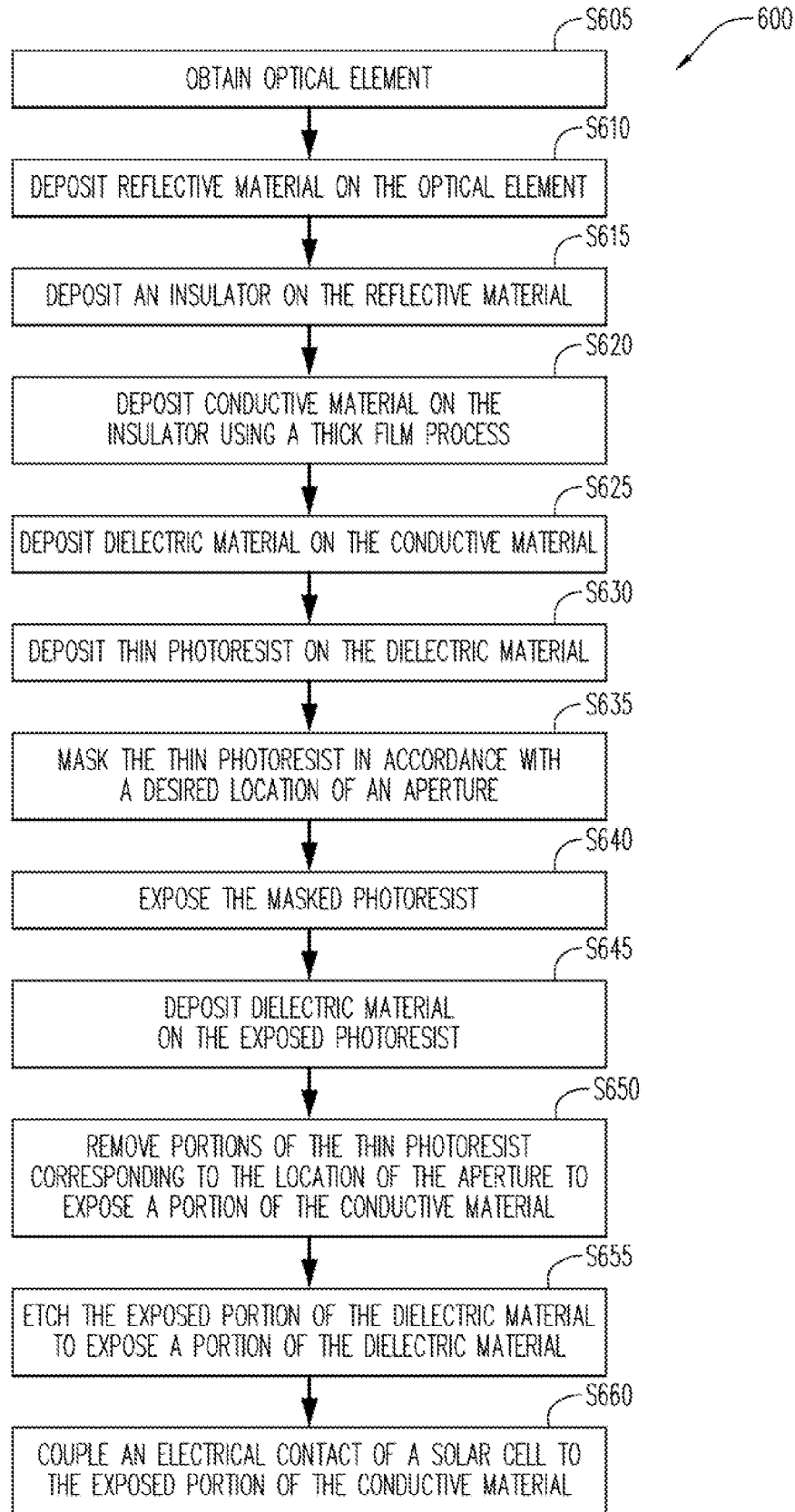

FIG. 6

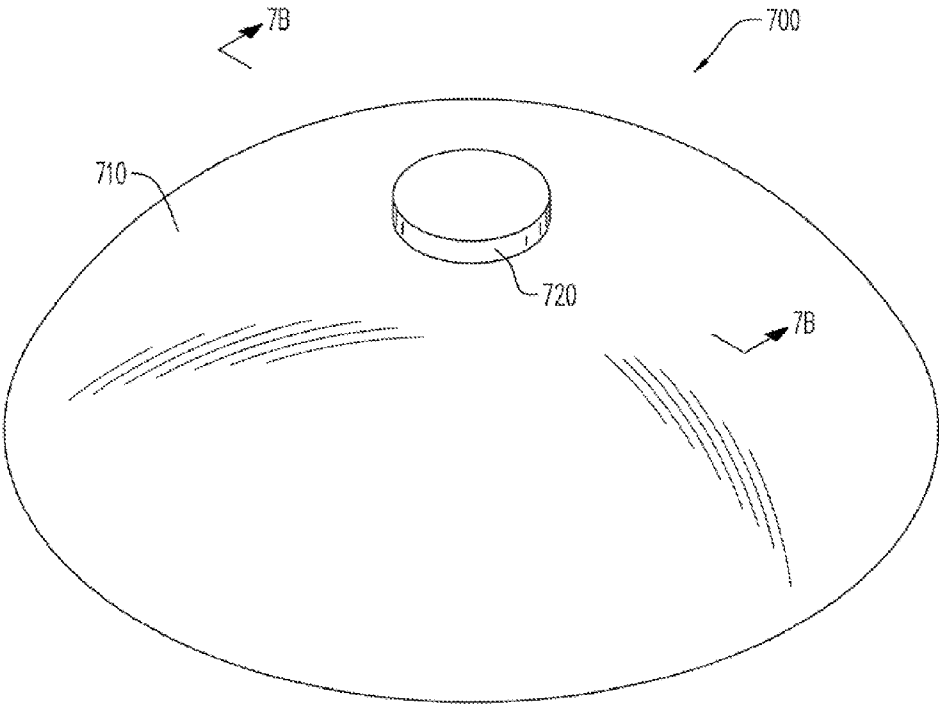

FIG. 7A

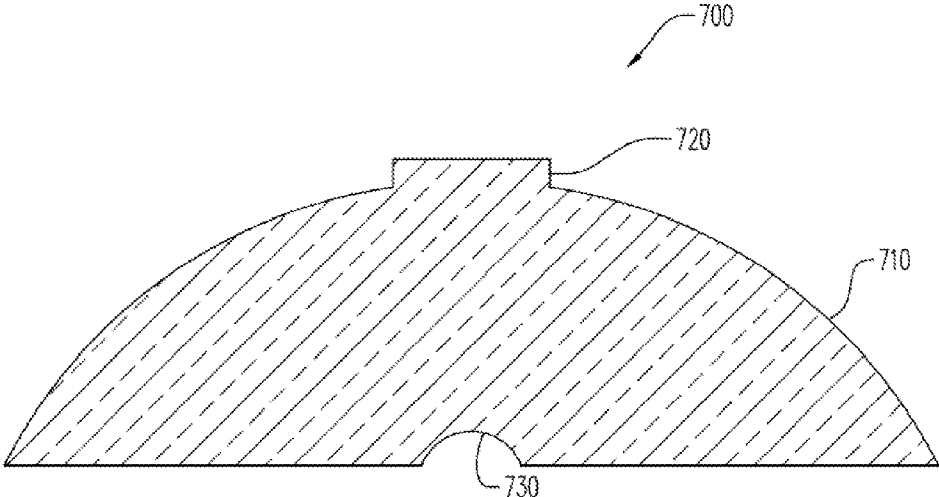

FIG. 7B

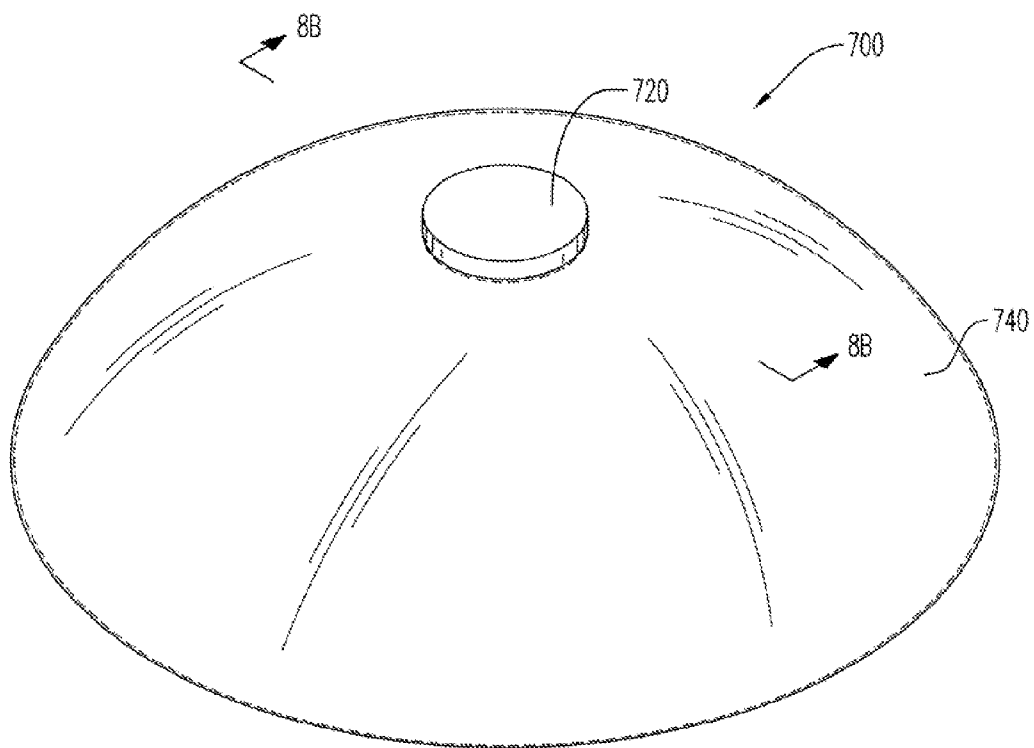

FIG. 8A

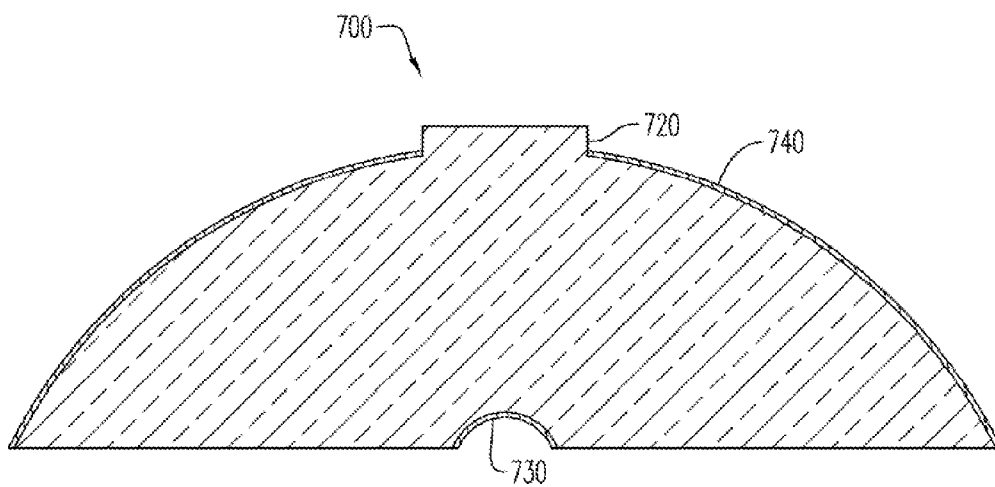

FIG. 8B

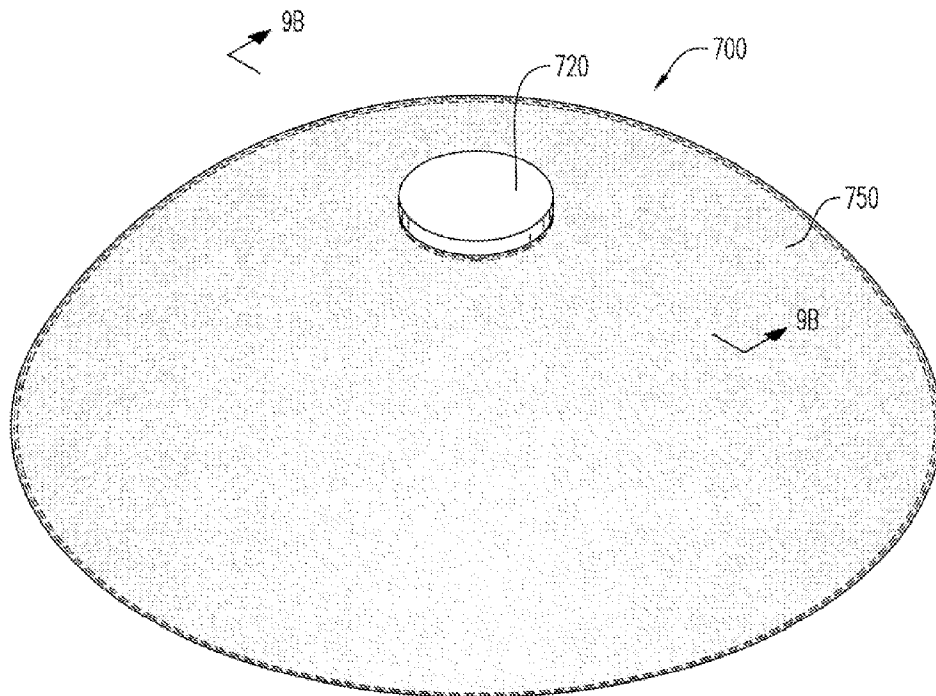

FIG. 9A

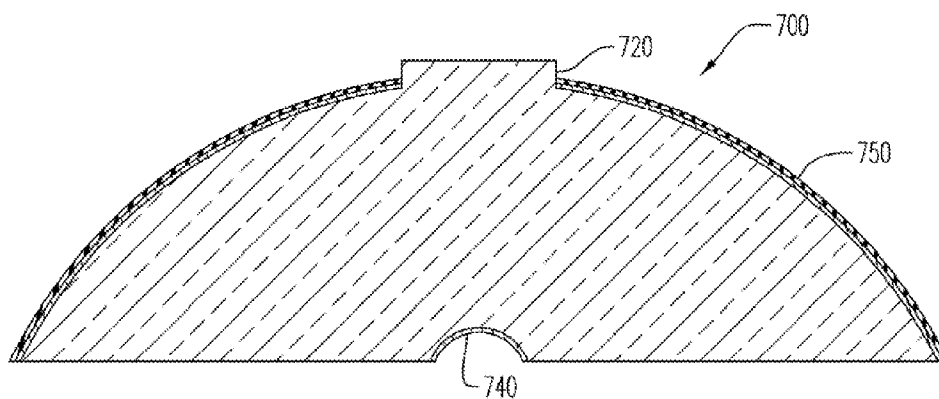

FIG. 9B

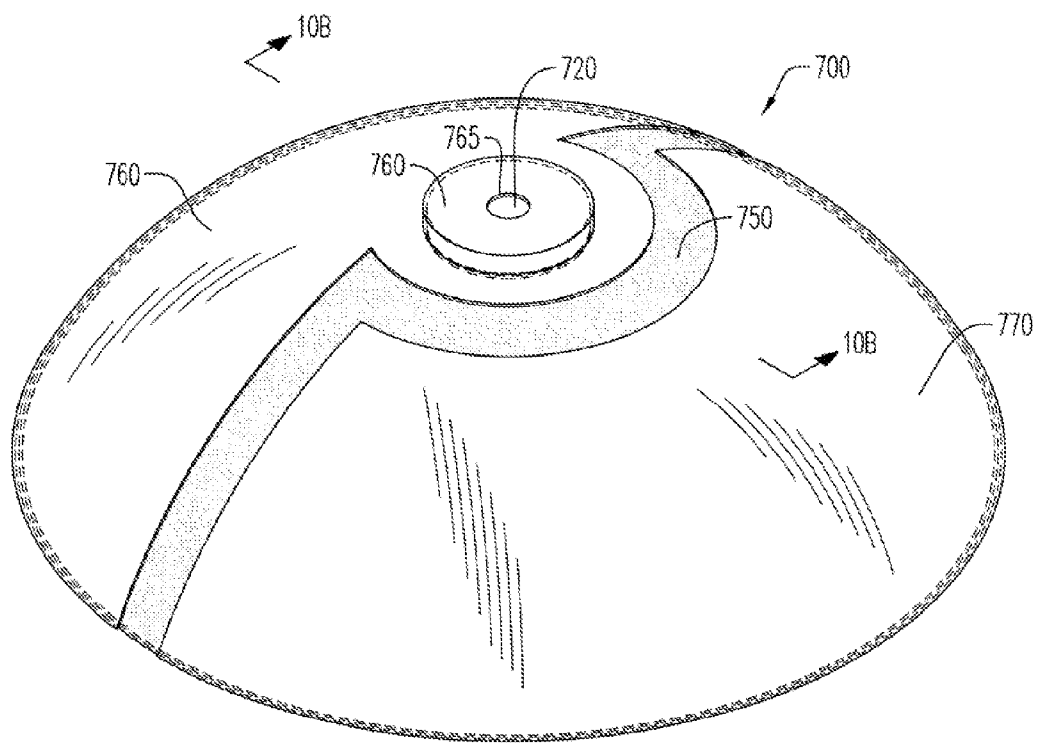

FIG. 10A

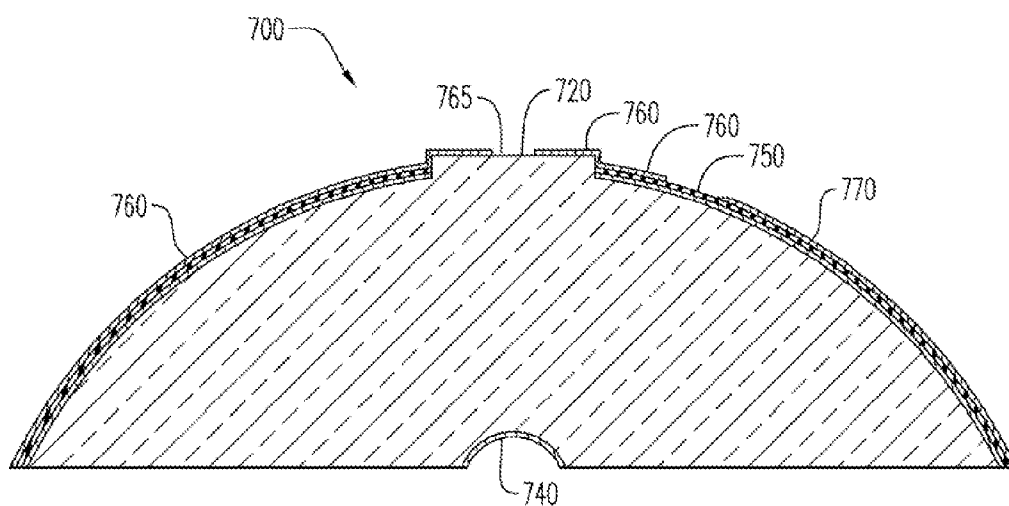

FIG. 10B

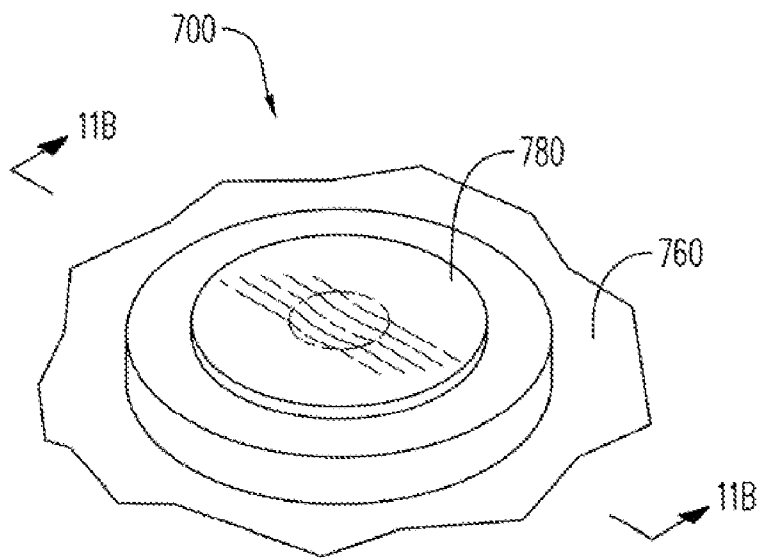

FIG. 11A

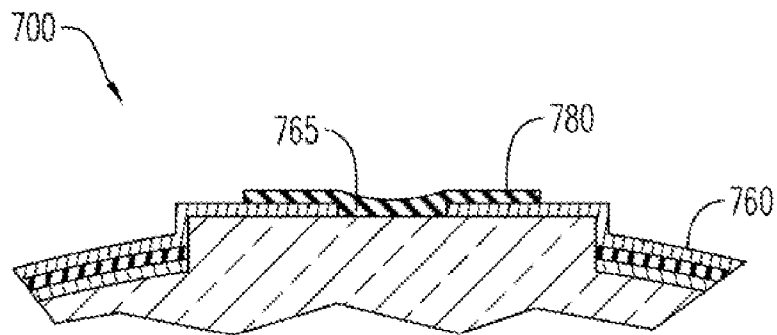

FIG. 11B

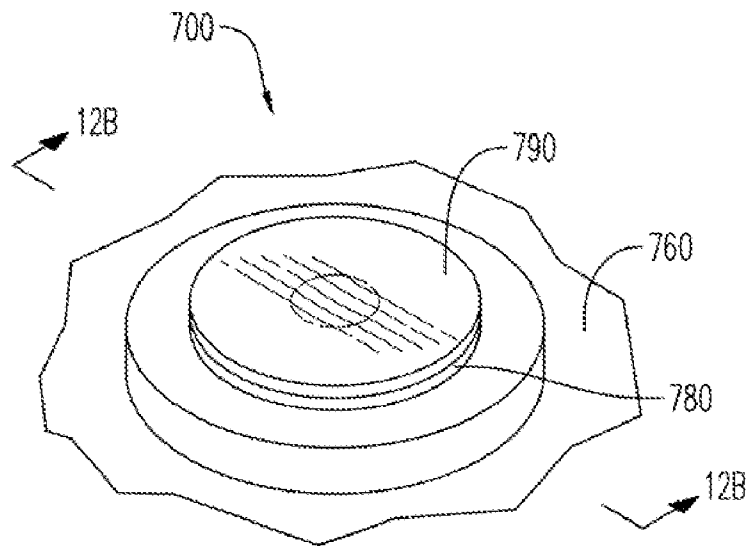

FIG. 12A

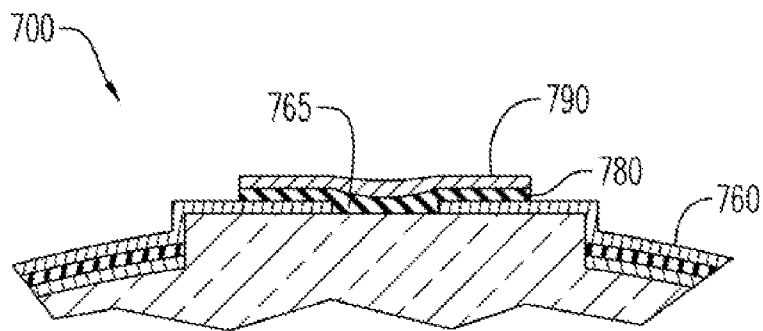

FIG. 12B

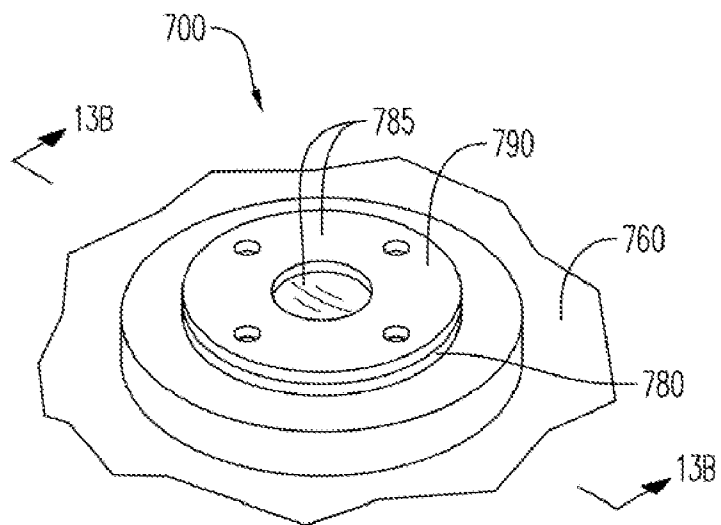

FIG. 13A

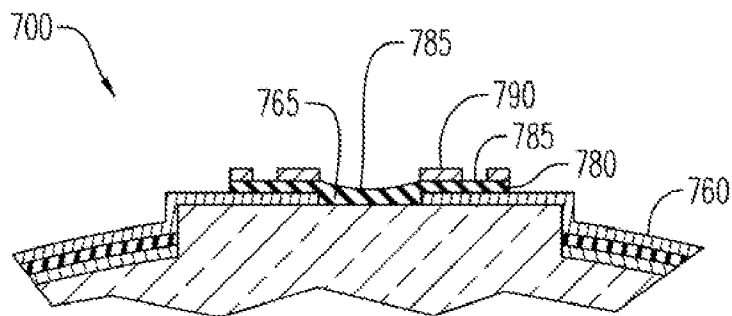

FIG. 13B

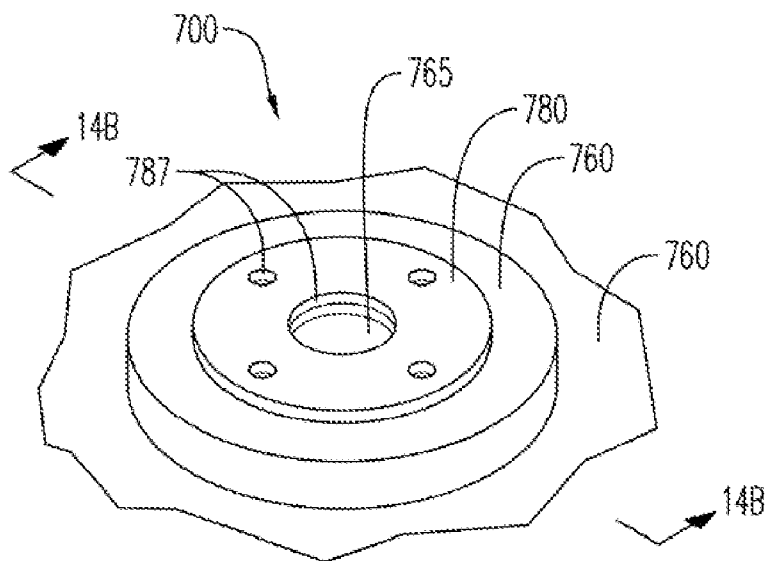

FIG. 14A

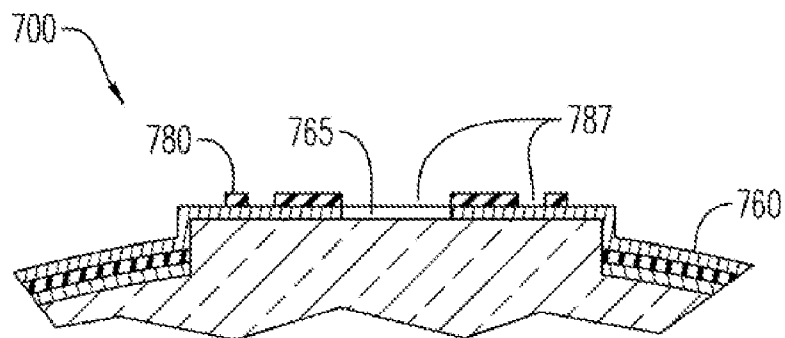

FIG. 14B

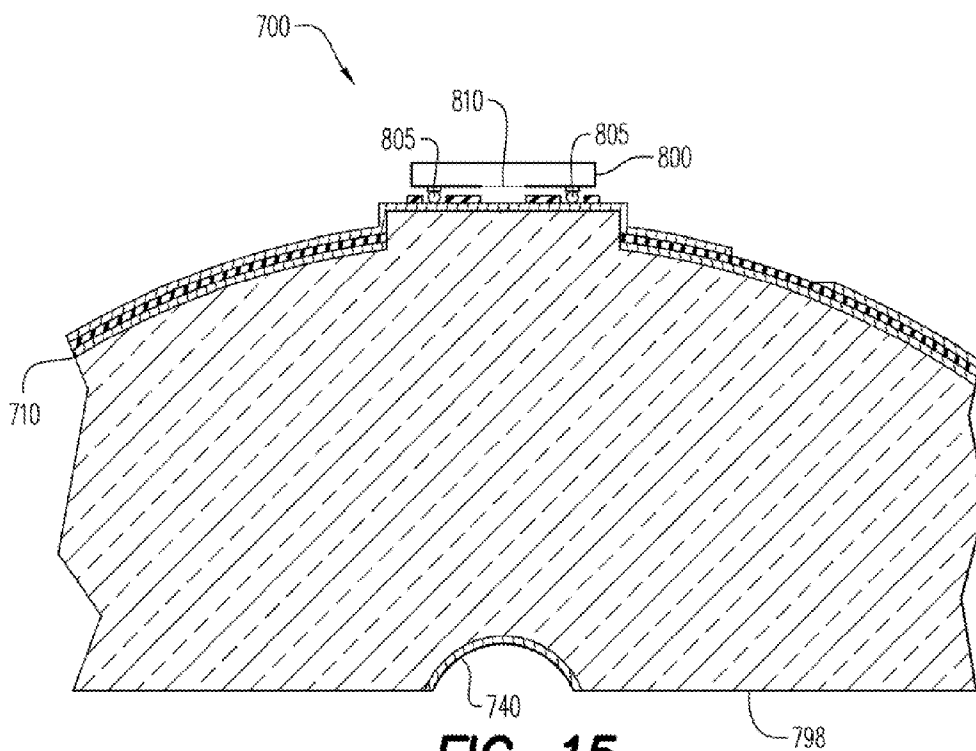

FIG. 15

CONDUCTOR FABRICATION FOR OPTICAL ELEMENT

CROSS-REFERENCE TO RELATED APPLICATIONS

[0001] The present application claims priority to U.S. Provisional Patent Application Ser. No. 60/899,150, filed on Feb. 2, 2007 and entitled "Concentrated Photovoltaic Energy Designs", the contents of which are incorporated herein by reference for all purposes.

BACKGROUND

[0002] 1. Field

[0003] Some embodiments generally relate to electrical systems incorporating one or more optical elements. More specifically, embodiments may relate to an optical element efficiently adapted for interconnection to electrical devices.

[0004] 2. Brief Description

[0005] In some conventional devices, an optical element (e.g., a lens) may include metal traces for interconnection to an electrical circuit. The metal traces may be fabricated on and/or within the optical element by any of several known techniques. Using thin film lithographic techniques, metal is evaporated or sputtered onto an optical element within a vacuum, photoresist is deposited on the metal and patterned via masking and UV exposure, and areas of the metal are etched in accordance with the photoresist pattern. Thin film lithography may provide geometrically accurate traces but entails significant expense.

[0006] Thick film techniques may alternatively be used for fabricating metal traces onto an optical element. In accordance with one thick film technique, a stencil is placed on an optical element and a metal paste is applied to the stencil and the optical element. The stencil is removed and the paste is heated to form a solid metal material. Fabrication using thick film techniques is typically less expensive than corresponding thin film-based fabrication, but cannot provide tolerances required by certain applications.

[0007] What is needed is a system to efficiently fabricate metal traces on an optical element. Such a system may provide the accuracy of thin film lithography where needed and cost advantages of thick film fabrication where such accuracy is not required.

SUMMARY

[0008] To address at least the foregoing, some aspects provide a method, means and/or process steps to deposit conductive material on an optical element using a thick film process, deposit dielectric material on the conductive material, create an aperture in the dielectric material using photolithography to expose a portion of the conductive material, and couple an electrical contact of a solar cell to the exposed portion of the conductive material.

[0009] In some aspects, the conductive material deposited on the optical element defines a window from which light may pass out of the optical element, and the electrical contact of the solar cell is coupled to the exposed portion of the conductive material such that an optically-active area of the solar cell is aligned with the window. Deposition of the conductive material on the optical element in some aspects includes placing a stencil on the optical element and spraying molten conductive material on the stencil and the optical element.

[0010] According to certain aspects, the dielectric material comprises thick photoresist and creation of the aperture includes masking the thick photoresist in accordance with a location of the aperture, exposing the masked photoresist, and removing portions of the thick photoresist corresponding to the location of the aperture. In other aspects, creation of the aperture includes deposition of thin photoresist on the dielectric material, masking of the thin photoresist in accordance with a location of the aperture, exposure of the masked photoresist, removal of portions of the thin photoresist corresponding to the location of the aperture, and etching away of portions of the dielectric material corresponding to the location of the aperture.

[0011] Still other aspects include creation of the aperture by depositing thin photoresist on the conductive material, masking the thin photoresist in accordance with a location of the aperture, exposing the masked photoresist, and removing portions of the thin photoresist corresponding to the location of the aperture. Deposition of the dielectric material may therefore comprise depositing the dielectric material on the thin photoresist.

[0012] Some aspects provide an optical element including conductive material deposited on the optical element using a thick film process, dielectric material disposed on the conductive material and defining an aperture created using photolithography, the aperture exposing a portion of the conductive material, and a solar cell comprising an electrical contact coupled to the exposed portion of the conductive material. The dielectric material may include thick photoresist, and the aperture may have been created by masking the thick photoresist in accordance with a location of the aperture, exposing the masked photoresist, and removing portions of the thick photoresist corresponding to the location of the aperture.

[0013] Alternatively, the aperture may have been created by depositing thin photoresist on the dielectric material, masking the thin photoresist in accordance with a location of the aperture, exposing the masked photoresist, removing portions of the thin photoresist corresponding to the location of the aperture, and etching away portions of the dielectric material corresponding to the location of the aperture.

[0014] In yet other aspects, the aperture may have been created by depositing thin photoresist on the conductive material, masking the thin photoresist in accordance with a location of the aperture, exposing the masked photoresist, and removing portions of the thin photoresist corresponding to the location of the aperture. Deposition of the dielectric material may therefore include depositing the dielectric material on the thin photoresist.

[0015] According to some aspects, the conductive material deposited on the optical element defines a window from which light may pass out of the optical element, and the electrical contact of the solar cell is coupled to the exposed portion of the conductive material such that an optically-active area of the solar cell is aligned with the window.

[0016] Some aspects may also provide a reflective material deposited on the optical element and an electrical isolator deposited on the reflective material, wherein the conductive material is deposited on the electrical isolator.

[0017] The claims are not limited to the disclosed embodiments, however, as those in the art can readily adapt the description herein to create other embodiments and applications.

BRIEF DESCRIPTION OF THE DRAWINGS

[0018] The construction and usage of embodiments will become readily apparent from consideration of the following specification as illustrated in the accompanying drawings, in which like reference numerals designate like parts.

[0019] FIG. 1 is a flow diagram of a method according to some embodiments.

[0020] FIG. 2A is a perspective view of a portion of an optical element with conductive material disposed thereon according to some embodiments.

[0021] FIG. 2B is a cross-sectional view of a portion of an optical element with conductive material disposed thereon according to some embodiments.

[0022] FIG. 3A is a perspective view of a portion of an optical element with conductive material and dielectric material disposed thereon according to some embodiments.

[0023] FIG. 3B is a cross-sectional view of a portion of an optical element with conductive material and dielectric material disposed thereon according to some embodiments.

[0024] FIG. 4A is a perspective view of a portion of an optical element with conductive material and dielectric material defining apertures disposed thereon according to some embodiments.

[0025] FIG. 4B is a cross-sectional view of a portion of an optical element with conductive material and dielectric material defining apertures disposed thereon according to some embodiments.

[0026] FIG. 5 is a perspective view of a portion of an optical element with conductive material and dielectric material disposed thereon, and a solar cell with electrical contacts coupled to portions of the conductive material exposed by apertures defined by the dielectric material according to some embodiments.

[0027] FIG. 6 is a flow diagram of a method according to some embodiments.

[0028] FIG. 7A is a perspective view of a transparent optical element according to some embodiments.

[0029] FIG. 7B is a cross-sectional view of a transparent optical element according to some embodiments.

[0030] FIG. 8A is a perspective view of a transparent optical element with reflective material disposed thereon according to some embodiments.

[0031] FIG. 8B is a cross-sectional view of a transparent optical element with reflective material disposed thereon according to some embodiments.

[0032] FIG. 9A is a perspective view of an optical element with an electrical isolator disposed thereon according to some embodiments.

[0033] FIG. 9B is a cross-sectional view of an optical element with an electrical isolator disposed thereon according to some embodiments.

[0034] FIG. 10A is a perspective view of an optical element with conductive material disposed thereon according to some embodiments.

[0035] FIG. 10B is a cross-sectional view of an optical element with conductive material disposed thereon according to some embodiments.

[0036] FIG. 11A is a close-up perspective view of dielectric material applied to a pedestal of an optical element according to some embodiments.

[0037] FIG. 11B is a cross-sectional view of dielectric material applied to a pedestal of an optical element according to some embodiments.

[0038] FIG. 12A is a close-up perspective view of photoresist applied to dielectric material according to some embodiments.

[0039] FIG. 12B is a cross-sectional view of photoresist applied to dielectric material according to some embodiments.

[0040] FIG. 13A is a close-up perspective view of exposed and developed photoresist disposed on dielectric material according to some embodiments.

[0041] FIG. 13B is a cross-sectional view of exposed and developed photoresist disposed on dielectric material according to some embodiments.

[0042] FIG. 14A is a close-up perspective view of dielectric material defining apertures exposing conductive material on an optical element according to some embodiments.

[0043] FIG. 14B is a cross-sectional view of dielectric material defining apertures exposing conductive material on an optical element according to some embodiments.

[0044] FIG. 15 is a close-up perspective view of an optical element including a solar cell according to some embodiments.

DETAILED DESCRIPTION

[0045] The following description is provided to enable any person in the art to make and use the described embodiments and sets forth the best mode contemplated for carrying out some embodiments. Various modifications, however, will remain readily apparent to those in the art.

[0046] FIG. 1 is a flow diagram of process 100 according to some embodiments. Process 100 may be performed by any combination of machine, hardware, software and manual means.

[0047] Initially, at S110, conductive material is deposited on an optical element using a thick film process. The conductive material may comprise any combination of one or more currently- or hereafter-known conductors, including but not limited to copper, gold and nickel. According to some embodiments, the optical element may be configured to manipulate and/or pass desired wavelengths of light. The optical element may comprise any number of disparate materials and/or elements (e.g., lenses, reflective surfaces and optically-transparent portions).

[0048] The conductive material may be deposited at S110 by thermal spraying, paste deposition, or other thick film techniques. Thick film techniques may produce a layer of material that is less geometrically precise than a layer deposited using thin film techniques. However, thick film techniques may allow for inexpensive deposition of the conductive material while also satisfying relatively loose geometric tolerances that may be required of the conductive layer.

[0049] Thermal spraying the conductive material may include heating a powder of conductive material (e.g., copper) to a molten state and spraying the molten powder onto the optical element. The molten powder then cools on the optical element to produce a solid layer of conductive material. Paste-based thick film techniques may involve mixing metal powder and a carrier to create a paste and applying the paste to an optical element using pad printing, needles, screen printing, a roller and/or a squeegee tool. The optical element and paste are thereafter heated and cooled to form the solid layer of conductive material. In some embodiments, a stencil may be applied to the optical element before applying the

paste or spraying the molten powder onto the optical element. The conductive material is therefore deposited in a pattern defined by the stencil.

[0050] FIG. 2A is a perspective view of apparatus 200 according to some embodiments, and FIG. 2B is a cross-sectional view of apparatus 200 as shown in FIG. 2A. Apparatus 200 includes optical element 220 and conductive material 210 deposited thereon according to some embodiments of S110. FIGS. 2A and 2B show only a portion of apparatus 200 in order to illustrate that apparatus 200 may exhibit any suitable shape or size.

[0051] A thickness of material 210 on optical element 220 need not be as uniform as shown in FIG. 2B. In addition, a height of conductive material 210 on various portions of optical element 220 may depend on the technique used to deposit material 210 at S110.

[0052] Returning to process 100, dielectric material is deposited on the conductive material at S120. The dielectric material may comprise cured thick-film photoresist or any other suitable dielectric material. FIGS. 3A and 3B illustrate dielectric material 230 deposited on conductive material 210 according to some embodiments of S120.

[0053] Next, at S130, an aperture is created in the dielectric material using photolithography. Any photolithographic systems and techniques may be used to create the aperture. According to some embodiments, photoresist is deposited on the dielectric material, masked and patterned to define locations corresponding to the apertures. Photoresist disposed at those locations is removed and the exposed dielectric material is etched away to expose portions of the conductive material.

[0054] In a case that the dielectric material itself comprises photoresist, the dielectric material itself may be masked and patterned to define the aperture locations. The material at the locations is then removed to define the apertures. The dielectric material/photoresist may then require curing according to some embodiments. The use of photolithography at S130 may provide desired accuracy in the location of the apertures.

[0055] FIGS. 4A and 4B illustrate apparatus 200 after some embodiments of S130. Apertures 235 each expose a respective portion of conductive material 210. Dielectric material 230 may protect non-exposed portions of conductive material 210 while allowing soldering of electrical elements to the exposed portions of conductive material 210. Embodiments are not limited to the creation of four apertures as depicted in FIG. 4A.

[0056] An electrical contact of a solar cell is coupled to an exposed portion of the conductive material at S140. The coupling forms an electrical and a mechanical interconnection between the conductive material and the solar cell. Various flip-chip bonding techniques may be employed in some embodiments to couple the electrical contact of the solar cell to the exposed portion of the conductive material.

[0057] FIG. 5 is a close-up view of apparatus 200 after S140 according to some embodiments. Solder bumps 505 of solar cell 500 are coupled to conductive material 210 exposed by apertures 325. Solder bumps 505 are also respectively coupled to unshown terminals of solar cell 500.

[0058] Solar cell 500 may comprise a solar cell (e.g., a III-V cell, II-VI cell, etc.) for receiving photons from optical element 220 and generating electrical charge carriers in response thereto. In this regard, some embodiments include an opening through dielectric material 230 and conductive material 210 through which solar cell 500 may receive light from optical element 220. By accurately fabricating apertures 235, some

embodiments provide accurate placement of an optically-active area of solar cell 500 with respect to the opening. This accurate placement may allow for a smaller solar cell (i.e., less silicon) than would be required by designs providing less accurate placement.

[0059] FIG. 6 is a flow diagram of process 600 according to some embodiments. Process 600 may be performed by any combination of machine, hardware, software and manual means.

[0060] Process 600 begins at S605, at which an optical element is obtained. The optical element may be composed of any suitable material or combination of materials. The optical element may be created using any combination of devices and systems that is or becomes known.

[0061] FIG. 7A is a perspective view of optical element 700 created at S605 according to some embodiments, and FIG. 7B is a cross-sectional view of element 700. Optical element 700 may be molded from low-iron glass at S605 using known methods. Alternatively, separate pieces may be glued or otherwise coupled together to form element 700. Optical element 700 may comprise an element of a solar concentrator according to some embodiments.

[0062] Element 700 includes convex surface 710, pedestal 720, and concave surface 730. The purposes of each portion of element 700 during operation according to some embodiments will become evident from the description below.

[0063] A reflective material is deposited on the optical element at S610. The reflective material may be intended to create one or more mirrored surfaces. Any suitable reflective material may be used, taking into account factors such as but not limited to the wavelengths of light to be reflected, bonding of the reflective material to the optical element, and cost. The reflective material may be deposited by sputtering, evaporation, liquid deposition, etc.

[0064] FIGS. 8A and 8B show perspective and cross-sectional views, respectively, of optical element 700 after some embodiments of S610. Reflective material 740 is deposited on convex surface 710 and concave surface 730. Reflective material 740 may comprise sputtered silver or aluminum. The vertical and horizontal surfaces of pedestal 720 may be masked at S610 such that reflective material 740 is not deposited thereon, or otherwise treated to remove any reflective material 740 that is deposited thereon.

[0065] Next, at S615, an electrical insulator is deposited on the reflective material. The insulator may comprise any suitable insulator or insulators. Non-exhaustive examples include polymers, dielectrics, polyester, epoxy and polyurethane. The insulator may be deposited using any process that is or becomes known. In some embodiments, the insulator is powder-coated onto the optical element.

[0066] Some embodiments of S615 are depicted in FIGS. 9A and 9B. Insulator 750 is deposited on convex surface 710 or, more particularly, on reflective material 740. Again, S615 is executed such that insulator 750 is not deposited on the vertical and horizontal surfaces of pedestal 720. According to the illustrated embodiment, insulator 750 is not deposited on concave surface 730 (i.e., on reflective material 740 deposited on concave surface 730).

[0067] Returning to process 600, a pattern of conductive material is deposited on the insulator using a thick film process at S620. The conductive material may be composed of any combination of one or more materials (e.g., nickel, copper), and may be deposited using the thermal spraying, paste-

based, or other techniques described above. A stencil may be employed at S620 as also described.

[0068] FIG. 10A is a perspective view and FIG. 10B is a cross-sectional view of optical element 700 after S620 according to some embodiments. Conductive material 760 covers pedestal 720 and portions of insulator 750. Conductive material 770, which may be different from or identical to material 760, also covers portions of insulator 750. Conductive material 760 and conductive material 770 define a gap to facilitate electrical isolation from one another. Although conductive materials 760 and 770 appear to extend to a uniform height above element 700, this height need not be uniform.

[0069] Embodiments of S620 such as that depicted in FIGS. 10A and 10B may include placing a stencil in the shape of the illustrated gap on electrical isolator 750 and depositing conductive material 760 and 770 where shown and on the stencil. The stencil is then removed to result in the apparatus of FIGS. 10A and 10B.

[0070] Conductive materials 760 and 770 may create a conductive path for electrical current generated by a photovoltaic (solar) cell coupled to element 700. Conductive material 760 and conductive material 770 may also, as described in U.S. Patent Application Publication No. 2006/0231133, electrically link solar cells of adjacent solar concentrators in a solar concentrator array.

[0071] Aperture 765 may comprise an exit window for light entering element 700. Aperture 765 may be formed by masking a corresponding area of pedestal 720 prior to depositing conductive material 760. Such masking may comprise depositing a liquid or solid mask on pedestal 720 prior to S620 and removing (i.e., peeling or dissolving) the mask thereafter. Some embodiments employ photolithography to define aperture 765 after depositing conductive material on the entirety of pedestal 720 at S620.

[0072] At S625, dielectric material is deposited on the conductive material. Any suitable material of any suitable thickness may be deposited at S640 in any suitable manner. FIGS. 11A and 11B illustrate deposited dielectric material 780 according to some embodiments of S625. Portions of dielectric material 780 are shown sunken into aperture 765, but an upper surface of dielectric material 780 may be substantially flat in some embodiments.

[0073] Thin-film photoresist is deposited on the dielectric material at S630. The close-up perspective view of FIG. 12A illustrates photoresist 790 upon dielectric material 780. FIG. 11B is a cross-sectional view illustrating the several layers upon optical element 700 after S630.

[0074] The deposited photoresist is masked at S635 in accordance with a desired location of an aperture. Masking at S635 may proceed using known techniques and may depend on a desired accuracy, wavelength of exposing light, type of photoresist, etc. The masked photoresist is then exposed to light at S640 and, depending on whether the photoresist is "negative" or "positive", exposed or unexposed portions of the photoresist are removed at S645.

[0075] FIG. 13A shows photoresist 790 with several portions removed therefrom. Removal of the portions exposes portions 785 of dielectric material 180. Next, at S650, exposed portions 785 of the dielectric material are etched or otherwise removed to expose portions of the conductive material. FIGS. 14A and 14B show apertures 787 defined by dielectric material 780 after S650. Portions of conductive material 760 are exposed through apertures 787.

[0076] An electrical contact of a solar cell is coupled to an exposed portion of the conductive material at S6505. The electrical contact may be coupled such that an optically-active area of the solar cell is aligned with aperture 765. The electrical contact may comprise a solder bump, and any number of intermediate conductive elements such as various layers of bonding pads may be used to couple the electrical contact to the exposed portion.

[0077] FIG. 15 shows solder bumps 805 of solar cell 800 coupled to conductive material 760 exposed by apertures 787. Solar cell 800 includes window 810 for receiving light into an optically-active area of cell 800. Increasing the accuracy of alignment between window 810 and aperture 765 may allow for a reduction in the size of the optically-active area. Some embodiments provide improved accuracy by defining the exposed portions of the conductive material using thin film techniques and by coupling the solar cell to the exposed portions using flip-chip bonding. Some embodiments additionally provide reduced fabrication cost by fabricating the conductive material layer using thick film techniques.

[0078] Apparatus 700 of FIG. 15 may generally operate in accordance with the description of aforementioned U.S. Patent Application Publication No. 2006/0231133. With reference to FIG. 15, solar rays enter surface 798 and are reflected by reflective material 740 disposed on convex surface 710. The rays are reflected toward reflective material 740 on concave surface 730, and are thereafter reflected toward aperture 765. The reflected rays pass through aperture 765 and are received by window 810 of solar cell 800. Those skilled in the art of optics will recognize that combinations of one or more other surface shapes may be utilized to concentrate solar rays onto a solar cell.

[0079] Solar cell 800 receives a substantial portion of the photon energy received at surface 798 and generates electrical current in response to the received photon energy. The electrical current may be passed to external circuitry (and/or to similar serially-connected apparatuses) through conductive material 760 and conductive material 770. In this regard, solar cell 800 may also comprise an electrical contact electrically coupled to conductive material 770. Such a contact would exhibit a polarity opposite to the polarity of the contacts to which solder bumps 805 are coupled.

[0080] The several embodiments described herein are solely for the purpose of illustration. Embodiments may include any currently or hereafter-known versions of the elements described herein. Therefore, persons in the art will recognize from this description that other embodiments may be practiced with various modifications and alterations.

What is claimed is:

1. A method comprising:
 - depositing conductive material on an optical element using a thick film process;
 - depositing dielectric material on the conductive material;
 - creating an aperture in the dielectric material using photolithography to expose a portion of the conductive material; and
 - coupling an electrical contact of a solar cell to the exposed portion of the conductive material.
2. A method according to claim 1, wherein the dielectric material comprises thick photoresist, and wherein creating the aperture comprises:
 - masking the thick photoresist in accordance with a location of the aperture;
 - exposing the masked photoresist; and

- removing portions of the thick photoresist corresponding to the location of the aperture.
- 3. A method according to claim 1, wherein creating the aperture comprises:
 - depositing thin photoresist on the dielectric material;
 - masking the thin photoresist in accordance with a location of the aperture;
 - exposing the masked photoresist;
 - removing portions of the thin photoresist corresponding to the location of the aperture; and
 - etching away portions of the dielectric material corresponding to the location of the aperture.
- 4. A method according to claim 1, wherein creating the aperture comprises:
 - depositing thin photoresist on the conductive material;
 - masking the thin photoresist in accordance with a location of the aperture;
 - exposing the masked photoresist; and
 - removing portions of the thin photoresist corresponding to the location of the aperture,
 wherein depositing the dielectric material comprises depositing the dielectric material on the thin photoresist.
- 5. A method according to claim 1, wherein the conductive material deposited on the optical element defines a window from which light may pass out of the optical element, and wherein the electrical contact of the solar cell is coupled to the exposed portion of the conductive material such that an optically-active area of the solar cell is aligned with the window.
- 6. A method according to claim 1, wherein depositing the conductive material on the optical element comprises:
 - placing a stencil on the optical element; and
 - spraying molten conductive material on the stencil and the optical element.
- 7. A method according to claim 1, wherein depositing the conductive material on the optical element comprises:
 - placing a stencil on the optical element; and
 - depositing a paste of conductive material onto the stencil and the optical element.
- 8. A method according to claim 1, further comprising:
 - depositing a reflective material on the optical element; and
 - depositing an electrical isolator on the reflective material, wherein the conductive material is deposited on the electrical isolator.
- 9. A method according to claim 8, wherein the conductive material deposited on the optical element defines a window from which light may pass out of the optical element, and wherein the electrical contact of the solar cell is coupled to the exposed portion of the conductive material such that an optically-active area of the solar cell is aligned with the window.
- 10. An apparatus comprising:
 - an optical element comprising conductive material deposited on the optical element using a thick film process;
 - dielectric material disposed on the conductive material and defining an aperture created using photolithography, the aperture exposing a portion of the conductive material;
 - and

- a solar cell comprising an electrical contact coupled to the exposed portion of the conductive material.
- 11. An apparatus according to claim 10, wherein the dielectric material comprises thick photoresist, and wherein creating the aperture was created by masking the thick photoresist in accordance with a location of the aperture, exposing the masked photoresist, and removing portions of the thick photoresist corresponding to the location of the aperture.
- 12. An apparatus according to claim 10, wherein the aperture was created by depositing thin photoresist on the dielectric material, masking the thin photoresist in accordance with a location of the aperture, exposing the masked photoresist, removing portions of the thin photoresist corresponding to the location of the aperture, and etching away portions of the dielectric material corresponding to the location of the aperture.
- 13. An apparatus according to claim 10, wherein the aperture was created by depositing thin photoresist on the conductive material, masking the thin photoresist in accordance with a location of the aperture, exposing the masked photoresist, and removing portions of the thin photoresist corresponding to the location of the aperture, and
 - wherein depositing the dielectric material comprises depositing the dielectric material on the thin photoresist.
- 14. An apparatus according to claim 10, wherein the conductive material deposited on the optical element defines a window from which light may pass out of the optical element, and
 - wherein the electrical contact of the solar cell is coupled to the exposed portion of the conductive material such that an optically-active area of the solar cell is aligned with the window.
- 15. An apparatus according to claim 10, wherein the conductive material was deposited on the optical element by placing a stencil on the optical element, and spraying molten conductive material on the stencil and the optical element.
- 16. An apparatus according to claim 10, wherein the conductive material was deposited on the optical element by placing a stencil on the optical element, and rolling a paste of conductive material onto the stencil and the optical element.
- 17. An apparatus according to claim 10, further comprising:
 - a reflective material deposited on the optical element; and
 - an electrical isolator deposited on the reflective material, wherein the conductive material is deposited on the electrical isolator.
- 18. An apparatus according to claim 17, wherein the conductive material deposited on the optical element defines a window from which light may pass out of the optical element, and
 - wherein the electrical contact of the solar cell is coupled to the exposed portion of the conductive material such that an optically-active area of the solar cell is aligned with the window.

* * * * *