



INTERNATIONAL APPLICATION PUBLISHED UNDER THE PATENT COOPERATION TREATY (PCT)

<p>(51) International Patent Classification ⁶ : A61M 5/00</p>	<p>A1</p>	<p>(11) International Publication Number: WO 96/36377 (43) International Publication Date: 21 November 1996 (21.11.96)</p>
<p>(21) International Application Number: PCT/US96/06774 (22) International Filing Date: 13 May 1996 (13.05.96) (30) Priority Data: 113723 14 May 1995 (14.05.95) IL 08/623,238 27 March 1996 (27.03.96) US (71) Applicant (for all designated States except BB): OPTONOL LTD. [IL/IL]; Kiryat Atidim, P.O. Box 58165, 61581 Tel Aviv (IL). (71) Applicant (for BB only): WERNER, Mary, C. [US/US]; 0-155 Blue Hill Avenue, Fair Lawn, NJ 07410 (US). (72) Inventors: RICHTER, Jacob; Hanafa 8, 47414 Ramat Hasharon (IL). PINCHASIK, Gregory; 23 Golomb Street, 47414 Ramat Hasharon (IL). YARON, Ira; 93836 Har Adar 215 (IL). (74) Agents: BRAINARD, Charles, R. et al.; Kenyon & Kenyon, One Broadway, New York, NY 10004 (US).</p>		<p>(81) Designated States: AL, AM, AT, AU, AZ, BB, BG, BR, BY, CA, CH, CN, CZ, DE, DK, EE, ES, FI, GB, GE, HU, IS, JP, KE, KG, KP, KR, KZ, LK, LR, LS, LT, LU, LV, MD, MG, MK, MN, MW, MX, NO, NZ, PL, PT, RO, RU, SD, SE, SG, SI, SK, TJ, TM, TR, TT, UA, UG, UZ, VN, ARIPO patent (KE, LS, MW, SD, SZ, UG), Eurasian patent (AM, AZ, BY, KG, KZ, MD, RU, TJ, TM), European patent (AT, BE, CH, DE, DK, ES, FI, FR, GB, GR, IE, IT, LU, MC, NL, PT, SE), OAPI patent (BF, BJ, CF, CG, CI, CM, GA, GN, ML, MR, NE, SN, TD, TG).</p> <p>Published With international search report.</p>

(54) Title: INTRAOCULAR IMPLANT, DELIVERY DEVICE, AND METHOD OF IMPLANTATION

(57) Abstract

An ophthalmic implant for treatment of glaucoma includes a tube (32) and a flanged disk (34) connected to an outlet end (50) of the tube (32). The tube passage (38) is sized sufficiently small to inhibit the flow of aqueous humor through the tube passage (38) when the IOP is below a threshold amount. An inlet end of the tube has a beveled surface (40) and one or more circumferential holes (42). One or more outwardly extending retention projections (52) are provided for anchoring in the eyeball. The flanged disk has an outer rim and one or more inner uprights. The implant is implanted by use of a handle and a rodlike instrument (60), with a tip for insertion into the tube passage of the implant and a retention mechanism for retaining the implant.

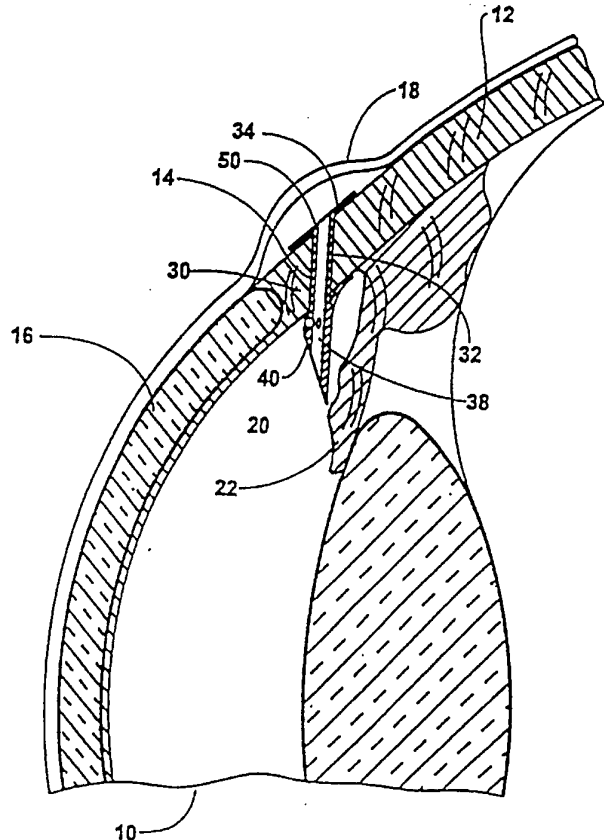

FOR THE PURPOSES OF INFORMATION ONLY

Codes used to identify States party to the PCT on the front pages of pamphlets publishing international applications under the PCT.

AM	Armenia	GB	United Kingdom	MW	Malawi
AT	Austria	GE	Georgia	MX	Mexico
AU	Australia	GN	Guinea	NE	Niger
BB	Barbados	GR	Greece	NL	Netherlands
BE	Belgium	HU	Hungary	NO	Norway
BF	Burkina Faso	IE	Ireland	NZ	New Zealand
BG	Bulgaria	IT	Italy	PL	Poland
BJ	Benin	JP	Japan	PT	Portugal
BR	Brazil	KE	Kenya	RO	Romania
BY	Belarus	KG	Kyrgystan	RU	Russian Federation
CA	Canada	KP	Democratic People's Republic of Korea	SD	Sudan
CF	Central African Republic	KR	Republic of Korea	SE	Sweden
CG	Congo	KZ	Kazakhstan	SG	Singapore
CH	Switzerland	LI	Liechtenstein	SI	Slovenia
CI	Côte d'Ivoire	LK	Sri Lanka	SK	Slovakia
CM	Cameroon	LR	Liberia	SN	Senegal
CN	China	LT	Lithuania	SZ	Swaziland
CS	Czechoslovakia	LU	Luxembourg	TD	Chad
CZ	Czech Republic	LV	Latvia	TG	Togo
DE	Germany	MC	Monaco	TJ	Tajikistan
DK	Denmark	MD	Republic of Moldova	TT	Trinidad and Tobago
EE	Estonia	MG	Madagascar	UA	Ukraine
ES	Spain	ML	Mali	UG	Uganda
FI	Finland	MN	Mongolia	US	United States of America
FR	France	MR	Mauritania	UZ	Uzbekistan
GA	Gabon			VN	Viet Nam

INTRAOCULAR IMPLANT, DELIVERY DEVICE,
AND METHOD OF IMPLANTATION

FIELD OF THE INVENTION

The invention relates generally to ophthalmic
5 implants for treatment of glaucoma, delivery devices for
implanting such implants, and to methods of implanting
such implants.

BACKGROUND OF THE INVENTION

Glaucoma is an eye condition characterized by
10 an increase in the intraocular pressure (IOP) of the eye
to an abnormal level. A normal eye maintains a proper
IOP by the circulation within the eye of aqueous humor --
aqueous humor is secreted from the ciliary body, passes
through the pupil into the anterior chamber of the
15 eyeball, and is filtered out of the eyeball via the
trabeculum and the Canal of Schlemm. With glaucoma, the
aqueous humor excretory pathway is blocked, the aqueous
humor cannot pass out of the eyeball at an adequate rate,
the IOP rises, the eyeball becomes harder, and the optic
20 nerve atrophies by the pressure applied on its fibers
leaving the retina. A characteristic optic neuropathy
develops, resulting in progressive death of the ganglion
cells in the retina, restriction of the visual field, and
eventual blindness. Advanced stages of the disease are
25 characterized also by significant pain.

Glaucoma treatment, if initiated early in the
course of the disease, can prevent further deterioration
and preserve most of the ocular functions. The goal of
glaucoma treatment is to reduce the IOP to a level which
30 is considered safe for a particular eye, but which is not
so low as to cause ocular malfunction or retinal
complications.

One type of glaucoma treatment is filtration
surgery, which provides an alternate route for aqueous
35 humor to exit the anterior chamber of the eyeball and
enter the sub-conjunctival space, thereby lowering the

IOP. In full thickness operations a fistula is created through the limbal sclera, connecting directly the anterior chamber of the eyeball and the sub-conjunctival space. Full thickness operations provide long-lasting control of IOP; however, excessive loss of aqueous humor from the eyeball during the early postoperative period frequently leads to hypotony.

In guarded filtration surgery (trabeculectomy), a fistula created through the limbal sclera is protected by an overlying partial thickness sutured scleral flap. The scleral flap provides additional resistance to excessive loss of aqueous humor from the eyeball, thereby reducing the risk of early postoperative hypotony. However, trabeculectomy may result in higher eventual IOP and increased risk of late failure of filtration, compared with full thickness operations.

In accordance with one recently introduced procedure, a full thickness filtering fistula may be created by a holmium laser probe, with minimal surgically induced trauma. After retrobulbar anesthesia, a conjunctival incision (approximately 1 mm) is made about 12-15 mm posterior to the intended sclerostomy site, and a laser probe is advanced through the sub-conjunctival space to the limbus. Then, multiple laser pulses are applied until a full thickness fistula is created. This technique has sometimes resulted in early hypotony on account of a difficulty in controlling the sclerostomy size. In addition, early and late iris prolapse into the sclerostomy has resulted in abrupt closure of the fistula and eventual surgical failure. Further, despite its relative simplicity, the technique still necessitates the use of retrobulbar anesthesia to avoid pain caused by the laser applications. The injection of anesthetic material close to the already damaged optic nerve may sometimes lead to further visual damage. A further disadvantage of this procedure, as well as other types of glaucoma filtration surgery, is the propensity of the fistula to

be sealed by scarring.

Various attempts have been made to overcome the problems of filtration surgery, for example, by using ophthalmic implant devices. Typical ophthalmic implants
5 utilize drainage tubes so as to maintain the integrity of the openings formed in the eyeball for the relief of the IOP.

Typical ophthalmic implants suffer from several disadvantages. For example, the implants typically
10 utilize a valve mechanism for regulating the flow of aqueous humor from the eyeball; defects in and/or failure of such valve mechanisms could lead to excessive loss of aqueous humor from the eyeball and possible hypotony. The implants also tend to clog over time, either from the
15 inside by tissue, such as the iris, being sucked into the inlet, or from the outside by the proliferation of cells, for example by scarring. Additionally, the typical implant insertion operation is complicated, costly and takes a long time.

20 United States Patent No. 3,788,327 to Donowitz et al. shows a prior art implant utilizing a valve mechanism for regulating the flow of aqueous humor from the eyeball. As stated above, defects in and/or failure of such a valve mechanism could lead to excessive loss of
25 aqueous humor from the eyeball and possible hypotony. Additionally, both the inlet opening and the outlet opening in the implant shown in United States Patent No. 3,788,327 may be susceptible to clogging -- the inlet opening by the iris and the outlet opening by scarring.
30 Finally, implantation of an implant according to United States Patent No. 3,788,327 may involve the separate steps of first providing a tract for receiving the implant and/or suturing the implant once it is in place, which add time and possible complications to the
35 operation.

SUMMARY OF THE INVENTION

It is an object of the invention to provide an improved ophthalmic implant which may be implanted into the eyeball for the treatment of glaucoma, a delivery
5 device for implanting such an implant, and an improved method of implanting such an implant into the eyeball.

In one embodiment of an improved implant in accordance with the invention, an intraocular implant is provided to be implanted in the eyeball. The implant
10 includes a tube having an inlet end, an outlet end, and a tube passage therebetween for permitting aqueous humor to flow out of the eyeball, and a flanged disk connected to the tube at the outlet end of the tube. The tube passage has a cross-sectional area sufficiently small to inhibit
15 the flow of aqueous humor through the tube passage when the IOP is below a threshold amount, thereby preventing the IOP from falling below its critical limit.

The flanged disk, which is designed to be located underneath the conjunctiva, may have an outer rim
20 for forming a reservoir having an enlarged cross-sectional area relative to the cross-sectional area of the tube passage. When the IOP is above the threshold amount such that aqueous humor is able to flow through the tube passage, the elasticity of the conjunctiva in
25 conjunction with this design of the flanged disk assists in regulating the flow of aqueous humor through the tube as a function of the IOP.

To prevent clogging of the implant, the tube at its inlet end may be provided with a beveled surface
30 which faces away from the iris when the implant is inserted. Additionally, one or more circumferential holes may be provided along the tube for allowing aqueous humor to flow into the tube passage even if the axial inlet opening is blocked.

35 To prevent clogging at the outlet end, the flanged disk may have an outer rim as described above which raises the conjunctiva away from the axial outlet

of the tube passage to allow outflow. One or more inner uprights (which may be in the form of an inner rim) may also be provided on the flanged disk for this purpose. Clogging is further avoided by implanting the implant
5 under the conjunctiva at a distance away from an insertion slit in the conjunctiva, such that healing of the slit does not cause scar tissue to form in the area of the axial outlet opening of the implant.

Implantation may be facilitated by further
10 features of the implant. For example, the implant may have one or more retention projections (for example, in the form of a spur, flange, or plate). The retention projection may be rigid, or it may be made of an elastic material such that it is able to be flexed inward against
15 the tube during penetration through the sclera. Alternatively, the retention projection may be designed to lie initially relatively flat against the tube for easier penetration through the sclera and to prevent tearing of the sclera, with a mechanism for extending the
20 retention projection outwardly when the implant is implanted in the eyeball. For example, the retention projection may be extended outwardly by a separate expansion tool or may be constructed of a shape memory alloy so that it is extended outwardly when subjected to
25 the heat of the eyeball. One or more retention projections according to the invention are sufficient to reliably anchor the implant in the eyeball without the need for sutures, saving time and costs.

Implantation may also be facilitated by the
30 provision of one or more markers on the implant visible through the cornea upon passing through the sclera. For example, a circumferential hole as described above may serve as a marker; alternatively, the marker may be some other suitable visible mechanism, such as a scratch or
35 colored mark on the tube. The visibility of the marker lets the doctor know that the marker has passed through the sclera, indicating that the implant is in place.

Implantation of an implant may be performed by use of a delivery device in accordance with the invention, comprising a handle and a rodlike instrument, for example a needle or probe, for carrying the implant
5 for insertion into the eyeball. The delivery device has a tip for insertion into the tube passage of the implant and a suitable retention mechanism for preventing the implant from moving up the delivery device during implantation. The retention mechanism may also be
10 constructed to prevent the implant from rotating during implantation to insure proper orientation of the implant in the eyeball. The delivery device may additionally have a suitable expansion tool for extending one or more retention projections of the implant outwardly once the
15 projection or projections have penetrated through the sclera.

In one embodiment of an improved method of implanting an implant according to the invention, a small slit is cut in a portion of the conjunctiva which
20 normally lies at a distance away from the intended implantation site. As the implant itself is very small, the slit also may be very small, for example about 2 mm in length or less. The small size of the slit as well as its positioning at a distance away from the implantation
25 site, for example about 10 mm, helps prevent contamination of the sclerostomy site and reduces the risk of infection.

The implant is placed through the slit, directed to the implantation site, and inserted into the
30 sclera at the implantation site. The sclera may be pierced either by a needle-like tip of the tube of the implant formed by a beveled surface at the inlet end of the tube as described above or by the tip of a needle of the delivery device which carries the implant. Thus, the
35 implant may be inserted directly into the eyeball without the need for any separate piercing step, resulting in cost and time savings.

An intraocular implant, delivery device, and method of implantation according to the invention provide the advantages of a full thickness fistula, while avoiding the limitations of the standard trabeculectomy.

5 An implant according to the invention may be very small and implantable without surgery. No surgery room or hospitalization is necessary, thereby reducing costs. Implantation is minimally invasive, simple and quick, requiring only local anesthesia. Retrobulbar anaesthesia

10 is not necessary, and thus iatrogenic damage to the optic nerve is avoided. There is no need to perform an iridectomy, and thus aqueous flow is maintained, lens nourishment is unaffected, and the likelihood of cataracts developing as a result of the procedure is

15 reduced.

BRIEF DESCRIPTION OF THE DRAWINGS

- Figure 1 is a schematic cross-sectional view of a first embodiment of an intraocular implant according to the invention, shown inserted in an eyeball;
- 20 Figure 2 is an enlarged perspective view of the intraocular implant of Figure 1;
- Figure 3 is a view similar to Figure 2, with part of the intraocular implant cut away to show a sectional view thereof;
- 25 Figure 4 is an enlarged perspective view of a disk portion of the intraocular implant of Figure 1;
- Figures 5 through 7 illustrate the action of the conjunctiva during operation of the intraocular implant of Figure 1;
- 30 Figures 8 through 10 illustrate a delivery device and insertion of the intraocular implant of Figure

1 into an eyeball;

5 Figure 11 is an enlarged perspective view of a second embodiment of an intraocular implant according to the invention, with part of the intraocular implant cut away to show a sectional view thereof;

Figure 12 is a top view of the intraocular implant of Figure 11, showing a flanged disk portion of the implant;

10 Figure 13 illustrates a delivery device and insertion of the intraocular implant of Figure 11 into an eyeball;

15 Figure 14 is a schematic cross-sectional view of the intraocular implant of Figure 11, shown inserted in an eyeball; and

Figures 15 and 16 illustrate a third embodiment of an intraocular implant according to the invention.

DETAILED DESCRIPTION OF THE DRAWINGS

20 Figure 1 illustrates an intraocular implant 30, constructed in accordance with an embodiment of the invention, implanted in an eyeball 10. The implant 30 comprises a needle-like tube 32 and a flanged disk 34. The plane of the flanged disk 34 forms an angle with the tube 32 that corresponds to the angle between the surface of the sclera 12 and the axis of insertion of the implant 25 30. The implant 30 is inserted in the sclera 12 of the eyeball 10, in the limbal area 14 adjacent to the cornea 16, and protrudes into the anterior chamber 20 adjacent the iris 22. The implant 30 is inserted so that the 30 flanged disk 34 is placed on a surface of the sclera 12 underneath the conjunctiva 18. The implant 30 may be

placed above or below the Tenon's capsule (not shown). It will be appreciated by persons of ordinary skill in the art that the exact location for inserting the implant 30 is not restricted to that shown, and may be any other
5 suitable position, such as behind the iris 22.

Figure 2 shows an enlarged perspective view of the implant 30 of Figure 1, and Figure 3 shows a similar view, with part of the implant 30 cut away. The tube 32, which may take the form of a modified standard
10 retrobulbar tip, has an inlet end 40, an outlet end 50, and a tube passage 38 extending therebetween, with the tube passage 38 having an axial inlet 41 and an axial outlet 51. The flanged disk 34 is connected to the tube
15 small; for example the tube 32 may have a length of about 2 mm and a width of about 0.5 mm, and the flanged disk 34 may have a diameter of about 1 mm and a thickness of less than 0.1 mm.

The tube passage 38 has a cross-sectional area
20 sufficiently small to inhibit the flow of aqueous humor through the tube passage when the IOP of the eye is below a threshold amount, thereby preventing the IOP from falling below its critical limit. In one embodiment, for example, the cylindrical tube passage 38 has a diameter
25 of 300 micrometers, such that an IOP of 5 mm Hg is needed for the aqueous humor to flow out. Thus, by using a specified internal cross-sectional area for the tube passage, excessive loss of aqueous humor from the eyeball is prevented.

30 When the IOP is above the threshold amount, aqueous humor drains from the anterior chamber 20 of the eyeball 10 through the axial inlet 41 and one or more circumferential holes 42, through the tube passage 38, and into the space under the conjunctiva 18. The
35 circumferential holes 42 may take any suitable form; for example, they may be in the form of circular openings whose combined cross-sectional area is equal to the

cross-sectional area of the tube passage 38. The circumferential holes 42 prevent the tube passage 38 from becoming clogged at its inlet end because, even if the iris 22 obstructs the axial inlet 41, aqueous humor can still pass through the circumferential holes 42. In the event the axial inlet 41 is obstructed, the circumferential holes 42 also serve to cause a back pressure in the tube passage 38 to unclog the axial inlet 41. The circumferential holes 42 serve the additional purpose of insuring a proper insertion depth of the implant 30, as the upper hole is visible during implantation after penetration through the sclera and thus can be used as a marker. To serve this function, any other suitable marker (such as a scratch or colored mark) may be used.

The inlet end 40 of the tube 32 has a needle-like tip formed by a beveled surface 36, angled sharply for easy insertion into the eyeball. The beveled surface 36 increases the area of the axial inlet 41 to enlarge the entrance to the tube passage 38. The beveled surface 36 is designed to face away from the iris 22 to reduce the possibility of obstruction of the axial inlet 41. Because the flanged disk 34 is designed to rest against the sclera 14 and the beveled surface 36 is designed to face away from the iris 22, the beveled surface 36 lies in a plane which is angled opposite to the plane in which the flanged disk 34 lies.

The tube 32 may have one or more retention projections in the form of one or more spurs 52 provided integrally with it for retaining the implant 30 in the eyeball 10 after insertion. Alternatively, the retention spur 52 may be made as a separate part connected to the tube 32 by, for example, welding or brazing. The retention spur 52 may be rigid, or it may be flexible such that it bends toward the tube 32 during penetration of the sclera and springs outward to its original shape after passing through the sclera. Alternatively, the

retention spur 52 may be designed for plastic deformation by a separate expansion tool (for example, a balloon) once it is in the eyeball 10, or the retention spur 52 may be constructed of a shape memory alloy such that the spur is flat against the tube when cool but expands to its final shape when subjected to the heat of the eyeball 10.

The flanged disk 34, shown enlarged in Figure 4, comprises a base 44, an outer rim 46, and a plurality of inner uprights 48. The base 44 and outer rim 46 define a reservoir 54 such that, in operation, the aqueous humor flows out of the axial outlet 51 of the tube passage 38, between the uprights 48, and into the reservoir 54. The enlarged cross-sectional area of the reservoir 54 as compared to the cross-sectional area of the tube passage 38 provides a larger area for absorption of the aqueous humor by the conjunctiva 18 and also acts in conjunction with the elasticity of the conjunctiva 18 to assist in regulating the flow of aqueous humor through the implant 30 as a function of the IOP.

Figures 5 through 7 illustrate the action of the conjunctiva 18 during operation of the implant 30, in which it can be seen that the aqueous humor which flows out of the tube passage forms a "bleb" 24 below the conjunctiva 18. It will be appreciated by persons having ordinary skill in the art that a higher IOP results in a higher flow rate through the implant 30, and a greater force of the aqueous humor on the conjunctiva 18.

In addition to defining the reservoir 54, the outer rim 46 of the flanged disk 34 serves the additional purpose of raising the conjunctiva 18 away from the axial outlet 51 to prevent clogging of the tube passage 38. The inner uprights 48 also serve this purpose.

The shape of the flanged disk 34 may be, but is not limited to, an ellipse, and it will be appreciated by persons having ordinary skill in the art that it may conform to any shape which allows the implant to fit

under the conjunctiva 18 and which regulates the IOP. The size and/or shape of the flanged disk 34 and/or the angle between the flanged disk 34 and the tube 32 can also be changed in order to use different implants for
5 different persons' eyes.

Figures 8 through 10 illustrate a delivery device 60 and a method of inserting the intraocular implant 30 into an eyeball. The implant 30 is first attached to the delivery device 60, having a handle 62
10 and a suitable rodlike instrument 64 such as a needle or probe. The rodlike instrument 64 has a tip 70 for penetrating a tube passage of the implant 30 and a retention mechanism for preventing the implant from moving up the delivery device during implantation, for
15 example in the form of an abutment surface 68 having an angle generally corresponding to that of the flanged disk 34. This configuration also prevents rotation of the implant 30 on the delivery device 60, thereby insuring proper orientation of the implant in the eyeball. The
20 retention mechanism may also include one or more projections for extending inside the outer rim and/or between the inner uprights on the flanged disk 34. In an alternative embodiment, the retention mechanism may be the tip of the rodlike instrument, constructed to engage
25 the inside of the tube passage of the implant with a friction fit, thereby preventing the implant from moving up the delivery device during implantation.

A delivery device 60 in which the rodlike instrument is a needle 65 is illustrated in Figure 9. In
30 that illustrated embodiment, the delivery device 60 is similar to a standard medical syringe having a housing and a needle 65 with a bore 67. The front tip 69 of the needle 65 is configured as an abutment surface having an angle generally corresponding to that of the flanged disk
35 34. The bore 67 of the needle 65 has a tip in the form of a plug 71 which is configured to have a cross-sectional shape corresponding to that of the tube passage

38. The implant 30 is placed over the plug 71, with the end of the plug 71 projecting into the tube passage 38, and with the front tip 69 of the needle 65 abutting against the flanged disk 34. The plug 71 blocks the tube passage 38 during implantation.

To insert the implant 30 into the eyeball 10, a small slit 26 is cut in a portion of the conjunctiva 18 which normally lies at a distance away from a portion 28 of the conjunctiva 18 which normally covers the intended implantation site. A small slit distanced away from the implantation site, for example a 1-2 mm slit about 5-15 mm away from the implantation site, reduces the possibility of aqueous humor flowing out of the conjunctiva through the slit, reduces the possibility of infection, reduces the possibility of scarring over the axial outlet of the implant, and facilitates closing and healing.

The implant 30, by delivery device 60, is passed through the slit 26, under the conjunctiva 18, to the implantation site in the sclera 14. Figure 9 shows the advancement of the implant only schematically; it will be appreciated that in practice the implant is directed from the slit to the implantation site generally along the surface of the sclera, such that the longitudinal axis of the implant is generally parallel to the surface of the sclera. Upon reaching the implantation site, the implant is tilted for penetration into the sclera. The acute angle of the needle-like tip formed by the beveled surface 36 of the implant 30 ensures that the implant 30 enters the sclera 14 easily. The needle-like tip penetrates through the sclera 14 into the anterior chamber 20 of the eyeball 10, while the flanged disk 34 is pushed up against the sclera 14.

When the implant 30 is in place, as shown in Figure 10, the retention spur (or spurs) 52 anchors the implant 30 in the eyeball 10 and prevents the implant 30 from sliding out as the delivery device 60 is withdrawn.

The retention spur 52 also prevents the implant 30 from slipping out once in place.

It will be appreciated by persons having ordinary skill in the art that the insertion of the
5 implant is not restricted to the method described above, and it may be inserted by any of several methods known in the art. The delivery device may comprise an 'internal' or 'external' needle. A straight or twisted guide wire,
10 known in the art, may also be used to guide the delivery device to its precise position. To ease insertion, the delivery device may be vibrated, or a lubricant, such as medical paste or gel, can be spread onto the delivery device. Additionally, after implantation of the implant
15 a suitable fibrosis inhibiting compound (e.g. 5FU, mitomycin) may be applied to the implantation site.

Figure 11 shows an alternative embodiment of an intraocular implant 130 constructed in accordance with the invention. The implant 130 comprises a tube 132
20 attached to an elliptical flanged disk 134. The tube 132 has an inlet end 140, an outlet end 150, and a tube passage 138, with the tube passage 138 having an axial inlet 141, an axial outlet 151, and circumferential holes 142 to drain the aqueous humor from the anterior chamber
25 20 of the eyeball 10 into the space under the conjunctiva 18.

The distal end 152 of the tube 132 has a partially conical shape. A plurality of retention projections in the form of retention flanges 158 are
30 formed on the outer circumference of the tube 132, approximately parallel to the flanged disk 134, to act as anchors to retain the implant 130 in the eyeball.

As shown in the enlarged view in Figure 12, the flanged disk 134 comprises an elliptical base 144, an outer rim 146, and an inner upright curved to form an
35 inner rim 148, defining therebetween a reservoir 154. A plurality of "U"-shaped passageways 156 are formed in the inner rim 148 for allowing aqueous humor to flow from the

axial outlet 151 into the reservoir 154. The outer rim 146 and the inner rim 148 prevent the conjunctiva 18 from clogging the axial outlet 151.

As shown in Figure 12, the flanged disk 134 is
5 elliptical in shape. The longer axis of the flanged disk 134 is approximately twice the diameter of the tube 132, and the flanged disk 134 is eccentrically displaced relative to the tube 132. The elliptical shape and
10 placement of the flanged disk 134 allows a wide anchoring area for the implant 130 and maximizes the outlet drainage area on the longer axis of the ellipse. The shorter axis of the ellipse enables the implant 130 to fit within the narrow space under the conjunctiva 18.

Figure 13 illustrates a delivery device 160 and
15 a method of inserting the intraocular implant 130 into an eyeball. The implant 130 is slidably fixed over a needle 164 of the delivery device 160, which, similar to a standard medical syringe, has needle 164 attached to a housing 162. The tip 174 of needle 164, which passes
20 through the implant 130, is acutely angled so that the tip 174 is generally in line with the angle of the lower part the implant 130.

A front surface of the delivery device 160 is formed as an abutment surface angled to match the angle
25 of the flanged disk 134 and further comprises an indent 172 to hold the implant 130 in place during implantation. The shape of the delivery device 160 and the angled surface of the flanged disk 134 prevent the implant 130 from rotating during implantation.

30 The delivery device 160 shown in Figure 13 is used in a manner similar to that described above with reference to Figures 8 through 10. In this embodiment, however, the acute angle of the needle tip 174 pierces the sclera. The angled inlet end of the implant device
35 130 follows the needle tip 174 through the sclera 14, into the anterior chamber 20 of the eyeball. As shown in Figure 14, the retention flanges 158 anchor the implant

130 in position and prevent the implant 130 from sliding out as the delivery device 160 is withdrawn. The anchorage of the retention flanges 158 also prevents the implant 130 from slipping out once in place.

5 Figures 15 and 16 illustrate a third embodiment of an intraocular implant according to the invention. This embodiment is similar to that shown in Figures 1 through 10, with the exception that a separately attached retention projection in the form of a retention plate 252
10 is used for anchoring instead of the retention spur 52. The retention plate is inserted into a groove 253 in the tube of the implant 230 and may be fastened by any suitable means, for example by welding in the case of an implant 230 constructed of stainless steel.

15 An intraocular implant constructed in accordance with the invention may be manufactured entirely from or covered with any suitable material such as stainless steel, silicon, gold, nitinol, Teflon, tantalum, PMMA, or any other suitable plastic or other
20 material. The implant may also be coated with heparin or any other suitable biology active compound.

 Manufacture of an intraocular implant in accordance with the invention may be carried out according to the following process. The tube may be
25 formed from the tip of a standard stainless steel hypodermic needle. Using an EDM machine, small holes are drilled proximate the tip of the needle to form the circumferential holes. At a distance from the tip corresponding to the desired length of the tube, the
30 needle is cut at the appropriate angle to correspond to the desired angle of the flanged disk. The side of the needle is then undercut to form a projection which can be later bent outwardly to form the spur.

 The disk may be chemically etched from a
35 stainless steel sheet according to the following process. A pattern of the disk is drawn on a computer aided design (CAD) system and plotted on a transparent film using a

laser plotter. Plottings are made of both the upper side and the lower side of the disk. The plotting for the upper side, for example, includes the outer rim and the inner uprights; the plotting for the lower side, for
5 example, includes the base of the disk.

A layer of photoresist is adhered to both surfaces of the stainless steel sheet. The photoresist is then exposed to UV light through the film on which the plottings are made. The areas of the sheet which are
10 blocked by the plottings are not exposed. The photoresist which has been exposed to UV light is then chemically removed.

Using an etching chemical, the stainless steel sheet is then etched, so that the chemical eats away the
15 areas of the sheet from which the photoresist has been removed. The etching is time-controlled such that the chemical only takes away material to a predetermined depth.

By use of a plotting for the upper side which
20 includes the outer rim and the uprights, the chemical on the upper surface of the sheet takes away material on the outside of the disk, in the reservoir including between the uprights, and in the center of the disk which is to receive the tube. Because the etching is time-
25 controlled, the chemical acting on the top of the sheet takes away material only part way through the thickness of the sheet. By use of a plotting for the lower side which includes the base of the disk, the chemical on the lower surface of the sheet takes away material on the
30 outside of the disk and in the center of the disk which is to receive the tube. The chemical acting on the bottom of the sheet takes away material part way through the thickness of the sheet. Because of action from both the top and the bottom, the material on the outside of
35 the disk and in the center of the disk which is to receive the tube is completely taken away by the etching process through the entire thickness of the sheet. A

small projection may be left on the outside of the disk during the etching process to prevent the disk from being dislodged from the sheet.

It will be appreciated by persons having
5 ordinary skill in the art that variations on this manufacturing process and other manufacturing processes are possible. For example, an implant made of plastic may be manufactured by a suitable molding operation.

As will also be appreciated by persons having
10 ordinary skill in the art, the various embodiments of intraocular implants, delivery devices, and methods for implantation described hereinabove are given by way of example only. Various changes, modifications and variations may be applied to the described embodiments
15 without departing from the scope of the invention, defined by the appended claims.

CLAIMS

WHAT IS CLAIMED IS:

1. An intraocular implant for implantation in an eyeball comprising:
 - a tube for implanting into the eyeball comprising an inlet end, an outlet end, and a tube passage extending between the inlet end and the outlet end for permitting aqueous humor to flow out of the eyeball; and
 - a flanged disk connected to the tube at the outlet end of the tube for placing on a surface of the eyeball;
 - wherein the tube passage has a cross-sectional area sufficiently small to inhibit the flow of aqueous humor through the tube passage when an intraocular pressure of the eyeball is below a threshold amount.
2. An intraocular implant according to claim 1 wherein the tube passage is cylindrical, and wherein a diameter of the tube passage is substantially smaller than a length of the tube passage.
3. An intraocular implant according to claim 2 wherein the diameter of the tube passage is about 300 micrometers or less.
4. An intraocular implant for implantation in an eyeball comprising:
 - a tube for implanting into the eyeball comprising an inlet end with a beveled surface at the inlet end, an outlet end, and a tube passage extending between the inlet end and the outlet end for permitting aqueous humor to flow out of the eyeball; and
 - a flanged disk connected to the tube at the outlet end of the tube for placing on a surface of

the eyeball;

wherein the beveled surface at the inlet end of the tube lies in a first plane forming an angle with the longitudinal axis of the tube and the flanged disk lies in a second plane which is angled opposite to the first plane.

5. An intraocular implant for implantation in an eyeball comprising:

a tube for implanting into the eyeball comprising an inlet end, an outlet end, and a tube passage extending between the inlet end and the outlet end for permitting aqueous humor to flow out of the eyeball; and

a flanged disk connected to the tube at the outlet end of the tube for placing on a surface of the eyeball;

wherein the tube has at least one circumferential hole which opens into the tube passage proximate the inlet end of the tube.

6. An intraocular implant for implantation in an eyeball comprising:

a tube for implanting into the eyeball comprising an inlet end, an outlet end, and a tube passage extending between the inlet end and the outlet end for permitting aqueous humor to flow out of the eyeball; and

a flanged disk connected to the tube at the outlet end of the tube for placing on a surface of the eyeball;

wherein the flanged disk comprises a base, an outer rim, and at least one inner upright, and wherein the base and outer rim form a reservoir having a larger cross-sectional area than the tube passage.

7. An intraocular implant according to claim 6 wherein at least one inner upright is curved to form an inner rim proximate an axial outlet opening of the tube and substantially bounding the axial outlet opening of the tube, the flanged disk further comprising at least one passageway in the inner rim for enabling flow of aqueous humor from the axial outlet opening through the passageway.
8. An intraocular implant according to claim 6 wherein the flanged disk has an elliptical shape.
9. An intraocular implant for implantation in an eyeball comprising:
 - a tube for implanting into the eyeball comprising an inlet end, an outlet end, and a tube passage extending between the inlet end and the outlet end for permitting aqueous humor to flow out of the eyeball; and
 - a flanged disk connected to the tube at the outlet end of the tube for placing on a surface of the eyeball;wherein the implant has at least one retention projection for anchoring the implant in the eyeball, said retention projection being extended outwardly when the implant is implanted in the eyeball.
10. An intraocular implant according to claim 9 wherein at least one retention projection is extended outwardly by an expansion tool when the implant is implanted in the eyeball.
11. An intraocular implant according to claim 9 wherein at least one retention projection is constructed of a shape memory alloy and is extended outwardly when subjected to the heat of the eyeball when the implant is implanted in the eyeball.

12. A method of regulating an intraocular pressure of an eyeball comprising the steps of:

providing an intraocular implant comprising (a) a tube for implanting into the eyeball, said tube comprising an inlet end, an outlet end, and a tube passage extending between the inlet end and the outlet end for permitting aqueous humor to flow out of the eyeball, said tube passage having a cross-sectional area sufficiently small to inhibit the flow of aqueous humor through the tube passage when an intraocular pressure of the eyeball is below a threshold amount, and (b) a flanged disk connected to the tube at the outlet end of the tube for placing on a surface of the eyeball; and

implanting the intraocular implant in the eyeball including implanting the tube into the eyeball and placing the flanged disk on a surface of the eyeball.

13. A delivery device for implanting an intraocular implant into an eyeball, the delivery device comprising:

a handle; and

a rodlike instrument;

wherein the rodlike instrument comprises a tip for penetrating a tube passage of the implant and a retention mechanism for retaining the implant on the delivery device.

14. A delivery device according to claim 13 wherein the rodlike instrument comprises a probe.
15. A delivery device according to claim 13 wherein the rodlike instrument comprises a needle.
16. A delivery device according to claim 15 wherein the tip of the rodlike instrument for penetrating a tube

passage of the implant comprises a plug inserted in a bore of the needle.

17. A delivery device according to claim 13 wherein the retention mechanism comprises an abutment surface for abutting a flanged disk of the implant, wherein the abutment surface has an angle generally corresponding to an angle of the flanged disk.
18. A method of implanting an intraocular implant into an eyeball comprising the steps of:
 - attaching the implant to a delivery device;
 - cutting a slit in a portion of the conjunctiva of the eyeball which normally lies at a distance away from an intended implantation site;
 - placing the implant by the delivery device through the slit in the conjunctiva;
 - directing the implant by the delivery device to the implantation site;
 - inserting the implant through the sclera at the implantation site;
 - withdrawing the delivery device; and
 - allowing the slit in the conjunctiva to be lie at the distance away from the implantation site.
19. A method of implanting an intraocular implant according to claim 18 wherein the distance between the slit in the conjunctiva and the implantation site is about 5 millimeters or more.
20. A method of implanting an intraocular implant according to claim 18 wherein the slit has a length of about 2 millimeters or less.
21. A method of implanting an intraocular implant according to claim 18 wherein, in the step of inserting the implant through the sclera, the sclera

- is penetrated by a tip of the tube of the implant.
22. A method of implanting an intraocular implant according to claim 18 wherein, in the step of inserting the implant through the sclera, the sclera is penetrated by a needle tip of the delivery device.
23. A method of implanting an intraocular implant into an eyeball comprising the steps of:
attaching the implant to a delivery device;
directing the implant by the delivery device to the implantation site;
inserting the implant through the sclera at the implantation site such that a beveled surface at an inlet end of the implant faces away from the iris;
and
withdrawing the delivery device.
24. A method of implanting an intraocular implant into an eyeball comprising the steps of:
attaching the implant to a delivery device;
directing the implant by the delivery device to the implantation site;
inserting the implant through the sclera at the implantation site such that a marker is visible upon penetration through the sclera; and
withdrawing the delivery device.
25. A method of implanting an intraocular implant according to claim 24 wherein the marker comprises a circumferential hole.
26. A method of implanting an intraocular implant into an eyeball comprising the steps of:
attaching the implant to a delivery device;
directing the implant by the delivery device to

the implantation site;
inserting the implant through the sclera at the
implantation site;
extending outwardly at least one retention
projection for anchoring the implant in the eyeball;
and
withdrawing the delivery device.

27. A method of implanting an intraocular implant according to claim 26 wherein, in the step of extending outwardly at least one retention projection, at least one retention projection is extended outwardly by an expansion tool when the implant is implanted in the eyeball.
28. A method of implanting an intraocular implant according to claim 26 wherein, in the step of extending outwardly at least one retention projection, at least one retention projection is extended outwardly by the action of a shape memory alloy from which it is constructed when subjected to the heat of the eyeball when the implant is implanted in the eyeball.
29. A method of implanting an intraocular implant into an eyeball comprising the steps of:
attaching the implant to a delivery device comprising a handle and a rodlike instrument comprising a tip for penetrating a tube passage of the implant and a retention mechanism for retaining the implant on the delivery device;
directing the implant by the delivery device to the implantation site;
inserting the implant through the sclera at the implantation site; and
withdrawing the delivery device.

30. A method of implanting an intraocular implant according to claim 29 wherein the retention mechanism comprises an abutment surface for abutting a flanged disk of the implant, wherein the abutment surface has an angle generally corresponding to an angle of the flanged disk.
31. A method of implanting an intraocular implant according to claim 29 further comprising the step of vibrating the delivery device during the step of inserting the implant through the sclera at the implantation site.

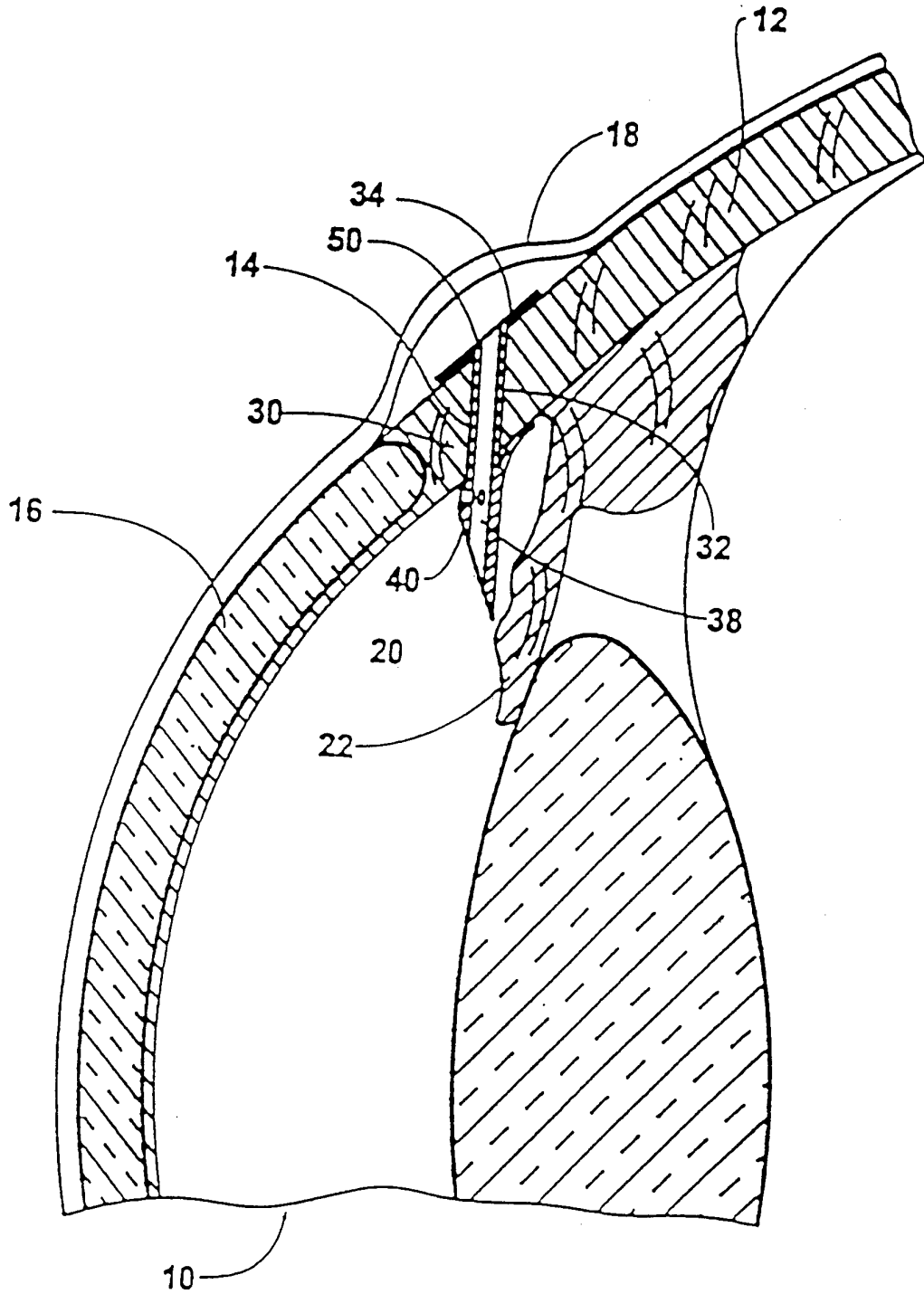
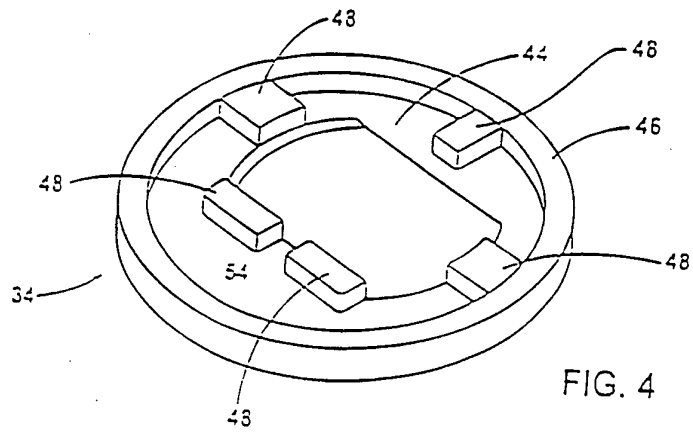
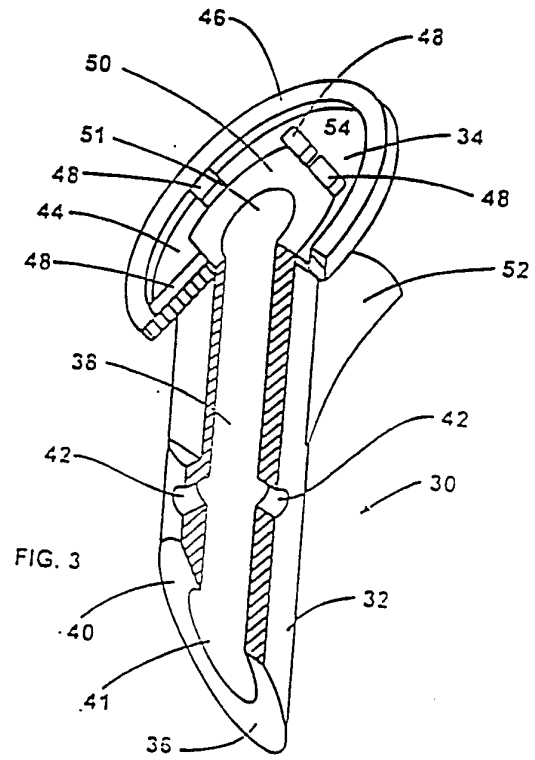
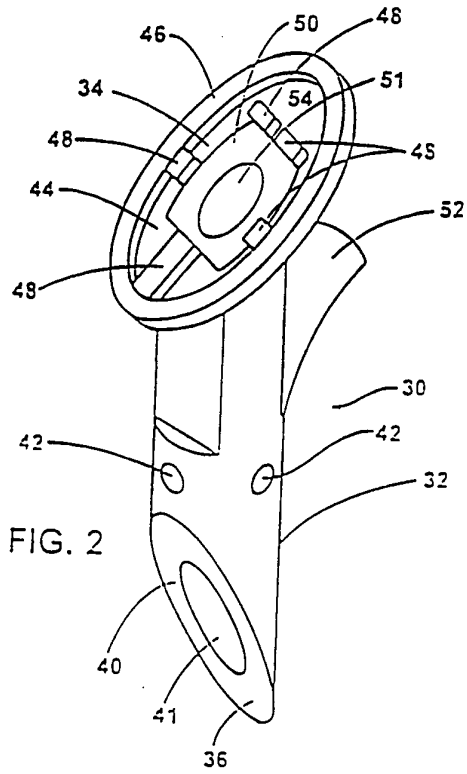

FIG. 1

SUBSTITUTE SHEET (RULE 26)



3/10

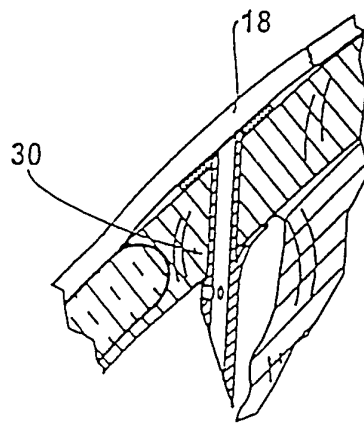

FIG. 5

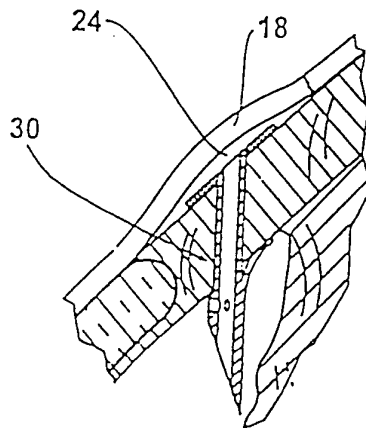

FIG. 6

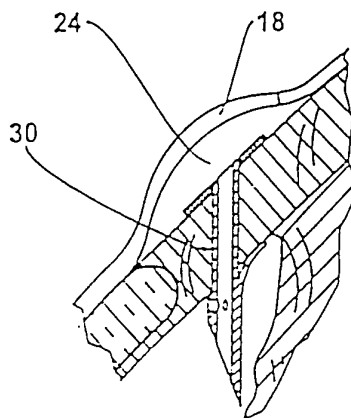

FIG. 7

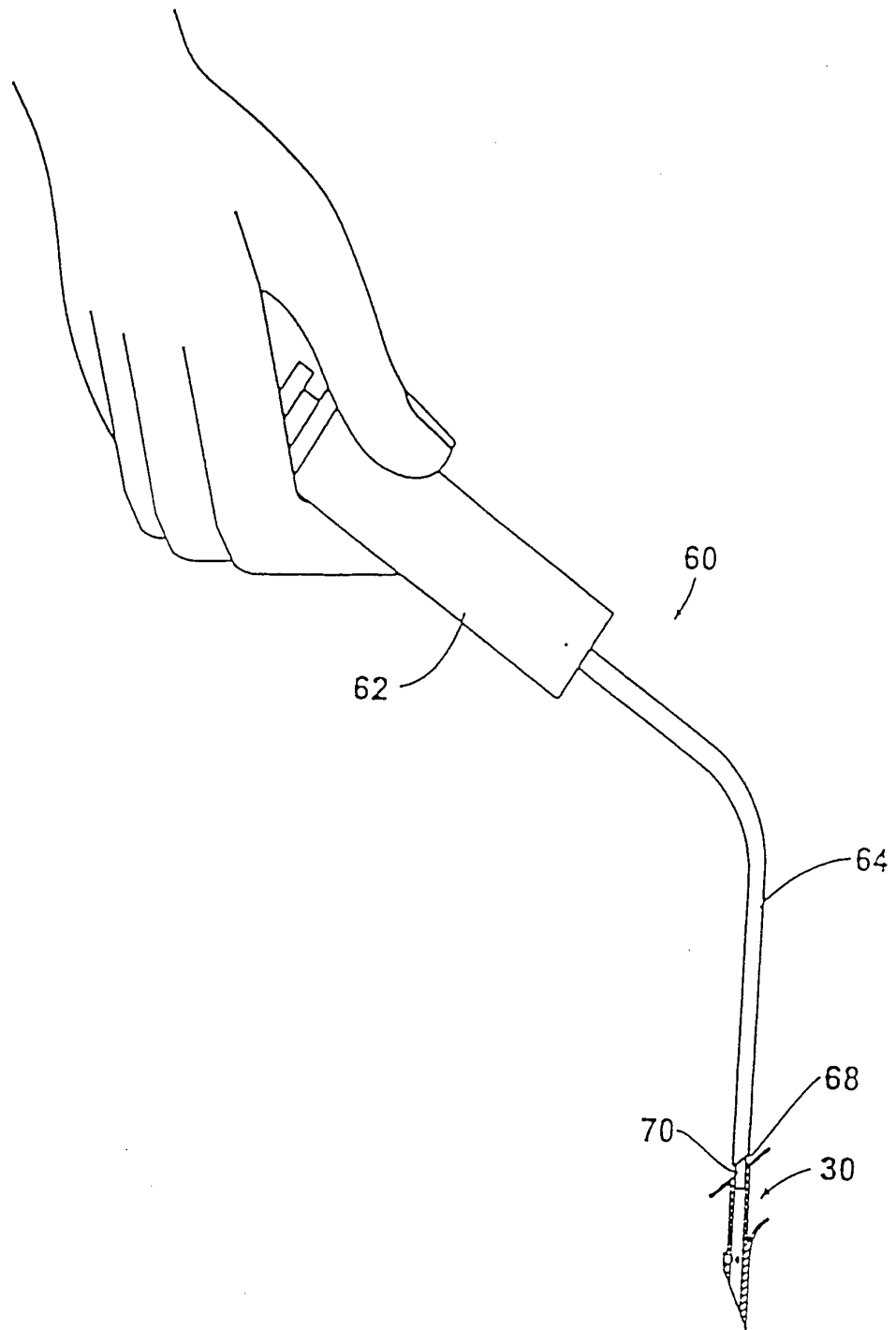

FIG. 8

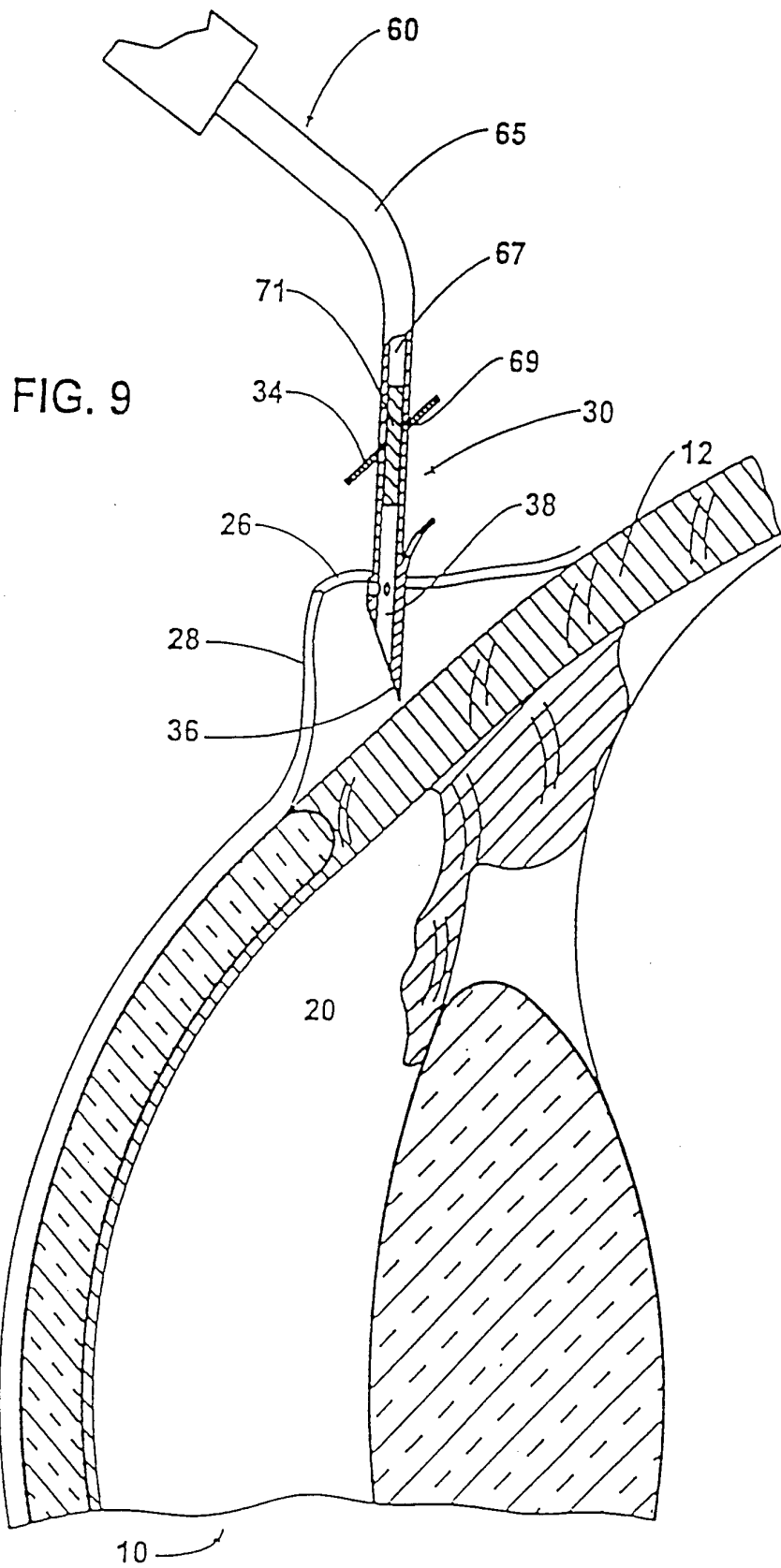

FIG. 9

SUBSTITUTE SHEET (RULE 26)

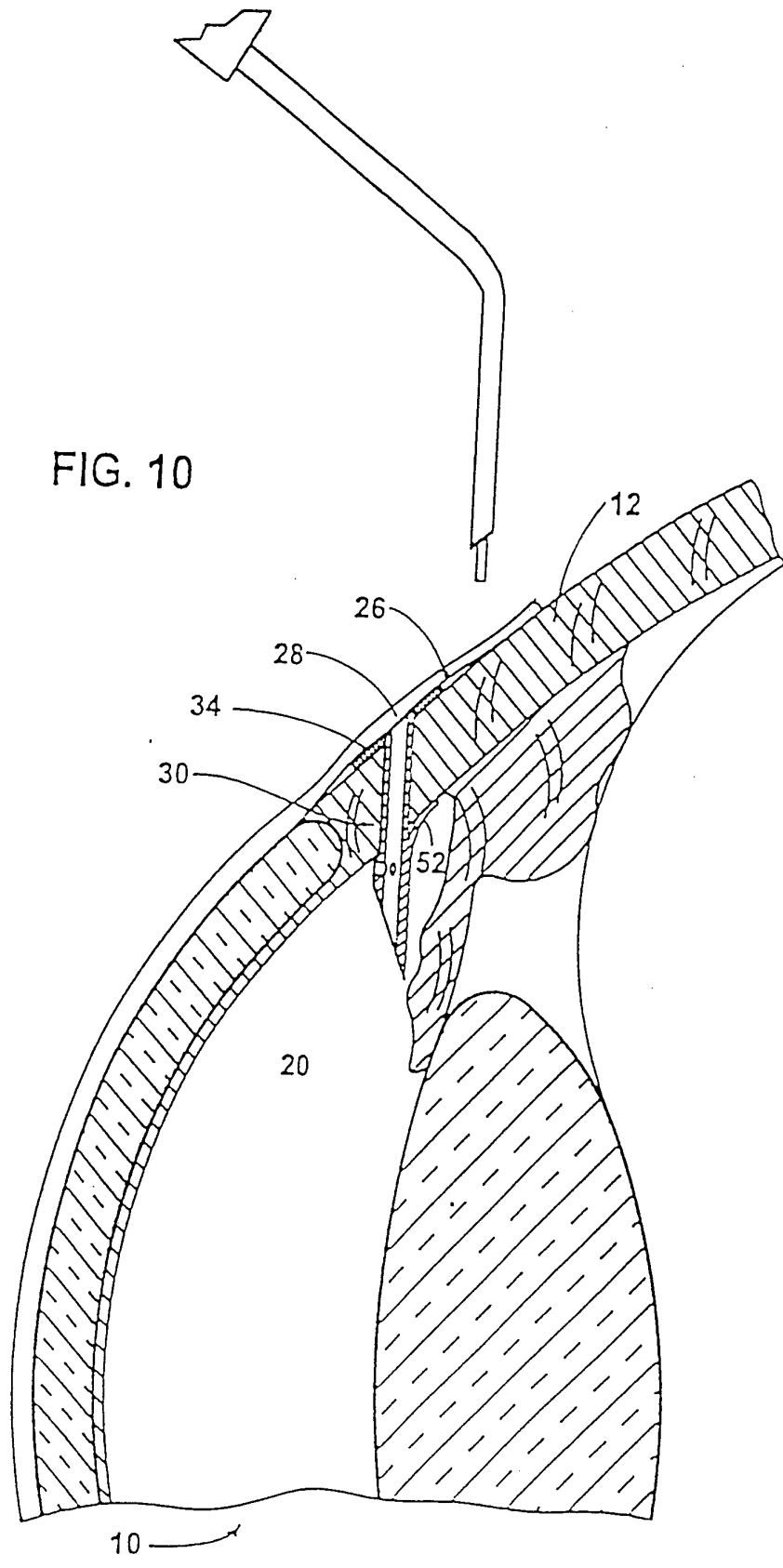

FIG. 10

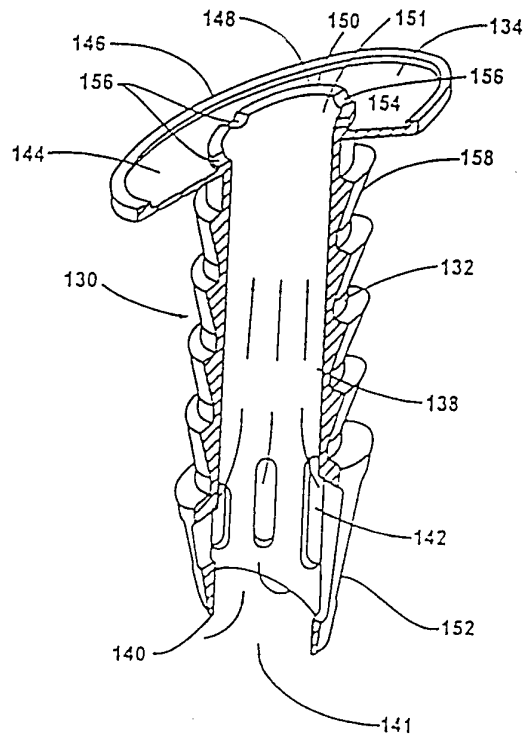

FIG. 11

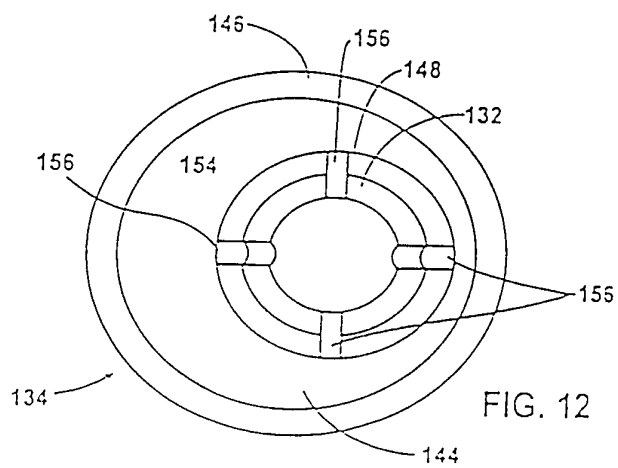
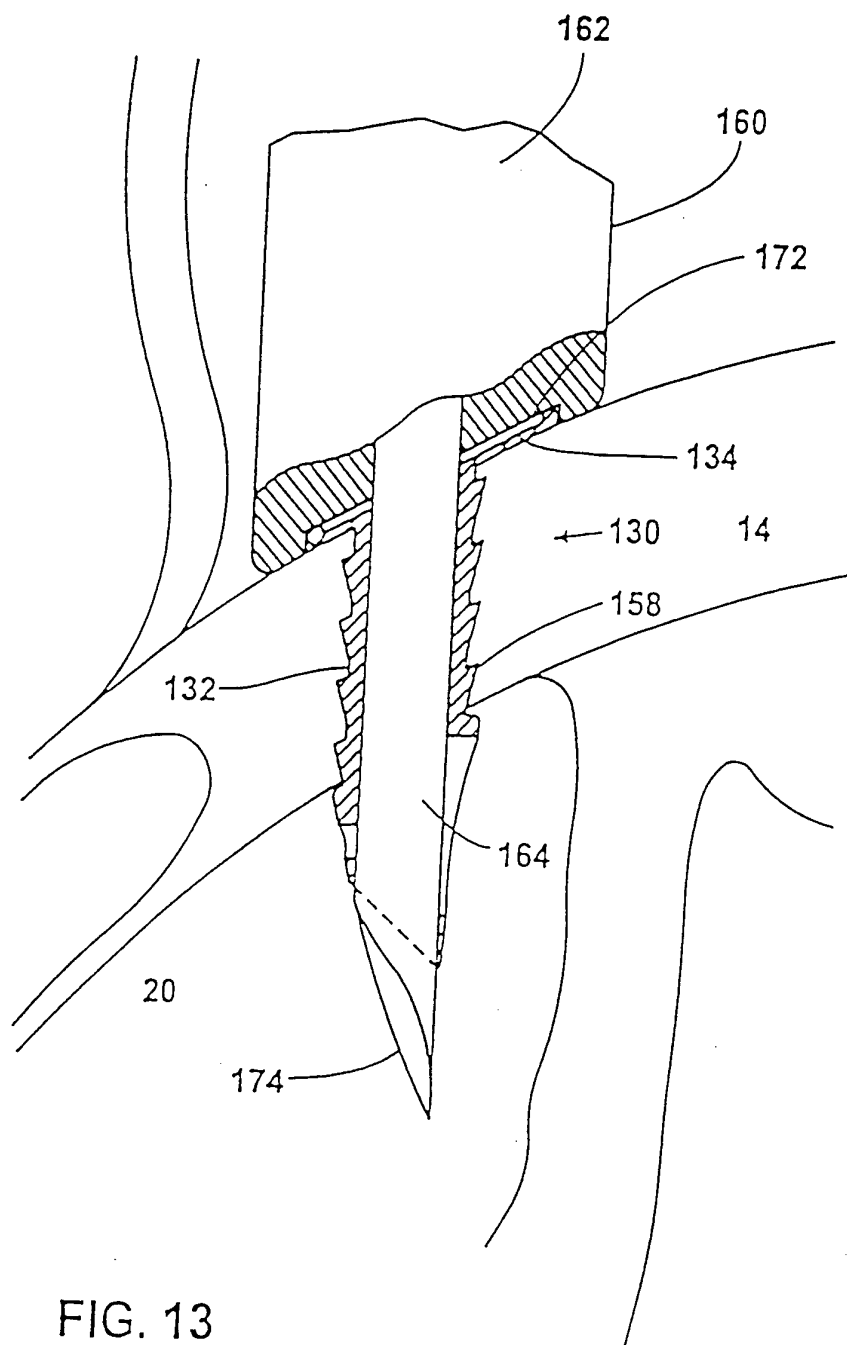

FIG. 12



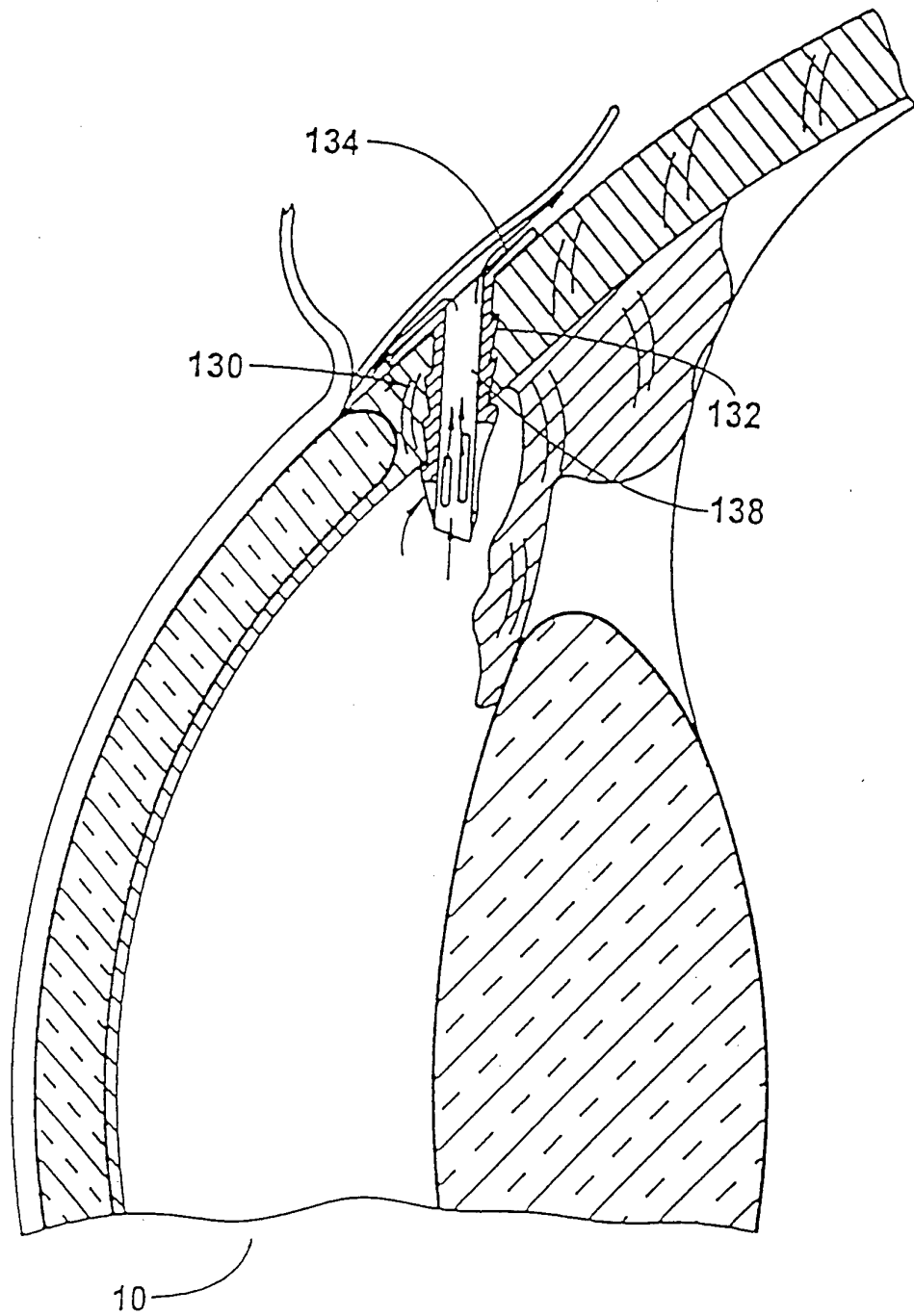
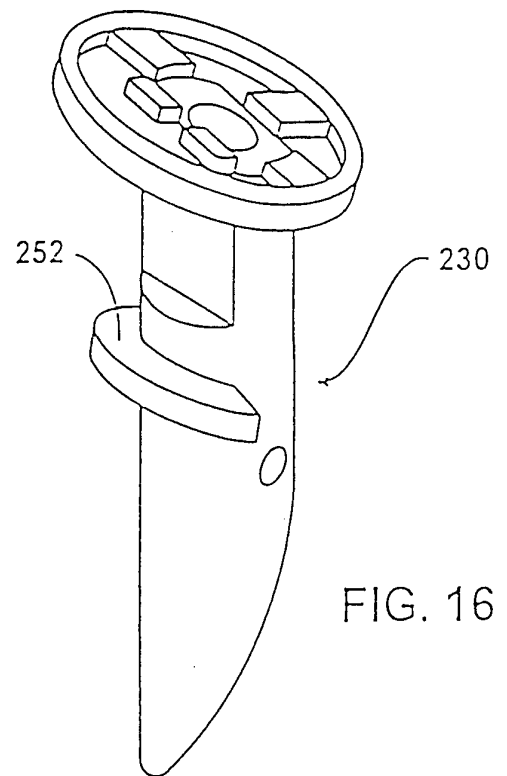
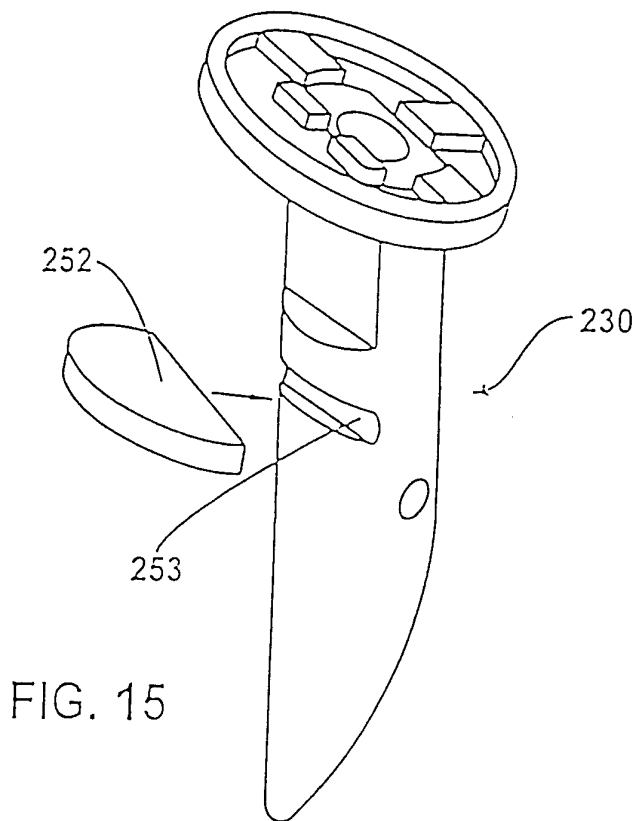

FIG. 14



INTERNATIONAL SEARCH REPORT

International application No.
PCT/US96/06774

A. CLASSIFICATION OF SUBJECT MATTER

IPC(6) :A61M 5/00
US CL :604/8

According to International Patent Classification (IPC) or to both national classification and IPC

B. FIELDS SEARCHED

Minimum documentation searched (classification system followed by classification symbols)

U.S. : 604/8-10, 294; 623/4; 606/107

Documentation searched other than minimum documentation to the extent that such documents are included in the fields searched

Electronic data base consulted during the international search (name of data base and, where practicable, search terms used)

C. DOCUMENTS CONSIDERED TO BE RELEVANT

Category*	Citation of document, with indication, where appropriate, of the relevant passages	Relevant to claim No.
X ---- Y	US, A, 4,402,681 (HAAS ET AL.) 06 September 1983, see entire document.	1, 2, 4 ----- 3, 6, 8, 9
X ---- Y	US, A, 5,190,552 (KELMAN) 02 March 1993, see all figures.	18, 19, 21, 22 ----- 20
X ---- Y	US, A, 5,494,484 (FEINGOLD) 27 February 1996, see Figure 28 as well as the entire disclosure.	23, 24, 26, 27 ----- 25

Further documents are listed in the continuation of Box C. See patent family annex.

* Special categories of cited documents:	"T" later document published after the international filing date or priority date and not in conflict with the application but cited to understand the principle or theory underlying the invention
"A" document defining the general state of the art which is not considered to be part of particular relevance	"X" document of particular relevance; the claimed invention cannot be considered novel or cannot be considered to involve an inventive step when the document is taken alone
"E" earlier document published on or after the international filing date	"Y" document of particular relevance; the claimed invention cannot be considered to involve an inventive step when the document is combined with one or more other such documents, such combination being obvious to a person skilled in the art
"L" document which may throw doubts on priority claim(s) or which is cited to establish the publication date of another citation or other special reason (as specified)	"&" document member of the same patent family
"O" document referring to an oral disclosure, use, exhibition or other means	
"P" document published prior to the international filing date but later than the priority date claimed	

Date of the actual completion of the international search 02 AUGUST 1996	Date of mailing of the international search report 26 AUG 1996
---	---

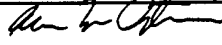
Name and mailing address of the ISA/US Commissioner of Patents and Trademarks Box PCT Washington, D.C. 20231 Facsimile No. (703) 305-3230	Authorized officer  MARY BETH JONES Telephone No. (703) 308-0858
---	---

INTERNATIONAL SEARCH REPORT

International application No.
PCT/US96/06774

C (Continuation). DOCUMENTS CONSIDERED TO BE RELEVANT		
Category*	Citation of document, with indication, where appropriate, of the relevant passages	Relevant to claim No.
A	US, A, 5,000,731 (WONG ET AL.) 19 March 1991, see Figures 1-3.	5
Y	US, A, 5,370,607 (MEMMEN) 06 December 1994, see Figure 5.	6
Y	US, A, 5,476,445 (BAERVELDT ET AL.) 19 December 1995, see Figure 6A.	6
Y	US, A, 5,300,020 (L'ESPERANCE, JR.) 05 April 1994, see entire document.	1-31
A	US, A, 4,968,296 (RITCH ET AL.) 06 November 1990, see entire document.	1-31