

(19) World Intellectual Property Organization
International Bureau



(43) International Publication Date
13 March 2008 (13.03.2008)

PCT

(10) International Publication Number
WO 2008/028490 A1

- (51) International Patent Classification:
H01Q 1/12 (2006.01) *H01Q 1/10* (2006.01)
F16B 7/14 (2006.01)
- (21) International Application Number:
PCT/DK2007/000401
- (22) International Filing Date:
7 September 2007 (07.09.2007)
- (25) Filing Language: Danish
- (26) Publication Language: English
- (30) Priority Data:
PA200601150 7 September 2006 (07.09.2006) DK
- (71) Applicant (for all designated States except US): **FALCK SCHMIDT DEFENCE SYSTEMS A/S** [DK/DK]; Oslo-gade 1, DK-5000 Odense C (DK).
- (72) Inventor; and
- (75) Inventor/Applicant (for US only): **FALCK-SCHMIDT, Jan** [DK/DK]; Lahngade 92, DK-5000 Odense C (DK).
- (74) Agent: **PATRADE A/S**; Fredens Torv 3A, 8000 Aarhus C (DK).

- (81) Designated States (unless otherwise indicated, for every kind of national protection available): AE, AG, AL, AM, AT, AU, AZ, BA, BB, BG, BH, BR, BW, BY, BZ, CA, CH, CN, CO, CR, CU, CZ, DE, DK, DM, DO, DZ, EC, EE, EG, ES, FI, GB, GD, GE, GH, GM, GT, HN, HR, HU, ID, IL, IN, IS, JP, KE, KG, KM, KN, KP, KR, KZ, LA, LC, LK, LR, LS, LT, LU, LY, MA, MD, ME, MG, MK, MN, MW, MX, MY, MZ, NA, NG, NI, NO, NZ, OM, PG, PH, PL, PT, RO, RS, RU, SC, SD, SE, SG, SK, SL, SM, SV, SY, TJ, TM, TN, TR, TT, TZ, UA, UG, US, UZ, VC, VN, ZA, ZM, ZW.
- (84) Designated States (unless otherwise indicated, for every kind of regional protection available): ARIPO (BW, GH, GM, KE, LS, MW, MZ, NA, SD, SL, SZ, TZ, UG, ZM, ZW), Eurasian (AM, AZ, BY, KG, KZ, MD, RU, TJ, TM), European (AT, BE, BG, CH, CY, CZ, DE, DK, EE, ES, FI, FR, GB, GR, HU, IE, IS, IT, LT, LU, LV, MC, MT, NL, PL, PT, RO, SE, SI, SK, TR), OAPI (BF, BJ, CF, CG, CI, CM, GA, GN, GQ, GW, ML, MR, NE, SN, TD, TG).

[Continued on next page]

(54) Title: TELESCOPIC MAST HAVING REDUCED PLAY

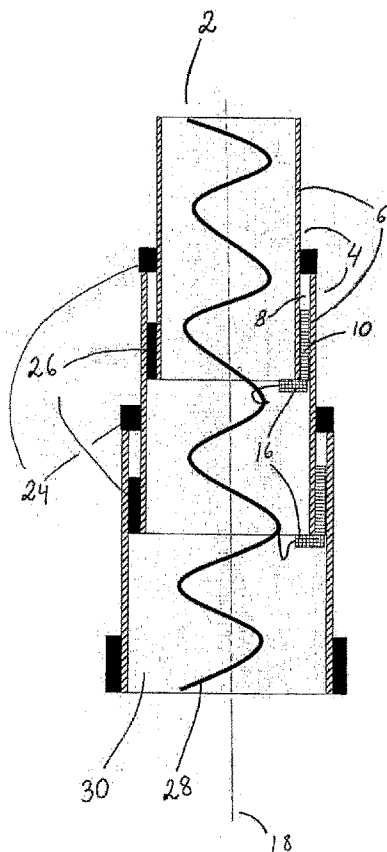

(57) Abstract: There is disclosed a telescopic mast (2) including two or more cylindrical telescoping sections (4) with parallel walls (6), where the distal one of two adjacent telescoping sections (4) is narrower than the proximal one of the two adjacent telescoping sections (4), so that the distal telescoping section (4) can be moved into and out of the proximal telescoping section (4), respectively. In the interspace (8) between two adjacent telescoping section (4) there is provided at least one means (10) interacting with an actuator (16) and pressing the adjacent walls (6) away from each other. Hereby play is eliminated or minimised.

WO 2008/028490 A1



Published:

- *with international search report*
- *before the expiration of the time limit for amending the claims and to be republished in the event of receipt of amendments*

Telescopic Mast having Reduced Play

Field of the Invention

The present invention concerns a telescopic mast including two or more cylindric telescoping sections with parallel walls, where the distal one of two adjacent telescoping sections is narrower than the proximal one of the two adjacent telescoping sections, so that the distal telescoping section can be moved into and out of the proximal telescoping section, respectively.

Background of the Invention

There are many kinds of telescopic masts of which some can be extended automatically. In connection with telescoping masts, e.g. for military use, there are special requirements to stability and accuracy. US 4,151,534 describes a free-standing mast for an antenna including a number of telescoping tubes. US 4,137,535 describes a telescopic mast which is controlled pneumatically. The mast includes a number of telescoping tubes that may be collapsed in a base section. A piston is integrated in each section. WO 0189981 describes a telescoping member with a nut which is rotatably fastened to a frame, a rotary pipe with thread engaging the nut. None of these inventions are adequately fulfilling the requirements to stability and accuracy.

Telescopic masts can be very high and may be used for sensors and weapons as well as for pointing out targets. High telescopic masts contain many telescoping sections. As play occurs between all adjacent telescoping sections of the mast, the play will accumulate in connection with high masts. Therefore, not the least in connection with high telescopic masts, it will very appropriate to minimise the play occurring between adjacent telescoping sections.

Object of the Invention

The object of the present invention is to provide a telescopic mast where the play between the telescoping sections is minimised. It is a further object of the invention to provide a telescopic mast that may be positioned with great accuracy.

Description of the Invention

According to the present invention, this is achieved with a telescopic mast including two or more cylindric telescoping sections with parallel walls, where the distal one of two adjacent telescoping sections is narrower than the proximal one of the two adjacent telescoping sections, so that the distal telescoping section can be moved into and out of the proximal telescoping section, respectively, where the telescopic mast is peculiar in that in the interspace between two adjacent telescoping sections there is provided at least one means that interacts with an actuator and presses the adjacent walls away from each other.

10

By a telescopic mast according to the invention is thus achieved a number of advantages, as the means pressing the adjacent walls away from each other minimises the play occurring between adjacent telescoping sections. By pressing the adjacent walls away from each other, the play is eliminated or minimised.

15

Means of different nature with regard to design as well as material may be used. It may be advantageous to make the means of materials that are dimensionally stable in connection with large temperature fluctuations. It may furthermore be advantageous to coat the means with a layer of friction reducing material, as e.g. Teflon, for minimising friction between and wear of the elements involved.

20

According to one embodiment, the telescopic mast according to the invention is peculiar in that the means is a rotary means interacting with an actuator which during use rotates the rotary means about an axis which is largely perpendicular to the longitudinal axis of the telescoping sections. Such an embodiment is advantageous as it enables using a rotary means which is elongated and has large contact surface, thereby enabling the provision of a continuous action on the walls in direction away from each other. It may be advantageous to use a rotary means which is slightly asymmetrical and/or in which the axis of rotation is displaced in relation to the central part of the means. Hereby is provided the possibility of positional variation of the areas on the means which are in contact with the walls. The rotary means may advantageously be covered by a friction reducing material, e.g. Teflon, in order to minimise friction and wear.

25

30

According to a second embodiment, the telescopic mast according to the invention is peculiar in that the means is a rotary member interacting with an actuator which during use rotates the rotary member about an axis which is largely parallel with the longitudinal axis of the telescoping sections. This embodiment also enables using a long rotary means having a large contact surface. A continuous action on the walls in direction away from each other may hereby be effected. It may be advantageous to use a rotary means which is slightly asymmetrical and/or in which the axis of rotation is displaced with regard to the central part of the means, as the possibility of varying the location of the areas on the means which are in contact with the walls is hereby provided. The rotary member may advantageously be covered by a friction reducing material, e.g. Teflon, in order to minimise friction between and wear of the members which are in mutual physical contact.

According to a third embodiment, the telescopic mast according to the invention is peculiar in that the means is a displacing means interacting with an actuator which during use displaces the displacing means in forward direction for pressing the walls away from each other. This embodiment enables using a play reducing member which does not have to be rotated. The displacing means may be designed as a cone or have other shapes. However, it is suitable to use a displacing means which is gradually tapered in forward direction, so that displacement in forward direction will gradually press the walls away from each other more and more. The displacing means may advantageously be covered by a friction reducing material, e.g. Teflon, in order to minimise friction between and wear of the members which are in mutual physical contact.

According to yet an embodiment, the telescopic mast according to the invention is peculiar in that there is used at least three rotary means and/or rotary members and/or displacing means. It will be suitable to distribute them with approximately the same mutual spacing so that adjacent telescoping sections are secured in a concentric position. Three rotary means and/or rotary members and/or displacing means are the lowest number that can ensure the securing of the adjacent telescoping sections in concentric position.

According to a further embodiment, the telescopic mast according to the invention is peculiar in that a pipe is provided within the telescoping sections. Such an embodiment will enable the carrying of power cables, liquid, gas or other matter through the pipes. Power cables will often be required to power central parts, such as actuators, or other equipment disposed along the telescoping sections or at the top of the mast.

It is possible to provide a telescopic mast in which a combination of a plurality of different means for pressing the walls away from each other is used .

10

The used actuators may e.g. be electric or pneumatic.

Description of the Drawing

The invention will in the following be explained more closely with reference to the accompanying drawing, wherein:

15

Fig. 1 shows a cross-sectional view (in longitudinal direction of the mast) of a first embodiment of a mast according to the invention, as seen from the front;

Fig. 2 shows a cross-sectional view (perpendicular to longitudinal direction of the mast) of a second embodiment of a mast according to the invention;

20

Fig. 3 shows a cross-sectional view (perpendicular to longitudinal direction of the mast) of a third embodiment of a mast according to the invention in perspective view; and

Fig. 4 shows a cross-sectional view (in longitudinal direction of the mast) of a fourth embodiment of a mast according to the invention, as seen from the front.

25

Detailed Description of the Invention

In the following description, identical or corresponding elements in the various embodiments will be provided with the same designations below.

30

Fig. 1 shows a first embodiment of a mast 2 according to the invention. The mast 2 includes three cylindric telescoping sections 4 with walls 6. An outer guide 26 is provided at the outer sides of the walls, near the proximal end of each telescoping

section 4. Also, an inner 24 is provided at the inner side of the walls 6 near the distal end of the walls. A means 10 interacting with an actuator 16 is provided in the interspace 8 between two adjacent telescoping sections 6. The actuator 16 is connected to a pipe 28 running through the inner cavity 3 of the telescoping sections. Electric power cables (not shown) run inside the pipe 28. The longitudinal axis 18 of the telescoping sections is indicated. During use, the means 10 presses the walls 6 away from each other, whereby the play is eliminated or minimised. Advantageously, there may be used three or more means 10 for pressing the walls 6 away from each other at several points. Adjacent telescoping sections are hereby secured in a concentric position. The guides 24, 26 ensure that adjacent telescoping sections are kept apart with a spacing allowing them to be moved into and out of each other.

Fig. 2 shows a second embodiment of a mast 2 according to the invention. On the Figure appears two circular cylindric telescoping sections with walls 6, where in the space between the telescoping sections there are provided three rotary means 12 which can rotate about an axis 14 which is standing perpendicularly to the longitudinal axis (not shown) of the telescoping sections. During use, the rotary means 12 presses the walls 6 away from each other, whereby the play is eliminated or minimised. An actuator (not shown) is used for providing the rotational movement of the rotary means.

Fig. 3 shows a third embodiment of a mast 2 according to the invention. On the Figure appears two circular, cylindric telescoping sections with walls 6, where in the space between the telescoping sections there are provided three rotary members 22 which can rotate about an axis 20 situated in parallel with the longitudinal axis of the telescoping sections. During use, the rotary members press the walls 6 away from each other, whereby the play is eliminated or minimised. An actuator (not shown) is used for providing the rotational movement of the rotary means.

Fig. 4 shows a fourth embodiment of a mast 2 according to the invention. On the Figure appears two circular, cylindric telescoping sections 4 with walls 6, where in the space between the telescoping sections 8 there is provided a displacing means 32 which is connected to an actuator 34. The direction forward F and the direction back T

are parallel with the longitudinal axis 18 of the telescoping sections. By means of the actuator 34, the displacing means 32 may be displaced in forward direction F and in backward direction T. By moving the displacing means 32 forward, the walls 6 are pressed away from each other. Hereby play is eliminated or minimised.

CLAIMS

1. A telescopic mast (2) including two or more cylindric telescoping sections (4) with parallel walls (6), where the distal one of two adjacent telescoping sections (4) is narrower than the proximal one of the two adjacent telescoping sections (4), so that the distal telescoping section (4) can be moved into and out of the proximal telescoping section (4), respectively, **characterised in that** that in the interspace (8) between two adjacent telescoping sections (4) there is provided at least one means (10) interacting with an actuator (16) and pressing the adjacent walls (6) away from each other.
2. Telescopic mast according to claim 1, **characterised in that** the means (10) is a rotary means (12) interacting with an actuator (16) which during use rotates the rotary means (10) about an axis (14) which is largely perpendicular to the longitudinal axis (18) of the telescoping sections.
3. Telescopic mast according to claim 1, **characterised in that** the means (10) is a rotary member (22) interacting with an actuator (16) which during use rotates the rotary member (22) about an axis (20) which is largely parallel with the longitudinal axis (18) of the telescoping sections.
4. Telescopic mast according to claim 1, **characterised in that** the means (10) is a displacing means (32) interacting with an actuator (34) which during use displaces the displacing means (32) in forward direction (F) for pressing the walls (6) away from each other.
5. Telescopic mast according to claim 4, **characterised in that** the displacing means (32) is covered by a friction reducing material, e.g. Teflon, in order to minimise friction between and wear of the means in contact.
6. Telescopic mast according to any of claims 1 - 5, **characterised in that** at least three of the above mentioned means (12, 22, 32) are applied.

7. Telescopic mast according to any of claims 1 - 6, **characterised in that** a pipe (28) is provided inside the telescoping sections (30).

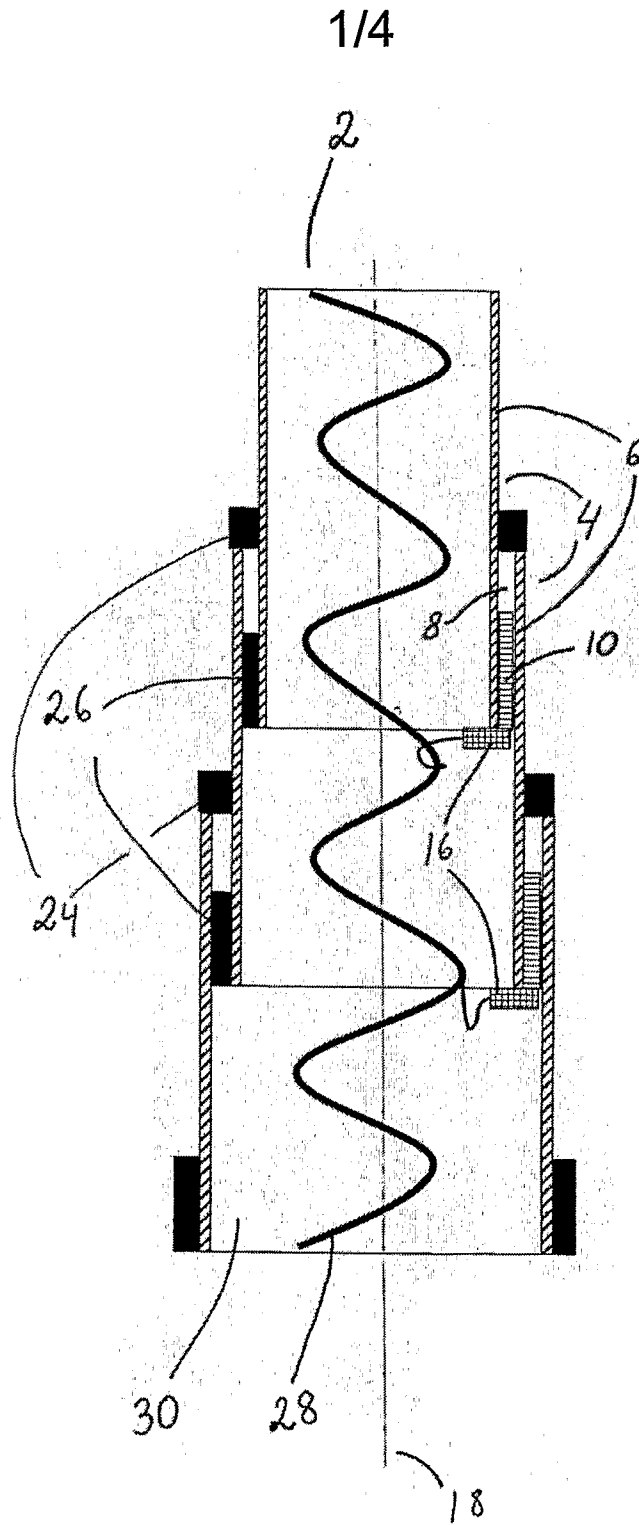

FIG. 1

2/4

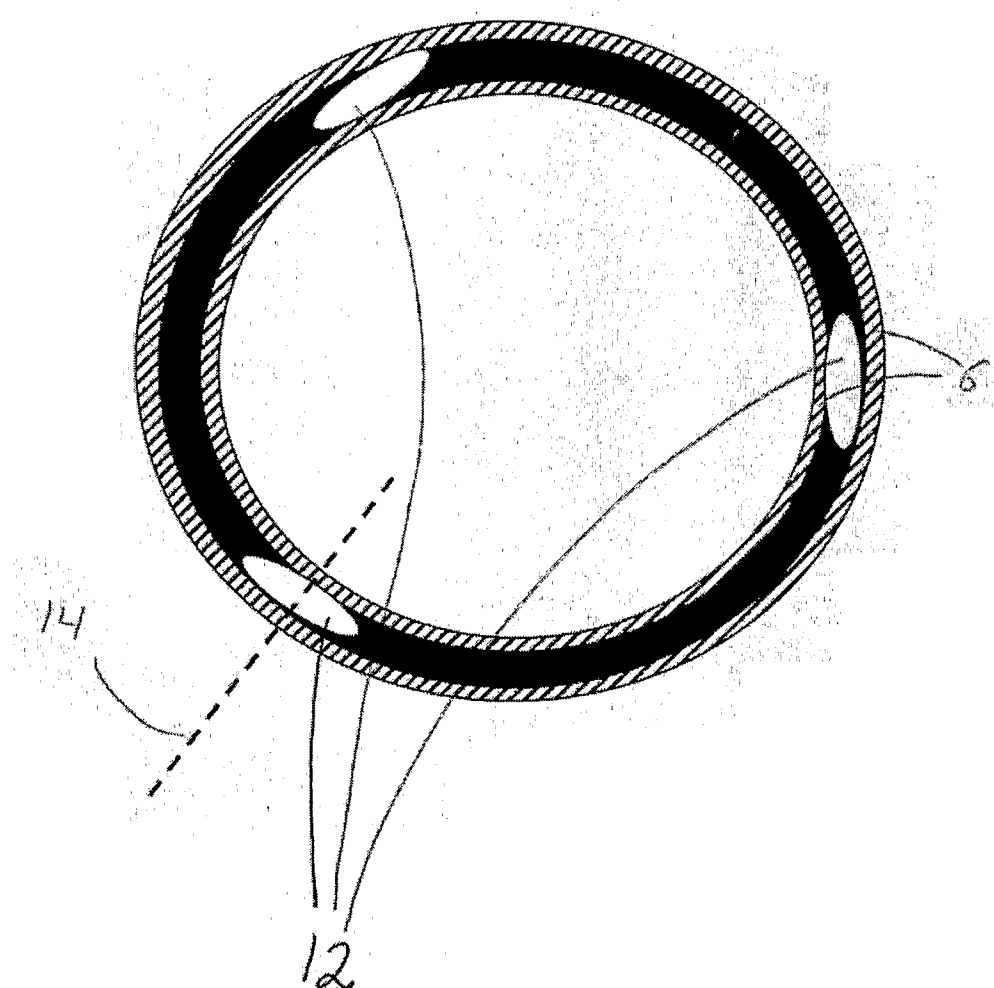

FIG. 2

3/4

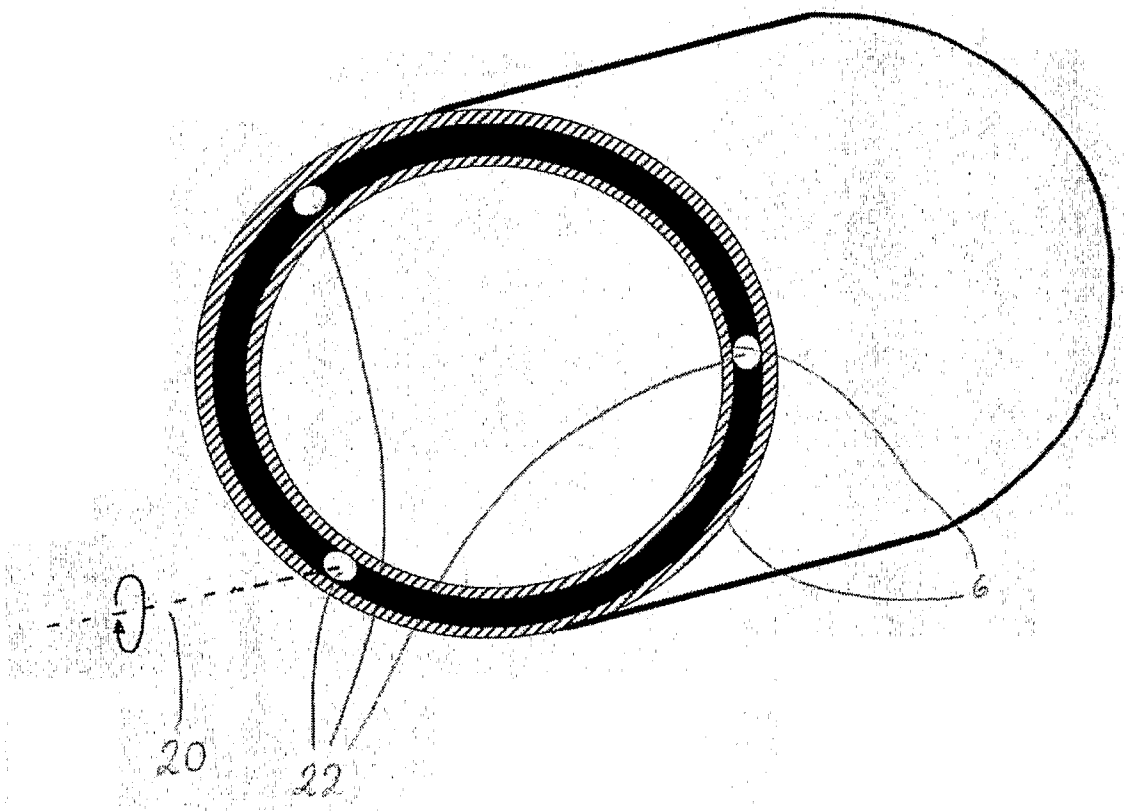

FIG. 3

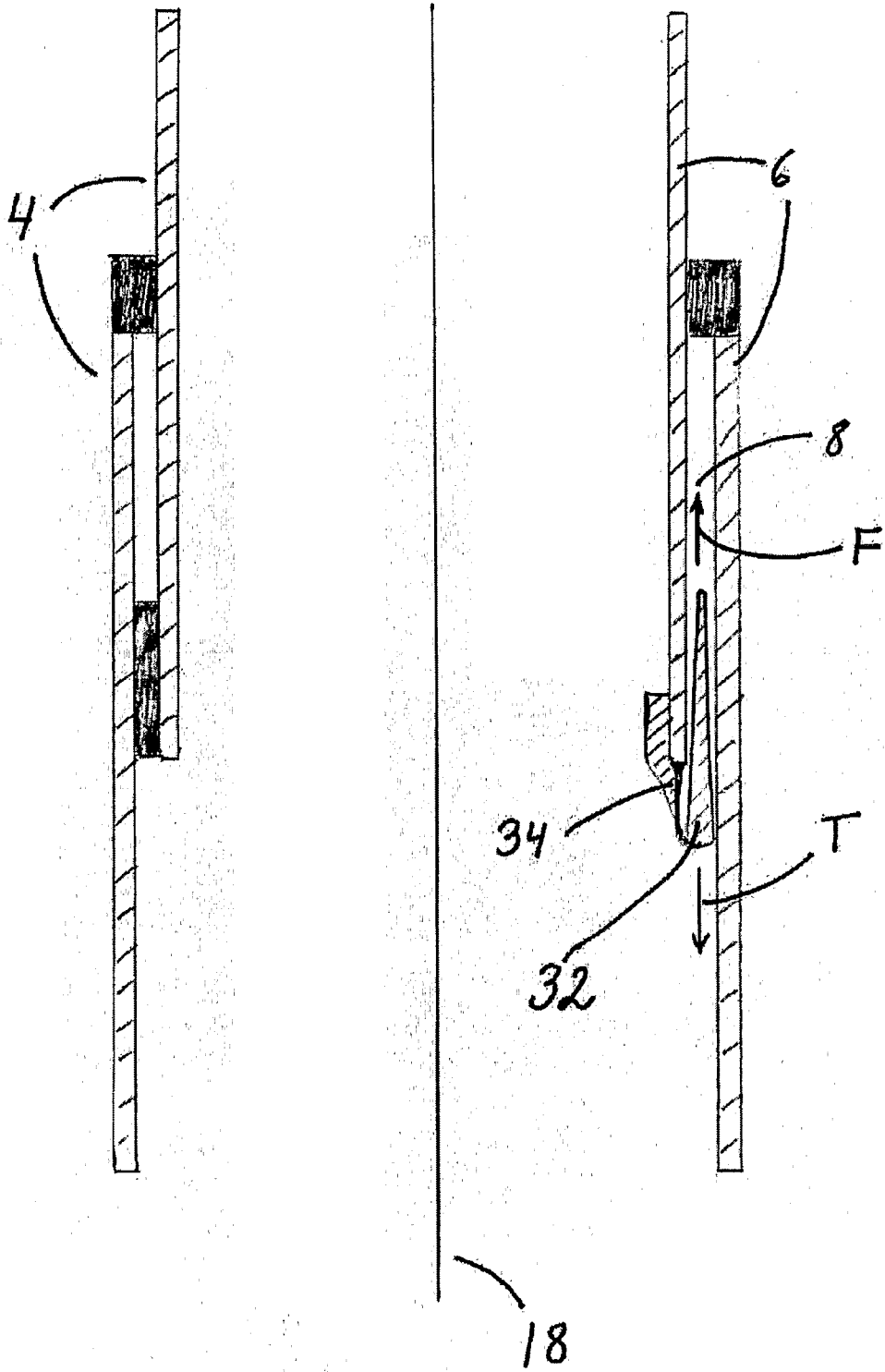

FIG. 4

INTERNATIONAL SEARCH REPORT

International application No.

PCT/DK2007/000401

A. CLASSIFICATION OF SUBJECT MATTER

IPC: see extra sheet

According to International Patent Classification (IPC) or to both national classification and IPC

B. FIELDS SEARCHED

Minimum documentation searched (classification system followed by classification symbols)

IPC: F16B, H01Q

Documentation searched other than minimum documentation to the extent that such documents are included in the fields searched

SE,DK,FI,NO classes as above

Electronic data base consulted during the international search (name of data base and, where practicable, search terms used)

EPO-INTERNAL, WPI DATA, PAJ

C. DOCUMENTS CONSIDERED TO BE RELEVANT

Category*	Citation of document, with indication, where appropriate, of the relevant passages	Relevant to claim No.
X	EP 0730098 A1 (BARTINGALE, PETER), 4 Sept 1996 (04.09.1996), column 1, line 1 - line 7; column 1, line 27 - line 51; column 2, line 55 - column 3, line 33, figures 1-9, abstract, column 4, line 8 - line 12; column 4, line 24 - line 29 --	1,3,6
X	US 6152638 A (LINDSAY), 28 November 2000 (28.11.2000), column 1, line 66 - column 2, line 12; column 2, line 46 - column 3, line 21, figures 1-3, abstract --	1,4
A	CA 904530 A (CANADA NATURAL RESOURCES), 11 July 1972 (11.07.1972), figures 1-3 --	1-7

 Further documents are listed in the continuation of Box C.
 See patent family annex.

* Special categories of cited documents:	"T" later document published after the international filing date or priority date and not in conflict with the application but cited to understand the principle or theory underlying the invention
"A" document defining the general state of the art which is not considered to be of particular relevance	"X" document of particular relevance: the claimed invention cannot be considered novel or cannot be considered to involve an inventive step when the document is taken alone
"E" earlier application or patent but published on or after the international filing date	"Y" document of particular relevance: the claimed invention cannot be considered to involve an inventive step when the document is combined with one or more other such documents, such combination being obvious to a person skilled in the art
"L" document which may throw doubts on priority claim(s) or which is cited to establish the publication date of another citation or other special reason (as specified)	"&" document member of the same patent family
"O" document referring to an oral disclosure, use, exhibition or other means	
"P" document published prior to the international filing date but later than the priority date claimed	

Date of the actual completion of the international search

23 January 2008

Date of mailing of the international search report

30-01-2008

 Name and mailing address of the ISA/
 Swedish Patent Office
 Box 5055, S-102 42 STOCKHOLM
 Facsimile No. +46 8 666 02 86

Authorized officer

 Marianne Dickman / JA A
 Telephone No. +46 8 782 25 00

INTERNATIONAL SEARCH REPORT

International application No.

PCT/DK2007/000401

C (Continuation). DOCUMENTS CONSIDERED TO BE RELEVANT		
Category*	Citation of document, with indication, where appropriate, of the relevant passages	Relevant to claim No.
A	US 4151534 A (BOND), 24 April 1979 (24.04.1979), column 1, line 5 - line 32; column 2, line 27 - line 40; column 3, line 16 - line 29 --	1-7
A	US 5218375 A (HILLMAN), 8 June 1993 (08.06.1993), column 1, line 51 - column 2, line 28; column 4, line 16 - line 38, figures 1-20, claims 1,5, abstract --	1,6
A	US 4062156 A (ROTH), 13 December 1977 (13.12.1977), column 2, line 10 - line 42, figures 1-2 -- -----	1,4,7

International patent classification (IPC)**H01Q 1/12** (2006.01)**F16B 7/14** (2006.01)**H01Q 1/10** (2006.01)**Download your patent documents at www.prv.se**

The cited patent documents can be downloaded at www.prv.se by following the links:

- In English/Searches and advisory services/Cited documents (service in English) or
- e-tjänster/anförda dokument (service in Swedish).

Use the application number as username.

The password is **ECAAPTKJRY**.

Paper copies can be ordered at a cost of 50 SEK per copy from PRV InterPat (telephone number 08-782 28 85).

Cited literature, if any, will be enclosed in paper form.

INTERNATIONAL SEARCH REPORT

Information on patent family members

29/12/2007

International application No.

PCT/DK2007/000401

EP	0730098	A1	04/09/1996	GB	9504291 D	00/00/0000
US	6152638	A	28/11/2000	AU	709650 B	02/09/1999
				AU	1453397 A	19/11/1997
				CN	1080400 B,C	06/03/2002
				CN	1222961 A	14/07/1999
				DE	19781733 T	08/04/1999
				GB	2331697 A,B	02/06/1999
				GB	9608945 D	00/00/0000
				GB	9823051 D	00/00/0000
				JP	3450860 B	29/09/2003
				JP	2000504095 T	04/04/2000
				WO	9741383 A	06/11/1997
CA	904530	A	11/07/1972	NONE		
US	4151534	A	24/04/1979	NONE		
US	5218375	A	08/06/1993	NONE		
US	4062156	A	13/12/1977	CA	1045330 A	02/01/1979
				DE	2603488 A,B,C	04/08/1977
				GB	1512912 A	01/06/1978