

(12) **United States Patent**
Veasey et al.

(10) **Patent No.:** **US 10,201,661 B2**
(45) **Date of Patent:** **Feb. 12, 2019**

(54) **PEN-TYPE INJECTOR**

(75) Inventors: **Robert Frederick Veasey**,
Warwickshire (GB); **Christopher Nigel
Langley**, Warwickshire (GB); **Steven
Wimpenny**, Warwickshire (GB)

(73) Assignee: **Sanofi-Aventis Deutschland GMBH**,
Frankfurt am Main (DE)

(*) Notice: Subject to any disclaimer, the term of this
patent is extended or adjusted under 35
U.S.C. 154(b) by 40 days.

(21) Appl. No.: **13/208,486**

(22) Filed: **Aug. 12, 2011**

(65) **Prior Publication Data**

US 2011/0301550 A1 Dec. 8, 2011

Related U.S. Application Data

(60) Division of application No. 12/900,725, filed on Oct.
8, 2010, now Pat. No. 8,021,345, which is a
(Continued)

(30) **Foreign Application Priority Data**

Mar. 3, 2003 (GB) 0304823.8

(51) **Int. Cl.**

A61M 5/315 (2006.01)
A61M 5/24 (2006.01)

(52) **U.S. Cl.**

CPC **A61M 5/31528** (2013.01); **A61M 5/3155**
(2013.01); **A61M 5/31533** (2013.01);
(Continued)

(58) **Field of Classification Search**

CPC A61M 5/31528; A61M 5/3155; A61M
5/31551; A61M 5/31533; A61M 5/31563;
A61M 5/31578; A61M 5/31593
(Continued)

(56) **References Cited**

U.S. PATENT DOCUMENTS

533,575 A 2/1895 Wilkens
4,865,591 A 9/1989 Sams
(Continued)

FOREIGN PATENT DOCUMENTS

CA 2138528 C 12/1998
CA 2359375 A1 7/2000
(Continued)

OTHER PUBLICATIONS

“Pan-injectors for medical use—Part 1: Pen-injectors—
Requirements and test methods,” International Standard, reference
No. ISO 11608-1:2000(E), first edition Dec. 15, 2000, 32 pages.

Primary Examiner — Shefali D Patel

(74) *Attorney, Agent, or Firm* — Fish & Richardson P.C.

(57) **ABSTRACT**

The present invention relates to injectors, such as pen-type
injectors, that provide for administration of medicinal prod-
ucts from a multidose cartridge and permit a user to set a
delivery dose. An injector may include a housing, a cartridge
containing a medicinal product, the cartridge being retained
within the housing, a dose setting mechanism to select a
dose of the medicinal product to be expelled, and a dose
delivery mechanism to expel the selected dose of the medi-
cinal product. The housing may be a unitary housing within
which the dose setting mechanism and the dose delivery
mechanism are moveably retained.

12 Claims, 6 Drawing Sheets

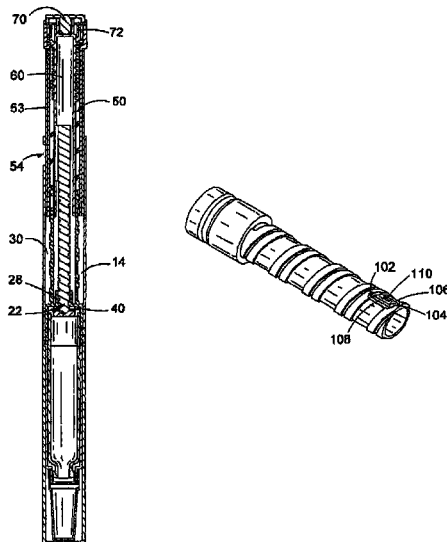

Related U.S. Application Data

continuation of application No. 10/790,025, filed on Mar. 2, 2004, now Pat. No. 7,905,867.

(52) **U.S. Cl.**

CPC *A61M 5/31551* (2013.01); *A61M 5/24* (2013.01); *A61M 5/2422* (2013.01); *A61M 5/3156* (2013.01); *A61M 5/31501* (2013.01); *A61M 5/31511* (2013.01); *A61M 5/31526* (2013.01); *A61M 5/31541* (2013.01); *A61M 5/31583* (2013.01); *A61M 5/31585* (2013.01); *A61M 5/31593* (2013.01); *A61M 2205/581* (2013.01); *A61M 2205/582* (2013.01)

(58) **Field of Classification Search**

USPC 604/207, 208, 209, 210, 211
See application file for complete search history.

(56)

References Cited

U.S. PATENT DOCUMENTS

5,092,842	A	3/1992	Bechtold et al.
5,226,895	A	7/1993	Harris
5,226,896	A	7/1993	Harris
5,279,586	A	1/1994	Balkwill
5,304,152	A	4/1994	Sams
5,320,609	A	6/1994	Haber et al.
5,378,233	A	1/1995	Haber et al.
5,383,865	A	1/1995	Michel
5,391,157	A	2/1995	Harris et al.
5,480,387	A	1/1996	Gabriel et al.
5,505,704	A	4/1996	Pawelka et al.
5,582,598	A	12/1996	Chanoch
5,584,815	A	12/1996	Pawelka et al.
5,626,566	A	5/1997	Petersen et al.
5,674,204	A	10/1997	Chanoch
5,679,111	A	10/1997	Hjertman et al.
5,688,251	A	11/1997	Chanoch
5,807,346	A	9/1998	Frezza
5,820,602	A	10/1998	Kovelman et al.
5,851,079	A	12/1998	Horstman et al.
5,921,966	A	7/1999	Bendek et al.
5,957,896	A	9/1999	Bendek et al.
5,961,495	A	10/1999	Walters et al.
6,004,297	A	12/1999	Steenfeldt-Jensen et al.
6,059,755	A	9/2000	Michel
6,193,698	B1	2/2001	Kirchhofer et al.
6,221,046	B1*	4/2001	Burroughs et al. 604/153

6,235,004	B1	5/2001	Steenfeldt-Jensen et al.
6,248,095	B1	6/2001	Giambattista et al.
6,562,006	B1	5/2003	Hjertman et al.
6,613,023	B2	9/2003	Kirchhofer et al.
6,699,224	B2	3/2004	Kirchhofer et al.
6,899,698	B2	5/2005	Sams
6,932,794	B2	8/2005	Giambattista et al.
6,936,032	B1	8/2005	Bush, Jr. et al.
7,169,132	B2	1/2007	Bendek et al.
7,241,278	B2	7/2007	Moller
7,678,084	B2	3/2010	Judson et al.
7,850,662	B2	12/2010	Veasey et al.
8,187,233	B2	5/2012	Harms et al.
2002/0052578	A1*	5/2002	Moller A61M 5/24 604/208
2002/0120235	A1	8/2002	Enggaard
2002/0165499	A1	11/2002	Slate et al.
2003/0050609	A1	3/2003	Sams
2004/0059299	A1	3/2004	Moller
2004/0097883	A1	5/2004	Roe
2004/0210199	A1	10/2004	Atterbury et al.
2004/0267207	A1	12/2004	Veasey et al.
2005/0113765	A1	5/2005	Veasey et al.
2006/0153693	A1	7/2006	Fiechter et al.
2007/0016143	A1	1/2007	Miller et al.
2009/0275916	A1	11/2009	Harms et al.

FOREIGN PATENT DOCUMENTS

EP	0496141	A1	7/1992
EP	0897729	A2	2/1999
EP	0937471		8/1999
EP	0937476	A2	8/1999
EP	0937477		8/1999
EP	1776975	A2	4/2007
WO	91/14467		10/1991
WO	93/07922	A1	4/1993
WO	93/24160	A1	12/1993
WO	96/25965		8/1996
WO	99/38554		8/1999
WO	99/38554	A1	8/1999
WO	01/10484		2/2001
WO	02/30495	A2	4/2002
WO	02/053214		7/2002
WO	02/092153		11/2002
WO	02/092153	A2	11/2002
WO	WO 02092153	A2*	11/2002 A61M 5/31535
WO	03/080160		10/2003
WO	03/080160	A1	10/2003
WO	2006/084876	A1	8/2006

* cited by examiner

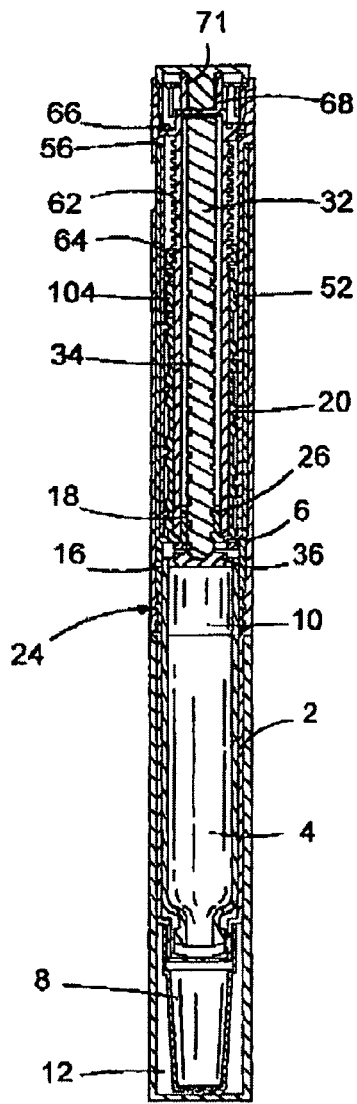

FIG. 1

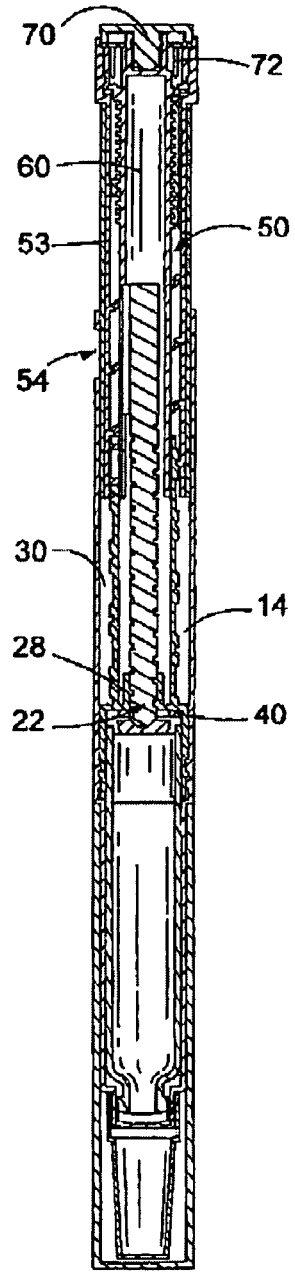

FIG. 2

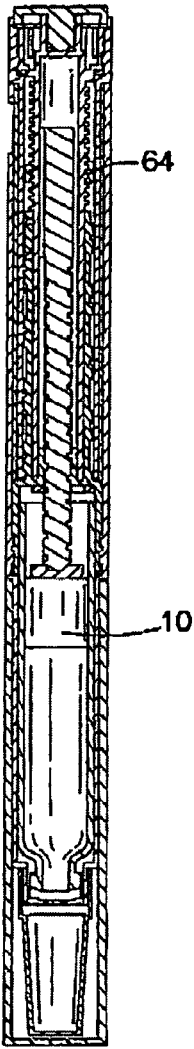

FIG. 3

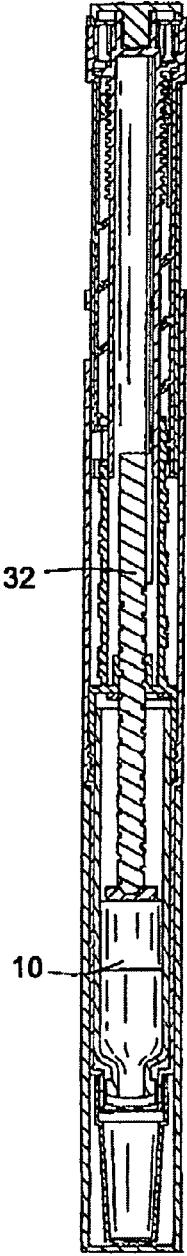

FIG. 4

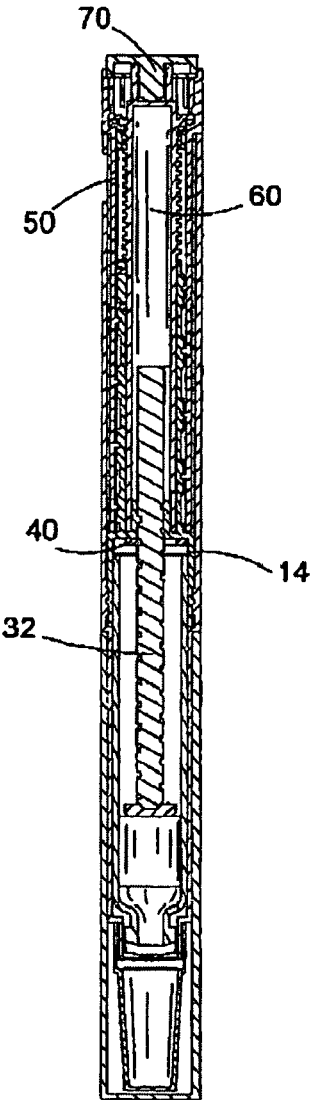

FIG. 5

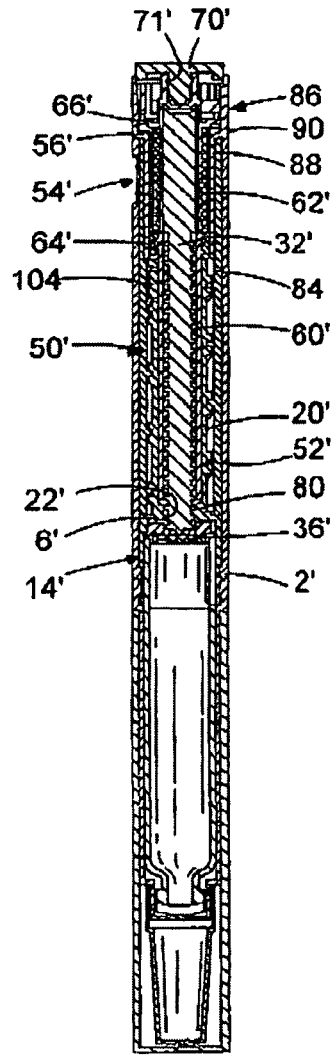

FIG. 6

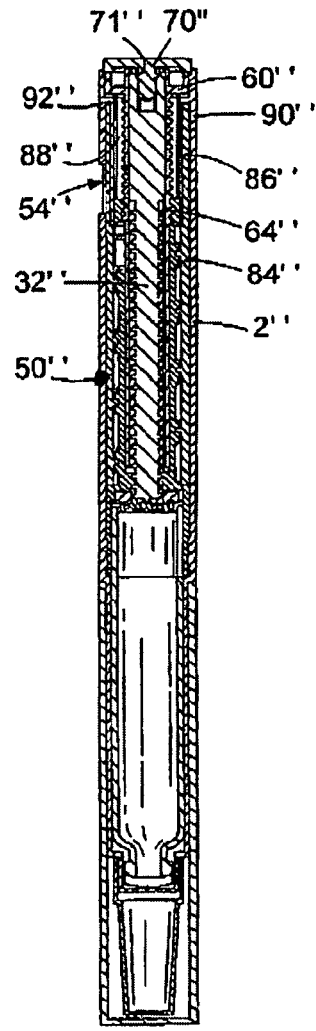
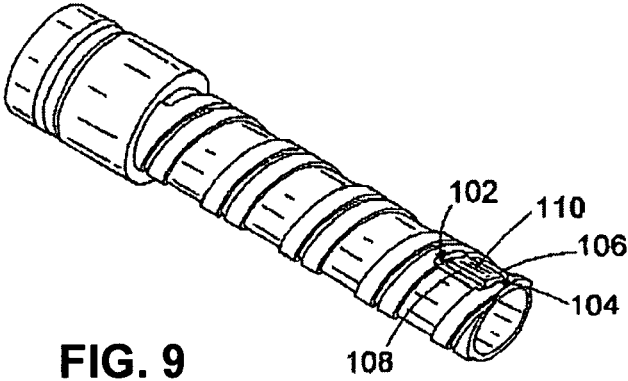
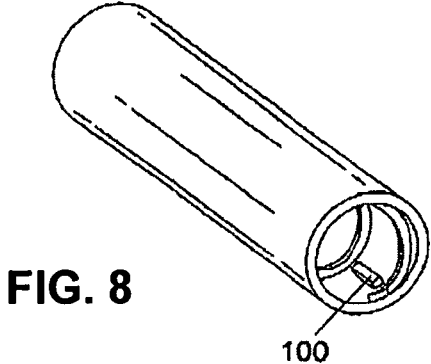

FIG. 7



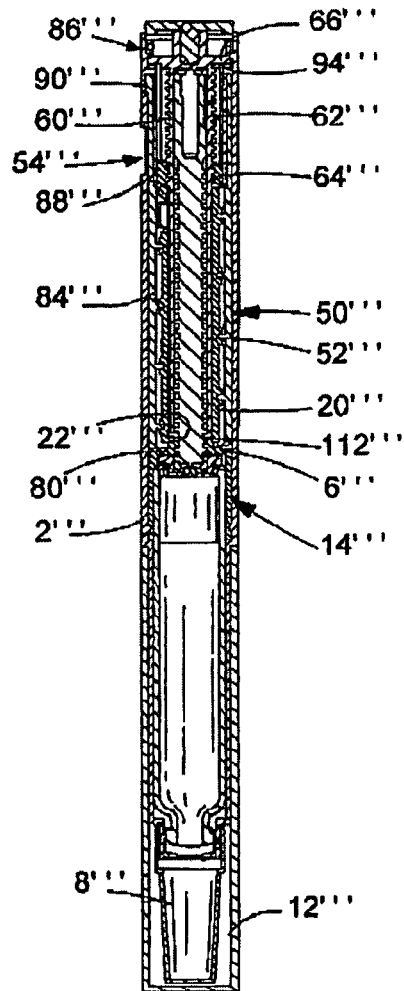

FIG. 10

PEN-TYPE INJECTORCROSS REFERENCE TO RELATED
APPLICATIONS

This application is a divisional of U.S. patent application Ser. No. 12/900,725, filed on Oct. 8, 2010, now U.S. Pat. No. 8,021,345, which is a continuation of U.S. patent application Ser. No. 10/790,025, filed on Mar. 2, 2004, now U.S. Pat. No. 7,905,867, which claims priority to Great Britain Patent Application No. 0304823.8, filed on Mar. 3, 2003, the entire contents of which are incorporated herein by reference.

BACKGROUND

The present invention relates to pen-type injectors, that is to injectors of the kind that provide for administration by injection of medicinal products from a multidose cartridge. In particular, the present invention relates to such injectors where a user may set the dose.

Such injectors have application where regular injection by persons without formal medical training occurs. This is increasingly common amongst those having diabetes where self-treatment enables such persons to conduct effective management of their diabetes.

These circumstances set a number of requirements for pen-type injectors of this kind. The injector must be robust in construction, yet easy to use both in terms of the manipulation of the parts and understanding by a user of its operation. In the case of those with diabetes, many users will be physically infirm and may also have impaired vision. Where the injector is to be disposable rather than reusable, the injector should be cheap to manufacture and easy to dispose of (preferably being suitable for recycling).

SUMMARY

It is an advantage of the present invention that an improved pen-type injector is provided.

According to first aspect of the present invention, a pen-type injector comprises a housing;

a cartridge containing medicinal product, the cartridge being retained within the housing;

means for selecting a dose of medicinal product to be expelled; means for expelling the selected dose of medicinal product;

characterised in that the housing comprises a unitary housing within which the dose selecting means and the dose expelling means are moveably retained.

It is an advantage of this aspect of the invention that it affords a more robust construction of a pen-type injector.

According to a second aspect of the present invention, a pen-type injector comprises

a piston rod having a screw thread;

an insert located in the housing and through which the piston may rotate; ratchet means associated with the insert to ensure the piston only rotates in a single direction through the insert;

a dose dial sleeve rotatable with respect to the housing and the insert;

a drive sleeve which is axially displaceable but not rotatable with respect to the piston rod;

a button located on the drive sleeve and rotatable with respect to the drive sleeve; and

clutch means which upon depression of the button prevents rotation between the dose dial sleeve and the drive sleeve.

Preferably, the injector further comprises a nut rotatable with respect to the drive sleeve and axially displaceable but not rotatable with respect to the dose dial sleeve.

Preferably, the insert comprises a web having an opening, a first cylindrical portion extending from a first side of the web, a second cylindrical portion extending from a second side of the web and a third cylindrical portion extending from a second side of the web.

Alternatively, the insert comprises a web having an opening, a first cylindrical portion extending from a first side of the web, a boss provided on a second side of the web and a cylindrical portion extending away from the web about a periphery of the boss.

In a second alternative, the insert comprises a web having an opening, a first cylindrical portion extending from a first side of the web, a boss provided on a second side of the web, a radial flange extending from the boss, the radial flange being spaced from the web, and a cylindrical portion extending away from the web about a periphery of the radial flange.

Preferably, the dose dial sleeve comprises a first section of first diameter and a second section of second diameter, the insert and an inner surface of the first section being provided with inter-engaging features to provide a helical thread between the insert and the dose dial sleeve.

Alternatively the dose dial sleeve comprises a first cylindrical portion rigidly connected to a second generally cylindrical portion, an inner surface of the first section and an outer surface of the cylindrical portion of the insert are provided with inter-engaging features to provide a helical thread between the insert and the dose dial sleeve.

More preferably, the second generally cylindrical portion comprises a first cylindrical section and a second cylindrical section connected by a shoulder, the first section being rigidly keyed to an inner surface of the first portion of the dose dial sleeve, and the second section being of the same outer diameter as the housing.

Alternatively the second generally cylindrical portion comprises a first cylindrical section and a second cylindrical section connected by a radial flange extending from a part of the second section, the first section being rigidly keyed to an inner surface of the first portion of the dose dial sleeve, and the second section being of the same outer diameter as the housing.

Preferably, an outer surface of the dose dial sleeve is provided with graphics and the housing is provided with an aperture or window through which a portion of the graphics may be viewed.

Preferably, the drive sleeve comprises a first part of first diameter located between the insert and the piston rod and a second part of second diameter located between the piston rod and the dose dial sleeve, an internal surface of the drive sleeve being splined to the piston rod such that no relative rotation may occur between these parts, only longitudinal displacement.

More preferably, the central receiving area includes at a first end a centrally located domed part.

Preferably, the nut is provided on a helical thread provided on the drive sleeve and is located between the drive sleeve and the dose dial sleeve, the dose dial sleeve and the nut being splined together by spline means to prevent relative rotation between the nut and the dose dial sleeve.

Preferably, the drive sleeve further comprises a central receiving area having a peripheral recess, the button being of generally "T" shaped configuration has a stem that is retained within the receiving area by co-operation between a peripheral bead provided on the stem retained in a peripheral recess provided in the central receiving area.

3

More preferably the second end of the piston rod is generally U-shaped, each of the limbs of the U-shape being received within a second part of the drive sleeve.

Preferably, the clutch means comprises a plurality of radially extending longitudinally directed teeth provided respectively on the dose dial sleeve and the drive sleeve.

Preferably, clicker means are provided between the dose dial sleeve and the drive sleeve, the clicker means comprising a plurality of longitudinally extending teeth and a flexible toothed member, one of the plurality of teeth and the toothed member being provided on the dose dial sleeve, the other being provided on the drive sleeve, relative rotation between the dose dial sleeve and the drive sleeve causing the flexible toothed member to ride over the teeth to produce a series of clicks.

According to a third aspect of the present invention, a pen-type injector comprises a housing;

a piston rod having a screw thread;

an insert located in the housing and through which the piston may rotate;

a dose dial sleeve rotatable with respect to the housing and the insert; and

a drive sleeve which is axially displaceable with respect to the housing;

characterized in that a maximum angular displacement of the dose dial sleeve with respect to the housing is determined by abutment of a radially directed lug on the dose dial sleeve with a catch means on the insert.

Preferably, the radially directed lug extends parallel to a longitudinal axis of the dose dial sleeve.

Preferably, the catch means comprises a groove extending about a central land, the central land being wedge shaped such that a first edge extends radially less far than a second opposite edge to define a sloping surface between the first edge and the second edge.

BRIEF DESCRIPTION OF THE FIGURES

The invention will now be described, by way of example only, with reference to the accompanying drawings, in which:

FIG. 1 shows a sectional side view of a first embodiment of an injector in accordance with the present invention in a first position;

FIG. 2 shows a sectional side view of the injector of FIG. 1 in a second position;

FIG. 3 shows a sectional side view of the injector of FIG. 1 in a third position;

FIG. 4 shows a sectional side view of the injector of FIG. 1 in a fourth position;

FIG. 5 shows a sectional side view of the injector of FIG. 1 in a second position;

FIG. 6 shows a sectional side view of a second embodiment of an injector in accordance with the present invention;

FIG. 7 shows a sectional side view of a third embodiment of an injector in accordance with the present invention;

FIG. 8 shows a perspective view of a dose dial sleeve for use in conjunction with the present invention;

FIG. 9 shows a perspective view of an insert for use with the dose dial sleeve of FIG. 8; and

FIG. 10 shows a sectional side view of a fourth embodiment of an injector in accordance with the present invention.

DETAILED DESCRIPTION

Referring first to FIGS. 1 to 5 there may be seen an injector in accordance with a first embodiment of the present

4

invention. The injector comprises a housing 2 within which are located a cartridge 4 containing a medicinal product, means for setting or selecting the dose of medicinal product to be expelled and means for expelling the selected dose of medicinal product. The housing 2 is generally cylindrical in shape and is divided into two compartments by a web 6 to be described in more detail below. The cartridge 4 is located within a first part of the housing 2. The dose setting means and the means for expelling the selected dose of medicinal product are retained, that is held, within a second part of the housing 2. An advantage of a one piece housing enclosing the cartridge 4 together with the dose setting and dose expelling means lies in the ease of assembly of the product. This is in part due to the reduced number of components in the pen-type injector. Also, the unitary nature of the housing 2 means that the pen-type injector is more robust.

The cartridge 4 may be secured in position in the first part of the housing 2 by any suitable means. A needle unit may be secured to a first end of the cartridge 4. A temporary covering 8 is shown in this position in the Figures. The cartridge 4 further comprises a displaceable piston 10.

Advancing the piston 10 towards the first end of the cartridge 4 causes the medicinal product to be expelled from the cartridge 4 through the needle unit. A cap 12 is provided to cover the needle unit when the injector is not in use. The cap 12 may be releasably secured to the housing 2 by any suitable means.

The dose setting means and the means for expelling the selected dose of medicinal product will now be described in more detail. The web 6 dividing the housing 2 is a part of an insert 14 located within the housing 2. The insert 14 comprises a first cylindrical portion 16 extending from a first side of the web 6 and second and third cylindrical portions 18, 20 extending from a second side of the web 6. The web 6 is provided with a circular opening 22 extending through the web 6.

The first cylindrical portion 16 extends from a periphery of the web 6. The insert 14 is secured to the housing 2 by way of the first cylindrical portion 16 by any suitable means. In the illustrated embodiment features 24 are provided within the housing 2 and on an outer surface of the first cylindrical portion 16 to enable the insert to be a snap fit to the housing 2.

The second cylindrical portion 18 extends a small distance from the second side of the web 6 about a periphery of the opening 22. An internal surface of the second cylindrical portion is provided with a screw thread 26.

The third cylindrical portion 20 extends substantially within the housing 2 from the second side of the web 6. The diameter of the third cylindrical portion 20 is such that a first channel 28 is formed between an outer surface of the second cylindrical portion 20 and an inner surface of the third cylindrical portion. A second channel 30 is formed between an outer surface of the third cylindrical portion 20 and the housing 2.

A piston rod 32 is provided extending through the opening in the web 6. The piston rod 32 is generally elongate and is provided with a screw thread 34 extending from a first end of the piston rod 32. The screw thread 34 of the piston rod 32 engages the screw thread of the inner surface of the second cylindrical portion 18 of the insert 14. The first end of the piston rod 32 is provided with a pressure foot 36. In use the pressure foot 36 is disposed on the first side of the web 6 to abut the cartridge piston 10.

Ratchet means 40 are located adjacent the web 6 on the first side of the web 6. The ratchet means 40 serve the purpose of allowing the piston rod 32 only to rotate through

5

the insert **14** in a single direction. Due to the one piece construction of the housing, the ratchet means can be made larger than in known devices and so is stronger (more rigid).

A dose dial sleeve **50** of generally cylindrical form comprises a first section of first diameter and a second section of second diameter. The first section is located within the second channel **30**. An inner surface of the first section and the outer surface of the third cylindrical portion **20** are provided with inter-engaging features to provide a helical thread **52** between the insert **14** and the dose dial sleeve **50**. Conveniently as in the illustrated embodiment, this is achieved by a helical track provided on the outer surface of the third cylindrical portion **20** within which a helical rib provided on the inner surface of the dose dial sleeve **50** may run. This enables the dose dial sleeve **50** to rotate about and along the third cylindrical portion **20** of the insert **14**.

An outer surface of the first section of the dose dial sleeve **50** is provided with graphics **53**. The graphics are typically a sequence of reference numerals. The housing **2** is provided with an aperture or window **54** through which a portion of the graphics, representing a dosage value selected by the user, may be viewed.

The graphics **53** may be applied to the dose dial sleeve **50** by any suitable means. In the illustrated embodiment, the graphics **53** are provided in the form of a printed label encircling the dose dial sleeve **50**. Alternatively the graphics may take the form of a marked sleeve clipped to the dose dial sleeve **50**. The graphics may be marked in any suitable manner, for example by laser marking.

It is an advantage of this arrangement that the helical thread **52** is formed within the dose dial sleeve between the dose dial sleeve and the insert. As can be seen this means there is no direct route from outside the injector to the working surfaces of the helical thread. Should dust or dirt enter the pen this will tend to occur between the housing and the dose dial sleeve where there are no working parts with which to interfere. This is not the case for known devices in which a helical thread is formed between the housing and an interior moving surface. In addition because of the narrower diameter of the helical thread **52** formed between the dose dial sleeve and the drive sleeve in comparison to a similar thread formed between the housing and the dose dial sleeve, the helical thread **52** is more efficient and easier to overhaul. This arrangement also produces an improvement in the dose size that can be delivered for a particular linear travel of the dose expelling means.

The second section of the dose dial sleeve **50** is preferably of the same outer diameter as the housing **2**. Within the dose dial sleeve **50** there is a shoulder **56** between the first section of the dose dial sleeve **50** and the second section of the dose dial sleeve **50**.

A drive sleeve **60** of generally cylindrical form comprises a first part of first diameter and a second part of second diameter. A first end of the first part is located within the first channel **28** of the insert **14** in the position shown in FIG. 1. The first part of the drive sleeve **60** may be considered as comprising a first portion aligned with a second portion. More generally in the position shown in FIG. 1 the first portion of the drive sleeve **60** is located between the insert **14** and the piston rod **32** while the second portion is located between the piston rod **32** and the dose dial sleeve **60**.

A second end of the piston rod **32** and an internal surface of the drive sleeve **60** are splined together such that no relative rotation may occur between these parts, only longitudinal displacement.

The outer surface of the second portion of the first part of the drive sleeve **60** is provided with a helical thread **62**. A nut

6

64 is provided on the helical thread **62** between the drive sleeve **60** and the dose dial sleeve **50**. The dose dial sleeve **50** and the nut **64** are splined together by spline means to prevent relative rotation between the nut **64** and the dose dial sleeve **50**.

The second part of the drive sleeve **60** is of larger diameter than the first part of the drive sleeve **60**. There is a step **66** between the first part of the drive sleeve **60** and the second part. The second part of the drive sleeve **60** is seated within the second section of the dose dial sleeve **50**. The shoulder **56** of the dose dial sleeve **50** and the step **66** of the drive sleeve **60** are adapted to be releasably engagable with one another to form a clutch means. When, as in FIG. 1, the dose dial sleeve **50** and the drive sleeve **60** are not in engagement the dose dial sleeve **50** is able to rotate with respect to the drive sleeve **60**. Conveniently, the clutch means comprises a plurality of radially extending longitudinally directed teeth provided respectively on the shoulder **56** of the dose dial sleeve **50** and the step **66** of the drive sleeve **60**. When the dose dial sleeve **50** and the drive sleeve **60** are not forced together the respective teeth will ride over one another. Preferably, the radial separation of the respective teeth corresponds to a unit dosage.

The second part of the drive sleeve **60** further comprises a central receiving area **68** having a peripheral recess. A button **70** of generally "T" shaped configuration is provided, the stem of which is retained within the receiving area. The stem of the button **70** is provided with a peripheral bead **71** that is retained in the peripheral recess, the button **70** being able freely to rotate with respect to the drive sleeve **60**, but being retained axially therewith.

Clicker means are provided between the second section of the dose dial sleeve **50** and the second part of the drive sleeve **60**. In the illustrated embodiment, the internal surface of the second section of the dose dial sleeve **50** is provided with a plurality of longitudinally extending teeth. The radial separation of the teeth preferably corresponds to a unit dosage. The second part of the drive sleeve **60** carries a flexible toothed member **72**. Relative rotation between the dose dial sleeve **60** and the drive sleeve **60** will cause the flexible toothed member **72** to ride over the teeth to produce a series of clicks.

In FIG. 1, the injector is provided with a filled cartridge **4**. To operate the injector a user must first select a dose. To set a dose the dose dial sleeve **50** is rotated by manipulating the second section of the dose dial sleeve **50** with respect to the housing **2** until the desired dose value is visible through the window **54**. This action draws the dose dial sleeve **60** along the second cylindrical portion of the insert **14**. The drive sleeve **60** cannot rotate since it is splined to the piston rod **32**. The piston rod **32** does not rotate due to the action of the ratchet means **40**. The drive sleeve **60** is carried away from the web **6** along the piston rod **32** by the dose dial sleeve **50** as the dose dial sleeve **50** moves out from the housing **2**. The relative rotation between the dose dial sleeve **50** and the drive sleeve **60** causes the flexible toothed member **72** to ride over the ridges in the drive sleeve **60** to create a series of clicks. This is an audible confirmation of the dose being dialed.

Since the nut **64** is splined to the dose dial sleeve **50**, the relative rotation between the dose dial sleeve **50** and the drive sleeve **60** causes the nut **64** to progress along the helical thread **62** of the drive sleeve **60**.

Once a desired dose has been set (as shown for example in FIG. 2), to deliver the dose the user depresses the button **70** to urge the button **70** towards the first end of the housing **2**. When the button **70** is depressed the second part of the

drive sleeve 60 is driven into the second section of the dose dial sleeve 50 to engage the clutch means therebetween to prevent relative rotation between the dose dial sleeve 50 and the drive sleeve 60. The drive sleeve 60 may still rotate with respect to the button 70. Further longitudinal movement of the button 70 causes the dose dial sleeve 50 (together with the drive sleeve 60) to rotate towards the first end of the injector. Since the piston rod 32 is splined to the drive sleeve 60, the piston rod 32 is also rotated through the insert 14 and the ratchet means 40 towards the first end of the injector, thereby to advance the cartridge piston 10 and expel the desired dose of medicinal product. The piston rod 32 continues to advance until the drive sleeve 60 and dose dial sleeve 50 have returned to their initial positions (FIG. 3).

It can be seen that the dose selecting means and the dose expelling means extend beyond a second end of the housing 2 as the dose is selected and are returned within the housing 2 as the selected dose is expelled.

Further dosages may be delivered as required. FIG. 4 shows an example of a subsequently selected dosage. It will be noted that the nut 64 has advanced further along the helical thread 62 of the drive sleeve 60. The position of the nut 64 along the helical thread 62 corresponds to the amount of medicinal product remaining in the cartridge 4, such that when the nut 64 reaches the end of the helical thread 62 (in the illustrated embodiment adjacent to the step 66 of the drive sleeve 60) and can rotate no further this corresponds to no medicinal product remaining in the cartridge 4. It will be seen that if a user seeks to select a quantity of medical product greater than that remaining in the cartridge 4, this cannot be done since when the nut 64 stops rotating the dose dial sleeve 50 and the drive sleeve 60 will become locked together preventing rotation of the dose dial sleeve 50 and setting of a larger dose. FIG. 5 shows an injector according to the present invention in which the entire medical product within the cartridge 4 has been expelled.

A second embodiment of the present invention is disclosed in FIG. 6. Like reference numerals are used to refer to like parts as between the first and second embodiments.

The piston rod 32' shown in FIG. 6 has a dual start thread. The piston foot 36' is reversible. This has advantages in manufacture. As can be seen the structure of the insert 14' has been revised. The first side of the web 6' is substantially unchanged. The other side of the web is now provided with a boss 80. A cylindrical portion 20' extends away from the web 6' about a periphery of the boss 80. Threaded opening 22' extends through the web 6' and the boss 80. An end of the cylindrical portion 20' of the insert 14' remote from the web 6' is provided with a stop in the form of a land 104.

The dose dial sleeve 50' is of modified construction. The dose dial sleeve comprises a first cylindrical portion 84 rigidly connected to a second generally cylindrical portion 86. An inner surface of the first cylindrical portion 84 and the outer surface of the cylindrical portion 20' of the insert 14' are provided with interengaging features to provide a helical thread 52' between the insert 14' and the dose dial sleeve 50'. An outer surface of the first cylindrical portion 84 is provided with the dose graphics. The housing 2' is provided with an aperture or window 54' through which a portion of the graphics may be viewed.

The second generally cylindrical portion 86 comprises a first cylindrical section 88 and a second cylindrical section 90. The first section 88 is rigidly keyed to an inner surface of the first portion 84 of the dose dial sleeve 50'. The second section 90 is preferably of the same outer diameter as the housing 2'. Within the dose dial sleeve 50' there is a shoulder 56' between the first section 86 and the second section 90.

A nut 64' is provided on the helical thread 62' between the drive sleeve 60' and the first cylindrical section 88 of the dose dial sleeve 50'. The first cylindrical section 88 and the nut 64' are splined together by spline means to prevent relative rotation between the nut 64' and the dose dial sleeve 50'.

The shoulder 56' of the dose dial sleeve 50' and a step 66' of a drive sleeve 60' are adapted to be releasably engagable with one another to form a clutch means. When, as in FIG. 6, the dose dial sleeve 50' and the drive sleeve 60' are not in engagement the dose dial sleeve 50' is able to rotate with respect to the drive sleeve 60'. Conveniently, the clutch means comprises a plurality of radially extending longitudinally directed teeth provided respectively on the shoulder 56' of the dose dial sleeve 50' and the step 66' of the drive sleeve 60'. When the dose dial sleeve 50' and the drive sleeve 60' are not forced together the respective teeth will ride over one another.

It will be seen that the structure of the drive sleeve 60' has also been modified. The second end of the piston rod 32' is provided with a scooped surface within which a domed part 90 of the drive sleeve 60' may extend. The domed part 90 is centrally located within a second part of the drive sleeve 60' at a first end of the receiving area.

The button 70' is of generally "T" shaped configuration. The stem of the button 70' is retained within the receiving area. The stem of the button 70' is provided with a peripheral bead 71' that is retained in the peripheral recess, the button 70' being able freely to rotate with respect to the drive sleeve 60', but being retained axially therewith.

When the button 70' is depressed the drive sleeve 60' is urged into contact with the dose dial sleeve 50' such that the clutch means are engaged. At the same time, the scooped surface of the piston rod 32' and the domed surface of the drive sleeve approach but do not contact one another. The advantage of this structure is that it enables the overall length of the device to be reduced thereby enabling easier operation of the device when expressing fluid from a cartridge.

A further embodiment of the button 70" and the dose dial sleeve 50" can be seen in FIG. 7. Again like reference numerals are used to refer to like parts. In the embodiment of FIG. 7, the overall length of the device may be reduced still further. The second end of the piston rod 32" is generally U-shaped. The limbs of the U-shape are received within a second part of the drive sleeve 60". A central receiving area of the drive sleeve 60" is defined by limbs (not shown) located in use between the limbs formed on the second end of the piston rod 32". The button 70" is of generally "T" shaped configuration. The stem of the button 70" is retained within the receiving area. The stem of the button 70" is provided with a peripheral bead 71" that is retained in the peripheral recess, the button 70" being able freely to rotate with respect to the drive sleeve 60", but being retained axially therewith.

The second generally cylindrical portion 86" of the dose dial sleeve 50" comprises a first cylindrical section 88" and a second cylindrical section 90" connected by a radial flange 92 extending from a part of the second section, the first section 88" being rigidly keyed to an inner surface of the first portion 84" of the dose dial sleeve 50", and the second section 90" being of the same outer diameter as the housing 2".

In each of FIGS. 6 and 7, there is a further modification to each of the dose dial sleeve and the insert. This may be seen more clearly with reference to FIGS. 8 and 9.

At a first end of the dose dial sleeve there is located on an internal surface a radially directed lug 100 extending generally parallel to a longitudinal axis of the sleeve. At a second end of the insert on an external surface thereof there is provided a catch means. The catch means comprises a groove 102 extending about a central land 104. The central land 104 is generally wedge shaped such that a first edge 106 nearer the start of the thread extends radially less far than a second opposite edge 108 located further along the thread. A sloping surface 110 is defined between the first edge 106 and the second edge 108. Thus, when the dose dial sleeve is assembled to the insert, by threading the dose dial sleeve onto the insert, the lug 100 passes over the first edge 106 and over the sloping surface 110. As the lug 100 passes fully over the land 104 some elastic deformation of the respective elements, the dose dial sleeve and the insert occurs. Once the lug 100 is over the land 104, the second edge 108 of the land 104 acts as a stop to prevent removal of the dose dial sleeve from the insert.

The location of the second edge 108 of the land 104 is conveniently chosen at a radial location corresponding to 80 units of medicinal product, that is the maximum dose available is 80 units when the dose dial sleeve is wound from the initial position shown in any of FIG. 1, 6 or 7 to a fully extended position with the second edge 108 of the land 104 contacting the lug 100.

A fourth embodiment of the present invention is disclosed in FIG. 10. Like reference numerals are used to refer to like parts.

As can be seen the structure of the insert 14'' has been revised. The first side of the web 6'' is substantially unchanged. The other side of the web is now provided with a boss 80''. A radial flange 112 extends outwardly from the boss 80'', the radial flange 112 being spaced from the web 6'', and a cylindrical portion 20'' extending away from the web 6'' about a periphery of the radial flange 110. A threaded opening 22'' extends through the web 6'' and the boss 80''.

The dose dial sleeve 50'' is of modified construction. The dose dial sleeve 50'' comprises a first cylindrical portion 84'' rigidly connected to a second generally cylindrical portion 86''. An inner surface of the first portion 84'' and the outer surface of the cylindrical portion 20'' of the insert 14'' are provided with inter-engaging features to provide a helical thread 52'' between the insert 14'' and the dose dial sleeve 50''. An outer surface of the first cylindrical portion 84'' is provided with the dose graphics. The housing 2'' is provided with an aperture or window 54'' through which a portion of the graphics may be viewed.

The second generally cylindrical portion 86'' comprises a first inner cylindrical section 88'' and a second outer cylindrical section 90''. The first section 88'' is rigidly keyed to an inner surface of the first portion 84'' of the dose dial sleeve 50''. The second section 90'' is preferably of the same outer diameter as the housing 2''. Within the dose dial sleeve 50'' there is a radial flange 94 extending between the outer section 90'' and an intermediate part of the inner section 88''.

A nut 64'' is provided on a helical thread 62'' formed on the drive sleeve 60''. The nut 64'' is disposed between the drive sleeve 60'' and the second cylindrical section 88'' of the dose dial sleeve 50''. The second cylindrical section 88'' and the nut 64'' are keyed together by spline means to prevent relative rotation between the nut 64'' and the dose dial sleeve 50''.

An upper surface of the radial flange 94 of the dose dial sleeve 50'' and a step 66'' of the drive sleeve 60'' are adapted to be releasably engagable with one another to form

a clutch means. When, as in FIG. 10, the dose dial sleeve 50'' and the drive sleeve 60'' are not in engagement the dose dial sleeve 50'' is able to rotate with respect to the drive sleeve 60''. Conveniently, the clutch means comprises a plurality of radially extending longitudinally directed teeth provided respectively on the radial flange 94 of the dose dial sleeve 50'' and the step 66'' of the drive sleeve 60''. When the dose dial sleeve 50'' and the drive sleeve 60'' are not forced together the respective teeth will ride over one another.

The invention claimed is:

1. A pen-type injector, comprising:

- a housing;
- an insert located in and secured to the housing and having an external surface;
- a dose dial sleeve rotatable with respect to the housing and the insert;
- a drive sleeve which is axially displaceable with respect to the housing;
- a nut provided on a helical thread between the drive sleeve and the dose dial sleeve, the nut being rotatable with respect to the drive sleeve and axially displaceable, the nut not rotatable with respect to the dose dial sleeve; and
- a catch provided on the external surface of the insert, where the catch comprises a land and a groove, the land being positioned within the groove such that the groove extends from a first edge and a second edge of the land, where the second edge is positioned at a location corresponding to a maximum settable dose of the injector, and where a sloping surface is defined between the first edge and the second edge.

2. The injector of claim 1, further comprising a dose dial sleeve rotatable during dose delivery surrounding the insert, wherein a maximum angular displacement of the dose dial sleeve with respect to the housing during dose setting is determined by the catch.

3. The injector of claim 2 wherein the dose dial sleeve has an outside surface comprising graphics.

4. The injector of claim 1, wherein the land is wedge shaped.

5. The injector of claim 4, where a fully extended position of a dose dial sleeve that was wound from an initial position during dose setting corresponds to the maximum settable dose.

6. The injector of claim 1, wherein the first edge is opposite the second edge and the second edge extends radially from a longitudinal axis of the insert a greater distance than the first edge to define the sloping surface.

7. The injector of claim 1, further comprising a button configured to be pressed to deliver a set dose.

8. The injector of claim 1, further comprising a piston rod that rotates during dose delivery.

9. The injector of claim 1 wherein the insert has first, second and third cylindrical portions.

10. A pen-type injector, comprising:

- a housing;
- an insert located in and secured to the housing and having an external surface;
- a dose dial sleeve rotatable during dose delivery surrounding the insert, the dose dial sleeve comprising a radially directed lug on an internal surface;
- a drive sleeve which is axially displaceable with respect to the housing;
- a nut provided on a helical thread between the drive sleeve and the dose dial sleeve the nut being rotatable with

11

respect to the drive sleeve and axially displaceable, the nut not rotatable with respect to the dose dial sleeve; and

a catch located on the external surface of the insert, where the catch comprises a groove and a land, where the land comprises a first edge and a second edge, where the second edge acts as a stop that prevents rotation of the dose dial sleeve past a fully extended position when wound from an initial position during dose setting, engages the radially directed lug and prevents removal of the dose dial sleeve from the insert.

11. A pen-type injector comprising:

a housing;

an insert located in and secured to the housing and having an external surface;

a dose dial sleeve rotatable with respect to the housing and the insert;

a drive sleeve which is axially displaceable with respect to the housing;

a nut provided on a helical thread between the drive sleeve and the dose dial sleeve, the nut being rotatable with respect to the drive sleeve and axially displaceable, the nut not rotatable with respect to the dose dial sleeve; and

wherein the insert is provided with a catch located on the external surface, said catch comprising a groove

12

extending about a central land located in the groove, a location of an edge of said central land being chosen at a location corresponding to a maximum dose, and where the central land includes a sloping surface.

12. A pen-type injector comprising:

a housing;

a dose dial sleeve which is rotatable with respect to the housing to set a dose;

an insert located in and secured to the housing and having an external surface;

a drive sleeve which is axially displaceable with respect to the housing;

a nut provided on a helical thread between the drive sleeve and the dose dial sleeve, the nut being rotatable with respect to the drive sleeve and axially displaceable, the nut not rotatable with respect to the dose dial sleeve; and

wherein the insert comprises a catch located on the external surface, the catch comprising a groove extending about a central land located in the groove, said central land comprising comprises a first edge and a second edge, where the second edge a sloping surface that acts as a stop for the dose dial sleeve when the dose dial sleeve is wound from an initial position to a fully extended position.

* * * * *