

A. L. LADWIG & J. BUTKUS.

WINDOW SCREEN.

APPLICATION FILED AUG. 16, 1909.

Patented July 18, 1911.

3 SHEETS-SHEET 1.

998,102.

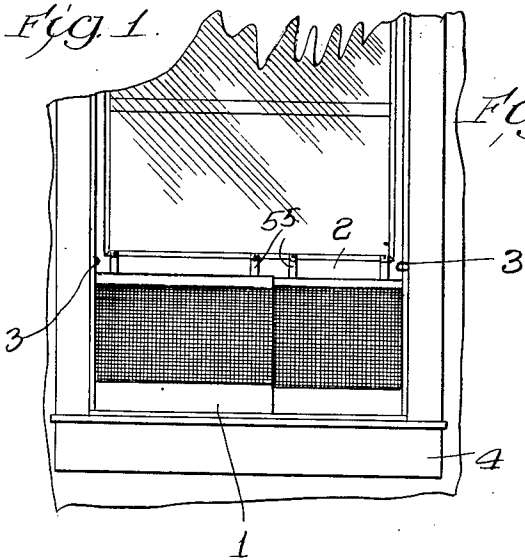

Fig. 2.

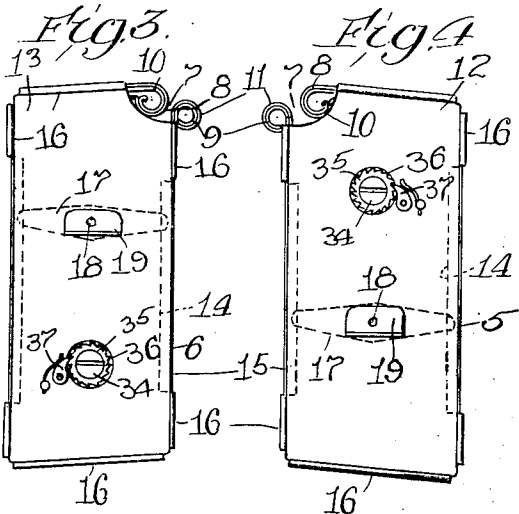
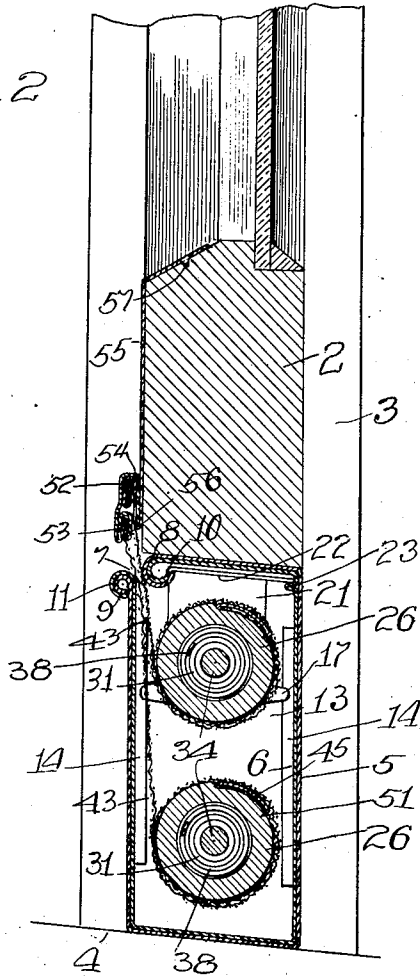
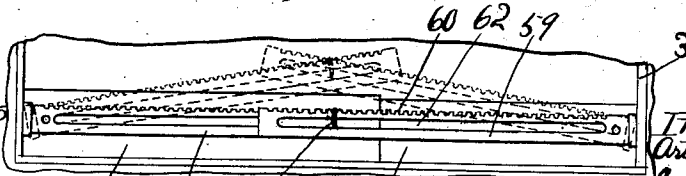

Fig. 20.



Witnesses

C. R. White.

R. A. White.

Inventors

Arthur Ladwig

Joseph Butkus

By M. W. Withersbury Atty.

A. L. LADWIG & J. BUTKUS.
WINDOW SCREEN.

APPLICATION FILED AUG. 16, 1909.

Patented July 18, 1911.

3 SHEETS—SHEET 2.

998,102.

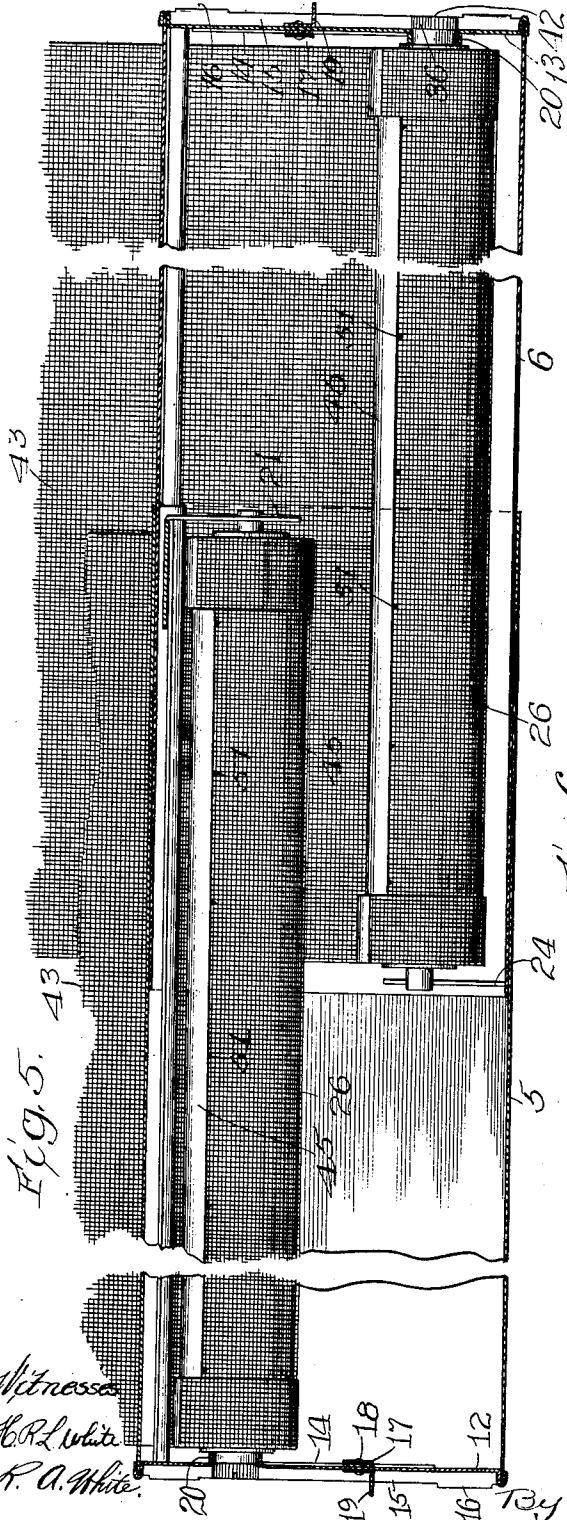

Fig. 5.

Witnesses
H. R. White
R. A. White.

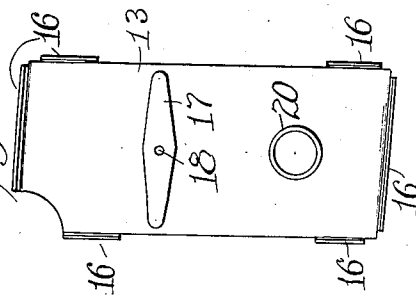

Fig. 6.

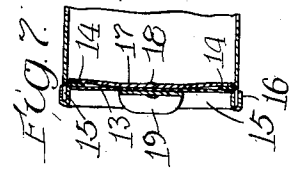

Fig. 7.

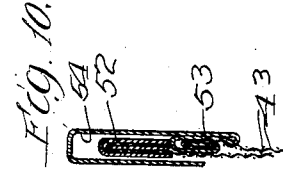

Fig. 10.

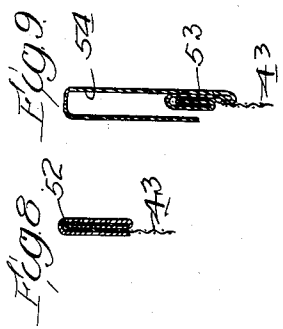

Fig. 9.

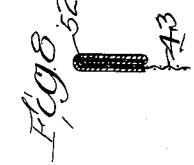

Fig. 8.

Inventors:
Arthur L. Ladwig
Joseph Butkus
By W. W. Withenbury, Atty

A. L. LADWIG & J. BUTKUS.

WINDOW SCREEN.

APPLICATION FILED AUG. 16, 1909.

Patented July 18, 1911.

3 SHEETS—SHEET 3.

998,102.

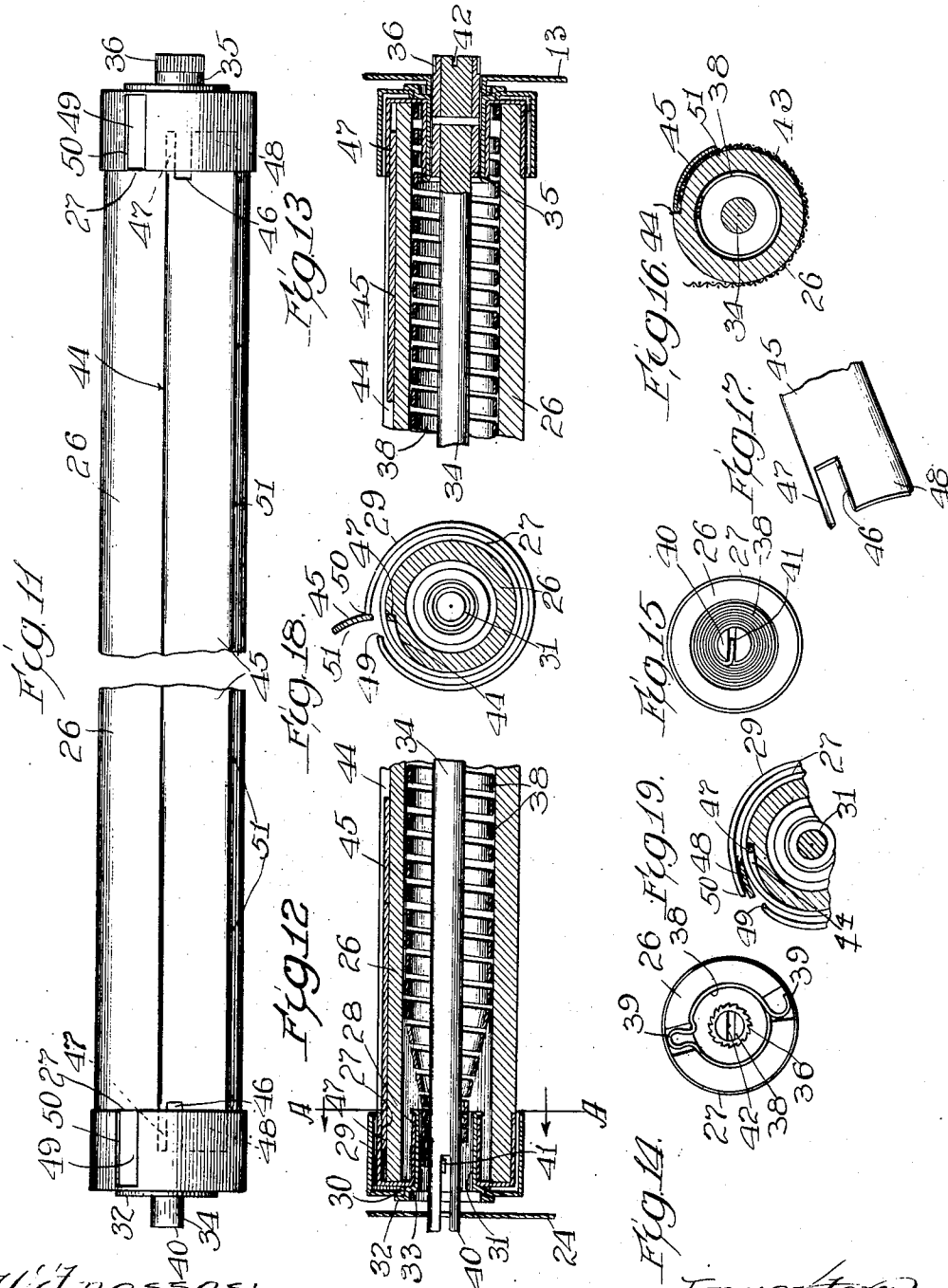

Witnesses:
 C. C. White
 R. A. White.

Inventors:
 Arthur L. Ladwig
 Joseph Butkus

By W. W. Wetherbury
 Atty.

UNITED STATES PATENT OFFICE.

ARTHUR L. LADWIG AND JOSEPH BUTKUS, OF CHICAGO, ILLINOIS.

WINDOW-SCREEN.

998,102.

Specification of Letters Patent. Patented July 18, 1911.

Application filed August 16, 1909. Serial No. 513,019.

To all whom it may concern:

Be it known that we, ARTHUR L. LADWIG and JOSEPH BUTKUS, citizens of the United States, and residing at Chicago, in the county of Cook and State of Illinois, have invented a new and useful Improvement in Window-Screens, of which the following is a complete specification.

The main objects of this invention are to provide a window screen adapted to be automatically operated by the opening or closing movement of the window sash; to provide a window screen in which the screen members, are adapted, when the window is closed, to be contained within a protecting box or casing, and when the window is open to be withdrawn from the casing by the movement of the sash and to completely cover the window opening; to provide an automatically operating window screen adapted to be adjusted to fit varying widths of windows; and to provide a device in which the screen members are so mounted that they may be easily removed from their casings and replaced when desired without the use of skilled labor.

A specific construction embodying said invention is illustrated in the accompanying drawings, in which:

Figure 1 is an elevation of a window, partly open and provided with a screen embodying this invention. Fig. 2 is an enlarged, fragmentary, vertical section of the window and screen. Fig. 3 is an elevation of one end of the screen casing. Fig. 4 is an elevation of the opposite end of the screen casing. Fig. 5 is a fragmentary, longitudinal section of the screen casing, and showing the screen roller and screen members in elevation. Fig. 6 is an inner side elevation of one of the casing heads. Fig. 7 is a fragmentary, horizontal section of the casing, showing the means for locking the casing heads in place. Fig. 8 is a transverse section of one of the telescoping binding strips for the screen members. Fig. 9 is a similar view of the other binding strip. Fig. 10 is a transverse section of the binding strips when connected or nested together. Fig. 11 is a fragmentary, side elevation of the screen roller. Fig. 12 is a fragmentary, longitudinal section of one end of the same. Fig. 13 is a fragmentary, longitudinal section of the other end of the screen roller. Fig. 14 is an end elevation of one end of the

barrel. Fig. 15 is an end elevation of the other end of the barrel. Fig. 16 is a transverse section of the roller, and showing the means for attaching the screen member thereto. Fig. 17 is a fragmentary, perspective view of the clamping plate for the screen member. Fig. 18 is a section taken on line A—A of Fig. 12 and showing the clamping plate open. Fig. 19 is a similar section, partly broken, and showing the clamping plate locked in closed position. Fig. 20 is a fragmentary, side elevation of a window with the casing in place, and showing means for securing the casing in the window opening.

In the construction shown a telescoping casing 1 is provided and is adapted to seat in the window opening beneath the sash 2, and to abut at its ends closely against the window frame 3. The casing is preferably provided with a bottom having the same incline as the window sill 4, and with a top having the same incline as the bottom of the sash 2, so as to form tight joints when the window is closed. Said casing comprises two telescoping sections 5 and 6, which are open along their upper, inner corners as at 7, and the margins of the outer section 5, along said opening, are rolled over to provide a sleeve 8 on one margin and a bead 9 on the other margin, and those on the inner section are rolled to provide a bead 10 adapted to fit in the sleeve 8, and a sleeve 11 adapted to receive the bead 9, as shown more clearly in Figs. 2, 3 and 4.

The outer ends of the sections 5 and 6 are provided respectively with removable heads 12 and 13, which may be secured in place in any preferred manner, but, as shown in Figs. 3, 4 and 7, a portion of the end edges of the side walls of the sections are turned inwardly to provide flanges 14, against which the heads seat. The heads are provided with outwardly turned flanges 15, which are turned back upon themselves to provide hooks 16 adapted to engage over the margins of the casing. In this manner the heads are countersunk within the ends of the casing, as shown more clearly in Figs. 5 and 7. A locking bar 17 is pivoted on the inner side of each head by means of a pivot pin 18, and the outer end of said pin is provided with a handle 19 by means of which the bar may be operated. The ends of said bar are turned inwardly a short distance

from the head and are adapted to engage behind the flanges 14 when the bar is turned transversely of the head, as shown in Figs. 6 and 7.

5 The head 12 is provided near its top with a bearing 20, and the section 5 is provided at its inner end with a bearing bracket 21, having a bearing therein in axial alinement with the bearing 20. In order to support
10 the bracket 21 so that the inner section 6 may pass it, it is suspended from a plate 22 which is formed on the margin of the sleeve 8 and extends across the section and rests on a supporting bead or ledge 23 on
15 the inner side of the section 6, as shown in Fig. 2. The head 13 is also provided with a bearing 20, and at the inner end of the section 6 is a bearing bracket 24 having a bearing therein in axial alinement with the
20 bearing in the head 13.

Mounted in the bearings of each section is a screen roller. Said rollers are parallel with each other, and are disposed one in the upper portion of the casing and the
25 other in the lower portion of the casing, so that as said sections are extended or retracted the rollers move longitudinally with respect to each other.

Each roller comprises a barrel or shell 26,
30 of wood or other suitable material and is provided on each end with an inner ferrule or cap 27, which is rigidly secured thereon and is provided with a bearing sleeve 28 extending axially into the barrel and out of
35 contact therewith. An outer ferrule or cap 29 is rotatively secured on the inner ferrule and is provided in its outer end with an aperture in axial alinement with the sleeve 28 but of larger diameter. A flange 30 extends inwardly about the aperture and abuts
40 against the end of the ferrule 27. A tubular rivet 31 extends through the sleeve 28 and has its inner end swaged over the inner end of the sleeve. The head 32 of said rivet overlaps
45 the outer end of the ferrule 29, and is provided with a shoulder 33 which rests against the end of the ferrule 27.

Extending axially and projecting from the ends of the barrel 26 is a rod 34, which
50 at the end adjacent the outer end of the casing section is provided with a collar 35 which has a bearing in the rivet 31. On the outer end of the collar 35 are ratchet teeth 36, and a spring pressed pawl 37 is
55 pivoted on the outer side of the head and engages said ratchet teeth. A helical spring 38 is contained in the barrel around the rod and has its end adjacent the ratchet engaged to the barrel by forming loops or
60 bends 39 in the spring and countersinking them in recesses in the end of the barrel, as shown in Fig. 14. The other end of the coil is reduced in size and projects into the rivet 31. The rod 34 is notched at its end 40 and
65 the end 41 of the spring is inserted in

the notch so that when the rod is rotated in one direction and the barrel is held stationary the spring is wound up. The end of the rod adjacent the ratchet is provided
70 with a notch 42 or other means for receiving a screw driver or key to rotate the rod.

On each of the rollers and extending the full length thereof is secured a sheet of wire netting or other screen member 43
75 which sheets unroll from the same side of the rollers, or that side adjacent the opening 7 in the casing, and overlap and lie in close contact with each other. For the purpose of detachably securing the screen members to the rollers, each barrel is provided in
80 its outer surface with a longitudinal groove 44, which is eccentric to the periphery of the barrel, and a transversely curved attaching plate 45 is hinged therein. Said plate is provided in each end with a notch 46,
85 which provides hinge arms 47 at the rear of the plate. Said arms lie in the groove beneath the ferrule 27, as shown more clearly in Figs. 12, 13, 18 and 19, and the ends 48
90 of the plate, on the opposite side of the notches from said arms, are adapted to lie on the outer side of the ferrule 27, as shown in Fig. 19. The outer ferrules 29 are each
95 provided with a notch 49, the rear margin 50 of which is slightly raised to permit it to pass over the end 48 when rotated in one direction, and when rotated in the opposite
100 direction the ferrule will pass beneath the end 48, and the forward edge of the plate may then be swung away from the barrel to permit the edge of the screen member to be inserted beneath it. The forward edge
105 of the plate is provided with teeth 51 which engage the member when the plate is again closed or turned against the barrel. When the ferrules 29 are rotated to bring them over the ends 48, the screen member is held securely in place.

The outer edge of one screen member 43 is provided with a binding strip 52, which is
110 folded to clamp the margin of the screen member therein, and the other member 43 is provided with a binding strip 53 which has a channel 54 formed on the top thereof to receive the strip 52, as shown in Figs. 9
115 and 10.

For the purpose of attaching the upper margins of the screen members 43 to the sash, clips 55 are provided, which have hooks
120 56 at their lower ends adapted to be hooked into the folds of the binding strips and permit adjustment longitudinally of the strips. At their upper ends said hooks are provided with teeth 57 which are adapted
125 to engage the lower sash rail.

Any preferred means may be provided for securing the casing in the window opening, but, as shown more clearly in Fig. 20, longitudinally slotted bars 58 and 59 are
130 each pivoted at one end to the side of the

casing, near one end thereof, and said bars overlap at their free ends. The bars are each provided with teeth 60 on their upper edges, and a link 61 is carried in the slots 5 62 in said bars and is adapted to be inserted between the teeth of said bars when the bars are at an angle to each other, as shown in dotted lines. When the bars are forced to parallel relation the link prevents them 10 from moving longitudinally of each other and causes them to move the casing sections into binding contact with the window frame.

The operation of the construction shown is as follows: The screen rollers are placed 15 in their respective casing sections with the screen members wound thereon and having their upper margins projecting through the opening 7. When the sections are put together the rollers lie one above the other 20 and may pass each other when the sections are adjusted to vary the length of the casing. By taking hold of the projecting margins of the screen members the barrels 26 may be held from rotation while the rods 34 are 25 rotated in a direction to partially wind up the springs 38. When the springs have been wound sufficiently to apply the desired tension to the screen members they are held from reverse movement by the ratchet teeth 30 and pawl 36 and 37. The upper margins of the screen members are connected by the telescoping binding strips which may be adjusted to the width of the window opening. By means of the adjustable clips 55 35 the screen members may be secured to the sash. When the sash is raised the roller springs are further wound up by the unrolling action of the screen members. When the sash is lowered the springs cause the 40 barrels to rotate and roll the screen members thereon, thereby retracting them into the casing. When it is desired to replace the screen members by new ones, the casing heads 12 and 13 may be unlocked and removed and the rollers withdrawn. The 45 binding plates 45 are then released by rotating the ferrules 29 in the direction to project the ends of the plate from the notches 46. When it is not desired to use the 50 screens the casing is removed from the window opening and the sections are forced together, so as to occupy a minimum amount of space. The casing may then be stored away with the screen members entirely protected 55 by the casing.

We claim:

1. A window screen comprising a pair of overlapping screen members, a roller for each member, and means supporting said 60 rollers and adapting them to be adjusted longitudinally with respect to each other.

2. A window screen comprising a pair of overlapping screen members adapted to fit closely together, a spring actuated roller for each member, and means supporting said 65

rollers and adapting them to be adjusted longitudinally with respect to each other.

3. A window screen comprising a pair of overlapping screen members adapted to fit closely together, a spring actuated roller 70 for each member, said rollers lying in parallel relation to each other, and telescoping supports for said rollers.

4. A window screen comprising a pair of telescoping casing sections, having alined 75 openings therein, a spring controlled roller in each section, and a screen member mounted on each roller and projecting through said openings.

5. A window screen comprising two tele- 80 scoping casing sections having alined openings therein, a spring controlled roller in each section, means for adjusting the tension of the rollers, a screen member on each roller, said members overlapping each other 85 and projecting through said openings, and telescoping members on the outer margins of said screen members.

6. A window screen comprising a pair of telescoping casing sections open along one 90 corner, a removable head in the outer end of each section, a bearing bracket in the inner end of each section, rollers journaled in said heads and brackets and adapted to be adjusted longitudinally with respect to 95 each other when the sections are adjusted, overlapping screen members, one on each roller and projecting through the opening in the casing sections, and means connecting the upper margins of said screen sections 100 together.

7. A window screen comprising a pair of telescoping casing sections having longitudinally disposed, alined openings therein, 105 a removable head in the outer end of each section, means for locking said heads in place, a roller journaled in each section, said rollers being disposed one above the other, a rod in each roller, a spring connecting each rod with its roller, means for lock- 110 ing the rods to the heads, and a screen member on each roller and projecting through the opening in the sections.

8. The combination with a pair of telescoping casing sections having alined open- 115 ings therein, a removable head in the outer end of each section, a lock for each head, a bearing bracket in each section, a rod in each section, said rod being journaled in the head and bracket in the section, a barrel 120 on each rod, a helical spring connecting each barrel with its rod, means on each head adapted to lock the rods from rotation in one direction, a screen removably secured on each barrel, and telescoping binding 125 strips on the outer margins of each screen.

9. A window screen comprising a pair of telescoping casing sections adapted to be inserted in a window opening, means on said sections adapted to force them into binding 130

contact with the window frame, screen rollers journaled in said sections, and a screen member on each roller, each adapted to overlap the other.

5 10. A window screen comprising a pair of telescoping casing sections, means on said sections adapted to force them apart, screen rollers, one journaled in one section and one in the other section said rollers
10 being parallel but out of alinement with each other, and a screen member on each roller.

11. A window screen comprising two telescoping casing sections, rollers, one
15 journaled in one section and one in the other section that in one section overlapping that in the other, a screen member for each roller, and a clamping plate on each

roller adapted to clamp the screen member to the roller.

12. A window screen comprising a pair
20 of telescoping casing sections, screen rollers, one journaled in one section and one in the other and adapted to be adjusted with respect to each other, a clamping plate hinged
25 on each roller, means for locking the plates in closed position, and a screen member secured beneath each plate.

In testimony whereof we have hereunto subscribed our names in the presence of two
30 witnesses.

ARTHUR L. LADWIG.
JOSEPH BUTKUS.

Witnesses:

W. W. WITHEBURY,
E. R. WALKER.