



(12) **DEMANDE DE BREVET CANADIEN
CANADIAN PATENT APPLICATION**

(13) **A1**

(86) Date de dépôt PCT/PCT Filing Date: 2018/09/18
(87) Date publication PCT/PCT Publication Date: 2019/03/28
(85) Entrée phase nationale/National Entry: 2020/03/19
(86) N° demande PCT/PCT Application No.: CA 2018/051162
(87) N° publication PCT/PCT Publication No.: 2019/056094
(30) Priorité/Priority: 2017/09/19 (US62/560,338)

(51) Cl.Int./Int.Cl. *A44B 19/30* (2006.01),
B65D 33/25 (2006.01), *E05B 65/52* (2006.01)
(71) Demandeur/Applicant:
HIGHCROFT INC., CA
(72) Inventeur/Inventor:
MATCHETT, MICHAEL KENNETH, CA
(74) Agent: EDWARDS, ANTONY C.

(54) Titre : DISPOSITIF ET PROCEDE DE PROTECTION D'UN COMPARTIMENT A FERMETURE A GLISSIERE
(54) Title: DEVICE AND METHOD FOR SECURING A ZIPPERED COMPARTMENT

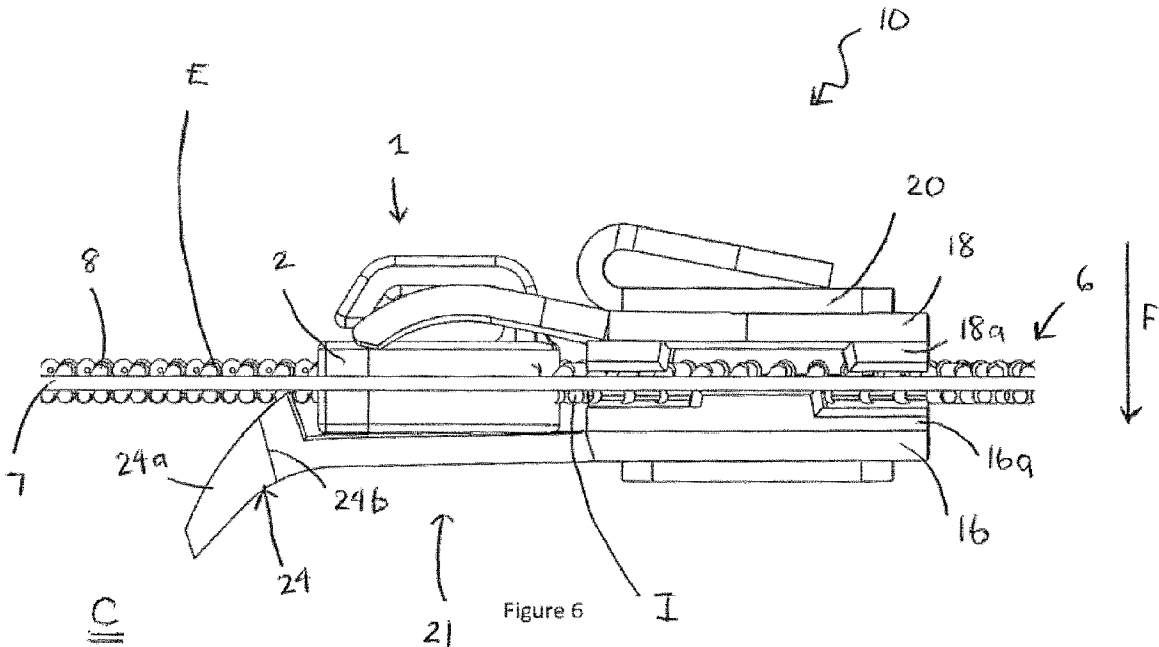

(57) **Abrégé/Abstract:**

A device releasably attachable to a zippered compartment, so as to secure the compartment against unauthorized access is disclosed. The device includes an anchor for mounting the device to the zippered compartment, and a releasable lock for engaging a slider head of the zippered compartment. The anchor includes a clamp, clip, and contact surface so as to engage a portion of the zipper of the zippered compartment. The releasable lock includes a latch. Method of releasably attaching the device to the zippered compartment is also disclosed.

WO 2019/056094 A1 **Declarations under Rule 4.17:**

- *as to applicant's entitlement to apply for and be granted a patent (Rule 4.17(ii))*
- *as to the applicant's entitlement to claim the priority of the earlier application (Rule 4.17(iii))*
- *of inventorship (Rule 4.17(iv))*

Published:

- *with international search report (Art. 21(3))*
- *in black and white; the international application as filed contained color or greyscale and is available for download from PATENTSCOPE*

DEVICE AND METHOD FOR SECURING A ZIPPERED COMPARTMENT**CROSS REFERENCE TO RELATED APPLICATIONS**

This application claims priority from United States Provisional Application No. 62/560,338, filed September 19, 2017, entitled “Device and Method for Securing a Zippered Compartment”, the entirety of which is incorporated herein by reference.

FIELD

The present application relates to a device and method for securing a zippered compartment, and in particular, relates to a device which is releasably attachable to a zippered compartment for securing the compartment against unauthorized access.

BACKGROUND

Children are curious beings who may frequently get into things they shouldn't. For example, various zippered bags or luggage having zippered closures, such as handbags, purses, diaper bags, backpacks, and travel bags, referred to herein collectively as zippered compartments, may contain potentially valuable and delicate goods or hazardous goods. If a zippered compartment does not have a lock or some other type of device for securing the compartment from unauthorized access, small children or other vulnerable persons may open the zippered closure and thereby gain access to the contents which may be hazardous, delicate, valuable, and/or difficult to replace. Similarly, valuables stored within zippered compartments which are unlocked, or otherwise unsecured, may be vulnerable to thieves or pick pockets who may attempt to steal the valuables contained within zippered compartments, such as purses or backpacks, carried by a person in public.

In the prior art of which the Applicant is aware, locking devices for securing zippered closures of compartments may require that the zippered compartment, for example, a purse or bag, be modified in some manner so as to attach the locking device to the zippered compartment. For example, US Patent no. 5,681,115 (the '115 patent) discloses a locking device that can be mounted to a zippered bag using threaded studs inserted through two holes in the zippered bag. The instalment of the device disclosed in the '115 patent would result in permanent modification to the bag or purse, for example. Furthermore, the installation of this device to a zippered compartment may require significant time and effort.

In other prior art of which the Applicant is aware, some locking devices require modification of the zipper slider or the zipper stop, and therefore require that a customized zipper closure arrangement be used during the manufacture of the zippered compartment. For example, in German Patent nos. 10 2010 021 631 B4 (the '631 patent) and 10 2013 106 341 B3 (the '341 patent) each disclose a modified zipper slider including a tongue portion which is received and engaged by the zipper stop. Additionally, German Patent no. 1 211 834 (the '834 patent) discloses a locking device with a modified pull tab on a zipper slider having a pair of slots, and a modified stopper device which has a corresponding pair of slots.

US Patent Publication no. 2014/0060988 A1 (the '988 publication) discloses a locking device that does not require modification to the zippered compartment, zipper slider or zipper stop. The locking device disclosed in the '988 patent is designed to prevent the breach of a closed zipper and the subsequent concealment of the breach, for example on a piece of locked luggage travelling through an airport. The device is secured to the zippered closure by means of a pair of plates held together by fasteners, for example screws, with access to the fasteners being further secured underneath an outer cover, and then the pull tabs of the one or more zipper sliders are secured to the device by means of inserting the shackle of a padlock or other lock through apertures of the pull tabs and apertures of the device. Thus, once the device is installed to the zippered compartment, the zippered compartment is not easily accessible to children or adults, which may include for example adults who are attempting to steal valuables from unattended luggage in an airport.

SUMMARY

In one aspect of the present disclosure, a device is provided for preventing access to a zippered compartment having a zippered closure. In particular, the device is designed so as to prevent or deter access to the zippered compartment by small children or other persons who may have difficulty manipulating the device, while still allowing relatively easy access to the zippered compartment by someone with greater dexterity, such as an adult. Such a device may be particularly useful, for example, in childproofing zippered bags or other zippered compartments, so as to prevent small children from gaining access to the contents held within the bag.

Advantageously, the device may be designed to secure a zippered closure, without having to modify the zippered closure itself or the zippered compartment to which the device is being mounted. Therefore, a person wishing to have a childproof zippered compartment, such as a purse or handbag, is

not required to purchase a specially modified zipper or zippered compartment having a locking feature. Instead, the person may separately acquire the zipper locking device and attach it to an existing bag or purse having a zippered closure. Furthermore, the zipper locking device disclosed herein may be simply removed from the zippered compartment once childproofing is no longer required, thereby leaving the purse, handbag or other zippered compartment in its original, unmodified condition.

In another aspect of the present disclosure, a method of using the zipper locking device to childproof a compartment and/or inhibit access to the compartment, the compartment having a zippered closure, is also provided.

Accordingly, in one aspect a device for securing a compartment having a cavity and zippered closure is provided. The zippered closure includes a zipper track which has a zipper tape and zipper teeth. The zippered closure further includes at least one slider head operatively coupled to the zipper teeth so as to selectively open and close the zippered closure. The device comprises an anchor configured to be releasably mounted on to a portion of the zipper track. The device further includes at least one releasable latch coupled to the anchor. The latch is adapted to receive and releasably lock a slider head of the at least one slider head.

Accordingly, in another aspect a method for releasably securing a compartment having a zippered closure is provided. The zippered closure includes a zipper track which has a zipper tape and zipper teeth. The zippered closure further includes at least one slider head operatively coupled to the zipper teeth so as to selectively open and close the zipper closure. The method comprises the steps of releasably anchoring the device described in the foregoing paragraph to a portion of the zipper track, and engaging the slider head of the at least one slider with the releasable lock of the device.

BRIEF DESCRIPTION OF THE FIGURES

Figure 1 is a side perspective view of the zipper locking device from a first direction;

Figure 2 is a side perspective view of the zipper locking device of Figure 1 with a zipper slider head engaged;

Figure 3 is a top perspective view of the zipper locking device of Figure 1;

Figure 4 is a top perspective view of the zipper locking device of Figure 1 with a zipper slider head engaged;

Figure 5 is a top perspective view of the zipper locking device of Figure 1, anchored to a zippered closure;

Figure 6 is a side perspective view of Figure 5;

Figure 7 is a side perspective view of the zipper locking device of Figure 1 from another direction;

Figure 8 is a bottom perspective view of the zipper locking device of Figure 1.

DETAILED DESCRIPTION

The present disclosure relates to a zipper locking device 10 having an anchor 12 and a releasable lock 21. The device 10 is adapted to secure a zippered closure 4, for example, a bag having a zippered compartment with a cavity C.

The anchor 12 is configured to be releasably mounted onto at least the zippered closure 4. In one embodiment, the anchor 12 includes a clamp 14. The clamp 14 may be a U-shaped clamp, as seen in Figure 1, having an upper portion 18 and a lower portion 16. The clamp 14 includes an opening or gap G, defined between the upper portion 18 and lower portion 16 of the clamp 14, sized so as to snugly receive and frictionally engage a portion of a zippered track 6 of the zippered closure 4, so as to mount the anchor 12 to the zippered closure 4, as best seen in Figure 6. The zipper track 6 includes a zipper tape 7 and zipper teeth 8, as seen in Figures 5 and 6. The anchor 12 may engage the zipper tape 7 and zipper teeth 8, and portions of the zippered compartment 5 adjacent the zipper tape 7, as seen in Figure 5.

In one embodiment, the clamp may include contact surfaces so as to increase the frictional engagement of a portion of the zipper track 6 of the zippered closure 4 by the clamp 14. For example, the clamp may include an upper contact surface 18a and a lower contact surface 16a, both surfaces adjacent to the portion of the zipper track 6 being engaged. The upper 18a and lower contact surfaces 16a may be interlocking, as seen in Figure 1. Although not shown in the drawings, it will be appreciated that the contact surfaces 16a, 18a of the lower and upper portions 16, 18 of clamp 14 may be provided

with roughened surfaces so as to increase the friction between clamp 14 and zippered closure 4 when device 10 is installed on a zippered compartment. In some embodiments, it will be appreciated that a combination of roughened surface and resilient coating may be applied to the contact surfaces of the lower and upper portions 16, 18 of clamp 14 which engage the surfaces of the zippered closure 4 when the anchor 12 is in use. In a preferred embodiment, the contact surface may be manufactured from a rubbery polyethylene.

The anchor 12 may also include a clip 20 such as a spring clip. Clip 20 is adapted to compress clamp 14, so as to increase the engagement between the clamp 14 and the portion of at least the zipper track 6. In one embodiment, the clip 20 may be a U-shaped clip. Clip 20 is slidably mounted on to clamp 14 and is slideable between a locked position and an unlocked position. In the unlocked position, the clamp 14 is not compressed by clip 20, so as to allow a widened gap G. In the locked position, clip 20 is compressing the clamp 14, so as to compress said clamp 14, narrowing gap G, and further securing the device 10 to the zippered compartment. Clip 20 slides between the unlocked and locked positions along a track 28, in direction A and B respectively. For example, without intending to be limiting, as seen in Figure 8, track 28 may include two pins 28a, 28b on the lower portion 16 of the clamp, and two corresponding slots 29 on the clip 20 wherein rotation of clip 20 is limited by pins 28a, 28b. Further, clamp 14 may include at least one protrusion 30, adapted to limit movement of clip 20 in directions A and B, only, and so as to ensure clip 20 remains coupled to clamp 14.

In a preferred embodiment of the present disclosure, clip 20 is spring loaded, adapted to exert a downward force on clamp 14 when in the locked position.

The zipper track 6 includes an exterior surface E and an interior surface I, wherein the exterior surface E and the interior surface I are in opposed facing relation and the interior surface I is adjacent the cavity C of the compartment.

The releasable lock 21 of the zipper locking device 10 is adapted to engage the zipper slider 1 of a zippered closure 4, as shown for example in Figures 2, 4, 5, and 6. In one aspect of the present disclosure, the releasable lock 21 may include a flexible tongue 22, the flexible tongue extending cantilevered from the lower portion 16 of the clamp 14. The flexible tongue 22 includes a distal end 22a, distal from the anchor 12 of the device 10, the distal end 22a including a latch 24. In a preferred embodiment of the present disclosure, the latch 24 includes a smooth outer ramp portion 24a and an upwardly extending, vertical wall 24b opposite the smooth ramp portion 24a, as shown in Figure 1. The

releasable lock 21 extends along the interior surface I of the zippered track 6, below the exterior surface E, when the anchor is mounted to the zippered closure 4. In other words, the releasable lock 21 extends within cavity C of the zippered compartment.

The device 10 may further include at least one release arm 26, the release arm 26 extending cantilevered from the upper portion 18 of the clamp and in opposed facing relation to the flexible tongue 22. The release arm 26 extends along the exterior surface E of the zippered track 6, so as to abut at least the zipper tape. In some cases, the release arm 26 may abut portions of the zippered compartment 5 adjacent the zipper tape 7. The release arm 26 exerts a downward pressure on zipper tape 7 and/or fabric 5. When slider head 2 is engaged by releasable lock 21, the downward pressure exerted on the zipper tape 7 and/or fabric 5 assists in maintaining said engagement.

In use, the zipper locking device 10 may be installed on a zippered compartment by, firstly, anchoring the device 10 to the zippered closure 4, and then engaging the slider 1 of the zippered closure with the releasable lock 21. To install the anchor 12 of the device 10 illustrated in Figures 1-8, clip 20 is configured to the unlocked position by sliding the clip 20 along track 28 in direction A, as seen in Figure 3. Then a portion of the zipper tape 7, zipper teeth 8 and/or portions of the zippered compartment adjacent the zipper tape 9 is inserted into the widened gap G of the clamp 14, whereby the lower portion 16 of clamp 14 is adjacent the cavity of the zippered compartment and the upper portion 18 is protruding outwardly of, and positioned proximate to, the zippered closure 4. Then, clip 20 may be pivoted into its locked position along track 28 in direction B, so that the downward force of clip 20 compresses clamp 14 and urges lower portion 16 towards upper plate 18 so as to narrow gap G and reduce the distance between the upper and lower portions 16, 18. As the lower portion 16 is urged towards the upper portion 18, the zipper tape 7 (shown in Figure 6) and/or adjacent portions of the zippered closure 5 become compressed between lower portion 16 and upper portion 18 of clamp 14, thereby anchoring the device 10 in place on the zippered closure 4. Once the anchor 12 of device 10 is installed on the zippered closure 4, the device may be securely held in its position along the zipper tape 7 and/or zipper teeth 8 of the zippered closure 4. Preferably, the device 10, once anchored, may not slide along the zippered closure 4 when a force is applied to the device. The device is then ready for releasably locking one or more sliders 1 of the zippered closure 4. Preferably, the device 10 may be installed on the zippered closure 4 at a position which is substantially adjacent the top stop 9 of the zippered closure, which is typically positioned at the end of the zipper tape 7 where the zipper slider 1 is positioned when the zippered closure 4 is closed, as may be seen for example in Figure 5.

To lock the zippered closure, the releasable lock 21 releasably engages with slider head 2 of the slider 1 of the zippered closure 4. In use, the slider 1 is moved along the zipper tape 7 in direction D towards the slider guide 22 of the zipper locking device 10. As the slider 1 approaches the releasable lock 21, the front edge 3 of the slider 1 encounters the smooth ramp portion 24a of latch 24, thereby allowing the slider head 2 to travel over the latch 24. As slider 1 continues to travel in direction D along the flexible tongue 22, the head 2 of the slider is fully engaged when the rear edge 5 of the slider 1 passes over latch 24 of flexible tongue 22. Once slider head 2 has passed over latch 24, flexible tongue 22 urges latch 24 upwardly behind head 2 to form a stop. In a preferred embodiment of the present disclosure, the distal end 22a of the releasable lock 21 includes a wide surface so as to abut the interior surface 1 of the zipper tape 7 and prevent tongue 22 from flicking upwards upon making contact with slider head 2.

Thus, once the slider 1 is fully received by the releasable lock 21, the slider 1 cannot easily be removed from the lock 21 by moving the slider in direction E, because the rear edge 5 of the slider abuts against the vertical wall portion 24b of the latch 24. Therefore, in order to enable removal of the slider head 2 from releasable lock 21, a downward force must be exerted on the release arm 26. A downward force exerted on the upper portion 18 of the clamp 14 will also be exerted on the release arm 26. Imparting a force pushing downward on the release arm 26, causes the flexible tongue 22 to deflect downwardly, thereby moving latch 24 downwardly and away from the rear edge 5 of the slider 1. Once the latch 24 is no longer hooked behind the rear edge 5 of the slider, the slider 1 may then be disengaged from the releasable lock 21 by sliding the slider in direction E away from lock 21.

Advantageously, this slider release operation requires some level of dexterity, for example by typically requiring depression of the release arm 26 with one hand while using the other hand to slide the slider 1 in direction E. While such an operation may be easily performed by a person with sufficient dexterity and coordination, such as a typical adult, most small children would not have sufficient strength in their hands or the coordination and dexterity required to perform this operation. As such, this device may prevent a small child from accessing the zippered compartment, while not hindering an adult from doing so.

It will be appreciated by a person skilled in the art that other variations of the anchor 12 and releasable locking mechanisms of the device disclosed herein, which have the respective functions of anchoring the device to the zippered closure 4 of the zippered compartment and releasably engaging

the head 2 of the slider portion of a zipper, are intended to be included within the scope of the present disclosure and that the invention disclosed herein is not intended to be limited to the specific embodiments disclosed.

It will further be appreciated that different configurations of the zipper locking device may be used so as to effectively lock zippered compartments having different configurations of zippered closures. For example, it may be the case that a zippered compartment includes a zippered closure having two sliders which are brought so as to be adjacent to one another when the zippered closure is in a closed position. For such a zipper configuration, the zipper locking device disclosed herein may be modified so as to include an anchor, such as anchor 12, in the middle of the device flanked by releasable locks 21 on each side of the anchor. In such a configuration, use of the device may include anchoring the device to a portion of the zippered closure which is somewhere in-between the two ends of the zippered closure 4, and then engaging each of the two zipper sliders 1 with each of the two respective releasable locks 21 on the device. Other possible variations of the zipper locking device are intended to be included in the scope of the present disclosure.

In a preferred embodiment of the present disclosure, the device 10 may be manufactured of polyethylene.

WHAT IS CLAIMED IS:

1. A device for securing a compartment having a cavity and zippered closure, the zippered closure including a zipper track, the zipper track having a zipper tape and zipper teeth, and at least one slider head operatively coupled to the zipper teeth so as to selectively open and close the zippered closure, the device comprising:

an anchor configured to be releasably mounted on to a portion of the zipper track,

at least one releasable latch coupled to the anchor, and adapted to receive and releasably lock a slider head of the at least one slider head.
2. The device of claim 1, wherein the anchor includes a clamp, defining a gap therein, wherein the gap is sized to snugly receive therein the portion of the zipper track so as to frictionally engage the anchor with the portion of the zipper track.
3. The device of claim 2 wherein the clamp includes a lower portion and an upper portion.
4. The device of claim 3, wherein the zipper track includes an exterior surface, exterior relative to the cavity of the compartment, and an opposite interior surface adjacent the cavity of the compartment, the anchor further including at least one flexible release arm extending cantilevered from the upper portion of the clamp, so as to extend along the exterior surface of the zipper track when the anchor is mounted to the zipper track, and so as to cooperate with the latch to release the latch upon depression of the flexible arm.
5. The device of claim 4 wherein the at least one releasable lock includes a flexible tongue extending cantilevered from the lower portion of the clamp, the tongue extending along the inner surface of the zipper track when the anchor is mounted to the zipper track.
6. The device of claim 5 wherein the flexible tongue includes a distal end distal from the anchor and latch wherein the coupled to the distal end, the latch comprising a ramp, distal from the anchor, so as to guide the slider head past said latch as the slider head translates over the zipper track and towards the anchor.
7. The device of claim 6 wherein the latch further comprises a lip, the lip adapted to engage a rearward edge of the slider head so as to said releasably lock the slider head to the anchor.

8. The device of claim 6 wherein the release arm is in opposed facing relation to the flexible tongue and the zipper track interleaved therebetween, such that said depressing of the release arm engages the tongue through the zipper tape so as to release the latch from the slider head.
9. The device of claim 6 wherein the anchor further comprises a clip, slidably mounted on the clamp, the clip slideable between a locked position, so as to compress the clamp, and an unlocked position, so as to decompress the clamp.
10. The device of claim 9 wherein the clamp includes a slide track along which the clip slides relative to the anchor.
11. The device of claim 9 wherein the clamp includes at least one protrusion slidably engaged in the slide track so as to slidably secure the clip to the anchor.
12. The device of claim 9 wherein the clip is a spring clip.
13. The device of claim 12 wherein each portion of the upper and lower portions of the clamp includes a frictional contact surface, the contact surface being adjacent to the portion of the zipper track when the anchor is mounted to the zipper track, wherein each of the contact surfaces is textured so as to frictionally engage the portion of the zipper track in the gap of the clamp when the anchor is mounted to the zipper track.
14. The device of claim 9 wherein the contact surface is polyethylene.
15. The device of claim 1 wherein the at least one releasable lock includes a first and second releasable latch, the first releasable lock extending from a first end of the device and the second releasable lock extending from a second end of the device, the second end distal from the first end.
16. A method for releasably securing a compartment having a zippered closure, the zippered closure including a zipper track, the zipper track having a zipper tape and zipper teeth, and at least one slider head operatively coupled to the zipper teeth so as to selectively open and close the zipper closure, the method comprising the steps of:

releasably anchoring the device of claim 13 to a portion of the zipper track,

engaging the slider head of the at least one slider with the releasable lock of the device.
17. The method of claim 17, wherein the anchoring step further comprises the steps of:

sliding the clip along the track, so as to position the clip in the unlocked position,

mounting the clamp to the portion of the zipper track so that the tongue extends along the interior surface and the releasable arm extends along the exterior surface of the zipper track,

sliding the clip along the track, so as to position the clip into the locked position.

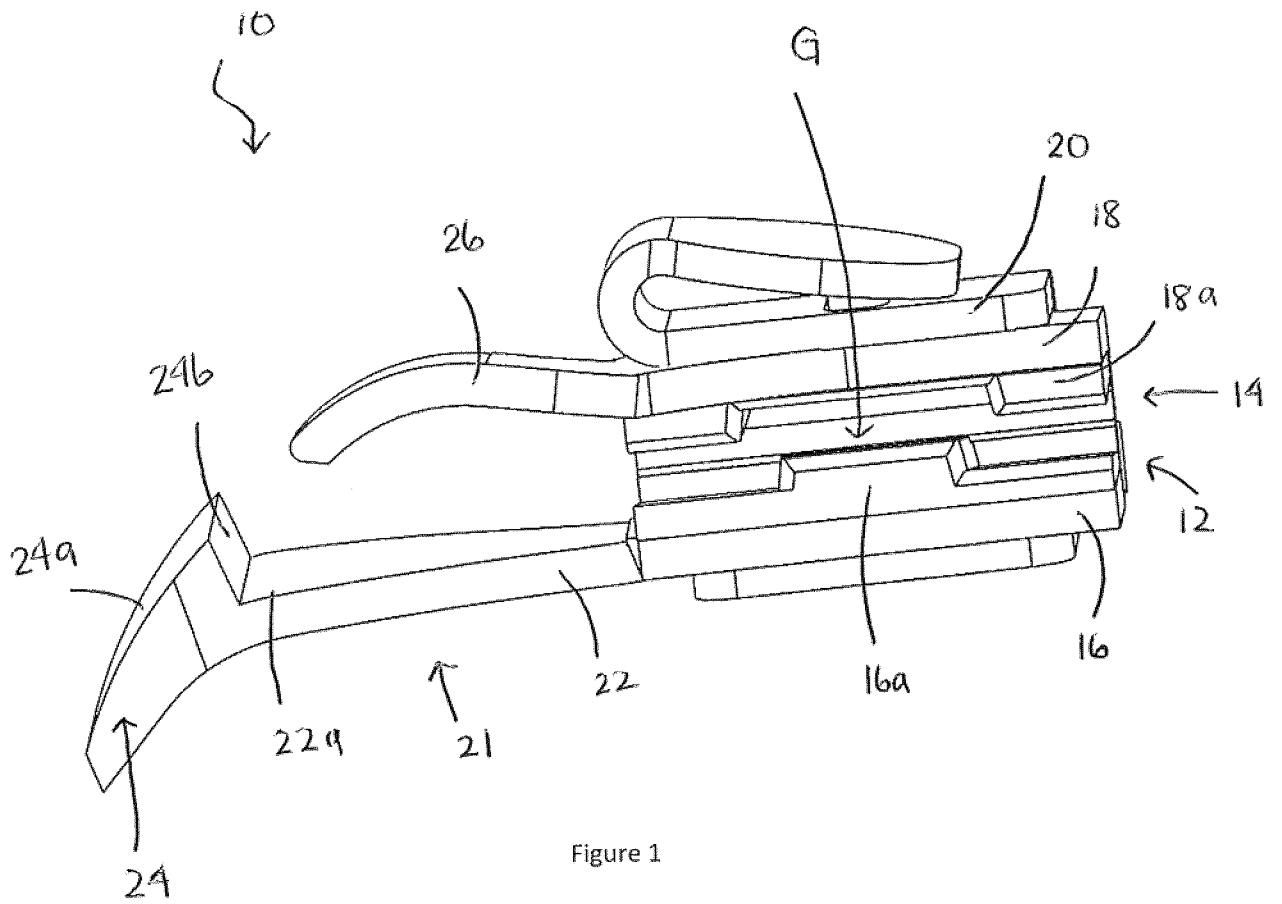

Figure 1

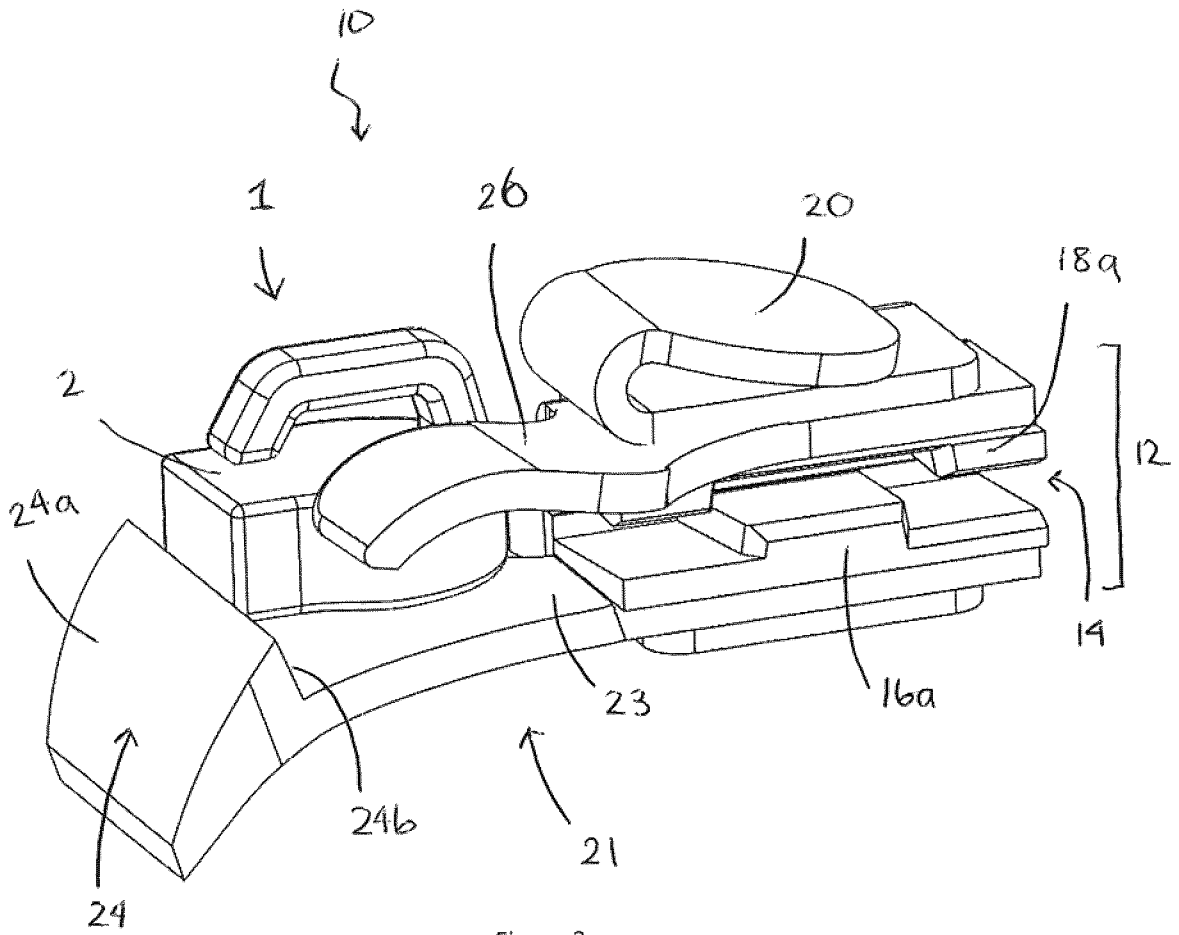

Figure 2

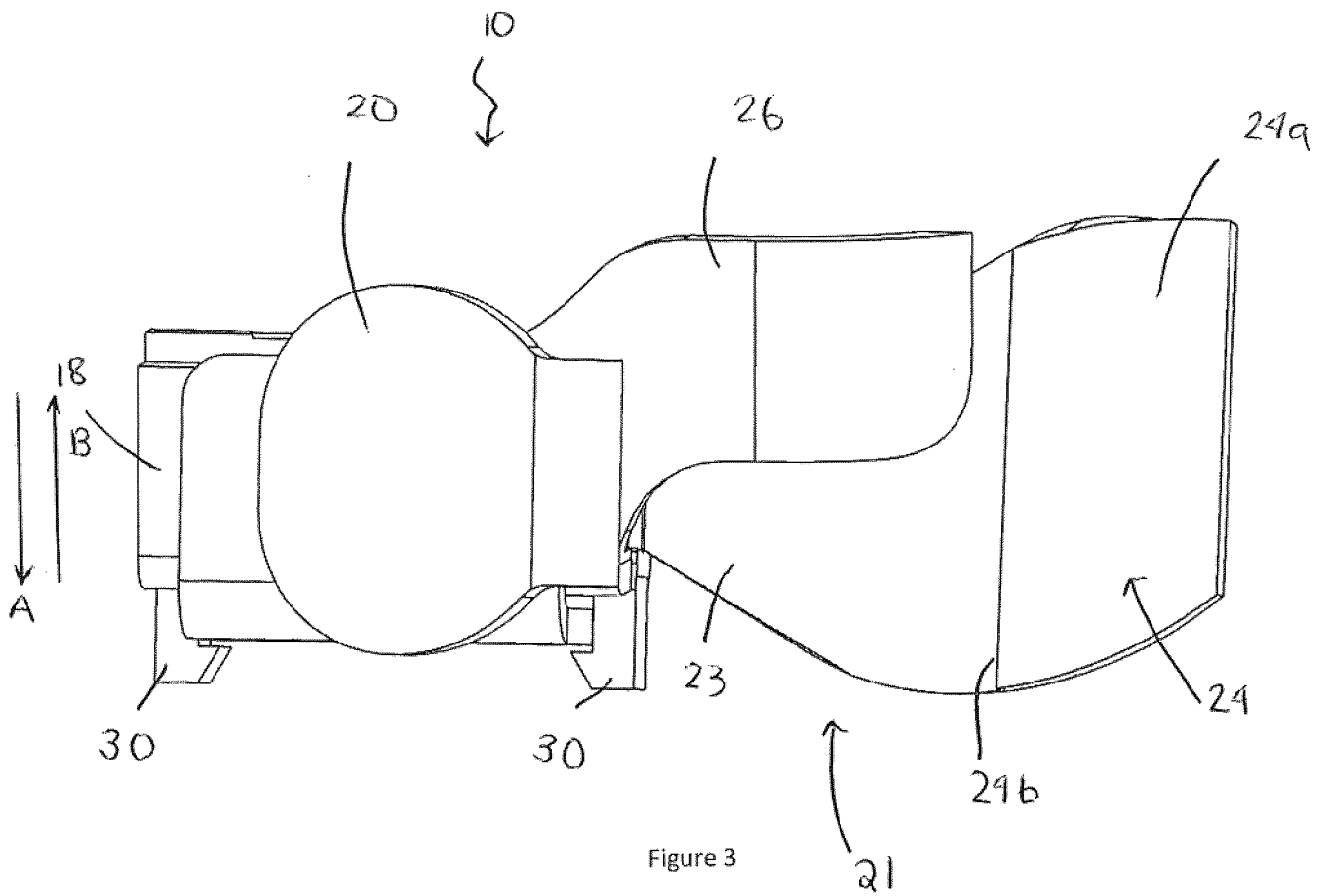

Figure 3

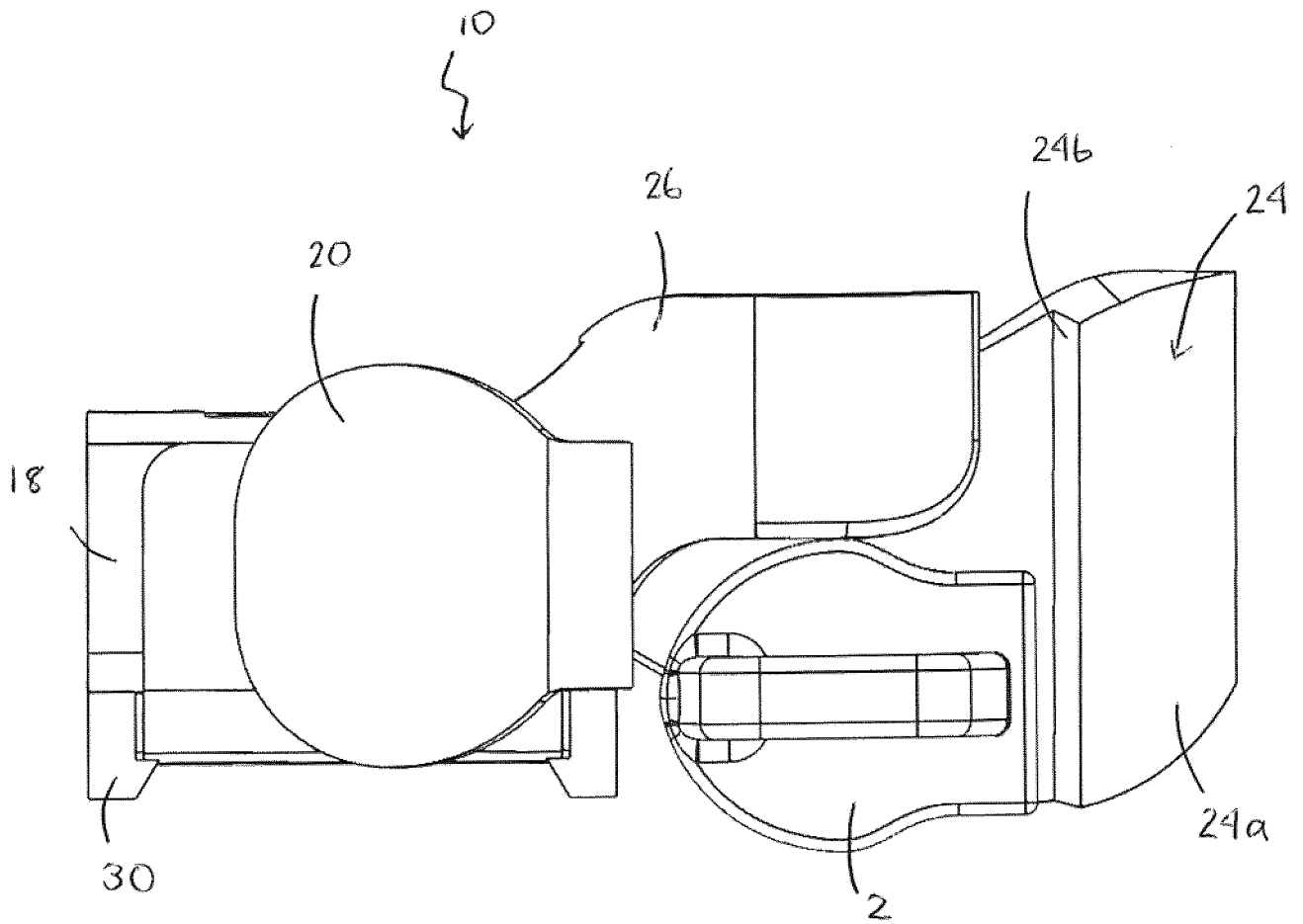

Figure 4

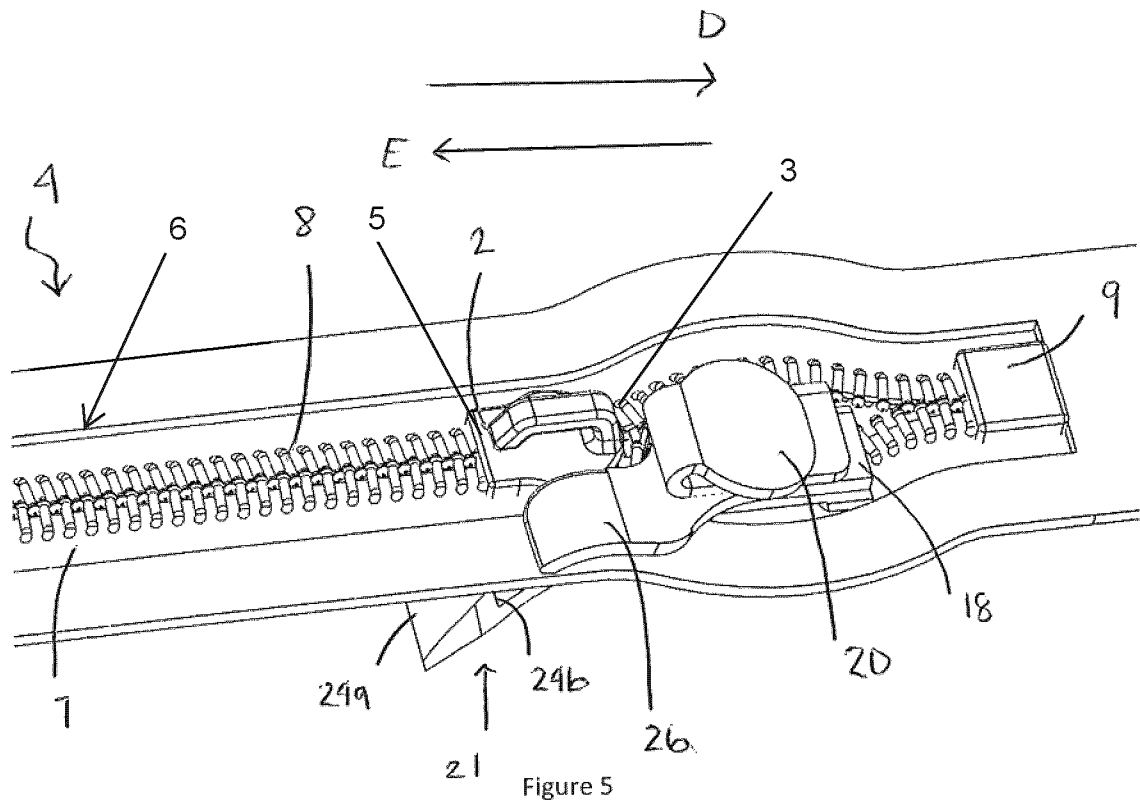
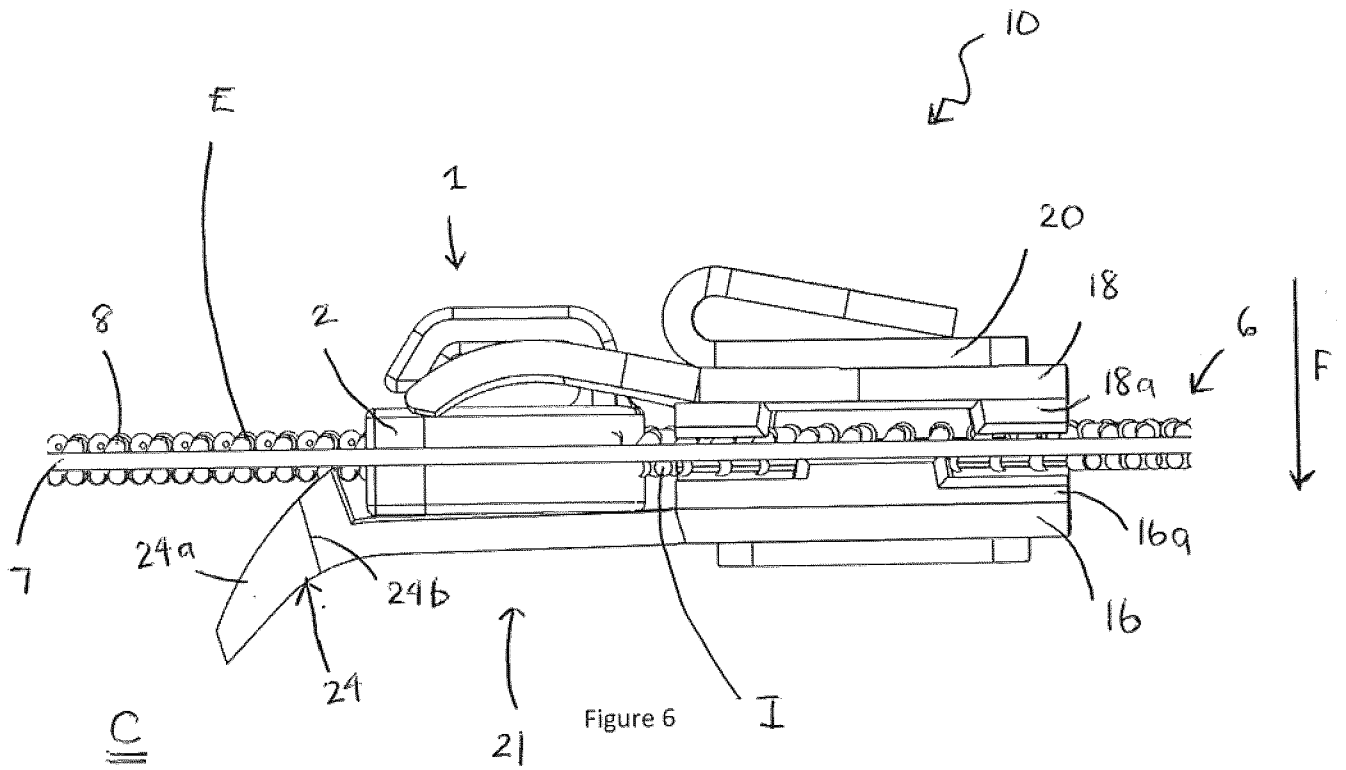

Figure 5



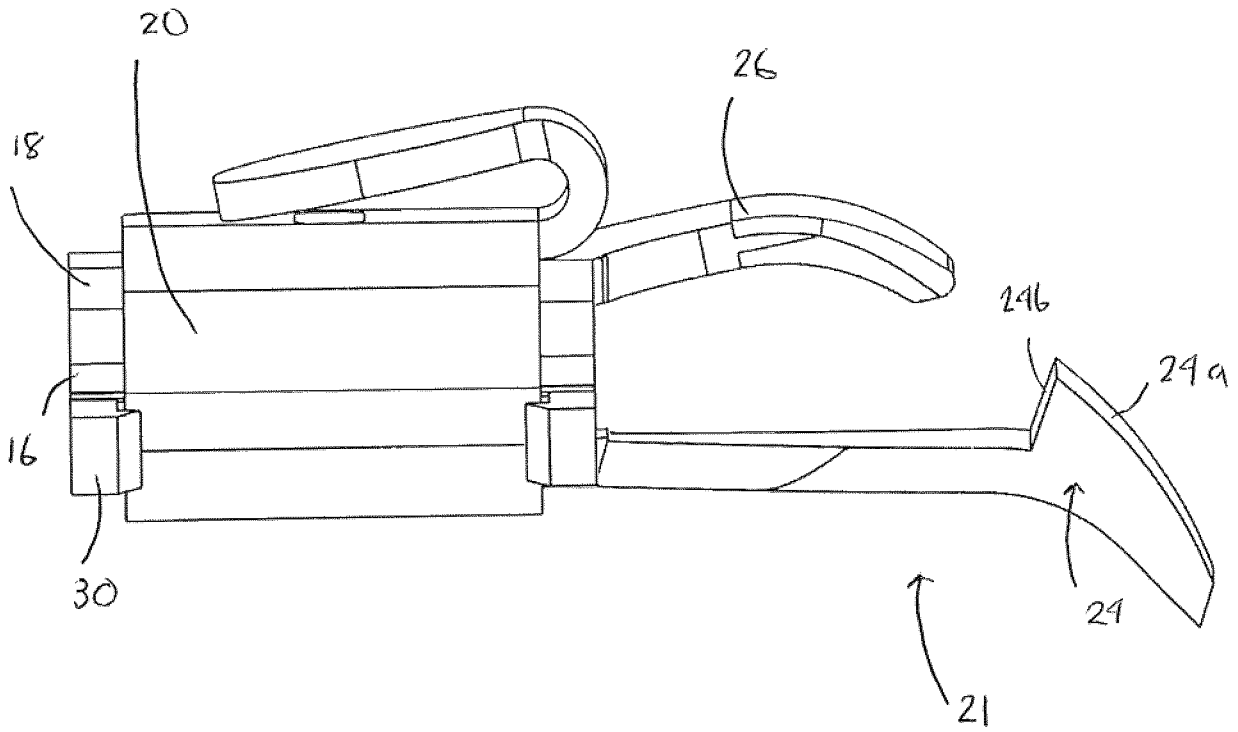

Figure 7

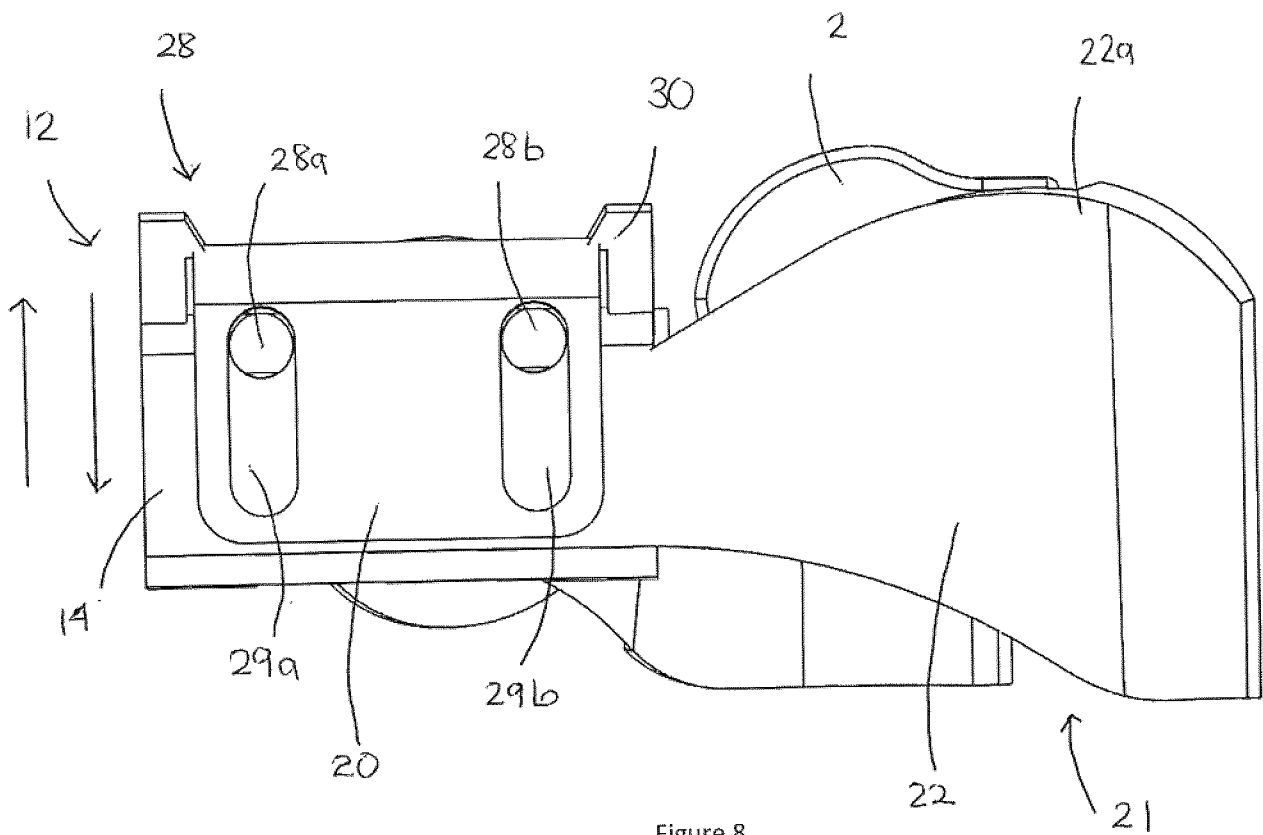

Figure 8

