

(19)



(11)

**EP 1 659 257 B1**

(12)

**EUROPEAN PATENT SPECIFICATION**

(45) Date of publication and mention of the grant of the patent:  
**27.01.2010 Bulletin 2010/04**

(51) Int Cl.:  
**E21B 17/01 (2006.01)**

(21) Application number: **04030599.7**

(22) Date of filing: **23.12.2004**

**(54) Offshore exploration and production system having an adjustable buoyancy chamber**

Offshore Forschungs- und produktionssystem mit verstellbaren Auftriebskammer

Système d'exploration et de production de pétrole en mer ayant une chambre de flottaison réglable

(84) Designated Contracting States:  
**AT BE BG CH CY CZ DE DK EE ES FI FR GB GR HU IE IS IT LI LT LU MC NL PL PT RO SE SI SK TR**

- **Maidla, Eric E.**  
**Sugar Land, TX 77479 (US)**
- **King, Charles H.**  
**Austin, TX 78734 (US)**

(30) Priority: **22.11.2004 US 994799**

(43) Date of publication of application:  
**24.05.2006 Bulletin 2006/21**

(74) Representative: **Hess, Peter K. G.**  
**Patent- und Rechtsanwälte**  
**Bardehle . Pagenberg . Dost .**  
**Altenburg . Geissler**  
**Postfach 86 06 20**  
**81633 München (DE)**

(73) Proprietor: **Anadarko Petroleum Corporation**  
**The Woodlands, TX 77380 (US)**

(72) Inventors:  
• **Millheim, Keith Dr.**  
**The Woodlands, TX77381 (US)**

(56) References cited:  
**EP-A- 0 802 302 GB-A- 2 337 068**  
**US-A- 3 280 908 US-A- 4 448 266**

**EP 1 659 257 B1**

Note: Within nine months of the publication of the mention of the grant of the European patent in the European Patent Bulletin, any person may give notice to the European Patent Office of opposition to that patent, in accordance with the Implementing Regulations. Notice of opposition shall not be deemed to have been filed until the opposition fee has been paid. (Art. 99(1) European Patent Convention).

**Description****FIELD OF INVENTION**

**[0001]** The present invention relates generally to oil and gas exploration and production, and in a specific, non-limiting embodiment, to a system and method of installing and maintaining an offshore exploration and production system having an adjustable buoyancy chamber.

**BACKGROUND OF INVENTION**

**[0002]** Innumerable systems and methods have been employed in efforts to find and recover hydrocarbon reserves around the world. At first, such efforts were limited to land operations involving simple but effective drilling methods that satisfactorily recovered reserves from large, productive fields. As the number of known producing fields dwindled, however, it became necessary to search in ever more remote locales, and to move offshore, in the search for new resources. Eventually, sophisticated drilling systems and advanced signal processing techniques enabled oil and gas companies to search virtually anywhere in the world for recoverable hydrocarbons.

**[0003]** Initially, deepwater exploration and production efforts consisted of expensive, large scale drilling operations supported by tanker storage and transportation systems, due primarily to the fact that most offshore drilling sites are associated with difficult and hazardous sea conditions, and thus large scale operations provided the most stable and cost-effective manner in which to search for and recover hydrocarbon reserves. A major drawback to the large-scale paradigm, however, is that explorers and producers have little financial incentive to work smaller reserves, since potential financial recovery is generally offset by the lengthy delay between exploration and production (approximately 3 to 7 years) and the large capital investment required for conventional platforms and related drilling and production equipment. Moreover, complex regulatory controls and industry-wide risk aversion have led to standardization, leaving operators with few opportunities to significantly alter the prevailing paradigm. As a result, offshore drilling operations have traditionally been burdened with long delays between investment and profit, excessive cost overruns, and slow, inflexible recovery strategies dictated by the operational environment.

**[0004]** More recently, deepwater sites have been found in which much of the danger and instability present in such operations is avoided. For example, off the coast of West Africa, Indonesia and Brazil, potential drilling sites have been identified where surrounding seas and weather conditions are relatively mild and calm in comparison to other, more volatile sites such as the Gulf of Mexico and the North Sea. These recently discovered sites tend to have favourable producing characteristics, yield positive exploration success rates, and admit to pro-

duction using simple drilling techniques similar to those employed in dry land or near-shore operations.

**[0005]** However, since lognormal distributions of recoverable reserves tend to be spread over a large number of small fields, each of which yield less than would normally be required in order to justify the expense of a conventional large-scale operation, these regions have to date been underexplored and underproduced relative to its potential. Consequently, many potentially productive smaller fields have already been discovered, but remain undeveloped due to economic considerations. In response, explorers and producers have adapted their technologies in an attempt to achieve greater profitability by downsizing the scale of operations and otherwise reducing expense, so that recovery from smaller fields makes more financial sense, and the delay between investment and profitability is reduced.

**[0006]** For example, in published Patent Application No. US 2001/0047869 A1 and a number of related pending applications and patents issued to Hopper *et al.*, various methods of drilling deepwater wells are provided in which adjustments to the drilling system can be made so as to ensure a better recovery rate than would otherwise be possible with traditional fixed-well technologies. However, the Hopper system cannot be adjusted during completion, testing and production of the well, and is especially ineffective in instances where the well bore starts at a mud line in a vertical position. The Hopper system also fails to support a variety of different surface loads, and is therefore self-limiting with respect to the flexibility drillers desire during actual operations.

**[0007]** In U.S. Letters Patent No. 4,223,737 to O'Reilly, a method is disclosed in which the problems associated with traditional, vertically oriented operations are addressed. The method of O'Reilly involves laying out a number of interconnected, horizontally disposed pipes in a string just above the sea floor (along with a blow out preventer and other necessary equipment), and then using a drive or a remote operated vehicle to force the string horizontally into the drilling medium. The O'Reilly system, however, is inflexible in that it fails to admit to practice while the well is being completed and tested. Moreover, the method utterly fails to contemplate functionality during production and workover operations. In short, the O'Reilly reference is helpful only during the initial stages of drilling a well, and would therefore not be looked to as a systemic solution for establishing and maintaining a deepwater exploration and production operation.

**[0008]** Other offshore operators have attempted to solve the problems associated with deepwater drilling by effectively "raising the floor" of an underwater well by disposing a submerged wellhead above a self-contained, rigid framework of pipe casing that is tensioned by means of a gas filled, buoyant chamber. For example, as seen in prior U.S. Letters Patent No. 6,196,322 B1 to Magnusen, the Atlantis Deepwater Technology Holding Group has developed an artificial buoyant seabed (ABS) system, which is essentially a gas filled buoyancy chamber

deployed in conjunction with one or more segments of pipe casing disposed at a depth of between 182 and 274 m (600 and 900 feet) beneath the surface of a body of water. After the ABS wellhead is fitted with a blow out preventer during drilling, or with a production tree during production, buoyancy and tension are imparted by the ABS to a lower connecting member and all internal casings. The BOP and riser (during drilling) and production tree (during production), are supported by the lifting force of the buoyancy chamber. Offset of the wellhead is reasonably controlled by means of vertical tension resulting from the buoyancy of the ABS.

**[0009]** The Atlantis ABS system is deficient, however, in several practical respects. For example, the '322 Magnussen patent specifically limits deployment of the buoyancy chamber to environments where the influence of surface waves is effectively negligible, *i.e.*, at a depth of more than about 152 m (500 feet) beneath the surface. Those of ordinary skill in the art will appreciate that deployment at such depths is an expensive and relatively risk-laden solution, given that installation and maintenance can only be carried out by deep sea divers or remotely operated vehicles, and the fact that a relatively extensive transport system must still be installed between the top of the buoyancy chamber and the bottom of an associated recovery vessel in order to initiate production from the well.

**[0010]** The Magnussen system also fails to contemplate multiple anchoring systems, even in instances where problematic drilling environments are likely to be encountered. Moreover, the system lacks any control means for controlling adjustment of either vertical tension or wellhead depth during production and workover operations, and expressly teaches away from the use of lateral stabilizers that could enable the wellhead to be deployed in shallower waters subject to stronger tidal and wave forces.

**[0011]** US 4448266 A discloses an offshore exploration and production system and a method of installing and maintaining an offshore exploration and production system corresponding to the preambles of independent claims 1 and 10.

**[0012]** Thus, there is plainly a widespread need for a system and method of disposing an offshore wellhead in a manner such that drillers can adjust both the depth of a wellhead and the vertical tension applied to associated pipe casing throughout the duration of exploration and production operations. There is also a need for an adjustable buoyancy chamber system capable of maintaining approximately constant vertical tension on an associated drilling or production string, and adjusting either the height of a wellhead at any time during exploration and production by releasing additional lengths of tension line from a buoyancy chamber height adjustment member. There is also a need for an offshore exploration and production system that flexibly admits to use in connection with both deepwater and shallow target horizons, without necessarily being configured to conform to any

particular operational depth.

## **SUMMARY OF INVENTION**

5 **[0013]** The above mentioned needs are satisfied by a system and method of establishing an offshore exploration and production system according to independent claims 1 and 10. The invention provides such system and method, in which a well casing is disposed in communication with an adjustable buoyancy chamber and a well hole bored into the floor of a body of water. A lower connecting member joins the well casing and the chamber, and an upper connecting member joins the adjustable buoyancy chamber and a well terminal member. The chamber's adjustable buoyancy enables an operator to vary the height or depth of the well terminal member and to vary the vertical tension imparted to drilling and production strings throughout exploration and production operations. Also provided is a system and method of adjusting the height or depth of a wellhead while associated vertical and lateral forces remain approximately constant. A variety of well isolation members, lateral stabilizers and anchoring means, as well as several methods of practicing the invention, are also disclosed.

## **BRIEF DESCRIPTION OF THE DRAWINGS**

### **[0014]**

30 Fig. 1 is a side view of an offshore exploration and production system in which an adjustable buoyancy chamber is employed to adjust the height or depth of an associated well terminal member.

35 Fig. 2A and 2B are side views of an offshore exploration and production system, in which lateral and vertical forces on an adjustable buoyancy chamber are held approximately constant while the height of an associated well terminal member is adjusted by releasing additional lengths of tension line.

## **DETAILED DESCRIPTION OF THE INVENTION**

40 **[0015]** Referring now to the specific, non-limiting embodiment of the invention depicted in Figure 1, an offshore exploration and production system is provided, comprising a well casing 2 installed in communication with a submerged well 1 and an adjustable buoyancy chamber 9, wherein a lower connecting member 5 is disposed between the well casing and the adjustable buoyancy chamber. In a presently preferred embodiment, the well 1 is accessed from above by means of a well hole 3 that has been bored into an associated sea floor surface. In a typical embodiment, a well casing 2 is set into the hole in a firm and secure manner, and then cemented into place using known downhole technology. In other embodiments, a well casing is securely set into the well hole 3, and a fluid transport member, such as a smaller-diameter pipe or pipe casing, is inserted into well casing

2. Once a desired fit has been achieved, the outer surface of the fluid transport member is cemented or set with a packer to the inner surface of the well casing. Those of ordinary skill in the art will appreciate that while the embodiment described above refers to but a single well, the offshore exploration and production system disclosed herein can be readily adapted to simultaneously work multiple neighboring wells without departing from the scope of the invention.

According to a one embodiment, a well isolation member 4 is disposed between well casing 2 and a lower connecting member 5. In some embodiments, well isolation member 4 comprises one or more ball valves, which, if lower connecting member 5 is removed, can be closed so that the well is effectively shut in. In further embodiments, well isolation member 4 comprises a blowout preventer or a shear ram that can be maintained in either an open or closed position in order to provide access to, or to instead shut in, the contents of well 1.

**[0016]** In other embodiments, lower connecting member 5 further comprises one or more receiving members disposed to receive an attachment member disposed on well isolation member 4. In an alternative embodiment, lower connecting member 5 comprises an attachment member for attaching said lower connecting member 5 to a receiving member disposed on well isolation member 4. Methods and means of securely fastening lower connecting member 5 to well isolation member 4 are known to those of ordinary skill in the art, and may comprise one or more of a wide variety of fastening techniques, *e.g.*, hydraulic couplers, various nut and bolt assemblies, welded joints, pressure fittings (either with or without gaskets), swaging, *etc.*, without departing from the scope or spirit of the present invention.

**[0017]** Likewise, lower connecting member 5 may comprise any known connecting means appropriate for the specific application contemplated by operators. For example, in various embodiments, lower connecting member 5 comprises one or more of segments of riser, riser pipe, and/or pipe casing. In some embodiments, lower connecting member 5 comprises a concentric arrangement, for example, a fluid transport member having a smaller outer diameter than the inner diameter of a pipe casing in which the fluid transport member is housed.

**[0018]** In further embodiments, lower connecting member 5 is disposed in communication with one or more lateral stabilizers 6, which, when deployed in conjunction a plurality of tension lines 7, effectively controls horizontal offset of the system. By utilizing the buoyant forces of adjustable buoyancy chamber 9, lower connecting member 5 is drawn taut and held in a stable position.

**[0019]** In an alternative embodiment, one or more stabilizers 6 control horizontal offset of lower connecting member 5, and the height or depth of an associated well terminal member 14 is adjusted by varying the length of upper connecting member 12. In some embodiments, the vertical tension of lower connecting member 5 is held approximately constant while the height or depth of well

terminal member 14 is adjusted. In further embodiments, the height or depth of well terminal member 14 is held approximately constant, while the vertical tension imparted by adjustable buoyancy chamber 9 on lower connecting member 5 is adjusted. In still further embodiments, the height or depth of well terminal member 14 and the vertical tension applied to lower connecting member 5 are held approximately constant, while lateral adjustments are performed using lateral stabilizer 6 and one or more of tension lines 7.

**[0020]** In certain embodiments, one or more lateral tension lines 7 are individually adjustable, whereas in other embodiments, the tension lines 7 are collectively adjustable. In further embodiments, one or more tension lines 7 are both individually and collectively adjustable. In still further embodiments, the one or more lateral stabilizers 6 are disposed in communication with a tension measuring means, so that a fixed or predetermined amount of lateral tension can be applied to lower connecting member 5 in order to better control system offset. In some embodiments, the tension lines 7 are anchored to the sea floor by means of an anchoring member 8, for example, a suction type anchor, or alternatively, a mechanical or conventional deadweight type anchor.

**[0021]** In a presently preferred embodiment, adjustable buoyancy chamber 9 is approximately annular in shape, so that lower connecting member 5 can be passed through a void longitudinally disposed in a central portion of the device. In further embodiments, adjustable buoyancy chamber 9 further comprises a plurality of inner chambers. In still further embodiments, each of the chambers is independently operable, and different amounts of air or gas (or another fluid) are disposed in the chambers to provide greater adjustable buoyancy control. In one example embodiment, adjustable buoyancy chamber 9 further comprises a fluid ballast that can be ejected from the chamber, thereby achieving greater chamber buoyancy and lending additional vertical tension to lower connecting member 5. Those of ordinary skill in the art will appreciate that many appropriate fluid ballast can be used to increase or retard buoyancy; for example, compressed air is an appropriate fluid that is both inexpensive and readily available.

**[0022]** In some embodiments, adjustable buoyancy chamber 9 further comprises a ballast input valve, so that a fluid ballast can be injected into the chamber from an external source, for example, through an umbilical line run to the surface or a remote operated vehicle, so that an operator can deliver a supply of compressed gas to the chamber via the umbilical, thereby adjusting buoyancy characteristics as desired. In other embodiments, the fluid input valve is disposed in communication with one or more pumps or compressors, so that the fluid ballast is delivered to the chamber under greater pressure, thereby effecting the desired change in buoyancy more quickly and reliably.

**[0023]** In other embodiments, adjustable buoyancy chamber 9 further comprises a ballast output valve, so

that ballast can be discharged from the chamber. In instances where air or another light fluid is injected into the chamber while water or another heavy liquid is discharged, the chamber will become more buoyant and increase vertical tension on lower connecting member 5. Conversely, if water or another heavy liquid is injected into the chamber while air is bled out, the chamber will lose buoyancy, thereby lessening vertical tension on lower connecting member 5.

**[0024]** In alternative embodiments, the ballast output valve is disposed in communication with one or more pumps or compressors, so that ballast is ejected from the chamber in a more reliable and controlled manner. In some embodiments, the ballast output valve is disposed in communication with an umbilical, so that ballast ejected from the chamber can be recovered or recycled at the surface. In any event, a principle advantage of the present invention is that adjustments to the chamber's buoyancy and tensioning properties, and the ability to control the height of the well terminal member 14, can be performed at any time during either exploration or production, due to the various ballast input and output control means disposed about the body of the chamber.

**[0025]** In further embodiments, adjustable buoyancy chamber 9 is further disposed in communication with one or more tension lines 10 provided to anchor the adjustable buoyancy chamber to the sea floor. As before, tension lines 10 are anchored to the sea floor using known anchoring technology, for example, suction anchors or dead weight type anchors, *etc.* The one or more tension lines 10 can also provide additional lateral stability for the system, especially during operations in which more than one well is being worked. In one embodiment, the one or more tension lines 10 are run from the adjustable buoyancy chamber 9 to the surface, and then moored to other buoys or a surface vessel, *etc.*, so that even greater lateral tension and system stability are achieved. In further embodiments, the tension lines 10 are individually adjustable, whereas in other embodiments, the tension lines 10 are collectively controlled. In still further embodiments, the one or more tension lines 10 are both individually and collectively adjustable.

**[0026]** In one example embodiment, adjustable buoyancy chamber 9 is disposed in communication with a vertical tension receiving member 11. In another embodiment, the vertical tension receiving member 11 is equipped with a tension measuring means (*e.g.*, a load cell, strain gauge, *etc.*), so that vertical tension applied to lower connecting member 5 is imparted in a more controlled and efficient manner.

**[0027]** In another embodiment, the buoyant force applied to tension receiving member 11 is adjusted by varying the lengths of tension lines 10, while the buoyancy of adjustable buoyancy chamber 9 is held approximately constant. In a further embodiment, the buoyancy of adjustable buoyancy chamber 9 is controlled by means of one or more individually selectable ballast exhaust ports disposed about the body of the chamber, which vent ex-

cess ballast fluid to the surrounding sea. In still further embodiments, the open or closed state of the ballast exhaust ports are individually controlled using port controllers known to those of ordinary skill in the art (*e.g.*, plugs, seacocks, *etc.*)

**[0028]** In a presently preferred embodiment, the system is disposed so that a well terminal member 14 installed above buoyancy chamber 9 is submerged to a depth at which maintenance and testing can be carried out by SCUBA divers using lightweight, flexible diving equipment, for example, at a depth of about 30 to 91 m (100 to 300 feet) beneath the surface. In some embodiments, the well terminal member 14 is submerged only to the minimum depth necessary to provide topside access to the hulls of various surface vessels servicing the well, meaning that well terminal member 14 could also be disposed at a much shallower depth, for example, a depth of about 15 to 30 m (50 to 100 feet). In alternative embodiments, well terminal member 14 is disposed at depths of less than 15 m (50 feet), or greater than 91 m (300 feet), depending upon the actual conditions surrounding operations. In still further embodiments, well terminal member 14 is disposed either at the surface or above the surface of the water, and a blowout preventer or a production tree is installed by workers operating aboard a service platform or surface vessel. This "damp tree" model avoids the need to assemble long subsurface riser stacks, as would generally be required during deep-water operations. Moreover, disposing the well terminal member at or near the surface also permits testing and maintenance to be carried out by SCUBA divers or surface crews, without the need for expensive and time-consuming remote operated vehicle operations.

**[0029]** In some embodiments, well terminal member 14 further comprises either a blowout preventer or a production tree. In a presently preferred embodiment, however, well terminal member 14 further comprises a combined blowout preventer and production tree assembly configured so as to facilitate simplified well intervention operations.

**[0030]** In some embodiments, lower connecting member 5 terminates within the void formed in a center portion of the annular chamber 9, at which point an upper connecting member 12 becomes the means by which fluids are transported up to the wellhead. In other embodiments, lower connecting member 5 does not terminate within the void formed in a center portion of the annular chamber, but instead runs through the void and is subsequently employed as an upper connecting member 12 disposed between the chamber and the wellhead. In other embodiments, a vertical tension receiving member 11 is disposed between the buoyancy chamber 9 and upper connecting member 12, so that the chamber's buoyant forces are transferred to the vertical tension receiving means 11, thereby applying vertical tension to the drilling or production string extended below the chamber.

**[0031]** In further embodiments, upper connecting member 12 further comprises a well isolation member

13, e.g., one or more ball valves or blowout preventers, used to halt fluid flow in the event that well terminal member 14 is either removed or disabled, for example, during testing and maintenance operations. Those of ordinary skill in the art will appreciate that the precise types and exact locations of isolation valves 13 employed in the system are variable and flexible, the only real requirement being that the valves are capable of allowing or preventing fluid flow from the well 1 during periods in which testing or maintenance, or even an emergency safety condition, are present.

**[0032]** For example, well terminal member 14 can be equipped with a production tree so that a production hose disposed on a surface vessel can be attached to the system and production can commence. Alternatively, well terminal member 14 can terminate in a blowout preventer, so that the well will not blow out during drilling operations. In other embodiments, well terminal member 14 terminates in a combined production tree and blowout preventer assembly to facilitate simplified well intervention operations.

Turning now to the specific, non-limiting embodiments of the invention depicted in Figures 2A and 2B, a system and method of establishing a height-variable well terminal member is provided, comprising a lower fluid transport pipe 21, an inner well casing 22, an outer well casing 23, and a wellhead 24. In some embodiments, a well isolation member 25 is disposed above the wellhead 24, so that the well can be closed off or shut in if desired.

**[0033]** In the example embodiment depicted in Figure 2A, well isolation member 25 further comprises one or more ball valves that can be adjustably opened or closed as desired by an operator. A lower connecting member 26 having one or more interior seals 27 and an interior polished bore 28 houses a fluid transport member 29 such that the height of fluid transport member 29 is variably adjustable within a body portion of lower connecting member 26 in response to vertical lifting forces imparted by adjustable buoyancy chamber 30. Various lengths of pipe define the height of an upper connecting member disposed between the buoyancy chamber 30 and a well terminal member 36. In some embodiments, an upper well isolation member 35, such as a ball valve or a blowout preventer, is disposed in communication with the upper connecting member between buoyancy chamber 30 and well terminal member 36.

**[0034]** In some embodiments, the system is moored to the sea floor using one or more mooring lines 31 connected to a first vertical tension receiving means 32a, while buoyancy chamber 30 is raised or lowered by either spooling-out or reeling-in lengths of one or more tension lines 37 disposed between a second vertical tension receiving means 32b and a chamber height adjustment means 33. As adjustable buoyancy chamber 30 rises, vertical tension is applied to vertical tension receiving member 34, which in turn lifts well terminal member 36 up toward the surface.

**[0035]** As seen in the example embodiment depicted

in Figure 2B, the height of both the well terminal member 36 and fluid transport member 29 are vertically adjusted by increasing the length of tension lines 37 using chamber height adjustment means 33, even as vertical and lateral tension on mooring lines 31 and tension lines 37 remains approximately constant. In one embodiment, vertical tension on lower connecting member 26 is also kept approximately constant during this process, since fluid transport member 29 is moved vertically within a body portion of lower connecting member 26. In another embodiment, a second, lower adjustable buoyancy chamber is added to the system to maintain tension on lower connecting member 26, while the height of the well terminal member is adjusted as described above.

**[0036]** The foregoing specification is provided for illustrative purposes only, and is not intended to describe all possible aspects of the present invention. Moreover, while the invention has been shown and described in detail with respect to several exemplary embodiments, those of ordinary skill in the pertinent arts will appreciate that minor changes to the description, and various other modifications, omissions and additions may also be made without departing from the scope thereof.

## Claims

1. An offshore exploration and production system, the system comprising:
  - a. a well casing (2, 22) disposed in communication with an offshore well (1);
  - b. at least one buoyancy chamber (9, 30);
  - c. a lower connecting member (5, 26) disposed between said well casing (2, 22) and said buoyancy chamber (9, 30); and wherein
  - d. said at least one buoyancy chamber (9, 30) is disposed in communication with at least one tension line (10, 31) provided to anchor the at least one buoyancy chamber (9, 30) to the sea floor; **characterized in that**
  - e. said at least one buoyancy chamber (9, 30) is adjustable by varying the length of the at least one tension line (10, 31).
2. The system of claim 1, further comprising:
  - a. one or more adjustable buoyancy chambers (9); or
  - b. a well casing (2) disposed in communication with a hole (3) bored into an associated sea floor surface; or
  - c. a well isolation member (4) disposed between said adjustable buoyancy chamber (9) and said lower connecting member (5);
  - i. said well isolation member (4) preferably further comprises one or more ball valves

- or a blowout preventer preferably comprising a shear ram; or
- ii. said lower connecting member (5) preferably further comprises a receiving member for receiving an attachment member disposed on said isolation member (4) or an attachment member for attaching said lower connecting member (5) to a receiving member disposed on said isolation member (4).
- 5
- 10
- 15
- 20
- 25
- 30
- 35
- 40
- 45
- 50
- 55
- 60
- 65
- 70
- 75
- 80
- 85
- 90
- 95
- 100
- 105
- 110
- 115
- 120
- 125
- 130
- 135
- 140
- 145
- 150
- 155
- 160
- 165
- 170
- 175
- 180
- 185
- 190
- 195
- 200
- 205
- 210
- 215
- 220
- 225
- 230
- 235
- 240
- 245
- 250
- 255
- 260
- 265
- 270
- 275
- 280
- 285
- 290
- 295
- 300
- 305
- 310
- 315
- 320
- 325
- 330
- 335
- 340
- 345
- 350
- 355
- 360
- 365
- 370
- 375
- 380
- 385
- 390
- 395
- 400
- 405
- 410
- 415
- 420
- 425
- 430
- 435
- 440
- 445
- 450
- 455
- 460
- 465
- 470
- 475
- 480
- 485
- 490
- 495
- 500
- 505
- 510
- 515
- 520
- 525
- 530
- 535
- 540
- 545
- 550
- 555
- 560
- 565
- 570
- 575
- 580
- 585
- 590
- 595
- 600
- 605
- 610
- 615
- 620
- 625
- 630
- 635
- 640
- 645
- 650
- 655
- 660
- 665
- 670
- 675
- 680
- 685
- 690
- 695
- 700
- 705
- 710
- 715
- 720
- 725
- 730
- 735
- 740
- 745
- 750
- 755
- 760
- 765
- 770
- 775
- 780
- 785
- 790
- 795
- 800
- 805
- 810
- 815
- 820
- 825
- 830
- 835
- 840
- 845
- 850
- 855
- 860
- 865
- 870
- 875
- 880
- 885
- 890
- 895
- 900
- 905
- 910
- 915
- 920
- 925
- 930
- 935
- 940
- 945
- 950
- 955
- 960
- 965
- 970
- 975
- 980
- 985
- 990
- 995
- 1000

- connecting member (12), said upper connecting member (12) is preferably disposed in communication with a well terminal member (14) preferably comprising;
- i. a production tree; or
  - ii. a blowout preventer; or
  - iii. a combined production tree and blowout preventer assembly.
- 5
9. The system of claim 1, wherein a well terminal member (14) disposed above said adjustable buoyancy chamber (9) is disposed above a surface of a body of water.
10. A method of installing and maintaining an offshore exploration and production system, the method comprising the steps of
- a. disposing a well casing (2, 22) in communication with an offshore well;
  - b. disposing a lower connecting member (5) between said well casing (2) and one or more buoyancy chambers (9, 30);
  - c. disposing said at least one buoyancy chamber (9, 30) in communication with at least one tension line (10, 31) and anchoring the at least one buoyancy chamber (9, 30) to the sea floor; **characterized by** the further step of
  - e. adjusting said at least one buoyancy chamber (9, 30) by varying the length of the at least one tension line (10, 31).
- 10
11. The method of claim 10, further comprising the steps of
- a. disposing one or more adjustable buoyancy chambers (9) in communication with said well casing (2), the method preferably further comprising cementing said well casing (2) into a hole (3) bored into a sea floor surface; or
  - b. disposing a well isolation member between said adjustable buoyancy chamber (9) and said lower connecting member (5), preferably further comprising;
    - i. disposing a well isolation member (4) having one or more ball valves; or
    - ii. disposing a well isolation member (4) having a blowout preventer, said disposing a blowout preventer preferably further comprises disposing a blowout preventer having a shear ram; or
    - iii. disposing a well isolation member (4) having an attachment member for attaching said well isolation member to a receiving member disposed on said lower connecting member; or
- 15
12. The method of claim 10, wherein said disposing a lower connecting member (5) further comprises the steps of
- a. disposing a riser; or
  - b. disposing a riser pipe; or
  - c. disposing a casing; or
  - d. disposing a fluid transport member housed within an interior portion of said lower connecting member, the method preferably further comprising adjusting the length of one or more associated tension lines so as to variably adjust the height of said fluid transport member; or
  - e. disposing a lower connecting member in communication with one or more lateral stabilizers (6), the method preferably further comprising the steps of
    - i. disposing a lower connecting member (5) in communication with one or more adjustable lateral stabilizers; or
    - ii. disposing said one or more lateral stabilizers in communication with one or more tension lines (7), the method preferably further comprising disposing said one or more lateral stabilizers (6) in communication with one or more adjustable tension lines or the method preferably further comprising disposing said one or more tension lines (7) in communication with one or more anchoring members (8).
- 20
13. The method of claim 11, further comprising the steps of
- a. disposing one or more approximately annular adjustable buoyancy chambers (9), the method preferably further comprising disposing said lower connecting member (5) longitudinally through a void formed in said one or more approximately annular adjustable buoyancy chambers; or
  - b. disposing one or more adjustable buoyancy chambers (9) having a plurality of inner chambers.
- 25
14. The method of claim 10, further comprising disposing an adjustable buoyancy chamber (9) having;
- a. a fluid ballast, said disposing an adjustable buoyancy chamber (9) having a fluid ballast preferably further comprises disposing an adjustable buoyancy chamber (9) having a supply of
- 30
- 35
- 40
- 45
- 50
- 55

- compressed gas; or
- b. a fluid input valve, the method preferably further comprising;
- i. disposing said fluid input valve in communication with one or more of an umbilical and a remote operated vehicle; or
  - ii. disposing said fluid input valve in communication with a pump; or
  - iii. disposing said fluid input valve in communication with a compressor; or
- c. a fluid output valve, the method preferably further comprising the steps of
- i. disposing said fluid output valve in communication with one or more of an umbilical and a remote operated vehicle; or
  - ii. disposing said fluid output valve in communication with a pump; or
  - iii. disposing said fluid output valve in communication with a compressor.
- 15.** The method of claim 10, further comprising disposing an adjustable buoyancy chamber in communication with;
- a. one or more adjustable tension lines (10), the method preferably further comprising the steps of
    - i. disposing an adjustable buoyancy chamber (9) in communication with one or more individually adjustable tension lines; or
    - ii. disposing said one or more tension lines (10) in communication with one or more anchoring members; or
  - b. a tension receiving member (11), the method preferably further comprising disposing said tension receiving member (11) in communication with a tension measuring means, said disposing said tension receiving member (11) in communication with a tension measuring means preferably further comprises disposing said tension receiving member in communication with a load cell; or
  - c. submersing an adjustable buoyancy chamber in a body of water to a depth of between about 30 m and about 91 m; or
  - d. submersing an adjustable buoyancy chamber in a body of water to a depth of less than about 30 m; or
  - e. submersing an adjustable buoyancy chamber in a body of water to a depth of greater than about 91 m; or
  - f. disposing a well terminal member (14) above said adjustable buoyancy chamber (9) in a man-

ner such that said well terminal member (14) is disposed above a surface of a body of water; or

g. disposing an adjustable buoyancy chamber (9) in communication with a well isolation member (4), the method preferably further comprising;

- i. disposing an adjustable buoyancy chamber in communication with a well isolation member (4) having a ball valve; or
- ii. disposing an adjustable buoyancy chamber in communication with a well isolation member (4) having a blowout preventer, the method preferably further comprising disposing an adjustable buoyancy chamber (9) in communication with a blowout preventer having a shear ram; or

h. disposing an adjustable buoyancy chamber (9) in communication with an upper connecting member (12), the method preferably further comprising disposing said upper connecting member (12) in communication with a well terminal member (14), the method preferably further comprising;

- i. disposing said upper connecting member (12) in communication with a blowout preventer; or
- ii. disposing said upper connecting member (12) in communication with a production tree; or
- iii. disposing said upper connecting member (12) in communication with a combined production tree and blowout preventer assembly.

**16.** The use of an offshore exploration and production system according to claims 1 to 9, wherein the use of said system being for the exploration and production of oil and gas.

#### Patentansprüche

- 1.** Ein ablandiges Untersuchungs- und Produktionssystem, wobei das System aufweist:
- a) Ein Bohrlochgehäuse (2, 22), angeordnet in Kommunikation mit einem ablandigen Bohrloch (1);
  - b) zumindest einen Schwimmer (9, 30);
  - c) ein unteres Verbindungselement (5, 26), angeordnet zwischen dem Bohrlochgehäuse (2, 22) und dem Schwimmer (9, 30); und wobei
  - d) der zumindest eine Schwimmer (9, 30) in Kommunikation mit zumindest einer Spannungsleitung (10, 31), die bereitgestellt ist, den

- zumindest einen Schwimmer (9, 30) auf den Meeresgrund zu verankern, angeordnet ist; **dadurch gekennzeichnet dass**
- e) der zumindest eine Schwimmer (9, 30) anpassbar durch das Variieren der Länge der zumindest einen Spannungsleitung (10, 31) ist.
2. Das System gemäß Anspruch 1, weiterhin aufweisend:
- a) Eine oder mehrere anpassbare Schwimmer (9); oder
- b) ein Bohrlochgehäuse (2), das in Kommunikation mit einem Loch (3), das in der dazugehörigen Meeresgrundoberfläche gebohrt ist, angeordnet ist; oder
- c) ein Bohrlochisolationselement (4), das zwischen dem angleichbaren Schwimmer (9) und dem unteren Verbindungselement (5) angeordnet ist, wobei
- i. das Bohrlochisolationselement (4) weiterhin vorzugsweise eine oder mehrere Kugelventile oder einen Bohrlchschieber, der vorzugsweise einen Schubstampfer enthält, aufweist; oder
- ii. das untere Befestigungselement (5) weiterhin vorzugsweise ein Aufnahmeelement für das Aufnehmen eines Anbringungselements aufweist, das an dem Isolationselement (4) oder an einem Anbringungselement für das Anbringen des unteren Verbindungselement (5) an ein Aufnahmeelement, das an dem Isolationselement (4) angeordnet ist, angebracht ist.
3. Das System gemäß Anspruch 1, wobei das untere Verbindungselement (5) weiterhin aufweist:
- a) Eine Steigleitung; oder
- b) eine Steigrohrleitung; oder
- c) ein Gehäuse; oder
- d) ein Flüssigkeitstransportelement, das innerhalb eines inneren Anteils des unteren Verbindungselements angeordnet ist, wobei das Flüssigkeitstransportelement vorzugsweise höhenanpassbar ist in Reaktion auf einen Auftrieb, der durch den anpassbaren Schwimmer (9) vermittelt wird.
4. Das System gemäß Anspruch 1, wobei das untere Verbindungselement (5) in Kommunikation mit einem oder mehreren lateralen Stabilisatoren (6) angeordnet ist, wobei
- a) weiterhin der eine oder mehrere laterale Stabilisatoren (6) vorzugsweise einen oder mehrere anpassbare laterale Stabilisatoren aufweist;
- oder
- b) wobei vorzugsweise der eine oder die mehreren lateralen Stabilisatoren (6) in Kommunikation mit einer oder mehreren Spannungsleitungen (7) angeordnet sind,
- i. wobei die eine oder mehrere Spannungsleitungen (7) weiterhin eine oder mehrere individuell anpassbare Spannungsleitungen aufweisen; oder
- ii. wobei vorzugsweise die eine oder mehrere Spannungsleitungen (7) in Kommunikation mit einem oder mehreren Befestigungselementen (8) angeordnet sind.
5. Das System gemäß Anspruch 2, wobei der eine oder die mehreren anpassbaren Schwimmer (9) weiterhin eine oder mehrere ungefähr ringförmig anpassbare Schwimmer aufweisen, wobei das untere Verbindungselement (5) vorzugsweise longitudinal durch einen Hohlraum, der in dem einen oder mehreren ungefähr ringförmig angepassten Schwimmern geformt ist, angeordnet ist.
6. Das System gemäß Anspruch 2, wobei eine oder mehrere des einen oder der mehreren anpassbaren Schwimmer (9) weiterhin eine Vielzahl von inneren Kammern aufweisen.
7. Das System gemäß Anspruch 1, wobei der anpassbare Schwimmer weiterhin aufweist:
- a) Einen Flüssigkeitsballast, der vorzugsweise eine Einspeisung von komprimiertem Gas aufweist; oder
- b) ein Ballasteingangsventil,
- i. wobei vorzugsweise das Ballasteingangsventil in Kommunikation mit einem oder mehreren Versorgungs- oder entfernt operierenden Fahrzeugen steht; oder
- ii. wobei das Ballasteingangsventil vorzugsweise in Kommunikation mit einer Pumpe angeordnet ist; oder
- iii. wobei vorzugsweise das Ballasteingangsventil in Kommunikation mit einem Kompressor angeordnet ist; oder
- iv. wobei das Ballasteingangsventil vorzugsweise in Kommunikation mit einem Kompressor angeordnet ist; oder
- c) ein Ballastausgangsventil,
- i. wobei das Ballastausgangsventil vorzugsweise in Kommunikation mit einem oder mehreren Versorgungs- oder entfernt operierenden Fahrzeugen steht; oder
- ii. wobei das Ballastausgangsventil vor-

- zugsweise in Kommunikation mit einer Pumpe angeordnet ist; oder  
 iii. wobei vorzugsweise das Ballastausgangsventil in Kommunikation mit einem Kompressor angeordnet ist;
8. Das System gemäß Anspruch 1, wobei der anpassbare Schwimmer:
- a) In Kommunikation mit einer oder mehreren Spannungsleitungen (10) angeordnet ist,
- i. wobei die eine oder mehreren Spannungsleitungen (10) vorzugsweise weiterhin eine oder mehrere individuell anpassbare Spannungsleitungen aufweisen; oder  
 ii. wobei vorzugsweise eine oder mehrere Spannungsleitungen (10) in Kommunikation mit einer oder mehreren Befestigungselementen verankert ist; oder
- b) in Kommunikation mit einem vertikalen Spannungsaufnahmeelement (11) angeordnet ist, wobei das Spannungsaufnahmeelement vorzugsweise in Kommunikation mit einem Spannungsmessmittel, das vorzugsweise eine Auflagezelle aufweist, angeordnet ist; oder
- c) untergetaucht ist in einem Wasserkörper bei einer Tiefe zwischen ungefähr 30 Metern und ungefähr 91 Metern; oder
- d) untergetaucht ist in einem Wasserkörper bei einer Tiefe von weniger als ungefähr 30 Metern; oder
- e) untergetaucht ist in einem Wasserkörper bei einer Tiefe größer als ungefähr 91 Meter; oder
- f) in Kommunikation mit einem oberen Bohrlochisolationselement angeordnet ist,
- i. vorzugsweise ein Kugelventil aufweisend; oder  
 ii. vorzugsweise einen Bohrlochschieber, der vorzugsweise einen Schubstampfer aufweist, aufweisend; oder
- g) in Kommunikation mit einem oberen Verbindungselement (12) angeordnet ist, wobei vorzugsweise das obere Verbindungselement (12) in Kommunikation mit einem Bohrlochanschlusselement (14) angeordnet ist, vorzugsweise aufweisend:
- i. einen Produktionsbaum; oder  
 ii. einen Bohrlochschieber; oder  
 iii. eine kombinierte Produktionsbaum- und Bohrlochschiebersvorrichtung.
9. Das System gemäß Anspruch 1, wobei ein Bohrlochanschlusselement (14), das oberhalb des anpassbaren Schwimmers (9) angeordnet ist, oberhalb einer Oberfläche des Wasserkörpers angeordnet ist.
10. Ein Verfahren für das Installieren und Aufrechterhalten eines ablandigen Untersuchungs- und Produktionssystems, wobei das Verfahren die Schritte des
- a) Anordnens eines Bohrlochgehäuses (2, 22) in Kommunikation mit einem ablandigen Bohrloch aufweist;  
 b) Anordnens eines unteren Verbindungselements (5) zwischen dem Bohrlochgehäuse (2) und einem oder mehreren Schwimmern (9, 30) aufweist;  
 c) Anordnens von zumindest einem Schwimmer (9, 30) in Kommunikation mit zumindest einer Spannungsleitung (10, 31) und das Verankern des zumindest einen Schwimmers (9, 30) auf dem Meeresgrund aufweist, charakterisiert durch den weiteren Schritt des  
 e) Anpassens des zumindest einen Schwimmers (9, 30) durch das Variieren der Länge der zumindest einen Spannungsleitung (10, 31).
11. Das Verfahren gemäß Anspruch 10, weiterhin aufweisend die Schritte des
- a) Anordnens eines oder mehreren anpassbaren Schwimmer (9) in Kommunikation mit dem Bohrlochgehäuse (2), wobei das Verfahren vorzugsweise weiterhin das Zementieren des Bohrlochgehäuses (2) in ein Loch (3), das in die Meeresgrundoberfläche gebohrt wird, aufweist; oder  
 b) Anordnens eines Bohrlochisolationselements zwischen dem angleichbaren Schwimmer (9) und dem unteren Verbindungselement (5), vorzugsweise weiterhin aufweisend;
- i. Anordnen eines Bohrlochisolationselements (4), das eine oder mehrere Kugelventile aufweist; oder  
 ii. Anordnen eines Bohrlochisolationselements (4), das einen Bohrlochschieber aufweist, wobei das Anordnen einer Bohrlochschieber weiterhin vorzugsweise das Anordnen einer Bohrlochschiebers mit einem Schubstampfer aufweist; oder  
 iii. Anordnen eines Bohrlochisolationselements (4), das ein Anbringungselement für das Anbringen des Bohrlochisolationselements an einem Empfangselement, das an dem unteren Verbindungselement angebracht ist, aufweist; oder  
 iv. Anbringen eines Bohrlochisolationselements (4), das ein Empfangselement für das Empfangen eines Anbringungselements, das an dem unteren Verbindungselement (5) angebracht ist, aufweist.

12. Das Verfahren gemäß Anspruch 10, wobei das Anordnen eines unteren Verbindungselements (5) weiterhin die Schritte des

- a) Anordnens einer Steigleitung; oder 5
- b) Anordnens einer Steigrohrleitung; oder
- c) Anordnens eines Gehäuses; oder
- d) Anordnens eines Flüssigkeitstransportelements, das innerhalb eines inneren Anteils des unteren Verbindungselements beherbergt ist aufweist, wobei das Verfahren vorzugsweise weiterhin das Anpassen der Länge von einer oder mehreren zugeordneten Spannungsleitungen umfasst, sodass die Höhe des Flüssigkeitstransportelements variierbar anpassbar ist; oder 10
- e) Anordnens eines unteren Verbindungselements in Kommunikation mit einem oder mehreren lateralen Stabilisatoren (6), wobei das Verfahren vorzugsweise weiterhin die Schritte des 15

- i. Anordnens eines unteren Verbindungselements (5) in Kommunikation mit einem oder mehreren angleichbaren lateralen Stabilisatoren oder 25
- ii. Anordnens des einen oder mehreren lateralen Stabilisatoren in Kommunikation mit einer oder mehreren Spannungsleitungen (7) aufweist, wobei weiterhin vorzugsweise das Verfahren das Anordnen von einem oder mehreren lateralen Stabilisatoren (6) in Kommunikation mit einer oder mehreren anpassbaren Spannungsleitungen aufweist oder das Verfahren vorzugsweise weiterhin das Anordnen der einen oder mehreren Spannungsleitungen (7) in Kommunikation mit einem oder mehreren Verankerungselementen (8) aufweist. 30

13. Das Verfahren gemäß Anspruch 11, weiterhin aufweisend die Schritte des

- a) Anordnens eines oder mehrerer ungefähr ringförmigen anpassbaren Schwimmer (9), wobei das Verfahren vorzugsweise weiterhin das Anordnen des unteren Verbindungselements (5) longitudinal durch einen Hohlraum, der in einem oder mehreren ungefähr ringförmigen anpassbaren Schwimmer geformt ist, aufweist; oder 45
- b) Anordnens einer oder mehrerer anpassbarer Schwimmer (9), die eine Vielzahl von inneren Kammern aufweisen. 50

14. Das Verfahren gemäß Anspruch 10, weiterhin aufweisend das Anordnen eines angleichbaren Schwimmers (9), der

a) einen Flüssigkeitsballast hat, wobei das Anordnen des anpassbaren Schwimmers (9), der einen Flüssigkeitsballast hat, weiterhin vorzugsweise das Anordnen eines anpassbaren Schwimmers (9), der eine Versorgung zu kompressiblem Gas hat, aufweist; oder

b) ein Flüssigkeitseinlassventil aufweist, wobei das Verfahren weiterhin vorzugsweise aufweist:

- i. Das Anordnen des Flüssigkeitseinlassventils in Kommunikation mit einem oder mehreren Versorgungs- oder entfernt operierenden Fahrzeugen; oder
- ii. Anordnens des Flüssigkeitseinlassventils in Kommunikation mit einer Pumpe; oder
- iii. Anordnens des Flüssigkeitseinlassventils in Kommunikation mit einem Kompressor; oder

c) ein Flüssigkeitsauslassventil hat, wobei das Verfahren weiterhin vorzugsweise die Schritte des

- i. Anordnens des Flüssigkeitsauslassventils in Kommunikation mit einem oder mehreren Versorgungs- oder entfernt operierenden Fahrzeugen aufweist; oder
- ii. Anordnens des Flüssigkeitsauslassventils in Kommunikation mit einer Pumpe aufweist; oder
- iii. Anordnens des Flüssigkeitsauslassventils in Kommunikation mit einem Kompressor aufweist.

15. Das Verfahren gemäß Anspruch 10, weiterhin aufweisend das Anordnen eines anpassbaren Schwimmers in Verbindung mit

a) einer oder mehreren anpassbaren Spannungsleitungen (10), wobei das Verfahren vorzugsweise weiterhin die Schritte des

- i. Anordnens eines anpassbaren Schwimmers (9) in Kommunikation mit einer oder mehreren individuell anpassbaren Spannungsleitungen aufweist; oder
- ii. Anordnens eines oder mehrerer Spannungsleitungen (10) in Kommunikation mit einem oder mehreren Verankerungselementen aufweist; oder

b) ein Spannungsempfangselement (11), wobei das Verfahren weiterhin vorzugsweise das Anordnen des Spannungsempfangselements (11) in Kommunikation mit einem Spannungsmessmittel aufweist, wobei das Anordnen des Spannungsempfangsmittels (11) in Kommunikation mit einem Spannungsmessmittel vor-

zugsweise weiterhin das Anordnen des Spannungsempfangelements in Kommunikation mit einer Ladungszelle aufweist; oder

c) dem Untertauchen eines anpassbaren Schwimmers in einem Wasserkörper auf eine Tiefe zwischen 30 Meter und ungefähr 91 Meter; oder

d) dem Untertauchen eines anpassbaren Schwimmers in einem Wasserkörper auf eine Tiefe weniger als ungefähr 30 Meter; oder

e) dem Untertauchen eines anpassbaren Schwimmers in einem Wasserkörper auf eine Tiefe größer als ungefähr 91 Meter; oder

f) dem Anordnen eines Bohrlochanschlusselements (14) oberhalb des anpassbaren Schwimmers (9) in einer Weise, sodass das Bohrlochanschlusselement (14) oberhalb einer Oberfläche des Wasserkörpers angeordnet ist; oder

g) dem Anordnen eines anpassbaren Schwimmers (9) in Kommunikation mit einem Bohrlochisolationmittel (4), wobei das Verfahren weiterhin das

i. Anordnen eines anpassbaren Schwimmers in Kommunikation mit einem Bohrlochisolationmittel (4), das ein Kugelventil aufweist, aufweist; oder

ii. Anordnen eines anpassbaren Schwimmers in Kommunikation mit einem Bohrlochisolationmittel (4), das einen Bohrlochschieber aufweist, wobei das Verfahren weiterhin vorzugsweise das Anordnen eines anpassbaren Schwimmers (9) in Kommunikation mit einem Bohrlochschieber, der einen Schubstampfer aufweist, aufweist; oder

h) Anordnen eines anpassbaren Schwimmers (9) in Kommunikation mit einem oberen Verbindungselement (12), wobei das Verfahren weiterhin vorzugsweise das Anordnen des oberen Verbindungselements (12) in Kommunikation mit einem Bohrlochanschlusselement (14) aufweist, wobei das Verfahren weiterhin vorzugsweise das

i. Anordnen des oberen Verbindungselements (12) in Kommunikation mit einer Bohrlochschieber aufweist; oder

ii. das Anordnen des oberen Verbindungselements (12) in Kommunikation mit einem Produktionsbaum aufweist; oder

iii. Anordnen des oberen Verbindungselements (12) in Kommunikation mit einem kombinierten Produktionsbaum und Bohrlochschiebersvorrichtung aufweist.

16. Die Verwendung eines ablandigen Untersuchungs-

und Produktionssystems gemäß der Ansprüche 1 bis 9, wobei die Verwendung des Systems für die Untersuchung und Produktion von Öl und Gas dient.

## Revendications

1. Système d'exploration et de production en mer, d'un système comprenant :

a. un tubage de puits (2, 22) disposé en communication avec un puits en mer (1) ;

b. au moins un réservoir de flottaison (9, 30) ;

c. une pièce de liaison inférieure (5, 26) disposée entre ledit tubage de puits (2, 22) et ledit réservoir de flottaison (9, 30) ; et dans lequel

d. ledit au moins un réservoir de flottaison (9, 30) est disposé en communication avec au moins un câblé de tension (10, 31) disposé de façon à ancrer l'au moins un réservoir de flottaison (9, 30) sur le fond océanique ; **caractérisé en ce que**

e. ledit au moins un réservoir de flottaison (9, 30) est réglable par variation de la longueur de l'au moins un câble de tension (10, 31).

2. Système selon la revendication 1, comprenant en outre

a. un ou plusieurs réservoirs de flottaison réglables (9) ; ou

b. un tubage de puits (2) disposé en communication avec un trou (3) foré à l'intérieur d'une surface de fond océanique associée ; ou

c. une pièce d'isolement de puits (4), disposée entre ledit réservoir de flottaison réglable (9) et ladite pièce de liaison inférieure (5) ;

i. ladite pièce d'isolement de puits (4) comprenant de préférence en outre un ou plusieurs robinets à boisseau sphérique, ou un bloc obturateur de puits, comprenant de préférence une mâchoire de sécurité à cisaillement ; ou

ii. ladite pièce de liaison inférieure (5) comprenant en outre de préférence une pièce de réception destinée à recevoir une pièce de fixation disposée sur ladite pièce d'isolement (4), ou une pièce de fixation destinée à fixer ladite pièce de liaison inférieure (5) à une pièce de réception disposée sur ladite pièce d'isolement (4).

3. Système selon la revendication 1, dans lequel ladite pièce de liaison inférieure (5) comprend en outre

a. un riser ; ou

b. une colonne montante ; ou

- c. un tubage ; ou  
d. une pièce de transport de fluide, disposée à l'intérieur d'une partie intérieure de ladite pièce de liaison inférieure, ladite pièce de transport de fluide étant de préférence réglable en hauteur en réponse à une poussée d'Archimède conférée par ledit réservoir de flottaison réglable (9). 5
- 4.** Système selon la revendication 1, dans lequel ladite pièce de liaison inférieure (5) est disposée en communication avec un ou plusieurs stabilisateurs latéraux (6) ; 10
- a. lesdits un ou plusieurs stabilisateurs latéraux (6) comprenant en outre un ou plusieurs stabilisateurs latéraux réglables ; ou 15
- b. lesdits un ou plusieurs stabilisateurs latéraux (6) étant de préférence disposés en communication avec un ou plusieurs câbles de tension (7) ; 20
- i. lesdits un ou plusieurs câbles de tension (7) comprenant de préférence en outre un ou plusieurs câbles de tension individuellement réglables ; ou 25
- ii. lesdits un ou plusieurs câbles de tension (7) étant disposés de préférence en communication avec une ou plusieurs pièces d'ancrage (8). 30
- 5.** Système selon la revendication 2, dans lequel lesdits un ou plusieurs réservoirs de flottaison réglables (9) comprennent en outre un ou plusieurs réservoirs de flottaison réglables approximativement annulaires, ladite pièce de liaison inférieure (5) étant de préférence disposée longitudinalement à travers une cavité formée dans lesdits un ou plusieurs réservoirs de flottaison réglables approximativement annulaires. 35
- 6.** Système selon la revendication 2, dans lequel un ou plusieurs desdits un ou plusieurs réservoirs de flottaison réglables (9) comprennent en outre une pluralité de réservoirs intérieurs. 40
- 7.** Système selon la revendication 1, dans lequel ledit réservoir de flottaison réglable comprend en outre : 45
- a. un ballast fluide, comprenant de préférence un moyen d'alimentation de gaz comprimé ; ou 50
- b. une vanne d'entrée de ballast ;
- i. ladite vanne d'entrée de ballast étant de préférence disposée en communication avec un ou plusieurs d'un ombilical et d'un véhicule télécommande ; ou 55
- ii. ladite Vanne d'entrée de ballast étant de préférence disposée en communication
- avec une pompe ; ou
- iii. ladite vanne d'entrée de ballast étant de préférence disposée en communication avec un compresseur ; ou
- iv. ladite vanne d'entrée de ballast étant de préférence disposée en communication avec un compresseur ; ou
- c. une vanne de sortie de ballast ;
- i. ladite vanne de sortie de ballast étant de préférence disposée en communication avec un ou plusieurs d'un ombilical et d'un véhicule télécommandé ; ou
- ii. ladite vanne de sortie de ballast étant de préférence disposée en communication avec une pompe ; ou
- iii. ladite vanne de sortie de ballast étant de préférence disposée en communication avec un compresseur.
- 8.** Système selon la revendication 1, dans lequel ledit réservoir de flottaison réglable est : 20
- a. disposé en communication avec un ou plusieurs câbles de tension (10) ;
- i. lesdits un ou plusieurs câbles de tension (10) comprenant de préférence en outre un ou plusieurs câbles de tension individuellement réglables ; ou
- ii. lesdits un ou plusieurs câbles de tension (10) étant de préférence disposés en communication avec une ou plusieurs pièces d'ancrage ; ou
- b. disposé en communication avec une pièce verticale (11) réceptrice de tension, ladite pièce réceptrice de tension étant de préférence disposée en communication avec un moyen de mesure de la tension, qui comprend de préférence une cellule de charge ; ou
- c. immergé dans une masse d'eau à une profondeur comprise entre environ 30 m et environ 91 m ; ou
- d. immergé dans une masse d'eau à une profondeur inférieure à environ 30 m ; ou
- e. immergé dans une masse d'eau à une profondeur supérieure à environ 91 m ; ou
- f. disposé en communication avec une pièce supérieure d'isolement de puits ;
- i. comprenant de préférence un robinet à boisseau sphérique ; ou
- ii. comprenant de préférence un bloc obturateur de puits, qui de préférence comprend une mâchoire de sécurité à cisaillement ; ou

- g. disposé en communication avec une pièce de liaison supérieure (12), ladite pièce de liaison supérieure (12) étant de préférence disposée en communication avec une pièce terminale de puits (14), comprenant de préférence :
- i. une tête de production ; ou
  - ii. un bloc obturateur de puits ; ou
  - iii. un ensemble combiné de tête de production et de bloc obturateur de puits.
9. Système selon la revendication 1, dans lequel une pièce (14) terminale de puits disposée au-dessus dudit réservoir de flottaison réglable (9) est disposée au-dessus d'une surface d'une masse d'eau.
10. Procédé d'installation et de maintien d'un système d'exploration et de production en mer, le procédé comprenant les étapes de :
- a. disposition d'un tubage de puits (2, 22) en communication avec un puits en mer ;
  - b. disposition d'une pièce de connexion inférieure (5) entre ledit tubage de puits (2) et un ou plusieurs réservoirs de flottaison (9, 30) ;
  - c. disposition dudit au moins un réservoir de flottaison (9, 30) en communication avec au moins un câble de tension (10, 31), et ancrage dudit au moins un réservoir de flottaison (9, 30) sur le fond océanique ; **caractérisé par** l'étape supplémentaire de
  - e. réglage dudit au moins un réservoir de flottaison (9, 30), par une variation de la longueur de l'au moins un câble de tension (10, 31).
11. Procédé selon la revendication 10, qui comprend en outre les étapes de :
- a. disposition d'un ou plusieurs réservoirs de flottaison réglables (9) en communication avec ledit tubage de puits (2), le procédé comprenant de préférence en outre la cimentation dudit tubage de puits (2) dans un trou (3) foré dans une surface d'un fond océanique ; ou
  - b. disposition d'une pièce d'isolement de puits entre ledit réservoir de flottaison réglable (9) et ladite pièce de liaison inférieure (5), comprenant en outre de préférence :
    - i. la disposition d'une pièce (4) d'isolement de puits comportant un ou plusieurs robinets à boisseau sphérique ; ou
    - ii. la disposition d'une pièce (4) d'isolement de puits ayant un bloc obturateur de puits, ladite disposition d'un bloc opérateur de puits comprenant de préférence en outre la disposition d'un bloc obturateur de puits ayant une mâchoire de sécurité à
12. Procédé selon la revendication 10, dans lequel ladite disposition d'une pièce de liaison inférieure (5) comprend en outre les étapes de
- a. disposition d'un riser ; ou
  - b. disposition d'une colonne montante ; ou
  - c. disposition d'un tubage ; ou
  - d. disposition d'une pièce de transport de fluide, logée à l'intérieur d'une partie intérieure de ladite pièce de liaison inférieure, le procédé comprenant de préférence en outre le réglage de la longueur d'un ou plusieurs câbles de tension associés de façon à régler d'une manière variable la hauteur de ladite pièce de transport de fluide ; ou
  - e. disposition d'une pièce de liaison inférieure en communication avec un ou plusieurs stabilisateurs latéraux (6), le procédé comprenant de préférence en outre les étapes de
    - i. disposition d'une pièce de liaison inférieure (5) en communication avec un ou plusieurs stabilisateurs latéraux réglables ; ou
    - ii. disposition desdits un ou plusieurs stabilisateurs latéraux en communication avec un ou plusieurs câbles de tension (7), le procédé comprenant de préférence en outre la disposition desdits un ou plusieurs stabilisateurs latéraux (6) en communication avec un ou plusieurs câbles de tension réglables, ou le procédé comprenant de préférence en outre la disposition desdits un ou plusieurs câbles de tension (7) en communication avec une ou plusieurs pièces d'ancrage (8).
13. Procédé selon la revendication 11, comprenant en outre les étapes de
- a. disposition d'un ou plusieurs réservoirs de flottaison réglables (9) approximativement annulaires, le procédé comprenant de préférence en outre la disposition de ladite pièce de liaison inférieure (5) longitudinalement à travers une cavité formée dans lesdits un ou plusieurs réservoirs de flottaison réglables approximativement annulaires ; ou
  - b. disposition d'un ou plusieurs réservoirs de flottaison réglables (9) comportant une pluralité

de réservoirs intérieurs.

14. Procédé selon la revendication 10, comprenant en outre la disposition d'un réservoir de flottaison réglable (9) comportant
- 5
- a. un ballast fluide, ladite disposition de réservoir de flottaison réglable (9) ayant un ballast fluide comprenant de préférence en outre la disposition d'un réservoir de flottaison réglable (9) comportant une source d'alimentation en gaz comprimé ; ou
- 10
- b. une vanne d'entrée de fluide, le procédé comprenant de préférence en outre :
- 15
- i. la disposition de ladite vanne d'entrée de fluide en communication avec un ou plusieurs d'un ombilical et d'un véhicule télécommandé ; ou
- 20
- ii. la disposition de ladite vanne d'entrée de fluide en communication avec une pompe ; ou
- 25
- iii. la disposition de ladite vanne d'entrée de fluide en communication avec un compresseur ; ou
- c. une vanne de sortie de fluide, le procédé comprenant de préférence en outre les étapes de
- i. disposition de ladite vanne de sortie de fluide en communication avec un ou plusieurs d'un ombilical et d'un véhicule télécommandé ; ou
- 30
- ii. disposition de ladite vanne de sortie de fluide en communication avec une pompe ; ou
- 35
- iii. disposition de ladite vanne de sortie de fluide en communication avec un compresseur.
- 40
15. Procédé selon la revendication 10, comprenant en outre la disposition d'un réservoir de flottaison réglable en communication avec :
- a. un ou plusieurs câbles de tension réglables (10), le procédé comprenant de préférence en outre les étapes de
- 45
- i. disposition d'un réservoir de flottaison réglable (9) en communication avec un ou plusieurs câbles de tension individuellement réglables ; ou
- 50
- ii. disposition desdits un ou plusieurs câbles de tension (10) en communication avec une ou plusieurs pièces d'ancrage ; ou
- 55
- b. une pièce réceptrice de tension (11), le procédé comprenant de préférence en outre la dis-

position de ladite pièce réceptrice de tension (11) en avec un moyen de mesure de la tension, ladite disposition de ladite pièce réceptrice de tension (11) en communication avec un moyen de mesure de la tension comprenant de préférence en outre la disposition de ladite pièce réceptrice de tension en communication avec une cellule de charge ; ou

c. l'immersion d'un réservoir de flottaison réglable dans une masse d'eau à une profondeur comprise entre environ 30 m et environ 91 m ; ou

d. l'immersion d'un réservoir de flottaison réglable dans une masse d'eau à une profondeur inférieure à environ 30 m ; ou

e. l'immersion d'un réservoir de flottaison réglable dans une masse d'eau à une profondeur supérieure à environ 91 m ; ou

f. la disposition d'une pièce (14) terminale de puits au-dessus dudit réservoir de flottaison réglable (9) de façon que ladite pièce (14) terminale de puits soit disposée au-dessus d'une surface d'une masse d'eau, ou

g. la disposition d'un réservoir de flottaison réglable (9) en communication avec une pièce (4) d'isolement de puits, le procédé comprenant de préférence en outre

i. la disposition d'un réservoir de flottaison réglable en communication avec une pièce (4) d'isolement de puits ayant un robinet à boisseau sphérique ; ou

ii. la disposition d'un réservoir de flottaison réglable en communication avec une pièce (4) d'isolement de puits comportant un bloc obturateur de puits, le procédé comprenant de préférence en outre la disposition d'un réservoir de flottaison réglable (9) en communication avec un bloc obturateur de puits comportant une mâchoire de sécurité à cisaillement ; ou

h. la disposition d'un réservoir de flottaison réglable (9) en communication avec une pièce de liaison supérieure (12), le procédé comprenant de préférence en outre la disposition de ladite pièce de liaison supérieure (12) en communication avec une pièce (14) terminale de puits, le procédé comprenant de préférence en outre

i. la disposition de ladite pièce de liaison supérieure (12) en communication avec un bloc obturateur de puits ; ou

ii. la disposition de ladite pièce de liaison supérieure (12) en communication avec une tête de production ; ou

iii. la disposition de ladite pièce de liaison supérieure (12) en communication avec un ensemble combiné tête de production et

bloc obturateur de puits.

- 16.** Utilisation d'un système d'exploration et de production en mer selon les revendications 1 à 9, l'utilisation dudit système étant destinée à l'exploration et à la production de pétrole et de gaz. 5

10

15

20

25

30

35

40

45

50

55

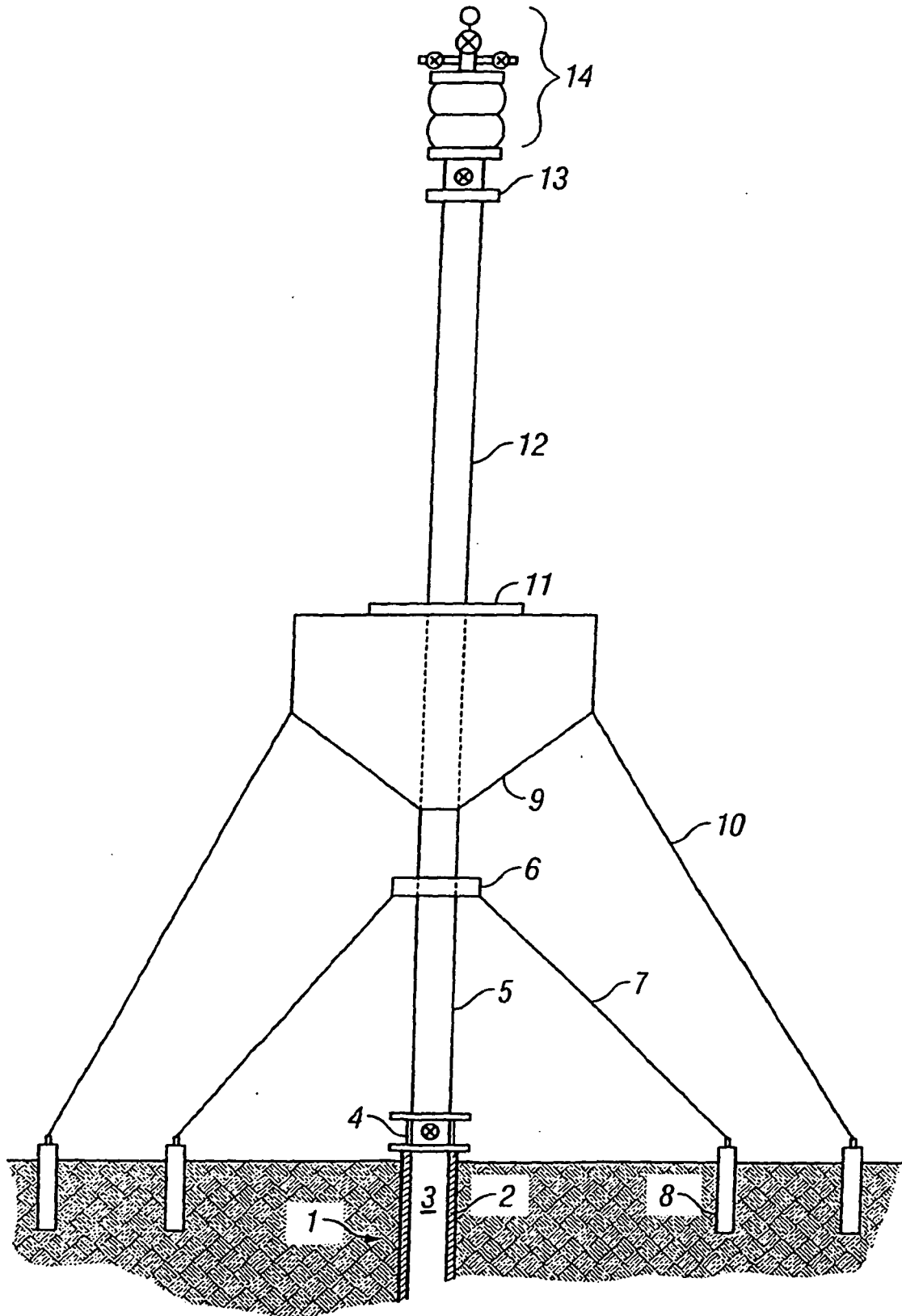

FIG. 1

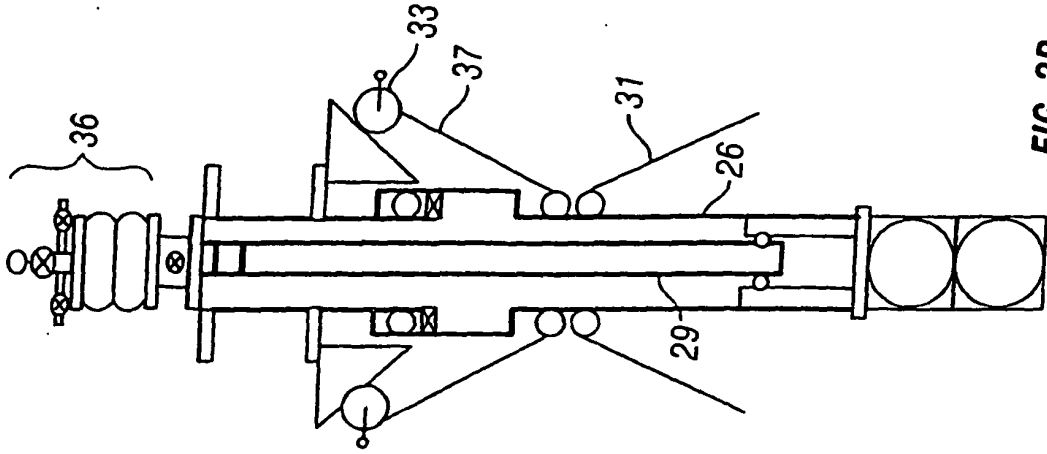

FIG. 2B

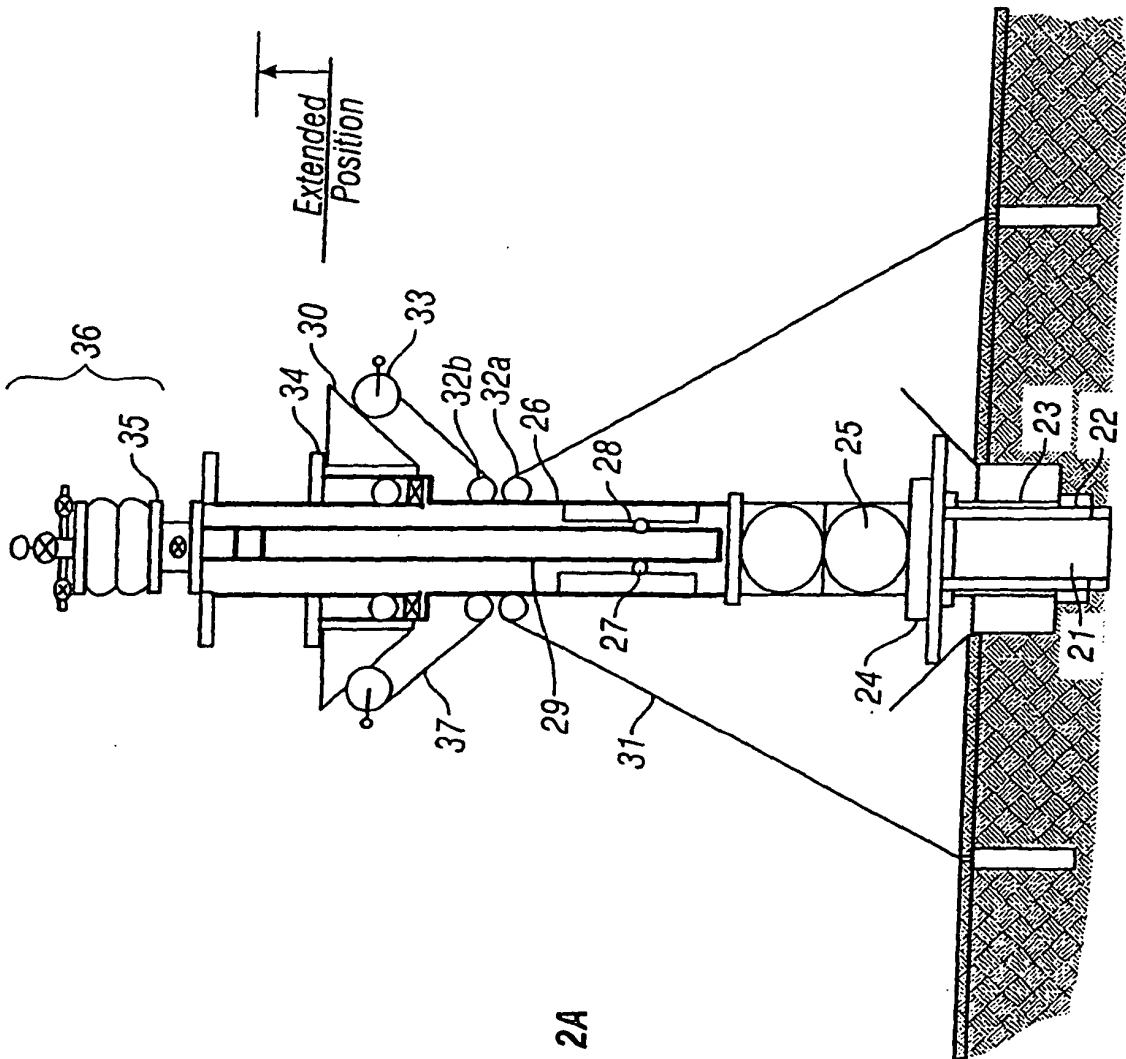

FIG. 2A

**REFERENCES CITED IN THE DESCRIPTION**

*This list of references cited by the applicant is for the reader's convenience only. It does not form part of the European patent document. Even though great care has been taken in compiling the references, errors or omissions cannot be excluded and the EPO disclaims all liability in this regard.*

**Patent documents cited in the description**

- US 20010047869 A1 [0006]
- US 4223737 US, O'Reilly [0007]
- US 6196322 B1, Magnussen [0008]
- US 4448266 A [0011]