

(19) World Intellectual Property Organization  
International Bureau



(43) International Publication Date  
22 January 2009 (22.01.2009)

PCT

(10) International Publication Number  
WO 2009/011993 A1

- (51) International Patent Classification:  
A61M 25/01 (2006.01)
  - (21) International Application Number:  
PCT/US2008/066406
  - (22) International Filing Date: 10 June 2008 (10.06.2008)
  - (25) Filing Language: English
  - (26) Publication Language: English
  - (30) Priority Data:  
60/950,702 19 July 2007 (19.07.2007) US
  - (71) Applicant (for all designated States except US): **CIRCULITE, INC.** [US/US]; 250 Pehle Avenue, Plaza 1-4th Floor, Saddle Brooke, NJ 07663 (US).
  - (72) Inventors; and
  - (75) Inventors/Applicants (for US only): **MARSEILLE, Oliver** [DE/DE]; Karl-Marx-Allee 154, 52074 Aachen (DE). **ABOULHOSN, Walid** [US/LB]; Ras-El-Meten Main Street, Btekhmay, South El-Meten (LB).
  - (74) Agents: **ROONEY, Kevin, G.** et al.; Wood, Herron & Evans, L.L.P., 441 Vine Street, 2700 Carew Tower, Cincinnati, OH 45202 (US).
  - (81) Designated States (unless otherwise indicated, for every kind of national protection available): AE, AG, AL, AM, AO, AT, AU, AZ, BA, BB, BG, BH, BR, BW, BY, BZ, CA, CH, CN, CO, CR, CU, CZ, DE, DK, DM, DO, DZ, EC, EE, EG, ES, FI, GB, GD, GE, GH, GM, GT, HN, HR, HU, ID, IL, IN, IS, JP, KE, KG, KM, KN, KP, KR, KZ, LA, LC, LK, LR, LS, LT, LU, LY, MA, MD, ME, MG, MK, MN, MW, MX, MY, MZ, NA, NG, NI, NO, NZ, OM, PG, PH, PL, PT, RO, RS, RU, SC, SD, SE, SG, SK, SL, SM, SV, SY, TJ, TM, TN, TR, TT, TZ, UA, UG, US, UZ, VC, VN, ZA, ZM, ZW.
  - (84) Designated States (unless otherwise indicated, for every kind of regional protection available): ARIPO (BW, GH, GM, KE, LS, MW, MZ, NA, SD, SL, SZ, TZ, UG, ZM, ZW), Eurasian (AM, AZ, BY, KG, KZ, MD, RU, TJ, TM), European (AT, BE, BG, CH, CY, CZ, DE, DK, EE, ES, FI, FR, GB, GR, HR, HU, IE, IS, IT, LT, LU, LV, MC, MT, NL, NO, PL, PT, RO, SE, SI, SK, TR), OAPI (BF, BJ, CF, CG, CI, CM, GA, GN, GQ, GW, ML, MR, NE, SN, TD, TG).
- Published:**  
— with international search report

(54) Title: CANNULA FOR HEART CHAMBER IMPLANTATION AND RELATED SYSTEMS AND METHODS

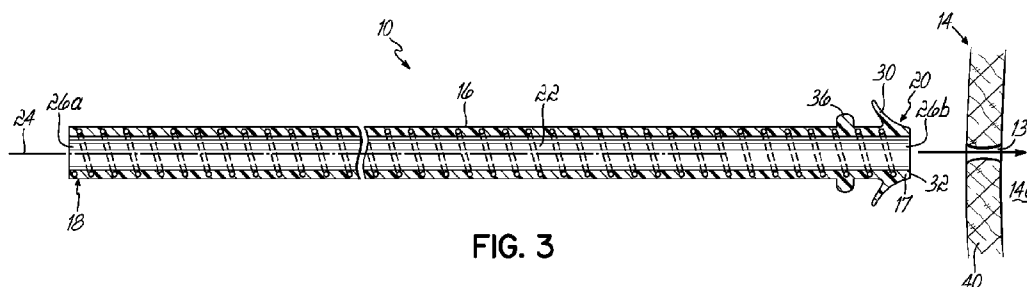

FIG. 3

(57) Abstract: A cannula for implantation into a chamber of a heart includes an elongate body having a lumen extending along a longitudinal axis, a first end, and a second end. The first and second ends define openings into the lumen and the second end includes a flat portion. A flared tip portion extends from the flat portion of the second end in a direction toward the first end, and flares radially outward from the longitudinal axis and in such direction. A ring member extends around the axis of the elongate body, spaced from the flared tip portion, and the ring member is adapted for retaining the elongate body in a position relative to a wall of the chamber. An embodiment of a flared tip portion may further include a barbed surface configured to contact tissue around an aperture in the wall of the heart when the cannula travels through the aperture.



WO 2009/011993 A1

## **CANNULA FOR HEART CHAMBER IMPLANTATION AND RELATED SYSTEMS AND METHODS**

### **Technical Field**

**[0001]** This invention generally relates to cannulae and, more particularly, for example, to cannulae for implantation into fluid communication with a chamber of a human heart.

### **Background**

**[0002]** Guided flow of blood into or out of a chamber of a human heart is sometimes necessary. For example, it may be desirable to guide or direct blood from a ventricle and into a ventricle assist device that aids the heart in delivering blood to the body. Similarly, it may be desirable to guide or direct blood to or from other locations, such as from a device and into an atrium of the heart.

**[0003]** To that end, devices such as cannulae are known that guide blood into or out of the heart. Such devices may be designed to be inserted into a chamber of a heart through an aperture in a wall of the chamber of the heart.

### **Summary**

**[0004]** In accordance with one set of embodiments, a cannula for implantation into a chamber of a heart includes an elongate body having a lumen extending along a longitudinal axis, a first end, and a second end. The first and second ends define openings into the lumen and the second end includes a flat portion. A flared tip portion extends from the flat portion of the second end in a direction toward the first end, and flares radially outward from the longitudinal axis and in such direction. A first ring member extends around the axis of the elongate body and is spaced from the flared tip portion, and the first ring member is adapted for retaining the elongate body in a position relative to a wall of the chamber.

**[0005]** In one aspect of this set of embodiments, the flared tip portion may further include a barbed surface configured to contact tissue around an aperture in the wall of the chamber of the heart when the elongate body travels through the aperture.

**[0006]** The first ring member and/or flared tip portion may include a resilient material such as silicone. Likewise, the first ring member may include a fabric adapted to be sutured to a wall of the heart. The fabric may alternatively or additionally be adapted for tissue ingrowth therethrough. The flared tip portion may include a rigid material. For example, the material may include a metal such as titanium. Alternatively or in addition, the flared tip portion may include a resilient material such that, for example, at least a portion of the flared tip portion may flex toward the longitudinal axis when the elongate body travels through the aperture in the wall of the heart. The cannula may also include a second ring member that is spaced from the first ring member and which includes a fabric that is adapted to be sutured to the wall of the heart. The fabric may alternatively or additionally be adapted for tissue ingrowth therethrough.

**[0007]** In another embodiment, a method of implanting a cannula into a chamber of a heart includes moving the cannula in a first direction through an aperture into the chamber. The chamber receives a flared tip portion of the cannula extending from a flat portion thereof. A position of the cannula within the chamber is established by contacting a wall of the chamber with a ring member extending around a longitudinal axis of the cannula.

**[0008]** In yet another embodiment, a heart assist system for coupling into fluid communication with a chamber of a heart includes a blood pump including an inlet and a cannula with one or more of the features, alone or in combination, generally described above for the respective cannulae of the different embodiments.

### **Brief Description of the Drawings**

**[0009]** Various additional features and aspects will become readily apparent to those of ordinary skill in the art from the following description of illustrative embodiments of the invention and from the drawings in which:

**[0010]** FIG. 1 is a partial cross-sectional view of a heart in a human body, depicting an exemplary use of a cannula as part of a heart assist system;

**[0011]** FIG. 2A is a perspective view of an exemplary cannula prior to implantation in a human heart;

**[0012]** FIG. 2B is a perspective view of the cannula of FIG. 2A depicting a subsequent step in the implantation thereof;

- [0013]** FIG. 3 is an elevational cross-sectional view of an embodiment of a cannula;
- [0014]** FIG. 4A is an enlarged cross-sectional view of an exemplary embodiment of a cannula prior to implantation in a human heart;
- [0015]** FIG. 4B is an enlarged cross-sectional view of the cannula of FIG. 4A in a subsequent step during implantation thereof;
- [0016]** FIG. 4C is an enlarged cross-sectional view of the cannula of FIGS. 4A-4B in another subsequent step during implantation thereof;
- [0017]** FIG. 4D is an enlarged cross-sectional view of the cannula of FIGS. 4A-4C in yet another subsequent step during implantation thereof;
- [0018]** FIG. 5A is an enlarged cross-sectional view of an alternative exemplary embodiment of a cannula prior to implantation in a human heart;
- [0019]** FIG. 5B is a similar view of the embodiment of FIG. 5A in a subsequent step during implantation thereof;
- [0020]** FIG. 6A is an enlarged cross-sectional view of an alternative exemplary embodiment of a cannula during implantation in a human heart;
- [0021]** FIG. 6B is an enlarged cross-sectional view of the cannula of FIG. 6A in a subsequent step during implantation thereof;
- [0022]** FIG. 7A is an enlarged partial cross-sectional view of another alternative exemplary embodiment of a cannula prior to implantation in a human heart; and
- [0023]** FIG. 7B is a similar view of the embodiment of FIG. 7A in a subsequent step during implantation thereof.

### **Detailed Description**

**[0024]** With reference to the figures and, more particularly to FIGS. 1 and 2A-2B, a cannula 10 is adapted for implantation into a chamber of a heart 14. Such chamber may, for example, be one on the left side of the heart 14 such as a left atrium 14a or a left ventricle 14b. Implantation may be carried out, for example, by inserting a portion of the cannula 10 into the chamber 14a through an incision or aperture 13 communicating an interior of the chamber 14a with an exterior thereof. Once implanted, the cannula 10 may permit flow of blood between the chamber 14a and other locations of the human body 11 or devices such as a heart-assist device or blood pump 15. For example, the blood pump 15 may be of the type disclosed in U.S. Patent No. 6,116,862, the disclosure of

which is fully incorporated by reference herein. The cannula 10 may thus be coupled into fluid communication with the chamber 14a and further into fluid communication with an inlet 15a of the blood pump 15. Another cannula may also be connected into fluid communication with an outlet 15b of the blood pump 15 and, ultimately, to the circulatory system of the patient, as shown for example in FIG. 1. Moreover, fixation of the cannula 10 in the chamber 14a may include the application of sutures 19 or the like through or about portions of the cannula 10 and through surfaces of the heart 14.

**[0025]** With reference to FIG. 3, the cannula 10 includes an elongate body 16 having longitudinally opposed first and second ends 18, 20 and a lumen 22 extending about a longitudinal axis 24 of the elongate body 16. The first and second ends 18, 20 define openings 26a, 26b into the lumen 22, such that blood may flow along the lumen 22 between the first and second ends 18, 20.

**[0026]** In one aspect of this embodiment, some or all of the elongate body 16 of the cannula 10 is made of a biocompatible yet flexible or semi-flexible material such as, and without limitation, silicone or reinforced silicone. Semi-flexible materials may be desirable, for example, where the elongate body 16 includes no rigid components e.g., metals, such that the second end 20 may remain open and thereby available for unrestricted flow of blood therethrough.

**[0027]** The cannula 10 includes a flared tip portion 30 disposed about the elongate body 16 to facilitate insertion of the cannula 10 into the chamber 14a of the heart 14. The flared tip portion 30 extends from the second end 20 of the elongate body 16 of the cannula 10 in a direction toward the first end 18 and flares radially outward from the longitudinal axis 24 and in such direction.

**[0028]** In the exemplary embodiment of FIG. 3, the flared tip portion 30 further extends from a flat portion 32 of the second end 20. Alternatively, however, the flared tip portion 30 may extend from other non-flat portions of the elongate body 16. Similarly, while the embodiment of FIG. 3 depicts the flared tip portion 30 extending from a flat portion 32 that is generally perpendicular or normal to the longitudinal axis 24, it is contemplated that the flared tip portion 30 may alternatively extend from a flat portion that is not generally perpendicular or normal to the longitudinal axis 24. For example, and without limitation, the flared tip portion 30 may extend from a flat portion that defines an acute or obtuse included angle with the longitudinal axis 24.

**[0029]** A flat portion, as described herein, may further be part of a wall 17 of the elongate body 16, as is the case with the exemplary flat portion 32 of FIG. 3, or alternatively be part of any other portion of the second end 20 of the elongate body 16 of the cannula 10. Likewise, the flat portion may be defined by any plane defined by the opening 26b on the second end 20 of the elongate body 16.

**[0030]** The flared tip portion 30 flares radially outward from longitudinal axis 24 and in a direction toward the first end 18. In the illustrative embodiment of FIG. 3, the flared tip portion 30 further flares out radially from the flat portion 32 of the second end 20 although the flared tip portion 30 may alternatively flare out radially from other non-flat portions thereof or from any alternative flat portions as generally described above.

**[0031]** With continued reference to FIG. 3, a ring member 36 is disposed on the elongate body 16 and extends about the longitudinal axis 24. The ring member 36 is spaced from the flared tip portion 30 to provide a suitable length of the cannula 10 to be implanted in the chamber 14a of the heart 14. More particularly, once the cannula 10 is inserted in the chamber 14a, contact between the ring member 36 and a wall 40 of the heart 14 provides an implant position of the cannula 10 along the longitudinal axis 24 and relative to the wall 40 of the heart 14, thereby defining the length of the portion of cannula 10 within the chamber 14a.

**[0032]** In one aspect of the embodiment of FIG. 3, the construction of the flared tip portion 30 provides a smooth, non-stepped transition between the second end 20 of the elongate body 16 of the cannula 10 and the ring member 36.

**[0033]** With reference to FIGS. 4A, 4B, 4C, 4D, 5A, 5B, 6A, 6B, 7A and 7B, several exemplary embodiments applying one or more of the principles described with reference to the general embodiment of FIG. 3 are shown and will be described in turn. With reference to FIGS. 4A-4D, in which like reference numerals refer to like features in FIG. 3, an exemplary embodiment of a cannula 70 includes a flexible flared tip portion 72, a ring member 74, and a gap 75 therebetween. The flexible flared tip portion 72 is defined by a wall 76 including a barbed surface 78 and extends from a second end 79 of the cannula 70 to end at an edge or surface 81. In an open position, as depicted in FIG. 4A, the edge or surface 81 is a generally annular structure that is larger in diameter

than the elongate body 70a of the cannula 70 and larger as well, in diameter, than the gap 75.

**[0034]** With continued reference to FIGS. 4A-4D, the flexible flared tip portion 72 is adapted to flex toward the longitudinal axis 70b as the cannula 70 and, more particularly, the flexible flared tip portion 72, travels through the aperture 13 into the chamber 14a. To that end, the flexible flared tip portion 72 is made of a biocompatible flexible, resilient material such as, and without limitation, silicone. Moreover, in the exemplary embodiment of FIGS. 4A-4D, flexibility of the flexible flared tip portion 72 is facilitated by including a wall 76 of varying thickness. More specifically, the thickness of the wall 76 is greater in regions near the second end 79 than in regions proximate the edge or surface 81.

**[0035]** Alternatively, flexibility of the flexible flared tip portion 72 can be controlled or influenced in other ways. For example, and without limitation, the flexible flared tip portion 72 may include flexible polymer structures, flexible metallic structures such as NiTi, rigid structures such as structures formed with titanium or titanium alloys, or struts (not shown).

**[0036]** With continued reference to FIGS. 4A-4D, the cannula 70 further includes a ring member 74 spaced from the flexible flared tip portion 72. The ring member 74 is made of a resilient material to facilitate travel thereof through the aperture 13 into or out of the chamber 14a. To this end, the ring member 74 may include, without limitation, flexible, resilient, biocompatible materials such as silicone.

**[0037]** As explained above, the cannula 70 is designed to be implanted in a chamber 14a of the heart 14. To that end, the exemplary cannula 70 is inserted through the aperture 13 in the wall 40 of the heart 14. During insertion, the wall 76 of the flexible flared tip portion 72 is pushed radially inward i.e., toward the longitudinal axis 70b of the cannula 70, as depicted in FIG. 4B, by portions of the wall 40 of the heart 14 around the aperture 13. The flexible flared tip portion 72 flares back to its original shape, as depicted in FIGS. 4C-4D, once the flexible flared tip portion 72 passes completely through the wall 40 and is completely received within the chamber 14a.

**[0038]** With reference to FIGS. 4C-4D, implantation of the cannula 70 may include, in addition to insertion of the flexible flared tip portion 72, insertion of the ring member 74 through the aperture 13 and subsequent retrieval thereof

(i.e., in an opposite direction away from the chamber 14a). Retrieval or removal of the ring member 74 may carry with it loose tissue material lying on surfaces defining the aperture 13, produced as a result of the procedure that created the aperture 13, and gathered by the previous passage of the flexible flared tip portion 72 through the aperture 13.

**[0039]** The final position of the cannula 70 within the chamber 14a, best appreciated in FIG. 4D, is therefore determined by contact between the ring member 74 and the outer surface 80 of the wall 40 of the heart 14. Moreover, contact between the edge or surface 81 of the flexible flared tip portion 72 and an inner surface 82 of the wall 40 further establishes the final position of the cannula 70 within the chamber 14a. In another aspect of this embodiment, the final position of the cannula 70 within the chamber 14a can be further secured, for example, and without limitation, via a purse string suture 19a applied to portions of the wall 40 surrounding the gap 75 between the flexible flared tip portion 72 and the ring member 74.

**[0040]** The flexible nature of the flexible flared tip portion 72 permits sealing of the aperture 13 from within the chamber 14a even in cases where the inner surface 82 surrounding the aperture 13 is uneven and/or in cases where the cannula 70 is not orthogonally oriented with respect to the inner surface 82. More particularly, the wall 76 defining the flexible flared tip portion 72 compensates for any unevenness or non-orthogonal orientation of the cannula 70 by flexing to different degrees along the circumference defined by the edge or surface 81.

**[0041]** In another aspect of the embodiment of FIGS. 4A-4D, overgrowth of tissue surrounding the aperture 13 into the lumen 70c of the cannula 70 is minimized. More particularly, the shape of the wall 76 of the flexible flared tip portion 72 provides a relatively long path between the aperture 13 and the second end 79 such that tissue from portions of the wall 40 defining the aperture 13 is less likely to reach the second end 79 of the cannula 70.

**[0042]** With reference to FIGS. 5A-5B, in which like reference numerals refer to like features in FIG. 3, an alternate embodiment of a cannula 90 includes a rigid flared tip portion 92, a ring member 94 and a gap 96 therebetween. The rigid flared tip portion 92 includes flaring walls 98 extending from the second end 99 of the cannula 90 and ending, in cross-section, at a juncture 93 with the gap 96.



**[0043]** In one aspect of this illustrative embodiment, the rigid flared tip portion 92 is made of a suitably chosen rigid, biocompatible material, such as, and without limitation, a suitably chosen metal. For example, and without limitation, the rigid flared tip portion 92 may be made of titanium or an alloy thereof. Similarly, the rigid flared tip portion 92, by including a non-porous surface, prevents or minimizes overgrowth of tissue thereon, thereby avoiding or minimizing restriction to the flow of blood through the second end 99.

**[0044]** The rigid flared tip portion 92 is suitably coupled to a main portion 100 of the cannula 90 to thereby define an elongate body 111 thereof. To this end, coupling components are suitably chosen and may include, without limitation, adhesives, mechanical fasteners, fittings, integral formation, and the like. In the exemplary embodiment of FIGS. 5A-5B, the rigid flared tip portion 92 includes a cylindrical portion 102 embedded within a segment of the main portion 100 of the elongate body 111 of the cannula 90.

**[0045]** The ring member 94 is disposed around the elongate body 111 and is spaced from the rigid flared tip portion 92. In addition to establishing a final position of the cannula 90 within the chamber 14a, the ring member 94 permits coupling of the cannula 90 to the wall 40 of the heart 14. To this end, the ring member 94 includes a fabric 104 adapted to be surgically sutured to the wall 40. The fabric 104 may alternatively or additionally be adapted for tissue ingrowth therethrough, thereby permitting locking engagement of the ring member 94 with tissue positioned proximate ring member 94. For example, and without limitation, the ring member 94 may include a polyester-based fabric, such as one commercially available under the tradename Dacron®, covering a structural portion 106 of the ring member 94.

**[0046]** With continued reference to FIGS. 5A-5B, the fabric 104 may be coupled to the structural portion 106 of the ring member 94 by any suitably chosen components and/or methods. For example, the fabric 104 may be adhesively bonded to an outer surface of the structural portion 106 of the ring member 94. Alternatively, the fabric 104 may be attached via grooves 107 or the like on the outer surface of the structural portion 106 and corresponding ties (not shown) extending from the fabric 104.

**[0047]** Persons of ordinary skill in the art will appreciate that, although the exemplary embodiment herein described includes a fabric 104 substantially defining a volume of the ring member 94, the ring member 94 may alternatively

include other rigid or semi-rigid substructures (not shown) at least partially defining the volume of ring member 94 and covered by fabric 104.

**[0048]** As mentioned above, the cannula 90 includes a gap 96 disposed between the rigid flared tip portion 92 and the ring member 94. In the exemplary embodiment of FIGS. 5A-5B, the gap 96 includes a fabric 108 similar in structure, composition, coupling to an underlying surface, and function, to the fabric 104 of the ring member 94, such that the fabric 108 provides a suturing surface to which portions of the heart 14, such as wall 40, can be coupled. Moreover, the fabric 108 may alternatively or additionally provide a surface into which tissue of the wall 40 of the heart 14 can grow, further securing the position of the implanted cannula 90 within the chamber 14a.

**[0049]** Similarly to the procedure described in regard to the embodiments of FIGS. 4A-4D, the cannula 90 is inserted through the aperture 13 in the wall 40 of the heart 14 to establish fluid communication with the chamber 14a. To this end, the cannula 90 may be inserted until the ring member 94 contacts the outer surface 80 of the wall 40, thereby establishing a final position for the cannula 90 within the chamber 14a.

**[0050]** Once the final position of the cannula 90 is reached i.e., by contact between the ring member 94 and the wall 40, the cannula 90 may be secured by any conventional methods and/or components known to those of ordinary skill in the art. Thus, the cannula 90 can be coupled to the wall 40 of the heart 14, for example, via conventional stitches 19b (FIG. 5B) engaging either or both of the fabrics 104, 108, respectively, of the ring member 94 and gap 96.

**[0051]** With reference to FIGS. 6A-6B, in which like reference numerals refer to like features in FIG. 3, an alternate exemplary embodiment of a cannula 120 includes a barbed flared tip portion 122, a ring member 124 and a gap 126 therebetween. The barbed flared tip portion 122 includes flaring walls 128 extending from the second end 129 of the cannula 120 and ending at a surface 130 defining a juncture with the gap 126 and extending around an outer surface 132a of the elongate body 133 of the cannula 120.

**[0052]** Similarly to the embodiment of the cannula 90 (FIGS. 5A-5B), the barbed flared tip portion 122 is made of a suitably chosen rigid, biocompatible material, such as, and without limitation, titanium or an alloy thereof. Similarly, the barbed flared tip portion 122, by including a non-porous surface, prevents or

minimizes overgrowth of tissue thereon, thereby avoiding or minimizing restriction to the flow of blood through the second end 129.

**[0053]** The barbed flared tip portion 122 is suitably coupled to a main portion 131 of the cannula 120 to thereby define the elongate body 133 thereof. To this end, coupling components are suitably chosen and may include, without limitation, adhesives, mechanical fasteners, fittings, integral formation, and the like. In the exemplary embodiment of FIGS. 6A-6B, the barbed flared tip portion 122 includes a cylindrical portion 132 embedded within a segment of the main portion 131 of the elongate body 133.

**[0054]** The ring member 124 is disposed around the elongate body 133 and is spaced from the barbed flared tip portion 122. Similarly to the embodiment of the cannula 90 (FIGS. 5A-5B), in addition to establishing a final position of the cannula 120 within the chamber 14a, the ring member 124 permits coupling of the cannula 120 to the wall 40 of the heart 14. To this end, the ring member 124 includes a fabric 134 adapted to be surgically sutured to the wall 40. The fabric 134 may alternatively or additionally be adapted for tissue ingrowth therethrough, thereby permitting locking engagement of the ring member 124 with tissue positioned proximate ring member 124. For example, and without limitation, the ring member 124 may include a polyester-based fabric, such as one commercially available under the tradename Dacron®, covering a structural portion 136 of the ring member 124.

**[0055]** In this exemplary embodiment, the fabric 134 is coupled to the structural portion 136 of the ring member 124 by any suitably chosen components and/or methods. For example, the fabric 134 may be adhesively bonded to an outer surface of the structural portion 136 of the ring member 124. Alternatively, the fabric 134 may be attached via grooves 137 or the like on the outer surface of the structural portion 136 and corresponding ties (not shown) extending from the fabric 134.

**[0056]** Persons of ordinary skill in the art will appreciate that, although the exemplary embodiment herein described includes a fabric 134 substantially defining a volume of the ring member 124, the ring member 124 may alternatively include other rigid or semi-rigid substructures (not shown) at least partially defining the volume of ring member 124 and covered by fabric 134.

**[0057]** Similarly to the procedure described in regard to the embodiments of FIGS. 4A-4B and 5A-5B, the cannula 120 of FIGS. 6A-6B is inserted through

the aperture 13 in the wall 40 of the heart 14 to establish fluid communication with the chamber 14a. To this end, the cannula 120 may be inserted until the ring member 124 contacts the outer surface 80 of the wall 40, thereby establishing a final position for the cannula 120 within the chamber 14a.

Moreover, the surface 130 provides sealing of the aperture 13 from within the chamber 14a by being positioned against the inner surface 82 of the wall 40.

**[0058]** With continued reference to FIGS. 6A-6B, once the final position of the cannula 120 is reached i.e., by contact between the ring member 124 and wall 40, the cannula 120 may be secured by any conventional methods and/or components known to those of ordinary skill in the art. Thus, the cannula 120 can be coupled to the wall 40 of the heart 14, for example, via conventional stitches 19b engaging the fabric 134 of the ring member 124.

**[0059]** With reference to FIGS. 7A-7B, in which like reference numerals refer to like features in FIG. 3, an alternate exemplary embodiment of a cannula 150 includes a rigid flared tip portion 152, a first ring member 154 spaced from the rigid flared tip portion 152, a second ring member 156 adjacent the rigid flared tip portion 152, and a gap 158 between the first and second ring members 154, 156.

**[0060]** The rigid flared tip portion 152 includes flaring walls 160 extending from the second end 159 of the cannula 150 and ending at a juncture 162 with a tubular section 164 of the elongate body 168. In this exemplary embodiment, the rigid flared tip portion 152 and the tubular section 164 have the same diameter at the juncture 162. Persons of ordinary skill in the art will, however, readily appreciate that the respective diameters of the rigid flared tip portion 152 and tubular section 164 at the juncture 162 may, alternatively, differ with respect to one another.

**[0061]** In one aspect of this illustrative embodiment, the rigid flared tip portion 152 is made of a suitably chosen rigid, biocompatible material, such as, and without limitation, a suitably chosen metal. For example, and without limitation, the rigid flared tip portion 152 may be made of titanium or an alloy thereof. Similarly, the rigid flared tip portion 152, by including a non-porous surface, prevents or minimizes overgrowth of tissue thereon, thereby avoiding or minimizing restriction to the flow of blood through the second end 159.

**[0062]** The rigid flared tip portion 152 is suitably coupled to a main portion 161 of the cannula 150 to thereby define the elongate body 168 thereof.

To this end, coupling components are suitably chosen and may include, without limitation, adhesives, mechanical fasteners, fittings, integral formation, and the like. In the exemplary embodiment of FIGS. 7A-7B, the rigid flared tip portion 152 includes a cylindrical portion 163 embedded within a segment of the main portion 161 of the elongate body 168 of the cannula 150.

**[0063]** With continued reference to FIGS. 7A-7B, the cannula 150 includes a first ring member 154 spaced from the rigid flared tip portion 152. The first ring member 154 is made of a resilient material so as to facilitate travel thereof into or out of the chamber 14a. To this end, the first ring member 154 may include, without limitation, flexible, resilient, biocompatible materials such as silicone.

**[0064]** As mentioned above, the cannula 150 includes a second ring member 156. The second ring member 156 is disposed around the tubular section 164 of the elongate body 168 and lies adjacent the rigid flared tip portion 152. The second ring member 156 permits coupling of the cannula 150 to the inner surface 82 of the wall 40 of the heart 14. To this end, the second ring member 156 includes a fabric 165 adapted to be surgically sutured to the wall 40. The fabric 165 may alternatively or additionally be adapted for tissue ingrowth therethrough, thereby permitting locking engagement of the ring member 156 with tissue positioned proximate ring member 156. For example, and without limitation, the second ring member 156 may include a polyester-based fabric, such as one commercially available under the tradename Dacron®, covering a structural portion 166 of the second ring member 156.

**[0065]** Moreover, the porous structure of the second ring member 156, which is provided by the fabric 165, may alternatively or additionally provide a surface into which tissue within the chamber 14a of the heart 14 can grow, thereby providing long-term fixation of the cannula 150 in the chamber 14a. In another aspect of this embodiment, by permitting tissue ingrowth, the second ring member 156 further seals the aperture 13 in the wall 40 of the heart 14.

**[0066]** In the exemplary embodiment of FIGS. 7A-7B, the fabric 165 is coupled to the structural portion 166 of the second ring member 156 by any suitably chosen components and/or methods. For example, the fabric 165 may be adhesively bonded to an outer surface of the structural portion 166 of the second ring member 156. Alternatively, the fabric 165 may be attached via

grooves 167 or the like on the outer surface of the structural portion 166 and corresponding ties (not shown) extending from the fabric 165.

**[0067]** Persons of ordinary skill in the art will appreciate that, although the exemplary embodiment herein described includes a fabric 165 substantially defining a volume of the second ring member 156, the second ring member 156 may alternatively include other rigid or semi-rigid substructures (not shown) at least partially defining the volume of second ring member 156 and covered by fabric 165.

**[0068]** Similarly to the procedure described in regard to the embodiments of FIGS. 4A-4D, 5A-5B, and 6A-6B, the cannula 150 of FIGS. 7A-7B is inserted through the aperture 13 in the wall 40 of the heart 14 to establish fluid communication with the chamber 14a. To this end, the cannula 150 may be inserted until the first and second ring members 154, 156 complete passage through the aperture 13 and lie within the chamber 14a.

**[0069]** With continued reference to FIGS. 7A-7B, implantation of the cannula 150 within the chamber 14a may include, in addition to movement of the cannula 150 in a first direction toward the heart 14 and subsequent insertion of the rigid flared tip portion 152 and first and second ring members 154, 156 into the chamber 14a, subsequent removal of the first ring member 154 from the chamber 14a (i.e., in a second direction opposite the first direction). Retrieval of the first ring member 154 drags therewith loose tissue material lying on surfaces defining the aperture 13, and produced as a result of the procedure that previously produced the aperture 13.

**[0070]** The final position of the cannula 150 within the chamber 14a is therefore established by contact between the first ring member 154 and the outer surface 80 of the wall 40 of the heart 14. Moreover, contact between the second ring member 156 and the inner surface 82 of the wall 40 further establishes the final position of the cannula 150 within the chamber 14a. In another aspect of this embodiment, the final position of the cannula 150 within the chamber 14a can be further secured, for example, and without limitation, via a purse string suture 19a (FIG. 7B) applied to portions of the wall 40 of the heart 14 surrounding the gap 158 between the first and second ring members 154, 156.

**[0071]** While the exemplary embodiments of FIGS. 4A-4B, 5A-5B, 6A-6B, and 7A-7B have been described as outlined above, it is contemplated that any

of the exemplary cannulae 70, 90, 120, 150 may incorporate aspects described in regard to any of the other embodiments described herein. For example, and without limitation, either of the cannulae 70, 90, 120 (respectively FIGS. 4A-4D, 5A-5B, and 6A-6B) may further include a second ring member similar to the second ring member 156 of the exemplary cannula 150 of FIGS. 7A-7B.

**[0072]** Similarly, while the above exemplary embodiments depict generally round ring members, persons of ordinary skill in the art will readily appreciate that any of the ring members can take on any other suitably chosen shape. A ring member of any embodiment may hence take on any regular or irregular shape, so long as the chosen shape is configured to permit the ring member or members of an embodiment to carry out the functions described above.

**[0073]** While the present invention has been illustrated by a description of various preferred embodiments and while these embodiments have been described in some detail, it is not the intention of the Applicant to restrict or in any way limit the scope of the appended claims to such detail. Additional advantages and modifications will readily appear to those skilled in the art. The various features of the invention may be used alone or in any combination depending on the needs and preferences of the user. This has been a description of the present invention, along with the preferred methods of practicing the present invention as currently known. However, the invention itself should only be defined by the appended claims. What is claimed is:

1. A cannula for implantation into a chamber of a heart comprising:  
an elongate body including a lumen extending along a longitudinal axis, a first end and a second end, said first and second ends defining openings into said lumen, said second end including a flat portion;  
a flared tip portion on said elongate body and extending from said flat portion of said second end in a direction toward said first end, and flaring radially outward from said longitudinal axis and in said direction; and  
a first ring member on said elongate body and extending around said longitudinal axis, said first ring member being spaced from said flared tip portion and being adapted for retaining said elongate body in a position relative to a wall of the chamber of the heart.
2. The cannula of claim 1, wherein said first ring member comprises a fabric adapted to be sutured to the wall of the chamber of the heart.
3. The cannula of claim 1, wherein said first ring member comprises a fabric adapted for tissue ingrowth therethrough.
4. The cannula of claim 3, wherein said fabric further comprises a polyester-based material.
5. The cannula of claim 1, wherein said flared tip portion comprises titanium.
6. The cannula of claim 1, wherein said flared tip portion comprises a resilient material.
7. The cannula of claim 6, wherein said resilient material further comprises silicone.
8. The cannula of claim 6, wherein said flared tip portion is configured to flex toward said longitudinal axis when said elongate body travels through an aperture in the wall of the chamber of the heart.



9. The cannula of claim 1, wherein said first ring member comprises a resilient material.
10. The cannula of claim 9, wherein said resilient material further comprises silicone.
11. The cannula of claim 1, further comprising a second ring member on said elongate body and extending around said longitudinal axis, said second ring member spaced from said first ring member along said longitudinal axis.
12. The cannula of claim 11, wherein said second ring member comprises a fabric adapted to be sutured to the wall of the chamber of the heart.
13. The cannula of claim 11, wherein said second ring member comprises a fabric adapted for tissue ingrowth therethrough.
14. The cannula of claim 13, wherein said fabric further comprises a polyester-based material.
15. The cannula of claim 1, further comprising a gap between said first ring member and said flared tip portion, and a fabric positioned in said gap.
16. The cannula of claim 15, wherein said fabric is adapted to be sutured to the wall of the chamber of the heart.
17. The cannula of claim 15, wherein said fabric is adapted for tissue ingrowth therethrough.
18. The cannula of claim 17, wherein said fabric comprises a polyester-based material.

19. A heart assist system for coupling into fluid communication with a chamber of a heart comprising:
- a blood pump including an inlet;
  - an elongate body including a first end, a second end, and a lumen adapted to be coupled into fluid communication with said inlet, said lumen extending along a longitudinal axis, said first and second ends defining openings into said lumen, said second end including a flat portion;
  - a flared tip portion on said elongate body and extending from said flat portion of said second end in a direction toward said first end, and flaring radially outward from said longitudinal axis and in said direction; and
  - a ring member on said elongate body and extending around said longitudinal axis, said ring member being spaced from said flared tip portion and being adapted for retaining said elongate body in a position relative to a wall of the chamber of the heart.
20. A cannula for implantation into a chamber of a heart comprising:
- an elongate body including a lumen extending along a longitudinal axis, a first end and a second end, said first and second ends defining openings into said lumen;
  - a flared tip portion on said elongate body and extending from said second end in a direction toward said first end, and flaring radially outward from said longitudinal axis and in said direction, said flared tip portion being configured to flex toward said longitudinal axis when said elongate body travels through an aperture in a wall of the chamber of the heart; and
  - a ring member on said elongate body and extending around said longitudinal axis, said ring member being spaced from said flared tip portion and being adapted for retaining said elongate body in a position relative to the wall of the chamber of the heart.
21. The cannula of claim 20, wherein said flared tip portion comprises a resilient material.
22. The cannula of claim 21, wherein said resilient material further comprises silicone.

23. The cannula of claim 20, wherein said ring member comprises a resilient material.

24. The cannula of claim 23, wherein said resilient material further comprises silicone.

25. A heart assist system for coupling into fluid communication with a chamber of a heart comprising:

a blood pump including an inlet;

an elongate body including a first end, a second end, and a lumen adapted to be coupled into fluid communication with said inlet, said lumen extending along a longitudinal axis, said first and second ends defining openings into said lumen;

a flared tip portion on said elongate body and extending from said second end in a direction toward said first end, and flaring radially outward from said longitudinal axis and in said direction, said flared tip portion being configured to flex toward said longitudinal axis when said flared tip portion travels through an aperture in a wall of the chamber of the heart; and

a ring member on said elongate body and extending around said longitudinal axis, said ring member being spaced from said flared tip portion and being adapted for retaining said elongate body in a position relative to the wall of the chamber of the heart.

26. A cannula for implantation into a chamber of a heart comprising:

an elongate body including a lumen extending along a longitudinal axis, a first end and a second end, said first and second ends defining openings into said lumen;

a flared tip portion on said elongate body and extending from said second end in a direction toward said first end, and flaring radially outward from said longitudinal axis and in said direction, said flared tip portion including a barbed surface configured to contact tissue around an aperture in a wall of the chamber of the heart when said elongate body travels through the aperture; and

a ring member on said elongate body and extending around said longitudinal axis, said ring member being spaced from said flared tip portion and being adapted for retaining said elongate body in a position relative to the wall of the chamber of the heart.

27. The cannula of claim 26, wherein said ring member comprises a fabric adapted to be sutured to the wall of the chamber of the heart.

28. The cannula of claim 26, wherein said ring member comprises a fabric adapted for tissue ingrowth therethrough.

29. The cannula of claim 28, wherein said ring member further comprises a polyester-based material.

30. The cannula of claim 26, wherein said flared tip portion further comprises titanium.

31. The cannula of claim 30, wherein said ring member further comprises a resilient material.

32. The cannula of claim 31, wherein said resilient material further comprises silicone.

33. The cannula of claim 26, wherein said flared tip portion further comprises a resilient material.

34. The cannula of claim 33, wherein said resilient material further comprises silicone.

35. A heart assist system for coupling into fluid communication with a chamber of a heart comprising:
- a blood pump including an inlet;
  - an elongate body including a first end, a second end, and a lumen adapted to be coupled into fluid communication with said inlet, said lumen extending along a longitudinal axis, said first and second ends defining openings into said lumen;
  - a flared tip portion on said elongate body and extending from said second end in a direction toward said first end, and flaring radially outward from said longitudinal axis and in said direction, said flared tip portion including a barbed surface configured to contact tissue around an aperture in a wall of the chamber of the heart when said flared tip portion travels through the aperture; and
  - a ring member on said elongate body and extending around said longitudinal axis, said ring member being spaced from said flared tip portion and being adapted for retaining said elongate body in a position relative to the wall of the chamber of the heart.
36. A cannula for implantation into a chamber of a heart comprising:
- an elongate body including a lumen extending along a longitudinal axis, a first end and a second end, said first and second ends defining openings into said lumen;
  - a metallic flared tip portion on said elongate body and extending from said second end in a direction toward said first end, and flaring radially outward from said longitudinal axis and in said direction; and
  - a first ring member on said elongate body and extending around said longitudinal axis, said first ring member being spaced from said metallic flared tip portion and adapted for retaining said elongate body in a position relative to a wall of the chamber of the heart.
37. The cannula of claim 36, further comprising a second ring member on said elongate body and extending around said longitudinal axis, said second ring member spaced from said first ring member along said longitudinal axis.

38. The cannula of claim 37, wherein said second ring member comprises a fabric adapted to be sutured to the wall of the chamber of the heart.
39. The cannula of claim 37, wherein said second ring member comprises a fabric adapted for tissue ingrowth therethrough.
40. The cannula of claim 39, wherein said fabric further comprises a polyester-based material.
41. The cannula of claim 36, further comprising a gap defined between said first ring member and said metallic flared tip portion, and a fabric positioned in said gap, said fabric adapted to be sutured to the wall of the chamber of the heart.
42. The cannula of claim 36, further comprising a gap defined between said first ring member and said metallic flared tip portion, and a fabric positioned in said gap, said fabric adapted for tissue ingrowth therethrough.
43. The cannula of claim 42, wherein said fabric further comprises a polyester-based material.
44. The cannula of claim 36, wherein said metallic flared tip portion comprises titanium.
45. The cannula of claim 36, wherein said first ring member comprises a fabric adapted to be sutured to the wall of the chamber of the heart.
46. The cannula of claim 36, wherein said first ring member comprises a fabric adapted for tissue ingrowth therethrough.
47. The cannula of claim 46, wherein said fabric further comprises a polyester-based material.

48. The cannula of claim 36, wherein said first ring member comprises a resilient material.
49. The cannula of claim 48, wherein said resilient material further comprises silicone.
50. A heart assist system for coupling into fluid communication with a chamber of a heart comprising:  
a blood pump including an inlet;  
an elongate body including a first end, a second end, and a lumen adapted to be coupled into fluid communication with said inlet, said lumen extending along a longitudinal axis, said first and second ends defining openings into said lumen;  
a metallic flared tip portion on said elongate body and extending from said second end in a direction toward said first end, and flaring radially outward from said longitudinal axis and in said direction; and  
a ring member on said elongate body and extending around said longitudinal axis, said ring member being spaced from said metallic flared tip portion and adapted for retaining said elongate body in a position relative to a wall of the chamber of the heart.
51. A method of implanting a cannula having a longitudinal axis into a chamber of a heart, the chamber of the heart having a wall and an aperture through the wall, the method comprising:  
moving the cannula in a first direction through the aperture;  
receiving a flared tip portion of the cannula within the chamber of the heart, the flared tip portion extending from a flat portion on an end of the cannula; and  
establishing a position of the cannula within the chamber of the heart and along the longitudinal axis by contacting the wall of the chamber of the heart with a ring member extending around the longitudinal axis.
52. The method of claim 51, further comprising moving the cannula in a second direction opposite the first direction until the ring member contacts an outer surface on the wall of the chamber of the heart.

53. The method of claim 51, further comprising moving the cannula in a second direction opposite the first direction until a second ring member contacts an inner surface of the wall of the chamber of the heart.

54. The method of claim 51, further comprising flexing the flared tip portion toward the longitudinal axis as the cannula travels through the aperture.

55. The method of claim 51, further comprising coupling the ring member to the wall of the chamber of the heart.

56. The method of claim 55, wherein the coupling the ring member further comprises suturing the ring member to the wall of the chamber of the heart.

57. The method of claim 51, further comprising interlocking the ring member with tissue positioned proximate the ring member.

58. The method of claim 51, further comprising coupling a gap defined between the ring member and the flared tip portion to the wall of the chamber of the heart.

59. The method of claim 58, wherein the coupling the gap further comprises suturing the gap to the wall of the chamber of the heart.

60. The method of claim 51, further comprising interlocking a gap defined between the ring member and the flared tip portion with tissue positioned proximate the gap.



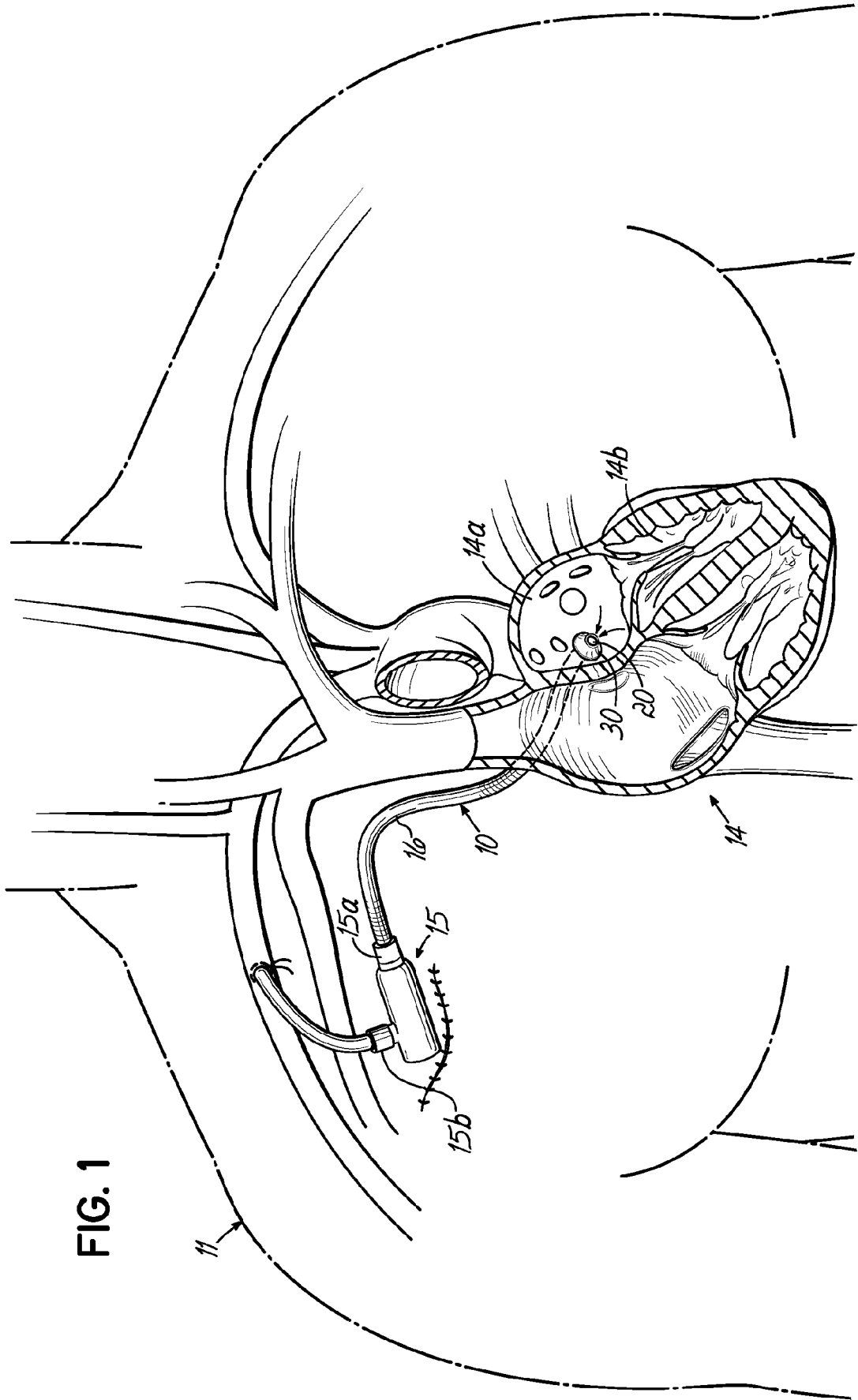
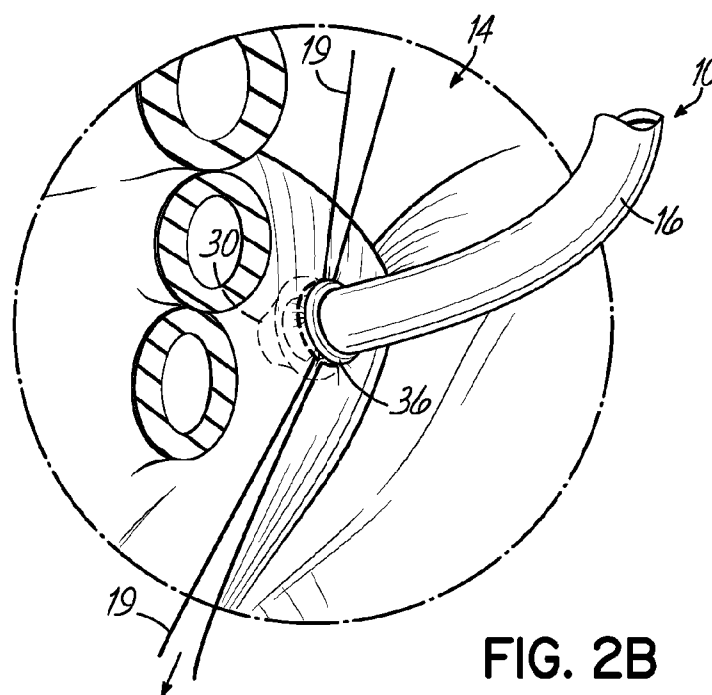
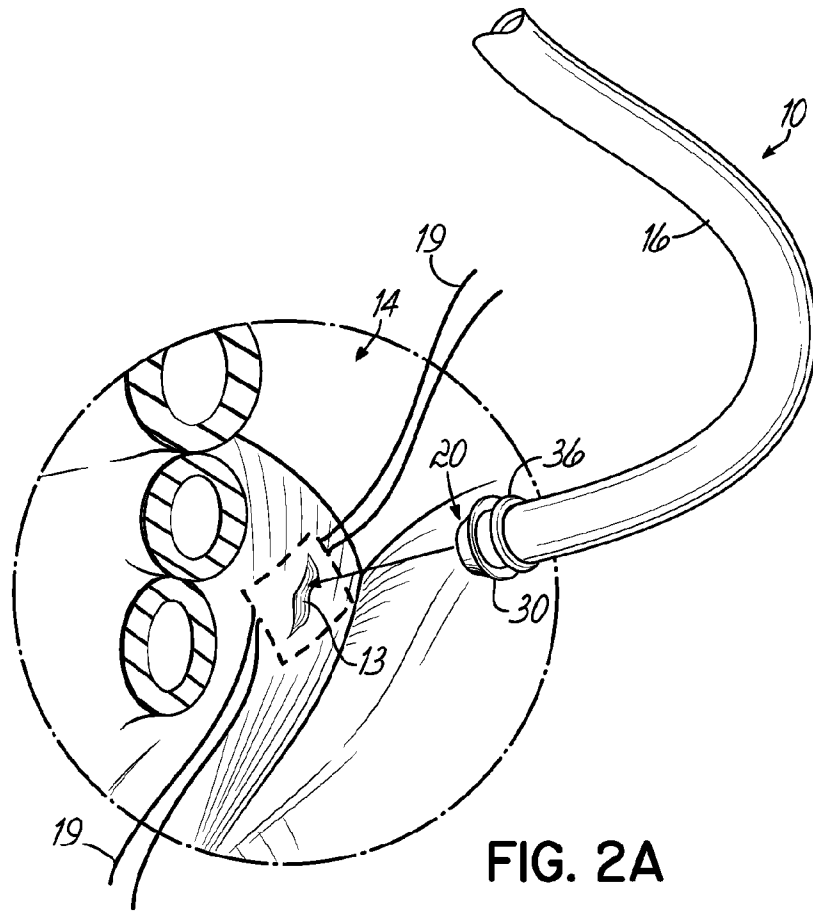

FIG. 1

2/8



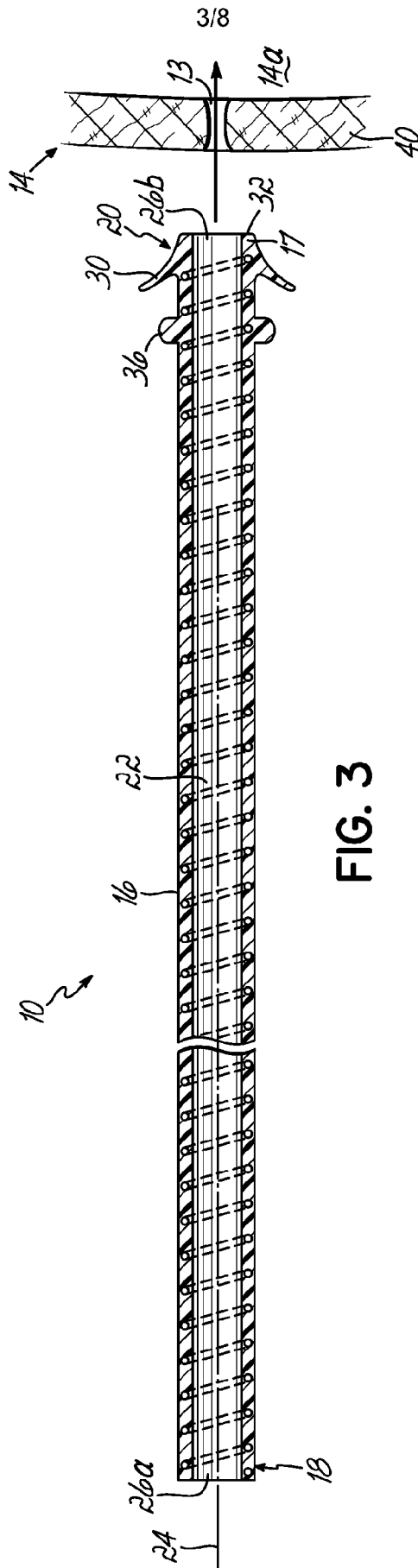

FIG. 3

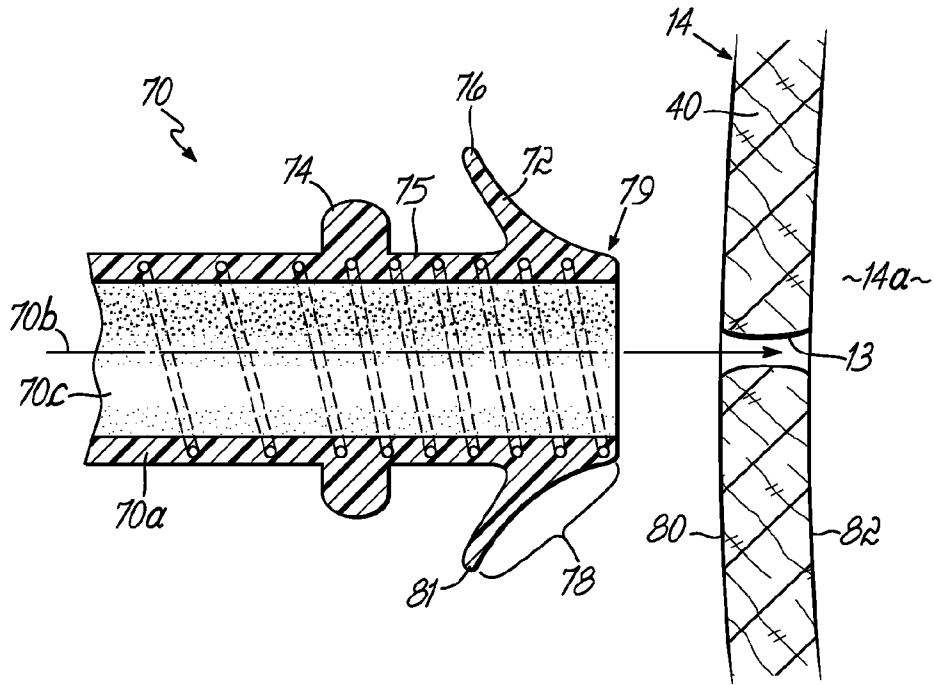

FIG. 4A

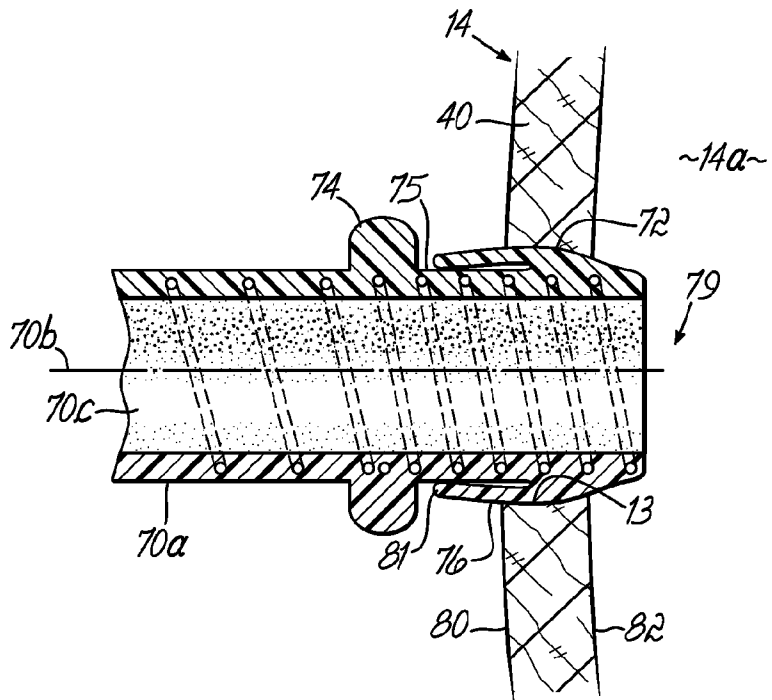

FIG. 4B

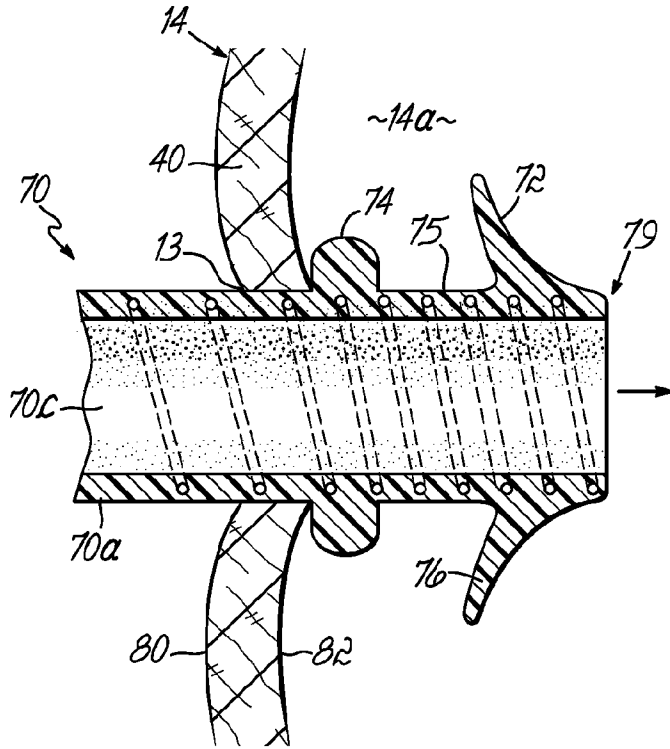

FIG. 4C

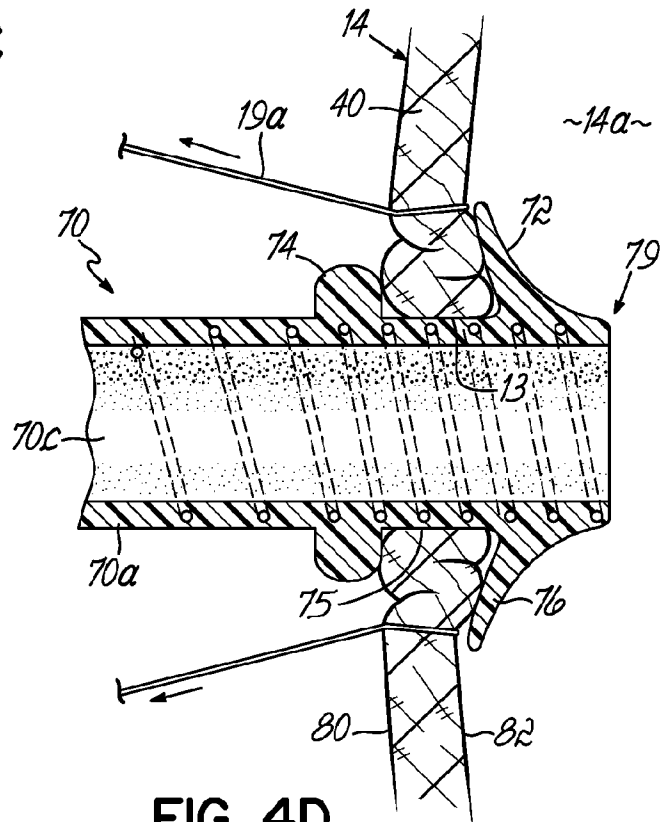

FIG. 4D

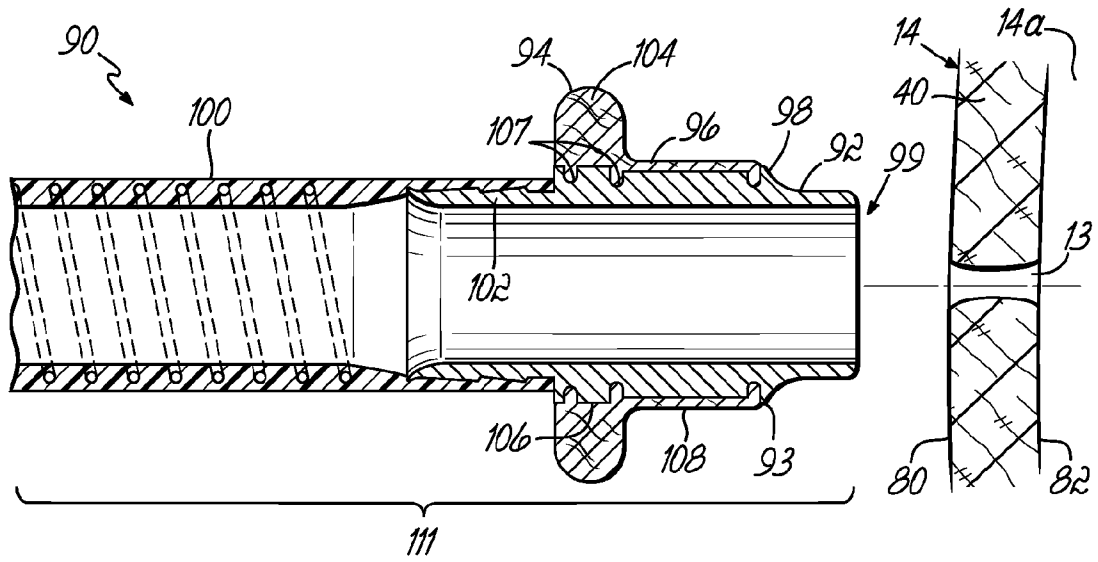

FIG. 5A

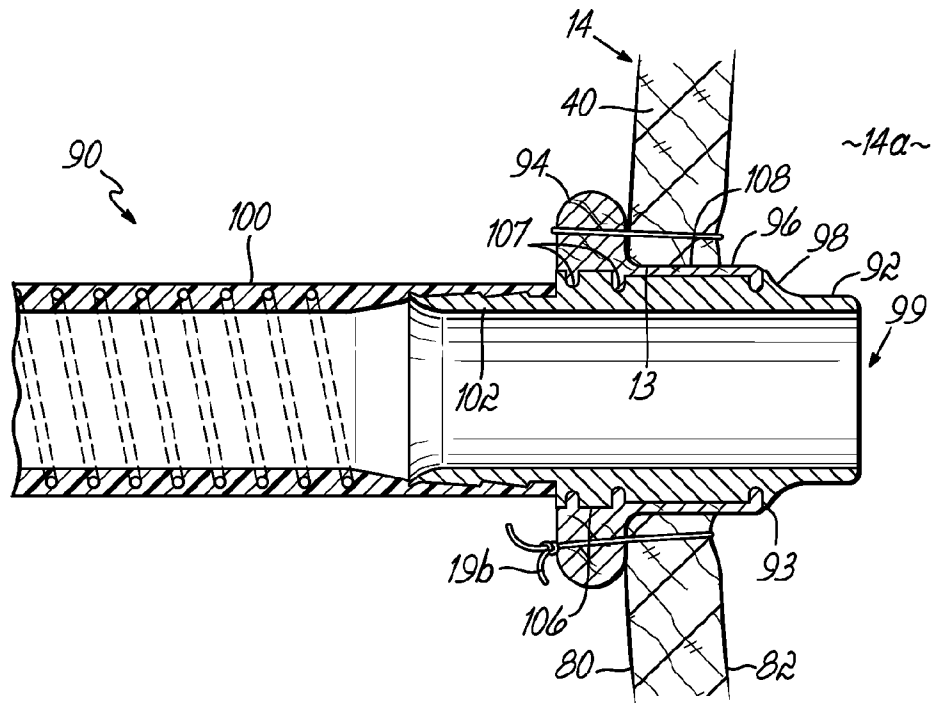

FIG. 5B

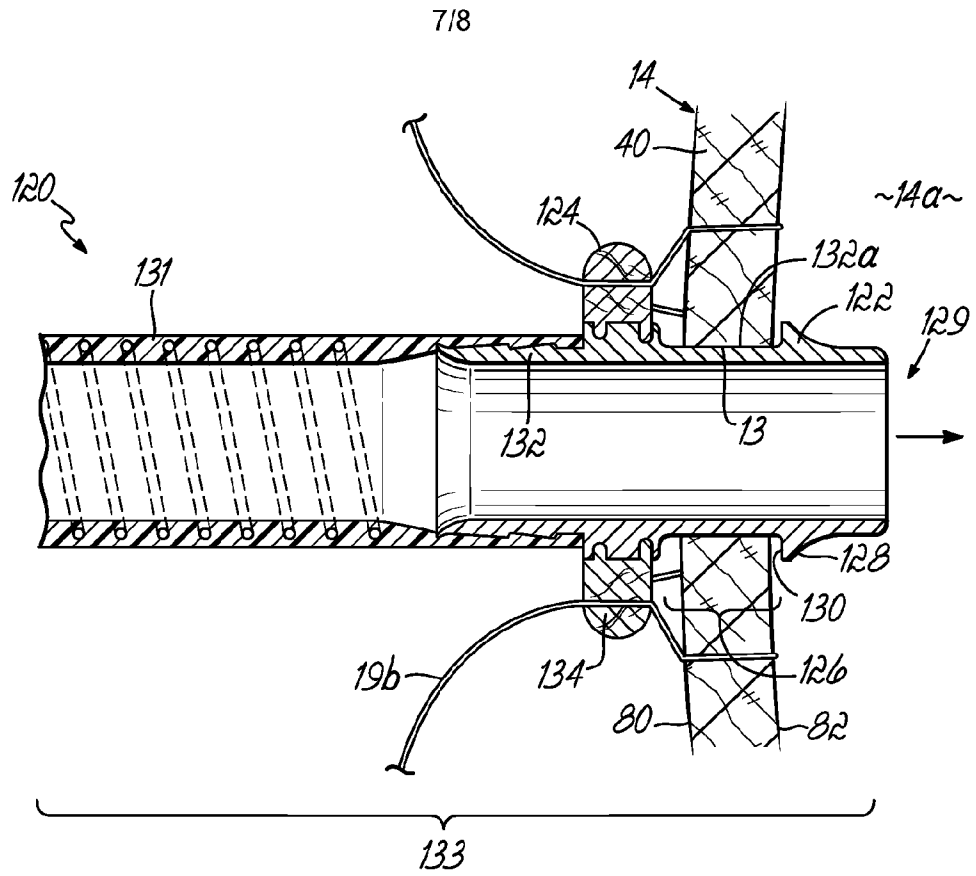

FIG. 6A

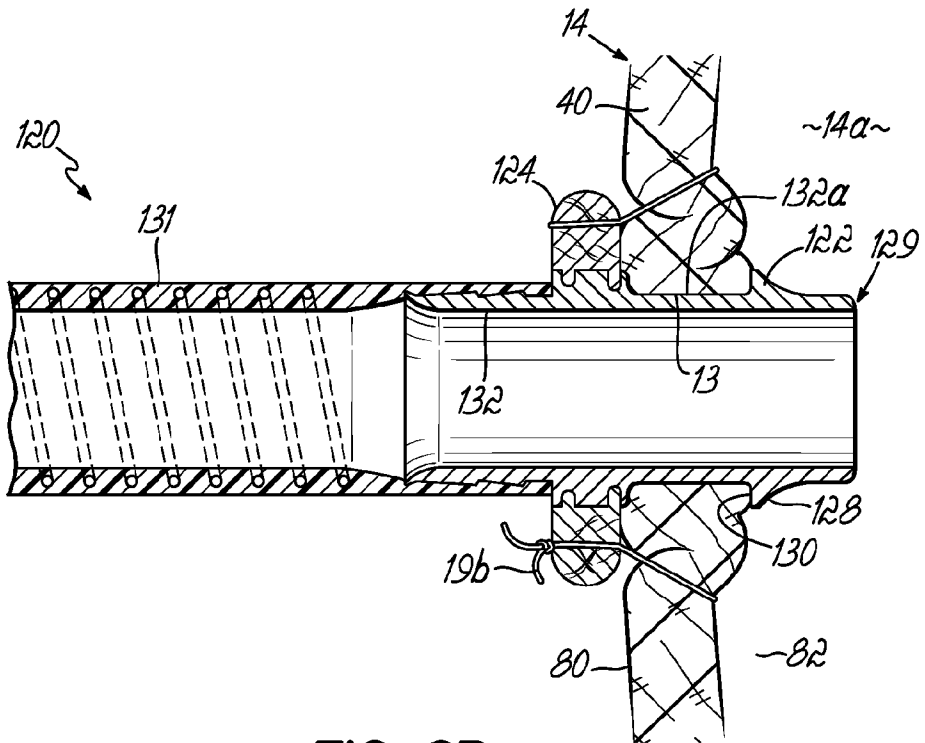

FIG. 6B

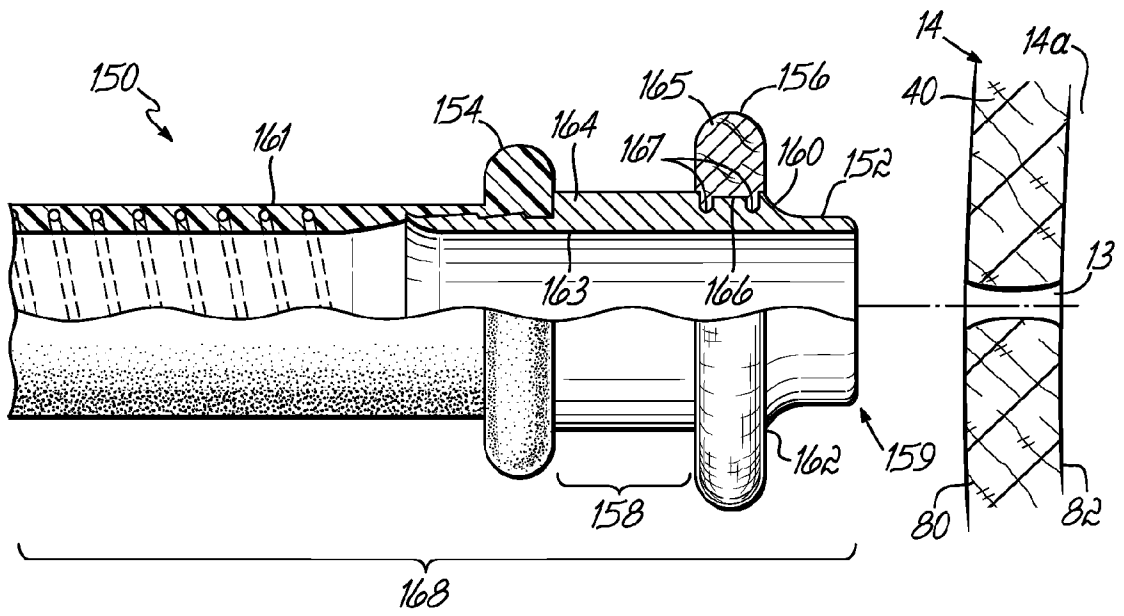

FIG. 7A

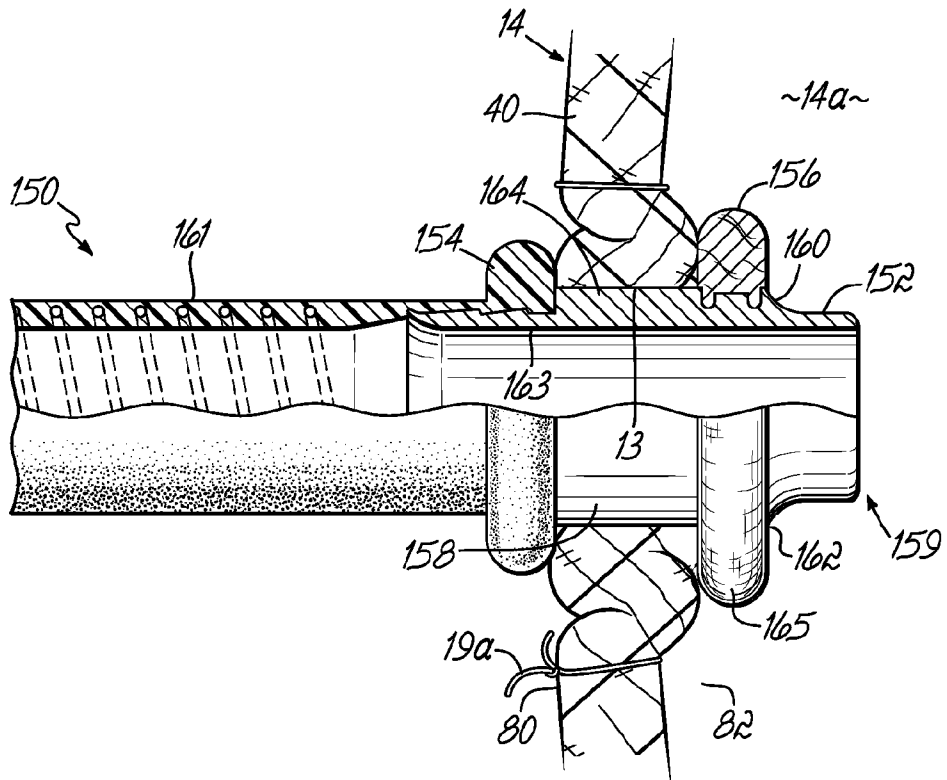

FIG. 7B



## INTERNATIONAL SEARCH REPORT

International application No.

PCT/US 08/66406

<b>A. CLASSIFICATION OF SUBJECT MATTER</b> IPC(8) - A61M 25/01 (2008.04) USPC - 604/264 According to International Patent Classification (IPC) or to both national classification and IPC		
<b>B. FIELDS SEARCHED</b> Minimum documentation searched (classification system followed by classification symbols) IPC8 : A61M 25/01 (2008.04) USPC : 604/264 Documentation searched other than minimum documentation to the extent that such documents are included in the fields searched IPC8 : A61M 25/00, A61M 25/14, A61M 25/16, A61M 39/00, A61M 39/10 (2008.04) USPC : 604/93.01, 604/48, 604/533, 604/523 Electronic data base consulted during the international search (name of data base and, where practicable, search terms used) PubWEST (PGPB,USPT,EPAB,JPAB), Google Scholar stitch\$, sutur\$, sewing, ring, rim, coupl\$, connect\$, implant\$, chamber, blood, pump, assist, flare, conic, cone, tip, point, connect\$, cannula, inlet, pipe, lumen, heart, atrium, ventricle, cardiac, vascular, vessel, vein, artery		
<b>C. DOCUMENTS CONSIDERED TO BE RELEVANT</b>		
Category*	Citation of document, with indication, where appropriate, of the relevant passages	Relevant to claim No.
X -- Y	US 2003/0093104 A1 (BONNER et al) 15 May 2003 (15.05.2003) see especially para [0045], [0053], [0056], [0057], [0080], fig 9, 12, 13	1, 6-10, 20-24, 36, 48, 49, 51-54, 57, 58, 60 ----- 2-5, 11-19, 25-35, 37-47, 50, 55, 56, 59
Y	US 2006/0235357 A1 (WOODWARD et al) 19 October 2006 (19.10.2006) see especially para [0035], [0041], [0042], [0055]	2-5, 13-19, 25-35, 39-47, 50, 55, 56, 59
Y	US 2004/0193004 A1 (TSUBOUCHI et al) 29 June 2004 (29.06.2004) see especially para [0031], [0033]	11-14, 37-40
<input type="checkbox"/> Further documents are listed in the continuation of Box C. <input type="checkbox"/>		
* Special categories of cited documents: "A" document defining the general state of the art which is not considered to be of particular relevance "E" earlier application or patent but published on or after the international filing date "L" document which may throw doubts on priority claim(s) or which is cited to establish the publication date of another citation or other special reason (as specified) "O" document referring to an oral disclosure, use, exhibition or other means "P" document published prior to the international filing date but later than the priority date claimed "T" later document published after the international filing date or priority date and not in conflict with the application but cited to understand the principle or theory underlying the invention "X" document of particular relevance; the claimed invention cannot be considered novel or cannot be considered to involve an inventive step when the document is taken alone "Y" document of particular relevance; the claimed invention cannot be considered to involve an inventive step when the document is combined with one or more other such documents, such combination being obvious to a person skilled in the art "&" document member of the same patent family		
Date of the actual completion of the international search 1 October 2008 (01.10.2008)		Date of mailing of the international search report <b>06 OCT 2008</b>
Name and mailing address of the ISA/US Mail Stop PCT, Attn: ISA/US, Commissioner for Patents P.O. Box 1450, Alexandria, Virginia 22313-1450 Facsimile No. 571-273-3201		Authorized officer: Lee W. Young PCT Helpdesk: 571-272-4300 PCT OSP: 571-272-7774