

M. KETCHAM.

4 Sheets—Sheet 1.

Stove.

No. 1,159.

Patented May 25, 1839.

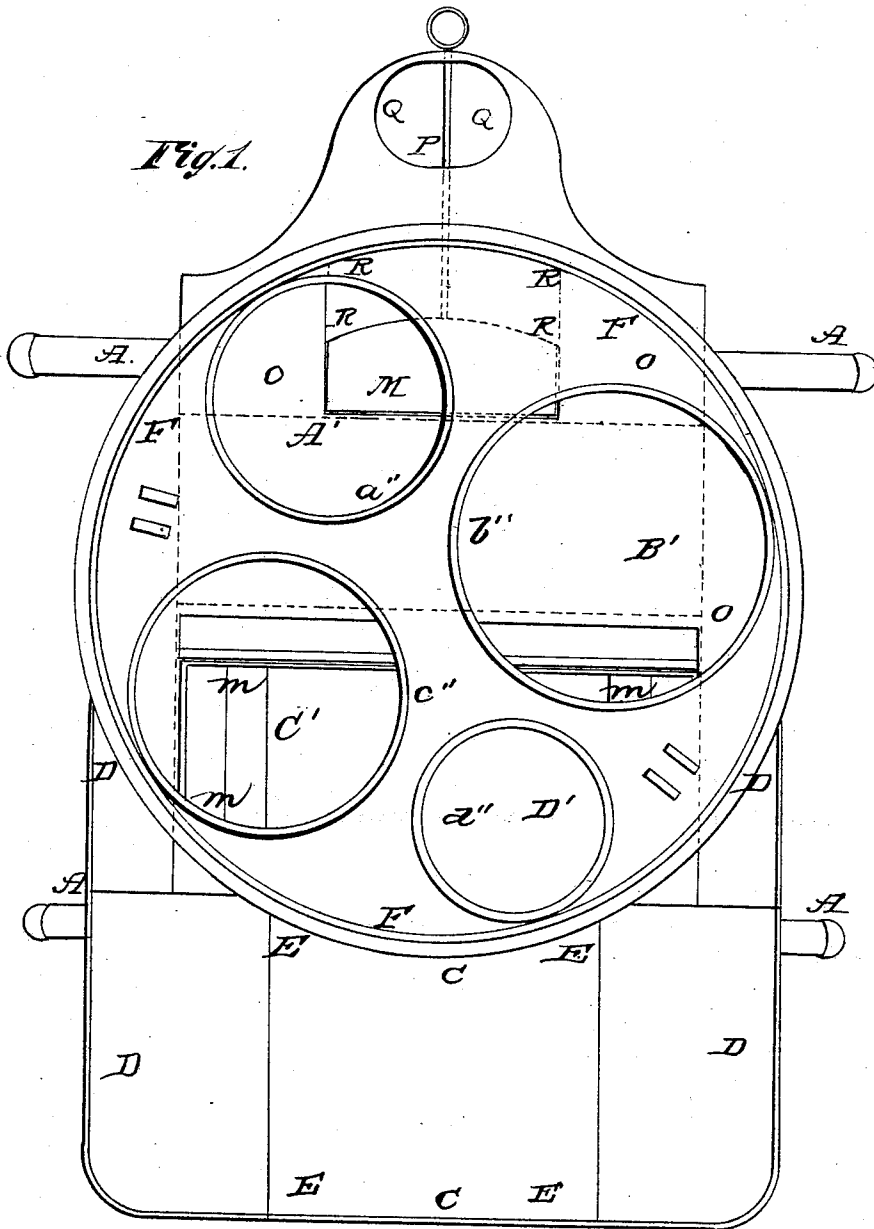

M. KETCHAM.

4 Sheets—Sheet 3.

Stove.

No. 1,159.

Patented May 25, 1839.

Fig. 3.

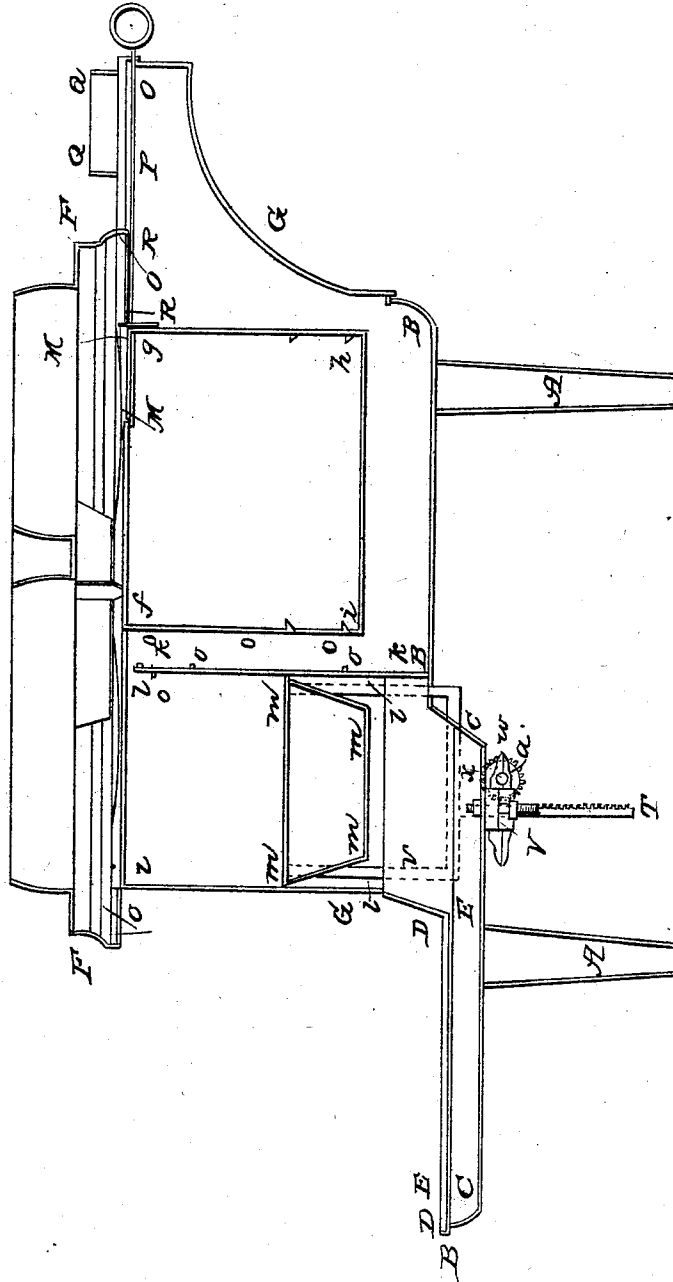

M. KETCHAM.
Stove.

4 Sheets—Sheet 4.

No. 1,159.

Patented May 25, 1839.

Fig 4

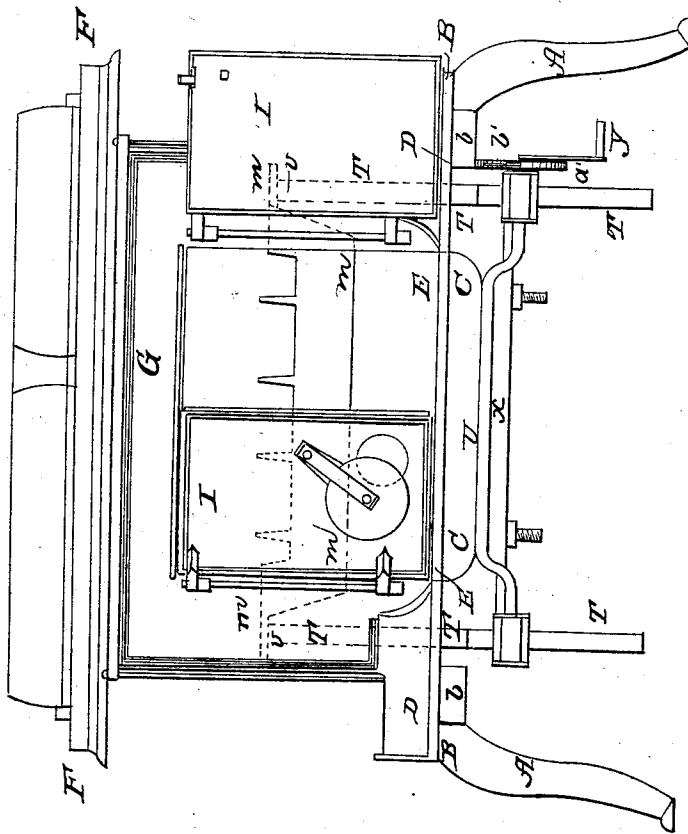

UNITED STATES PATENT OFFICE.

MICAH KETCHAM, OF BOSTON, MASSACHUSETTS.

STOVE.

Specification of Letters Patent No. 1,159, dated May 25, 1839.

To all whom it may concern:

Be it known that I, MICAH KETCHAM, have invented new and useful Improvements in Stoves, for Culinary and Such other Purposes in Which the Same May be Used.

The disposition, arrangement, and use of the several parts of these improvements, the principles thereof, and several modes in which I have contemplated the application of that principle or character, by which they may be distinguished from other inventions, together with those parts, improvements, or combinations, I claim as my inventions and discoveries, I have fully set forth and described in the following specification and accompanying drawings.

Plate 1, Fig. 1, represents the top view of my improved stove. Plate 2, Fig. 2, is a side elevation. Plate 3, Fig. 3 is a longitudinal section. Fig. 4, is a front view.

A, A, A, A, Figs. 1, 2, 3, 4, are the legs on which the stove rests. They are attached to the cast iron bottom plate B, B, by being wedged or driven between cleats or projections *b, b, b*, Figs. 2, 4, in the usual manner of connecting such parts. The cast iron bottom plate B, B, which supports the body of the stove, is shaped as represented in the drawings, and has connected to it, an ash box, or pan C, C, and a hearth D, D, D, Figs. 1, 2, 3, 4. That part E, E, Figs. 1, 3, 4, directly over the ash pan or box C, C, is made to slide outward, so that the ashes may be removed from the pan.

F, F, F, Figs. 1, 2, 3, 4, represents the cast iron rotary top plate of the form there exhibited. This plate revolves on a central pivot similar to other rotary tops.

G, G, are the front and rear cast iron ends. The top, bottom, side and end plates having suitable ledges formed around their edges, are placed on each other, and secured together by rods with heads screws and nuts in any of the usual modes generally practised of fitting such parts together; and which will readily be understood by all mechanics who manufacture stoves.

I, I, Fig. 4, are the front fire doors.

K, Fig. 2, is a small fire door in the side.

L, Fig. 2, is the oven door of which there may be another in the opposite end of the oven if desirable.

f, g, h, i, in the longitudinal section, Fig. 3, represents the oven.

l, l, l, l, in Fig. 3 is the fire place.

m, m, m, m, in Figs. 1, 2, 3, 4, is the fire

box or grate for fuel. Between this latter and the oven, there is a movable partition *k, k*, shown in Fig. 3. This partition rests between small projections *o, o, o, o*, from the sides of the stove, and being movable, may be raised at any time, so that any ashes or soot which may collect behind the same, or underneath the oven, may be drawn forward into the ash box, by the introduction of a shovel or poker or any other suitable instrument.

As wood is generally the kind of fuel to be used in this stove, should it be desirable to burn coal, the partition *k, k*, and interior of the fire place may be lined with fire stone, in any of the modes generally practised.

M, Figs. 1 and 3, is the damper or flue valve, with a rod P, for the purpose of shutting and closing the same. The top plate *o, o*, Figs. 1 and 3, has an opening R, R, R, R, in the same, through which the smoke passes from over the oven, into the funnel or exit flue, placed over the rim of the opening Q, Q, Figs. 1, 2, 3. A portion of the top plate *o, o*, as large, and similar in shape, to the damper, is sunk down equal to the thickness of the damper, so as to allow the upper surface of the damper to be level with the upper surface of the plate *o, o*, as seen in Fig. 3 in section. Thus it does not obstruct the passage of the smoke, as it passes over the oven to the chimney. By pushing the damper inward, the flame passes over the top of the oven, down through the space or opening R, R, and thence upward into the exit flue; and also by drawing the same outward, the opening R, R, is closed and the flame caused to descend between the partition *k, k*, and side *f i*, of the oven; thence under the oven to the exit flue as indicated by the arrows.

The ends of the fire box *m, m, m, m*, rest on the tops *v, v*, of the forked racks T, T, Figs. 2, 4. The forks of these racks pass through cylindrical holes in the bottom plate B, B. A pinion *w*, near each extremity of a rod *x*, plays into the teeth of the racks T, T. The rod *x* turns near each end in suitable bearings connected to the end of a bar U, Fig. 4. By turning the shaft *x*, by the handle *y*, Figs. 2, 4, the racks and fire box are raised or lowered at pleasure, so as to diminish or increase the distance between the coals and the bottom of the boiler, or vessel inserted in that opening of the revolving plate F, directly over the fire.

A ratchet wheel a' , is attached to the extremity of the shaft x , so that, by means of a click or pawl b' , the fire box may be retained at any height at pleasure.

5 A', B', C', D', Plate 1, are four circular spaces in the revolving plate F. Each of these spaces has a raised rim a'' , b'' , c'' , d'' , for the purpose of holding the vessels or
10 of the fire; and which by turning around the plate, may be alternately brought over the fire as occasion may require; and by a similar operation to that of other rotary stoves of this description.

Having thus described the different parts 15 of my improvements, I shall claim in the same as follows:

The movable front fire plate k k , for the object and purposes herein above set forth.

In testimony, that the above is a true de- 20 scription of my said invention and improvements, I have hereto set my hand, this sixteenth day of July in the year eighteen hundred and thirty eight.

MICAH KETCHAM. [L. s.]

Witnesses:

R. H. EDDY,

EZRA LINCOLN, JR.