

(No Model.)

2 Sheets—Sheet 1.

C. PARTINGTON.
COMBINED CROSSING AND SWITCH.

No. 410,560.

Patented Sept. 3, 1889.

Fig. 1.

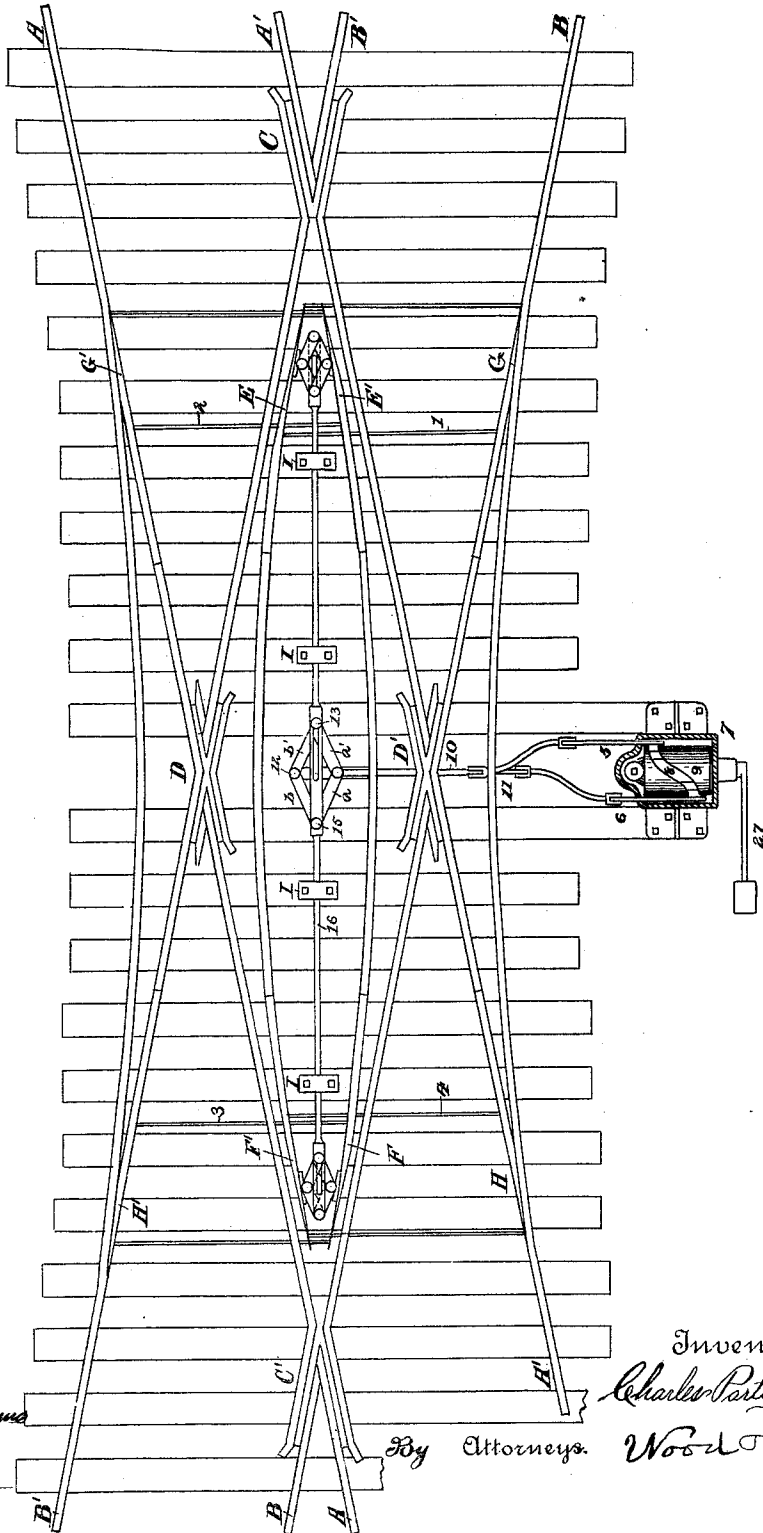

Witnesses

J. Watson Sims
Wm. L. Ross

Inventor

Charles Partington
By *Wood & Engle*

Attorneys.

(No Model.)

2 Sheets—Sheet 2.

C. PARTINGTON.
COMBINED CROSSING AND SWITCH.

No. 410,560.

Patented Sept. 3, 1889.

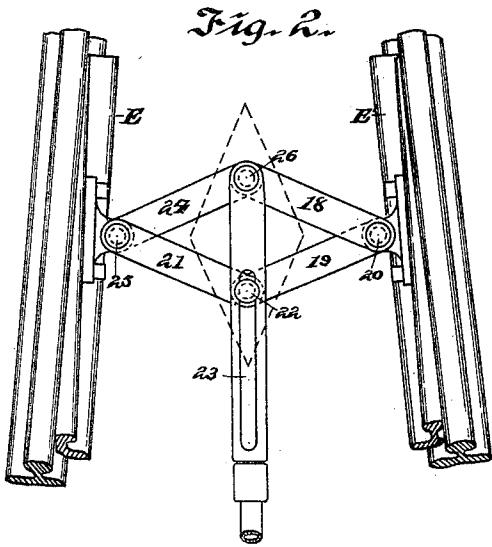

Fig. 3.

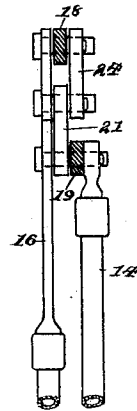

Fig. 4.

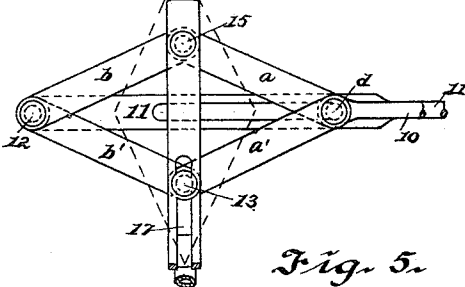
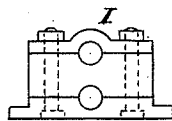
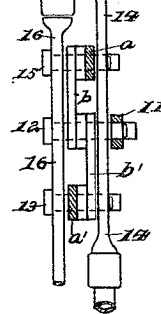
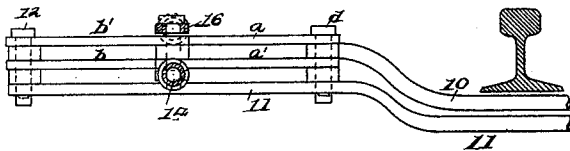

Fig. 5.



Witnesses

Watson Sims
Wm H. Rose

334

Inventor

Charles Partington

Attorneys *Wm H. Rose*

UNITED STATES PATENT OFFICE.

CHARLES PARTINGTON, OF CINCINNATI, OHIO, ASSIGNOR TO THE WEIR FROG COMPANY, OF SAME PLACE.

COMBINED CROSSING AND SWITCH.

SPECIFICATION forming part of Letters Patent No. 410,560, dated September 3, 1889.

Application filed May 23, 1889. Serial No. 311,836. (No model.)

To all whom it may concern:

Be it known that I, CHARLES PARTINGTON, a citizen of the United States, and a resident of Cincinnati, in the county of Hamilton and State of Ohio, have invented certain new and useful Improvements in Combined Crossing and Switch, of which the following is a specification.

The object of my invention is to provide suitable means for operating two sets of switches simultaneously. They are arranged between the frogs of the crossing, so that the switches connect one main line to another on the crossing, forming a combination cross-over or slip-switch. One difficulty in operating the mechanism has been to employ one switch-stand to move both sets of rails easily, the friction of the parts, as well as the strains of the moving rails, making it difficult to operate the rails. It is also desirable to move the rails positively and to avoid lost motion, which is apt to occur when cranks or rods are used by turning the rods due to the torsional strain. My invention overcomes this difficulty, because the rods are moved longitudinally, and hence avoid the strains upon the rods, which causes lost motion.

By employing the system of leverage herein shown and described I am enabled to move the switches with much less power employed than other devices heretofore employed for similar purpose, all of which will be fully set forth in the description of the accompanying drawings, making a part of this specification, in which—

Figure 1 is a top plan view of my improvement. Fig. 2 is an enlarged broken section of the same, showing the switch-rails closed. Fig. 3 is a broken sectional elevation of the parallel moving rods. Fig. 4 is an elevation of the journal-box-supporting rods. Fig. 5 is a sectional elevation showing the connection of the switch-bars to the parallel moving rods.

A A' represent one set of the main track-rails. B B' represent another main line crossing the former one. C C' represent the two end crossing-frogs, and D D' the central crossing-frogs. E E' represent the inner switch-rails at one end of the crossing, and F F' the inner switch-rails at the other end of the crossing. G G' represent the outside

switch-rails at one end of the crossing, and H H' the outside switch-rails at the opposite end of the crossing.

In operation the switch-rails E E' and F F' are moved simultaneously inward or outward. Switch-rail E is connected by a tie-bar 1 to the switch-rail G, so that said rails move simultaneously out or in, as the case may be, and switch E' is connected by a bar 2 to the switch-rail G', so as to move it out or in simultaneously with the movement of the said rail E'. On the opposite end the switch-rail F' is connected by bar 3 to the switch H', and the switch-rail F' is connected by a bar 4 to the switch-rail H, so that said outer rails are moved simultaneously by the movements of the inner rails.

The simultaneous movement of the switches is accomplished by means of duplex parallel moving rods preferably placed one above the other, each operated by a reciprocating bar 5 6 of the switch-stand 7, said bars being operated by pins journaled in the groove 8 of the switch-stand drum 9. The bars 5 6 are connected to switch-bars 10 and 11, as shown in elevation in Fig. 5. The upper bar 10 is journaled to links a a', which links are journaled to links b b', the latter moving on the center 12, to which they are journaled. The center 13, which journals the link a' to b', projects down through a slot in the upper parallel rod 16. Center 12 is journaled to the under switch-bar 11, and the center 15 is hinged to the under parallel rod 14.

The duplex switch-bars operate duplex links, each of which operates one of the duplex rods running at right angles to the plane of the switch-bar, the object being to do one-half of the work with the upper rod and the remaining one-half with the lower rod, both working simultaneously in unison, which compounds the leverage and enables the switches to be operated with far more ease and facility than is possible with a single rod. Thus the links a b operate the upper rod 16, and the links a' b' are hinged to and operate the lower rod 14, so that when strain is applied, say, to open the switches, the said links a a' b b' are drawn to the position shown by the dotted lines in Fig. 2.

The slot 17 in the upper rod is to allow the

journal 13, which is operated by the lower rod, to move freely through the upper rod, and the lower rod has a similar slot for the center 15 to move in likewise. The switch-bar 11 is similarly slotted to allow the center *d*, which hinges the links *a a'* together, to move in said slot without affecting the operation. The bars 10 and 11 travel simultaneously in opposite directions, the lower switch-bar 11 operating on links *b b'*, and the upper switch-bar 10 operating on links *a a'*. Hence whenever the switch-stand is turned it brings those links into position shown in full lines, Fig. 2, or in position shown in dotted lines, as the case may be.

The switch-rails are connected at their ends to the duplex parallel rods 14 and 16 by duplex links, which have the same movement as those forming the central connections of the switch-rods. Thus the switch-rail *E'* is hinged to links 18 and 19 by the center 20. Link 19 is hinged to link 21 by center 22, which moves in the slot 23 of the upper parallel rod. The switch-rail *E* is hinged to links 21 and 24 by the center 25, and links 18 and 24 are hinged together by center 26, to which the upper parallel rod 16 is hinged, and this rod is provided with a slot 23, so that the center 22, to which the lower parallel rod is hinged, will pass freely in the said slot and allow the lower rod to operate the links 19 and 21. The duplex rods 14 and 16 are thus moved in opposite directions by the center compound link movement, each operating to move the switch-rails inward or outward, as the case may be, one operating on the links 18 and 24, and the other on links 19 and 21, the two traveling in opposite directions; and the center 22 traveling in slot 23 toward the center, as the rod 16 travels from the center, necessitates the slot 23 to be twice as long as the distance to which the slot-rail moves, which, say, is five inches.

The rods 14 and 16 are suitably guided in guides, which are preferably of the form shown in Fig. 4, which are placed at suitable distances apart and secured to the ties, as indicated by letter *L*, Fig. 1.

The ends of the duplex moving bars and switch-rail connections are each the counterpart of the other.

27 represents a lever rotating the switch-drum 9 and moving the switch-bars 10 and 11. These bars travel in opposite directions and open or close the links *a a' b b'*, as the case may be, which in turn drive the parallel rods

and move the end link mechanism and draw the switch-rails inward or outward, as desired.

It is obvious that the parallel switch-bars 10 and 11 can be operated by other mechanism than the double-acting stand here shown; but this I deem the best.

It is also obvious that the duplex rods 14 and 16 can be used to move the switch-rails at one end of the crossing only.

Having described my invention, what I claim is—

1. A combination cross-over or slip-switch device, combined with and operated by duplex horizontally-moving rods actuating duplex-jointed links, substantially as specified.

2. In combination with the duplex rods 14 and 16, having connection with switch-rails and operated by a switch-stand, the central duplex links *a a' b b'*, hinged to each other and to the duplex rods and switch-bars, substantially as herein described.

3. In combination, the duplex rods 14 and 16, hinged, respectively, to opposing duplex links, which duplex links are hinged to the switch-rails, whereby the said rails are moved toward or from each other as the duplex rods are moved, substantially as herein set forth.

4. In combination, the duplex rods 14 and 16, respectively hinged to opposing duplex links at their center and at either end of the crossing, the latter links being hinged to their respective switch-rails, whereby the moving of the duplex rods simultaneously moves the switch-rails of the crossing, substantially as specified.

5. The combination of the double-acting switch-stand, the duplex switch-bars 10 and 11, and the duplex central links hinged to said bars and conversely hinged to duplex rods 14 and 16, which are connected with the switch-rails, substantially as specified.

6. The combination of the parallel duplex rods 14 and 16, each provided with slots 23 and 17, and hinged to duplex links at the two ends and to the central duplex links operated by the switch-bars, substantially as specified.

In testimony whereof I have hereunto set my hand.

CHARLES PARTINGTON.

Witnesses:

RUFUS S. SIMMONS,
T. SIMMONS.