

910,381.

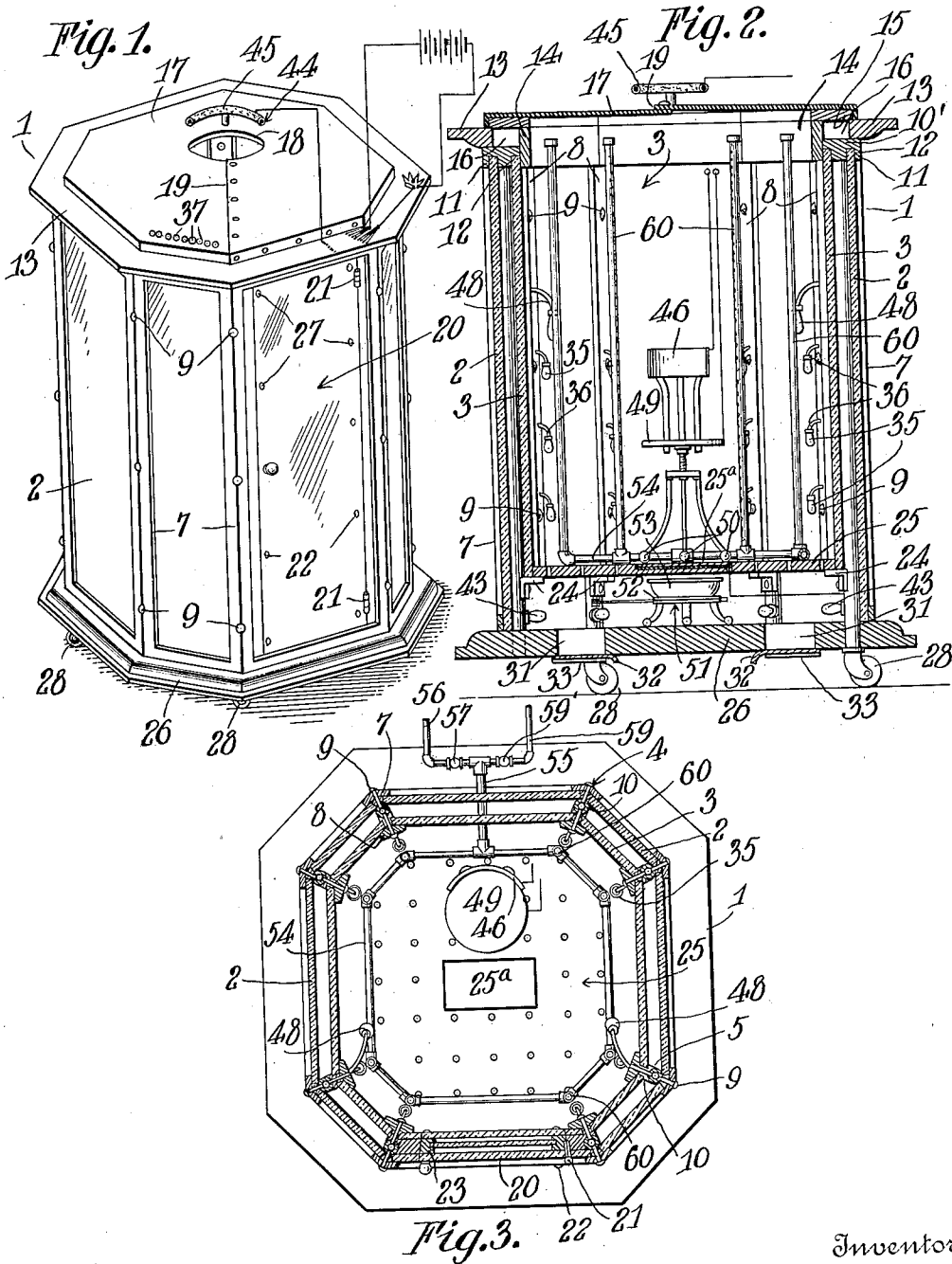

Witnesses
C. E. Smith,
C. H. Griesbauer.

Inventor
John Hermann.

by *A. B. Wilson & Co.*
 Attorneys

910,381.

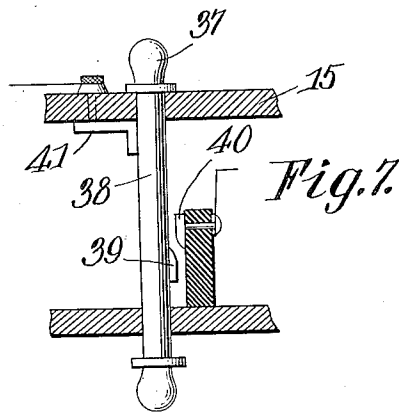
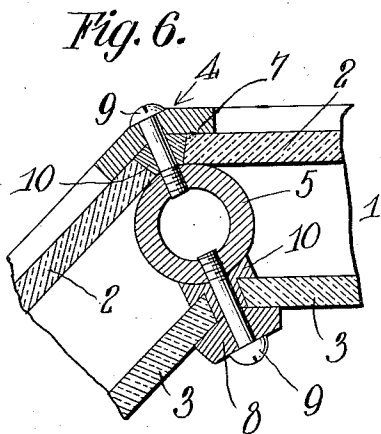
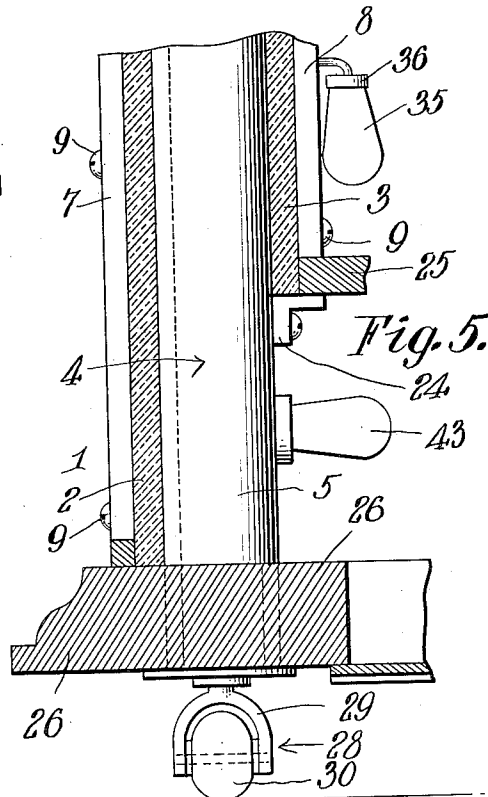
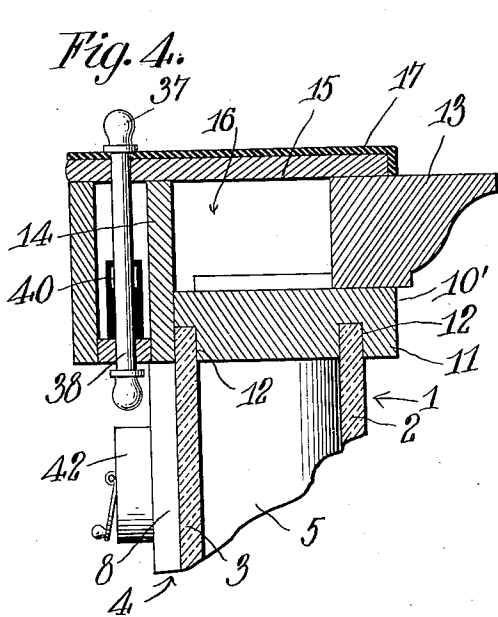

Witnesses

C. E. Smith.
 C. H. Guesbauer.

Inventor

John Hermann.

By A. B. Wilson & Co
 Attorneys

UNITED STATES PATENT OFFICE.

JOHN HERMANN, OF SAGINAW, MICHIGAN.

BATH-CABINET.

No. 910,381.

Specification of Letters Patent.

Patented Jan. 19, 1909.

Application filed March 25, 1907. Serial No. 364,439.

To all whom it may concern:

Be it known that I, JOHN HERMANN, a citizen of the United States, residing at Saginaw, in the county of Saginaw and State of Michigan, have invented certain new and useful Improvements in Bath-Cabinets; and I do declare the following to be a full, clear, and exact description of the invention, such as will enable others skilled in the art to which it appertains to make and use the same.

My invention relates to improvements in bath cabinets, and more particularly to a sanitary device of this character heated and lighted by electricity, and in which sweat baths and light baths may be taken.

One object of the invention is to provide a bath cabinet of this character which will be of simple, strong and durable character and entirely sanitary.

Another object of the invention is to provide a bath cabinet of this character, in which its bottom will be heated.

Another object of the invention is to provide a cabinet of this character in which the switches or controlling devices of the various electric circuits may be operated from within the cabinet by a person therein or from without the cabinet by an attendant.

Another object of the invention is to provide a bath cabinet of this character which will be constructed of plates of glass which are connected by water tight joints so that it will be air and water tight and may be thoroughly washed out and cleaned after it is used.

A further object of the invention is to improve and simplify the construction and operation of devices of this character and thereby render the same more convenient and efficient.

With the above and other objects in view, the invention consists of certain novel features of construction, combination and arrangement of parts hereinafter described and claimed.

In the accompanying drawings,—Figure 1 is a perspective view of my improved electric bath cabinet; Fig. 2 is a vertical sectional view through the same; Fig. 3 is a horizontal sectional view; Figs. 4 and 5 are detail vertical sectional views through the top and bottom of the cabinet; Fig. 6 is a detail horizontal sectional view, showing the water tight joint or connection between the glass

plates which form the sides of the cabinet, 55 and Fig. 7 is a detail view of one of the switches or circuit closing devices which may be operated from either the inside or outside of the cabinet.

Referring to the drawings by numeral, 1 60 denotes my improved electric bath cabinet which, as shown, is of prismatic form and constructed almost entirely of glass, which may be transparent, opaque or colored. Each of the rectangular sides of the cabinet 65 are composed of inner and outer glass plates 2, 3 which are spaced apart and secured together and to the abutting vertical or side edges of the similar plates of the adjacent sides, by a water and air tight joint 4. Each 70 of the latter comprises a vertically extending metal tube 5, disposed between said glass plates and adapted to serve as conduits for electric circuit wires. The glass plates are retained upon this tubular standard 5 by 75 inner and outer vertically extending clamping bars 7, 8 which are secured to the tube by screws or the like 9, a suitable packing 10 being interposed between said parts and the abutting vertical edges of the glass plates 2, 80 3, as clearly shown in Fig. 6 of the drawings. The upper ends or edges of the glass plates 2, 3 are connected by a surrounding rim or frame 10' constructed preferably of wood and comprising a sectional lower bar 11 having 85 grooves 12 to receive the glass plates, an outer sectional molding 13, an inner sectional cleat or molding 14 and a sectional top 15, which latter closes a space 16 in the frame 10', through which the electric wires or con- 90 ductors may extend.

The top 17 of the cabinet is preferably made of rubber or other flexible water proof material, and has its surrounding edge secured to the top portion 15 of the frame 10, as 95 clearly shown in Fig. 4 of the drawings. This top 17 is formed with an opening 18 to receive the neck of the person using the cabinet, and also with a slit or joint 19 extending from the said neck opening to the outer edge 100 of the cabinet adjacent to where its door 20 is located. Any suitable means may be provided for connecting the overlapping edges of the slit or joint 19, so that the latter may be closed after the person has entered the 105 cabinet through the door 20. This door 20 is formed by one of the sides of the cabinet and is hingedly mounted upon one of the

adjacent sides, as shown at 21. The inner and outer glass plates of the door are united by bolts or the like 22 to the inwardly extending flanges of a surrounding channel metal frame or beam 23, as clearly shown in Fig. 3. The lower or bottom edges of the inner glass plates 2 of the sides rest upon angle metal brackets 24 secured upon the lower portions of the tubular standards or uprights 5, and are also adapted to support a horizontal perforated metallic plate 25, which forms the floor or real bottom of the cabinet and is spaced above a false bottom 26, which may be made of wood or of any other suitable material. The lower ends of the tubular uprights 5 are secured in this bottom 26. The cabinet is preferably mounted upon casters 28, which have their forked or yoked frame 29 swiveled in the lower ends of the tubes 5 and carrying rubbers rollers 30. At suitable points in the bottom 26 are formed openings 31, which are closed by doors 32 slidably mounted on guides 33 upon the under face of said bottom.

The cabinet is preferably heated by incandescent electric lamps 35 mounted in water-proof fixtures 36 arranged in vertical rows upon the inner clamping strips 8. Any kind and number of lights may be provided and they may be of any color to give different colored light baths for the treatment of certain diseases. They are, however, preferably arranged in vertical rows within the cabinet, as shown, and each row is controlled by a separate switch or circuit-closing device 37. These circuit closing devices are arranged at a suitable point in the surrounding top frame 10 of the cabinet and may be of any desired form and construction, so that they may be operated either from within the cabinet by the occupant thereof or from without the cabinet by an attendant. One of these devices is clearly shown in Fig. 7 of the drawings, and consists of a slidable member or element 38, carrying a contact plate 39 which is adapted to be moved into and out of engagement with a similar contact plate 40 suitably mounted upon a block of insulation and connected to one of the terminals of an electric circuit, the other terminal of said circuit being connected to a plate 41, with which the sliding element 38 is always in contact. The upper end of the sliding bar or element 38 projects outside of the cabinet, and its lower end projects within the cabinet, so that it may be operated as stated. All of the circuits controlled by these switches unite and pass through a rheostat or dimmer 42 mounted within the cabinet so that the occupant thereof may regulate the heat therein by brightening or dimming the lights. In order to heat the bottom or floor 25 of the cabinet so that the occupant's feet will be kept warm I provide in the space between said bottom and the bottom 26, a plurality of electric lamps 43, the circuit through which is also controlled by one of the switches 37. One of these lights 43 is mounted in a suitable base or socket over each of the openings 31 in the bottom 26.

On the outer side of the top of the cabinet is a curved neck piece 44, which is preferably made of hard rubber and has a sponge covering 45, which when wet forms an electrode. A pair of metallic handles 48, which also form electrodes, are secured within the cabinet and one or both of them may be grasped by the patient. On the perforated metal plate 25 is an electrode plate 25^a, insulated therefrom. A stool or seat 49 is movable in the cabinet, and has on its seat an electrode plate 46, which is vertically adjustable, so that it may be caused to engage the back of the patient at any point.

In practice, suitable pole changing devices will also be included to enable the currents to run in different directions. The perforated metal plate 25 also forms an electrode, and on the same, within the cabinet is a metallic stool or seat 49, which also forms an electrode, and is provided with glass or other suitable non-conducting feet 50. Suitable conductors and switches are in practice provided, to include any two or all of the said elements 44, 46, 48, 25 and 49 in a circuit, including the body of the patient, so that a current may be passed through the body of the patient from the neck to the feet, back, or either hand; from the back to the neck, feet, or either hand; from one hand to the other; or from the feet to the back, neck or either hand, as may be required.

In the bottom of the cabinet, under the perforated plate 25, is an electric heater 51, here shown as composed of two separate and movable sections 52. Such heater is in practice provided with suitable conductors and may be caused to heat the air in the cabinet to any desired extent by switches located inside and outside of cabinet. If it be desired to give the patient a steam bath, a suitable vessel 53, containing water, may be placed on the electric heater and heated to or above the boiling point. The steam will readily pass through the openings in the perforated plate into the cabinet. Any suitable medicament may be placed in the vessel 53, to generate a vapor, if desired.

It will be understood that the cabinet may be interiorly heated by the electric lamps, or by the heater, or by both, as may be desired.

The construction, use and advantages of the invention will be readily understood from the foregoing description taken in connection with the accompanying drawings. After the person has stepped into the cabinet through the door 20 and is seated

upon the adjustable stool placed upon the perforated floor 25, said door is closed and the joint 19 is secured, so that only the head of the person is without the cabinet. The lights or electric heater may then be turned on or regulated by means of the switches either by the occupant himself or by an attendant, who, owing to the transparent walls of the cabinet may readily see the person within. After the bath has been taken, the interior of the cabinet may be thoroughly washed and cleaned to remove all germs therefrom, by turning on a hose within the same. Owing to the waterproof joints between the inner walls of the sides of the cabinet and the waterproof mounting of the electric lights, no part of the cabinet will be injured by a thorough washing of this character. It will be noted that various kinds of baths may be taken within the cabinet.

On the perforated bottom plate 25 is a pipe 54 which extends around said plate at a slight distance within the walls of the cabinet. A pipe 55 leads outwardly from said pipe 54 and is coupled to a hot water supply pipe 56, having a valve 57, and a cold water supply pipe 59 having a valve 59'. Vertical pipes 60 are connected to and rise from the pipe 54 and are provided with perforations directed toward the center of the cabinet. Said pipes enable the patient to take a hot or cold shower, either while being electrically treated or not, as will be understood. The said pipes 60 are disposed a slight distance within the vertical series of electric lamps, as shown, so that said pipes are disposed between the patient and the said lamps and serve to guard the latter and prevent them

from being broken by movements of the patient.

Various changes in the form, proportion, and the minor details of construction may be resorted to without departing from the principle or sacrificing any of the advantages of the invention, as defined by the appended claims.

Having thus described my invention, what I claim as new, and desire to secure by Letters-Patent, is,—

1. A cabinet of the class described having a perforated bottom, a false bottom disposed therebelow and spaced therefrom, said false bottom having openings provided with closures and electric lamps arranged in the space between said bottoms.

2. A cabinet of the class described having a perforated metallic bottom, an electrode stool disposed on and insulated from said bottom, a false bottom disposed below and spaced from said bottom proper, said false bottom having openings provided with closures and electric lamps arranged in the space between said bottoms.

3. A cabinet of the class described having a seat therein, a plurality of electric lamps arranged therein in position to heat and light the patient on the seat, and guards for said lamps comprising spraying pipes disposed between said lamps and said seat.

In testimony whereof I have hereunto set my hand in presence of two subscribing witnesses.

JOHN HERMANN.

Witnesses:

HENRY A. ROESER,
SIDNEY G. ARNOLD.