

W. S. COOPER.

OVERFLOW VALVE FOR WASH BASINS.

No. 267,156.

Patented Nov. 7, 1882.

FIG. 1.

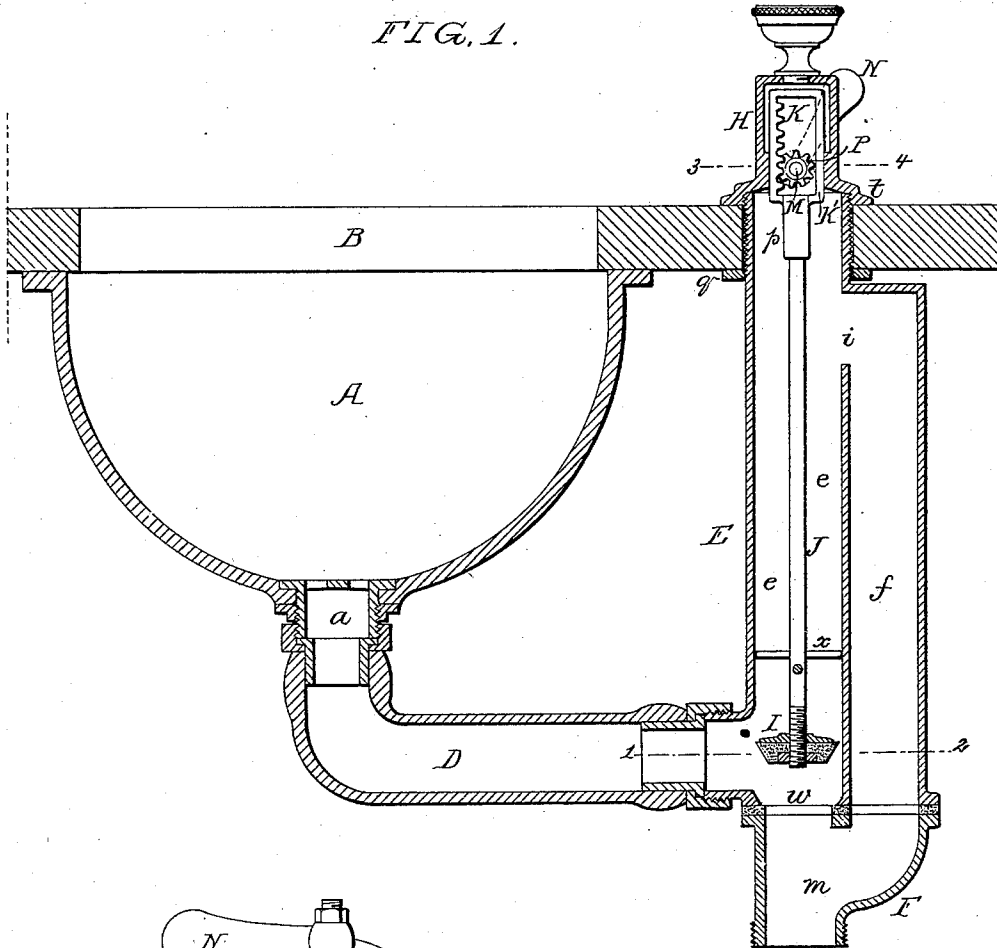

FIG. 3.

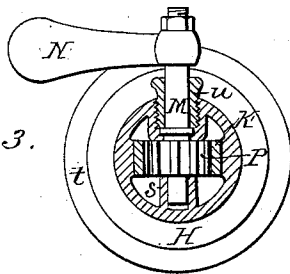
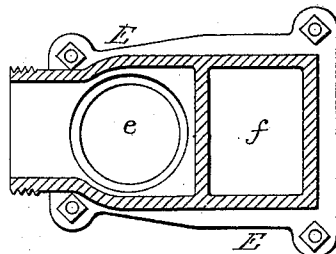

FIG. 2.



WITNESSES:
David S. Williams
Harry Drury

INVENTOR:
William S. Cooper
 by his Attorneys
Howson and Forsy

W. S. COOPER.

OVERFLOW VALVE FOR WASH BASINS.

No. 267,156. $\frac{5}{8}$

Patented Nov. 7, 1882.

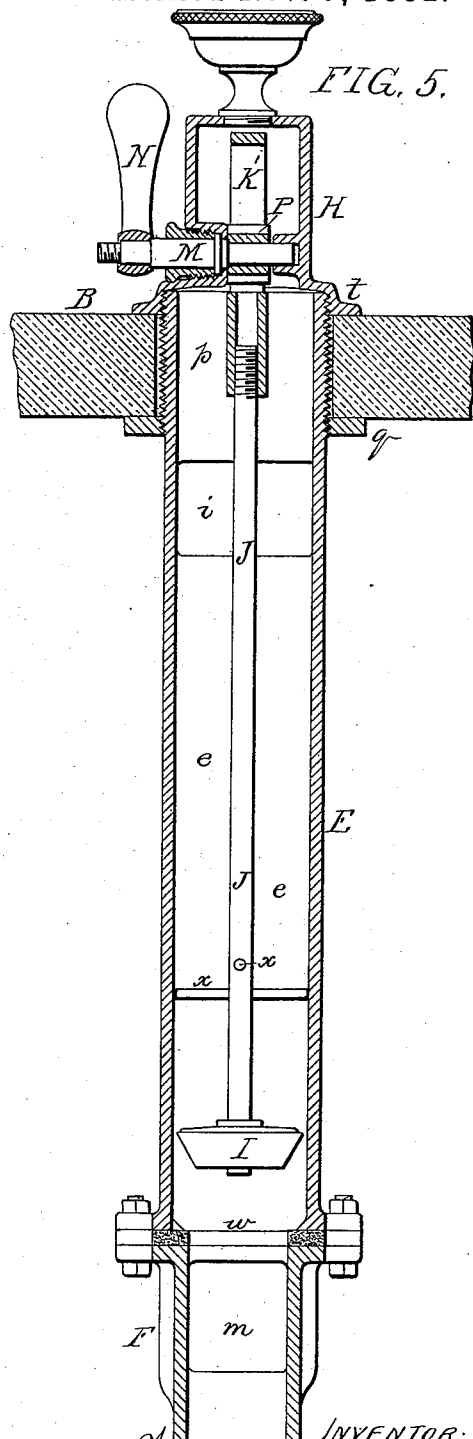
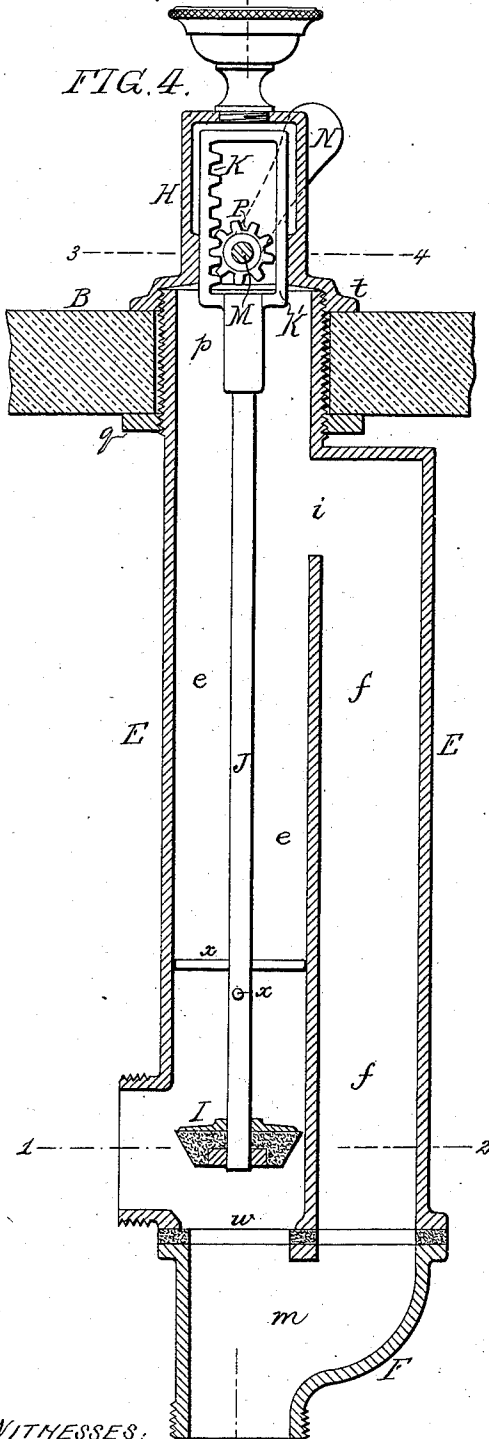

WITNESSES:

David S. Williams
Harry Drury

INVENTOR:

William S. Cooper
by his attorneys
Howson and Ford

UNITED STATES PATENT OFFICE.

WILLIAM S. COOPER, OF PHILADELPHIA, PENNSYLVANIA.

OVERFLOW-VALVE FOR WASH-BASINS.

SPECIFICATION forming part of Letters Patent No. 267,156, dated November 7, 1882.

Application filed September 17, 1881. (No model.)

To all whom it may concern:

Be it known that I, WILLIAM S. COOPER, a citizen of the United States, residing in Philadelphia, Pennsylvania, have invented certain
5 Improvements in Overflow-Valves for Wash-Basins, of which the following is a specification.

My invention relates to improvements in mechanism for maintaining a proper supply
10 of water in a wash-basin without the aid of the usual detachable plug, preventing the overflow of water from the basin, and promptly disposing of the waste water. These objects I attain in the manner which I will now proceed to describe, reference being had to the
15 accompanying drawings, in which—

Figure 1, Sheet 1, is a vertical section of a wash-basin with my improved waste and overflow device; Fig. 2, a sectional plan on the
20 line 1 2; Fig. 3, a sectional plan on the line 3 4; Fig. 4, Sheet 2, a view of part of Fig. 1; and Fig. 5, a vertical section on the line 5 6, Fig. 4. Fig. 1 is drawn to a smaller scale than the remaining figures.

25 A is the wash-basin, and B the top of the wash-stand, to the under side of which the basin is attached in any suitable manner.

To the outlet-branch *a* of the basin is secured the upturned end of the waste-pipe D,
30 which communicates with the compartment *e* of the overflow-chest E, the latter having a second compartment, *f*, communicating with the first at *i*, and both communicating with the outlet *m* of a casing, F, which is secured
35 to the bottom of the chest E, a suitable packing intervening between the two. The chest E has at the top a tubular extension, *p*, which is threaded externally and passes through the top B of the stand, and is secured thereto
40 below by a nut, *g*, and above by the internally-threaded flange *t* of a cap, H.

A valve, I, attached to the lower end of the valve-spindle J, is adapted to a seat, *v*, in the bottom of the compartment *e* of the
45 overflow-chest, this seat being formed by the packing between the said chest E and the casing F below the same.

To the upper end of the rod is attached a rack, K, forming part of a quadrangular frame,
50 K', which is contained within and guided by the cap H.

A spindle, M, provided with a suitable handle, N, projects transversely into the cap H, and has one bearing in an internal projection, *s*, in the cap and the other in a stuffing-box, *w*,
55 the spindle being provided with a pinion, P, which gears into the above-mentioned rack.

The valve-spindle J is guided at a short distance above the valve by rods *x x*, driven through holes in the spindle and extending
60 nearly across the compartment *e* of the overflow-chest.

When the valve I has been raised the water will pass from the basin through the outlet *a*, pipe D, and outlet *m*, and through the waste-pipe communicating with the latter; but should
65 the valve be closed and water allowed to flow into the basin it cannot reach a higher level therein than that determined by the position of the communication *i* between the two com-
70 partments of the overflow-chest.

The usual detachable plug fitted to the outlet of an ordinary wash-basin is dispensed with, as the closing of the valve insures the
75 introduction of a proper supply of water into the basin, from which the water cannot overflow, owing to the freedom of the discharge therefrom, due to the large area of the opening *i* and of the portion *f* of the overflow-chest.

The handle N is such that when the valve
80 is raised said handle occupies an inclined position on one side of a vertical line drawn through the center of the spindle M, and when the valve is depressed the handle occupies an
85 inclined position on the opposite side of said line, so that the handle tends to maintain the valve and valve-rod in either of the positions named after the adjustment has been effected.

I claim as my invention—

The combination of the overflow-chest, the
90 valve I, and valve-spindle J, with rack K, the cap H, the pinion P, the spindle M, and the handle N, adapted to hold the valve-rod in either of its extreme positions, as set forth.

In testimony whereof I have signed my name
95 to this specification in the presence of two subscribing witnesses.

WILLIAM S. COOPER.

Witnesses:

HARRY DRURY,
HARRY SMITH.