

(19) **DANMARK**

(10) **DK/EP 3589227 T3**



Patent- og
Varemærkestyrelsen

(12) **Oversættelse af
europæisk patentskrift**

-
- (51) Int.Cl.: **A 61 B 90/00 (2016.01)** **A 61 C 9/00 (2006.01)** **A 61 C 19/045 (2006.01)**
- (45) Oversættelsen bekendtgjort den: **2021-05-25**
- (80) Dato for Den Europæiske Patentmyndigheds bekendtgørelse om meddelelse af patentet: **2021-02-24**
- (86) Europæisk ansøgning nr.: **18712954.9**
- (86) Europæisk indleveringsdag: **2018-03-05**
- (87) Den europæiske ansøgnings publiceringsdag: **2020-01-08**
- (86) International ansøgning nr.: **FR2018050498**
- (87) Internationalt publikationsnr.: **WO2018158551**
- (30) Prioritet: **2017-03-03 FR 1751748**
- (84) Designerede stater: **AL AT BE BG CH CY CZ DE DK EE ES FI FR GB GR HR HU IE IS IT LI LT LU LV MC MK MT NL NO PL PT RO RS SE SI SK SM TR**
- (73) Patenthaver: **Modjaw, 11-13 Avenue Albert Einstein, 69100 Villeurbanne, Frankrig**
- (72) Opfinder: **JAISSON, Maxime, 186 chemin du Blardet, 73800 Les Marches, Frankrig**
- (74) Fuldmægtig i Danmark: **Zacco Denmark A/S, Arne Jacobsens Allé 15, 2300 København S, Danmark**
- (54) Benævnelse: **Indretning til fastgørelse i underkæbe af en lokaliseringsmarkør**
- (56) Fremdragne publikationer:
DE-A1-102014 111 643
DE-U1-202015 105 356
US-A- 4 432 728
US-A1- 2006 201 520
US-A1- 2016 317 108

FIELD OF THE INVENTION

The present invention relates to a device for mandibular attachment of a localization marker, notably intended to be used for recording the mandibular kinematics of an individual.

PRIOR ART

The document WO 2013/030511 describes a method for designing a dental apparatus for an individual in which the mandibular kinematics recorded on said individual are used to animate digital models of the upper and lower dental arches of the individual.

To do so, it is firstly necessary to calibrate the digital models of the arches to the planes and reference points of the individual.

Next, the mandibular kinematics of the individual are recorded. To this end, the individual is equipped with several markers:

- one or more markers are positioned at the level of the forehead of the individual, through a support encircling the forehead,
- one or more markers are positioned at the level of the lower jaw (mandible) and rigidly attached to the teeth of the lower arch.

A camera adapted for detecting said markers is oriented towards the face of the patient and records the displacements of the markers during movements of the mandible.

The mandibular markers may be attached directly onto the teeth of the lower arch, but this requires the use of a device for moving apart the lips to make them visible by the camera.

Another solution is to attach the marker to an intermediate support which is itself attached to the mandible. Said intermediate support must be attached in a rigid manner to the mandible, because any relative displacement with respect to the mandible during the acquisition of the mandibular kinematics would deteriorate the precision of the recording. In addition, the wearing of this intermediate support must be comfortable for the individual.

The marker is preferably supplied separately from the support, to enable firstly putting in place the support alone in the mouth of the patient, then, once the support is attached on the mandible, the marker is mounted on the support. However, if the force for putting in place the marker on the support is too high, the support may be displaced with respect to the mandible.

The documents DE 10 2014 111643 A1 and DE 20 2015 105356 U1 both describe a snap-coupling connection system with corresponding lugs and recesses, between an extra-oral marker and its device for attaching on the jaw, in particular the mandible, of a patient.

SUMMARY OF THE INVENTION

5 An aim of the invention is thus to design a support for a mandibular localization marker that enables a rigid attachment of the marker with respect to the individual, with a system for attaching the marker that minimises the force of mounting the marker on the support.

To this end, the invention proposes a device for localization of the lower jaw of an individual, comprising:

(a) a marker comprising an inner face provided with two attachment lugs, and
10 (b) a device for attaching said marker to the lower jaw of the individual, comprising:
- an intra-oral portion having a general U shape adapted for coming into contact with the outer face of the teeth of the lower jaw,

- an extra-oral portion comprising an attachment element for the marker,
- a connecting portion connecting the intra-oral portion and the extra-oral portion,
15 the attachment element comprising two recesses each adapted for receiving a respective lug of the marker, said recesses being separated by a tab adapted for being elastically deformed when one of the lugs is engaged in a respective recess,

the marker being attached to the extra-oral portion of the attachment device by engagement of each lug in a respective recess, the elastically deformed tab exerting a
20 pressure force on one of the lugs.

According to an embodiment, the attachment element further comprises two lateral fins adapted for being deformed elastically when each lug is engaged in a respective recess so as to exert a pressure force on the inner face of the marker.

In a particularly advantageous manner, the intra-oral portion is flexible in the plane of
25 the U.

According to a preferred embodiment, the face of the intra-oral portion oriented towards the teeth has a rough surface.

In an advantageous manner, the face of the intra-oral portion oriented towards the teeth comprises at least one notch adapted for engaging in a relief of the teeth of the lower
30 jaw.

Preferably, the intra-oral portion is provided at its ends with divisible segments.

According to an embodiment, the attachment element comprises means for guiding and/or abutting the marker.

In a preferred manner, the attachment element is configured to enable dismantling of
35 the marker.

In an advantageous manner, the connecting portion is designed so that, when the device is in place in the mouth of the individual, a section of said connecting portion extends substantially in the plane of the closing of the lips.

5 According to an embodiment, the intra-oral portion, the extra-oral portion and the connecting portion are integrally formed.

The intra-oral portion, the extra-oral portion and the connecting portion are advantageously constituted of a biocompatible material.

According to an embodiment, the marker comprises a plurality of reflective patches.

10 The invention also relates to a localization system comprising an infrared camera and an assembly formed of the attachment device and the marker such as described previously.

15 Finally, the invention relates to a method for recording the mandibular kinematics of an individual by means of the localization system such as described previously, in which the marker is attached on the teeth of the mandibular arch of the individual through the attachment device, another marker provided with a plurality of reflective patches is attached on the forehead of the individual, and the relative displacements of said markers during mandibular movements made by the individual are recorded with the infrared camera.

20 To attach the marker on the attachment device, the inner face of the marker provided with two attachment lugs is presented facing the extra-oral portion of the device, a first lug is engaged in a first recess then a second lug in a second recess while elastically deforming the tab such that said tab exerts a pressure force on the second lug.

DESCRIPTION OF THE FIGURES

25 Other characteristics and advantages of the invention will become clear from the detailed description that follows, with reference to the appended drawings in which:

- figure 1 is a perspective view of the mandibular attachment device equipped with a localization marker,
- figure 2 is a perspective view of the mandibular attachment device of figure 1 in the absence of the localization marker,
- 30 - figure 3 is a front view of the mandibular attachment device of figure 2,
- figure 4 is a side view of the mandibular attachment device of figure 2,
- figure 5 is a top view of the mandibular attachment device of figure 2,
- figure 6 is a side view of the mandibular marker.

DETAILED DESCRIPTION OF THE INVENTION

Figure 1 is a perspective view of a marker 2 mounted on a mandibular attachment device 1 according to the invention.

5 The localization technology of the marker is not limiting.

In the example illustrated on figure 1, the marker comprises four reflective patches 20, the size and the relative position of which are known, detectable by an infrared camera. The shape of the patches is not limiting. Thus, said patches could be replaced by reflective elements having any other appropriate shape, for example beads.

10 In an alternative manner, the reflective patches could be replaced by a chart formed of a two-coloured pattern of known geometry.

According to other embodiments, the reflective patches could be replaced by diodes, electromagnetic coils, or any other appropriate localization means, such as IMUs (inertial measurement units), accelerometers, gyroscopes, etc.

15 As illustrated in figure 1, the device 1 comprises:

- an intra-oral portion 10 intended to be maintained against the outer face of the teeth of the lower jaw (not represented),

- an extra-oral portion 12 (more clearly visible in figures 2 to 5) comprising an attachment element for the marker 2,

20 - a connecting portion 11 making it possible to connect the intra-oral portion 10 to the extra-oral portion 12.

In a particularly advantageous manner, the whole of the three parts 10, 11, 12 is integrally formed by moulding of a biocompatible thermoplastic material.

25 For example, this material may be polyamide, polypropylene, PEEK (non-exhaustive list).

The device 1 is typically single-use and may thus be discarded after use.

With a view to its use, and depending on potential regulatory requirements, the mandibular attachment device may be supplied sterilised in a sealed envelope protecting it from any external contamination.

30 Figures 2 to 5 illustrate views of the mandibular attachment device without the marker.

The intra-oral portion 10 has a general U-shape.

The material and the thickness of the intra-oral portion are chosen to have a certain flexibility in a direction of moving apart or coming closer of the legs of the U in their plane.

35 Thus, the two legs 100 may be moved apart with respect to their initial position to be inserted in the mouth of the individual without rubbing against the teeth or the gums, then released once they have been correctly positioned.

At rest, that is to say before insertion in the mouth of the individual, the width L of the intra-oral portion is defined as being the maximum distance between the two legs of the U.

Preferably, the width of the intra-oral portion at rest is slightly less than the average width of the jaw of the individual (defined as being the distance between the outer surfaces of the molars of the lower jaw), such that once inserted into the mouth of the patient, the elasticity of the legs 100 exerts a slight compressive force on the teeth, in order to ensure the intra-oral portion is maintained correctly.

According to an optional but advantageous embodiment, the end of the legs of the U is made divisible by the presence of one or more notches 101 which define one or more detachable segments 102. Thus, one or more of said detachable segments may be removed until a length of the legs 100 is obtained adapted to the length of the jaw of the individual. The length of said segments 102 (distance between two adjacent notches 101) is typically of the order of 5 to 10 mm. The notches 101 may extend from the lower face or the upper face of the legs 100; they may also extend from two faces opposite each other, as is the case in figures 1 to 5. The depth of the notches 101 (or the sum of the depths in the case of opposite notches) is typically of the order of half of the height h of each leg.

In an advantageous manner, the mechanical strength of the intra-oral portion 10 on the jaw of the patient is ensured at least in part by a biocompatible adhesive (not represented) deposited between the surface of the teeth and the inner face of the intra-oral portion. Such a biocompatible adhesive is frequently used in the dentistry field.

Furthermore, the inner face 103 of the intra-oral portion, that is to say the face intended to come into contact with the teeth, may have a certain roughness. For example, a part made by 3D printing (using the so called SLS (selective laser sintering) technique) has an appropriate roughness. In the case of a part made by moulding, the injection mould may undergo a treatment, for example a sanding or a chemical etching, conferring on it a non-smooth surface state. This roughness makes it possible to improve the mechanical strength of the adhesive vis-à-vis the inner face 103.

On the other hand, the inner face 103 of the intra-oral portion may be provided with notches 104. Said notches are arranged in such a way as to be located facing parts in relief on the outer surface of the teeth when the device is in place in the mouth of the individual. The notches 104 thus fulfil a function of blocking the intra-oral portion, notably in the antero-posterior direction, which stabilise the device in the mouth.

In a particularly advantageous manner, the height h of the intra-oral portion is chosen sufficiently low (typically less than the average height of the teeth) in order not to go beyond the plane formed by the upper surface of the teeth of the lower jaw when the device is in place in the mouth of the individual. For example, the height h is of the order to 5 mm.

Thus, the intra-oral portion does not interfere with the mandibular kinematics (clenching of the teeth, chewing movements and others).

The extra-oral portion 12 has for its part an attachment element 120 for a marker.

In the example illustrated in the appended figures, the marker 2 is attached by snap coupling on the extra-oral portion 12. To this end, as illustrated in figure 6, the mandibular marker 2 comprises, on its inner face (i.e. opposite to the reflective patches), two lugs 21, 22 arranged one above the other (considering the position of the marker when it is in place on the individual). The attachment element 120 comprises two recesses 121, 122 separated by an elastic tab 123. To put in place the marker 2 on the attachment device 1, the upper lug 21 is firstly engaged in the recess 121, then the lower lug is engaged in the recess 122, this engagement causing a slight deformation of the tab 123 rearwards (that is to say on the side opposite the reflective patches). The marker is thus maintained on the extra-oral portion 12 by engagement of the lugs 21, 22 in the recesses 121, 122 and by a pressure force exerted by the deformed tab 123.

The assembly of the marker 2 on the attachment device is advantageously carried out once the attachment device has been put in place in the mouth of the patient and attached using the aforesaid biocompatible adhesive. Thus, the marker does not hinder this putting in place operation.

Thanks to the attachment mechanism described above, the marker can be manipulated with a single hand by the practitioner to be put in place on the extra-oral portion of the device.

Furthermore, the force required to put in place the marker on the extra-oral portion is very low, such that it does not affect the mechanical strength of the attachment device vis-à-vis the mandible.

In a particularly advantageous manner, the attachment element 120 further comprises two lateral elastic fins 124, which are deformed during the putting in place of the mandibular marker on the extra-oral portion 12. Said fins then exert a pressure force on the inner face of the marker, which further stabilises its attachment.

It will be noted that the putting in place of the marker is particularly facilitated when the lugs and recesses are arranged one above the other in the use position of the device, because the upper recess is easily accessible to the practitioner. However, a similar architecture with an alignment of the recesses and the tab in a horizontal plane, or according to any inclination, could also be implemented without however going beyond the scope of the present invention. For example, the extra-oral portion could comprise a right recess and a left recess aligned in a horizontal plane and, for the assembly, the marker should be presented in front of the extra-oral portion with the lugs aligned along a horizontal plane, in

order to enable the engagement of the lugs in the recesses and the deformation of the tab in a horizontal plane.

The extra-oral portion is designed to be sufficiently rigid to support the weight of said marker without being deformed.

5 Preferably, the mode for attaching the marker 2 on the extra-oral portion 12 is chosen so as not to require any tool. For example, the extra-oral portion may have an element enabling the snap connection of the marker, a quarter turn type attachment, or even a magnetic force, etc. In the latter case, the extra-oral portion and the marker are respectively provided with a magnet and/or an element made of ferrous material intended to cooperate
10 with the magnet.

In a particularly advantageous manner, the marker can be detached from the attachment device.

According to an embodiment, the attachment for the marker is moreover reproducible, that is to say that each time that the marker is put in place on the device, the position of the
15 marker with respect to the device is identical.

To this end, the attachment element 120 provided on the extra-oral portion 12 comprises means for guiding and/or abutting the marker.

According to a less preferred embodiment, the marker could form an integral part of the extra-oral portion.

20 When the device 1 is in place in the mouth of the individual, the extra-oral portion 12 is advantageously situated below the plane of the lips of the individual (the marker 20 being able for its part to go beyond this plane).

For reasons of stability of the device, said device is substantially symmetrical with respect to the antero-posterior plane of the individual.

25 The connecting portion 11 between the intra-oral 10 and extra-oral 12 portions is like a bridge clamp extending from the central region of the intra-oral portion 10. This bridge clamp has a first section 110 extending towards the upper jaw, a second section 111 extending through the lips and a third section 112 for connecting to the extra-oral portion 12.

30 The shape and the dimensions of the connecting portion are chosen so that, when the device is in place in the mouth of the individual, the second section 111 extends to the level of the plane of the lips, without exerting pressure on the lips. The device 1 remains immobile even in the event of swallowing.

35 Furthermore, the connecting portion 11 is designed to be sufficiently rigid so as not to deform when the marker 20 is attached to the extra-oral portion 12.

The device 1 and the marker 2 form part of a localization system in which they are associated with a camera, notably an infrared camera in the case of a marker provided with reflective patches.

5 To record the mandibular kinematics of an individual, the intra-oral portion is attached in contact with the teeth of the lower arch of the individual, then the marker is attached to the extra-oral portion.

10 The individual is also equipped with a forehead support also bearing a localization marker according to the same technology as the mandibular marker. Optionally, it is possible to do without such a forehead support by equipping the upper jaw with an attachment device similar to that which has just been described, with shapes and dimensions adapted to this jaw.

The putting in place of these markers on the individual is naturally carried out in a non-invasive manner.

15 The camera is placed opposite the patient, such that the forehead marker and the mandibular marker are permanently within his field of vision.

The individual then carries out a certain number of mandibular movements (chewing, etc.) according to the recommendations of the practitioner.

The camera detects and records the relative displacements of the markers.

20 After the acquisition, this recording is applied to digital models of the dental arches of the individual, which makes it possible to animate them.

Patentkrav

1. Indretning til lokalisering af underkæben hos et individ, omfattende:

5 (a) en markør (2), der omfatter en indvendig side, som er forsynet med to fastgørelsestapper (21, 22), og

(b) en indretning (1) til fastgørelse af nævnte markør (2) til individets underkæbe, omfattende:

- en intra-oral del (10) med en generel U-form, der er tilpasset til at komme i kontakt med den udvendige side af underkæbens tænder,

10 - en ekstra-oral del (12) med et fastgørelseselement (120) til markøren (2),

- en forbindelsesdel (11), der forbinder den intra-orale del og den ekstra-orale del,

15 hvor fastgørelseselementet (120) omfatter to udsparinger (121, 122), der hver er tilpasset til at modtage en tap (21, 22) af markøren (2), hvor udsparingerne (121, 122) er adskilt af en flig (123), der er indrettet til deformerer elastisk, når en (22) af tappene er i indgreb i en respektive udsparing (122), hvor markøren (2) er fastgjort til den ekstra-orale del (12) af fastgørelsesindretningen ved indgreb af hver tap (21, 22) i en respektive udsparing (121, 122), hvor den elastisk deformede flig (123) udøver en trykkraft på en (22) af tappene.

20

2. Indretning ifølge krav 1, hvor fastgørelseselementet (120) yderligere omfatter to laterale finner (124), der er indrettet til deformerer elastisk, når hver tap (21, 22) er i indgreb med en respektive udsparing (121, 122) for at udøve en trykkraft på markørens indvendige side (2).

25

3. Indretning ifølge et af kravene 1 eller 2, hvor den intra-orale del (10) er fleksibel i U-planet.

4. Indretning ifølge et af kravene 1 til 3, hvor den side (103) af den intra-orale del (10), der vender mod tænderne, har en ru overflade.
- 5 5. Indretning ifølge et af kravene 1 til 4, hvor den side (103) af den intra-orale del (10), der vender mod tænderne omfatter, omfatter mindst ét indhak (104), som er indrettet til at gå i indgreb med et fremspring af tænderne i underkæben.
- 10 6. Indretning ifølge et af kravene 1 til 5, hvor den intra-orale del (10) ved sine ender er forsynet med delelige segmenter (102).
7. Indretning ifølge et af kravene 1 til 6, hvor fastgørelseselementet (120) omfatter midler til styring og / eller anlæg af markøren (2).
- 15 8. Indretning ifølge et af kravene 1 til 7, hvor fastgørelseselementet (120) er konfigureret til at muliggøre demontering af markøren (2).
- 20 9. Indretning ifølge et af kravene 1 til 8, hvor formen og dimensionerne af forbindelsesdelen (11) vælges således, at når fastgørelsesindretningen (1) er på plads i individets mund, vil en sektion (111) af nævnte forbindelsesdel strække sig i det væsentlige i planet for læbernes lukning.
- 25 10. Indretning ifølge et af kravene 1 til 9, hvor den intra-orale del (10), den ekstra-orale del (12) og forbindelsesdelen (11) er udført i ét stykke.
11. Indretning ifølge et af kravene 1 til 10, hvor den intra-orale del (10), den ekstra-orale del (12) og forbindelsesdelen (11) er dannet af et biokompatibelt materiale.

12. Indretning ifølge et af kravene 1 til 11, hvor markøren (2) omfatter et antal reflekterende prikker (20).

5 **13.** Lokaliseringssystem, som omfatter et kamera og en lokaliseringsindretning ifølge et af kravene 1 til 12, især et infrarødt kamera i tilfælde af en markør, der er forsynet med reflekterende prikker.

10 **14.** Fremgangsmåde til registrering af underkæbe-kinematik af et individ ved hjælp af lokaliseringssystemet ifølge krav 13, hvor markøren (2) er fastgjort på tænderne i individets underkæbe ved hjælp af fastgørelsesindretningen (1), en anden markør, der er forsynet med et antal reflekterende prikker, er fastgjort på individets pande, og de relative forskydninger af nævnte markører under underkæbens bevægelser, der foretages af individet, registreres med det infrarøde kamera.

15

15. Fremgangsmåde ifølge krav 14, hvor der for at fastgøre markøren (2) på fastgørelsesindretningen (1) vises den indvendige side af markøren, som er forsynet med to fastgørelsestapper (21,22) over for den ekstra-orale del af indretningen, er en første tap (21) i indgreb med en første udsparring (121), derefter en anden tap (22) i en anden udsparring (122), mens den elastisk deformerer fligen (123), så fligen (123) udøver en trykkraft på den anden tap (22).

20

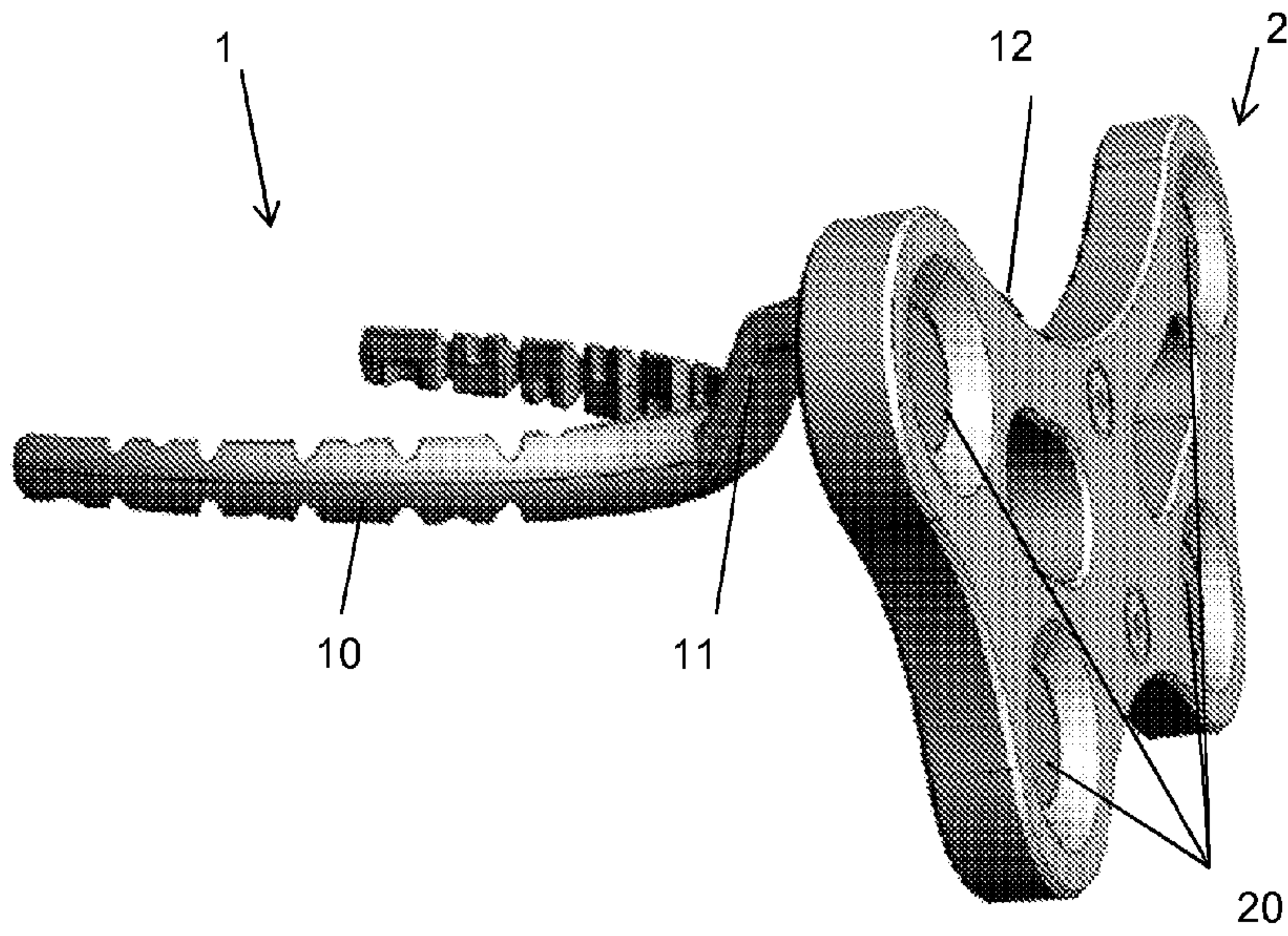

FIGURE 1

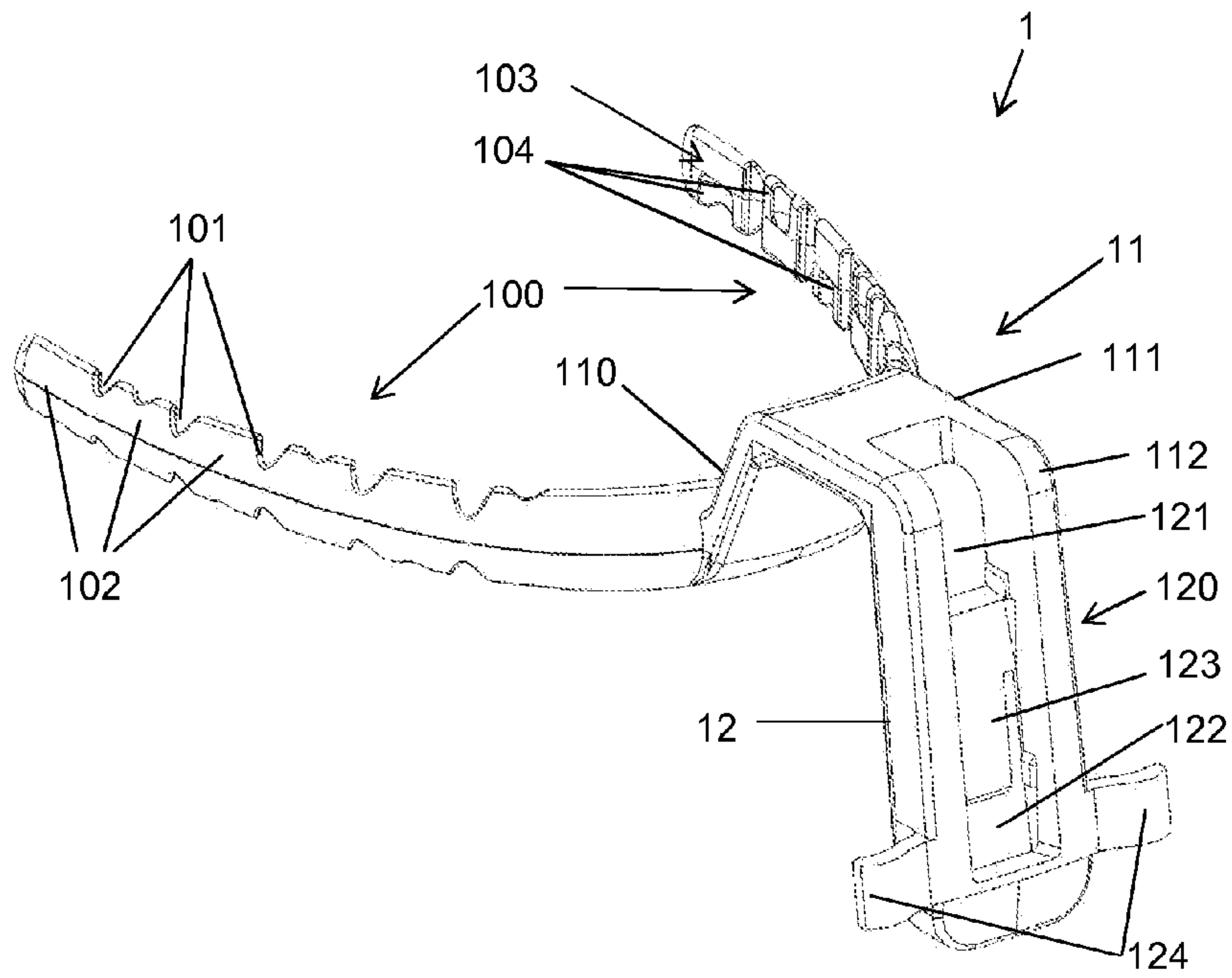

FIGURE 2

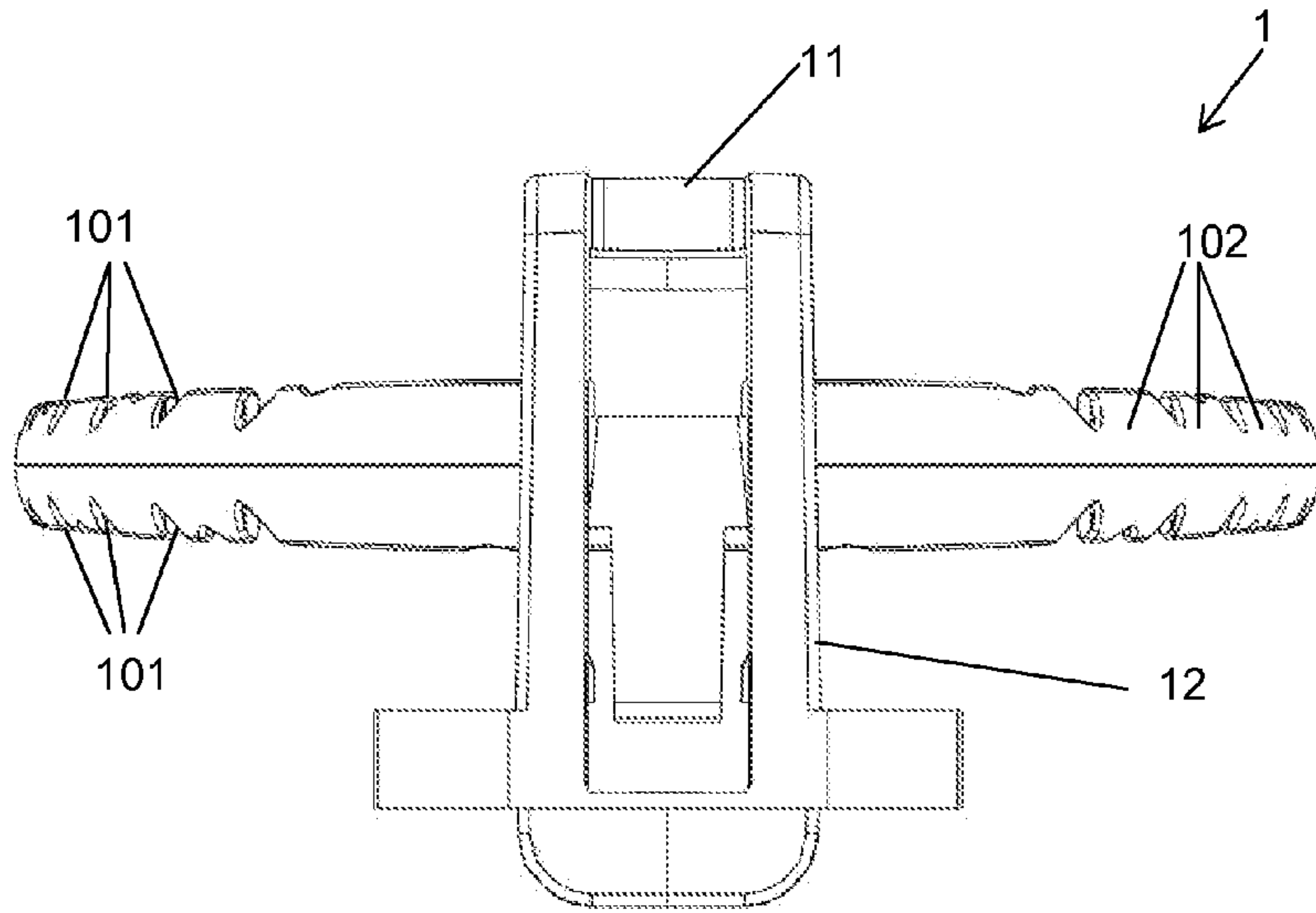

FIGURE 3

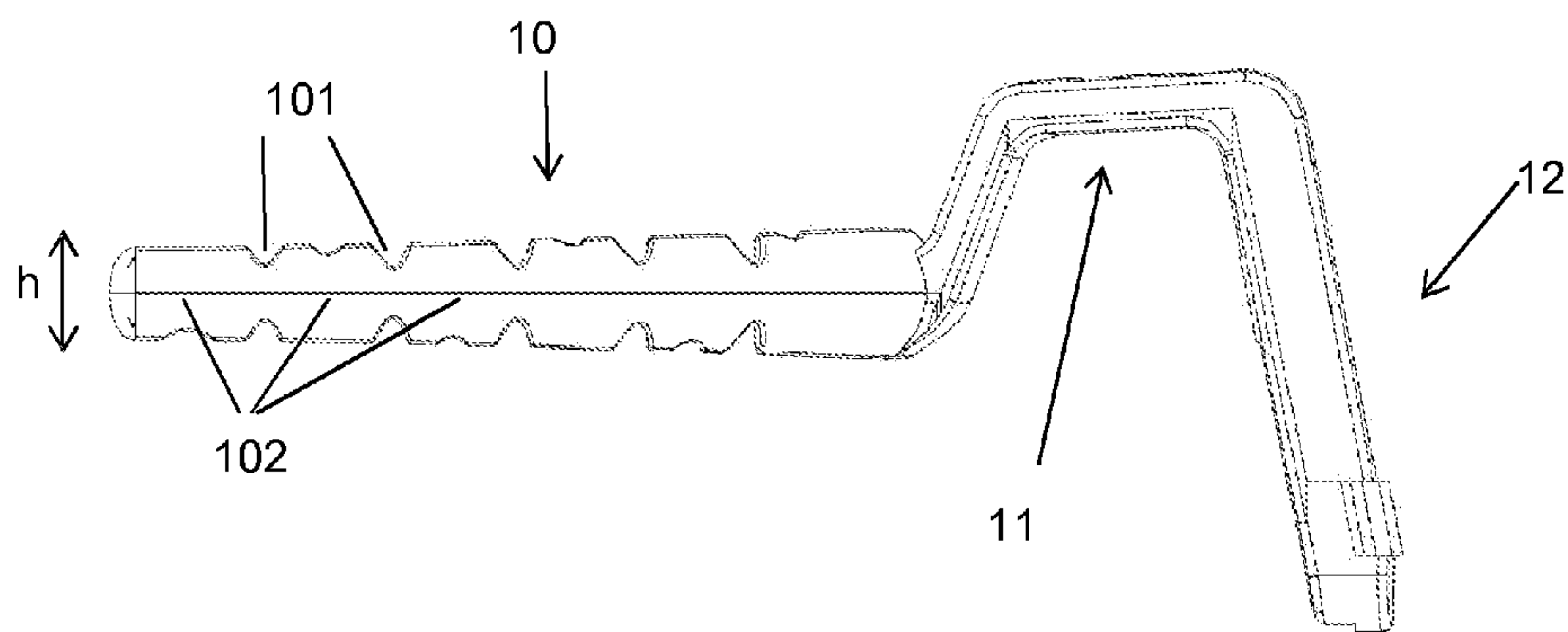

FIGURE 4

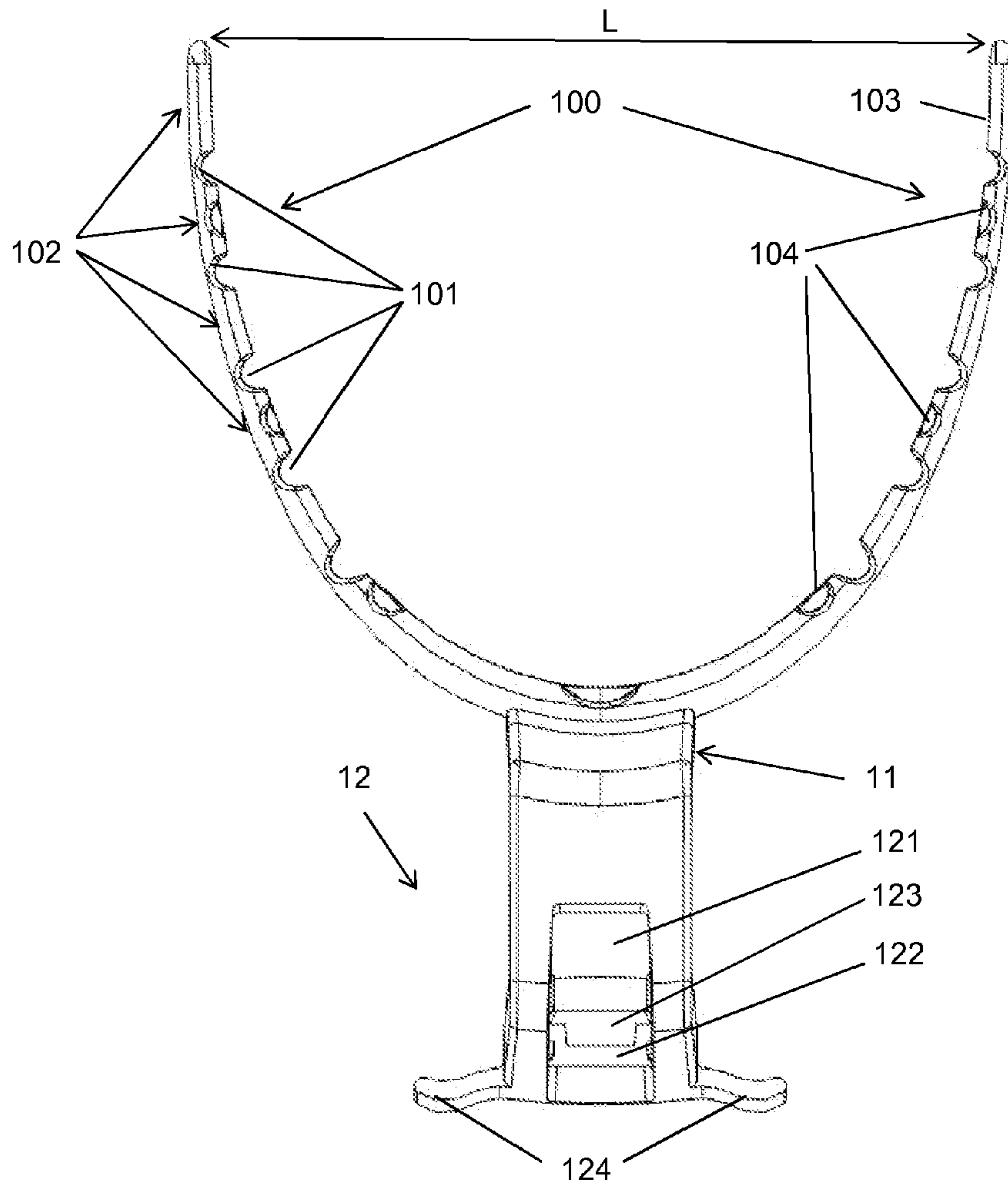

FIGURE 5

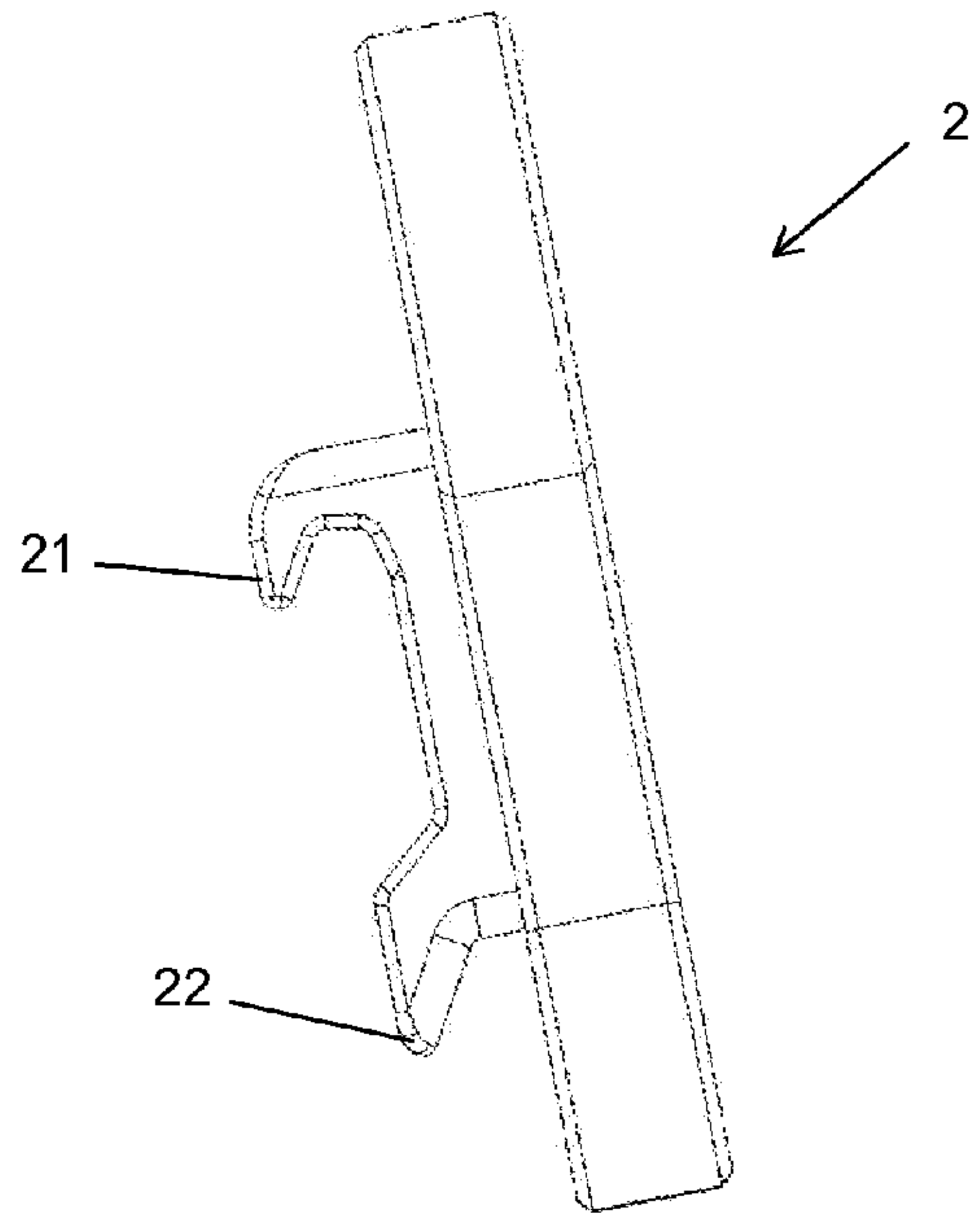

FIGURE 6