



US00D397306S

United States Patent [19]

[11] Patent Number: Des. 397,306

Ross, Jr.

[45] Date of Patent: **Aug. 25, 1998

[54] GAUGE DIAL

[75] Inventor: Herbert G. Ross, Jr., Argyle, Tex.

[73] Assignee: Rochester Gauges, Inc., Dallas, Tex.

[**] Term: 14 Years

[21] Appl. No.: 73,004

[22] Filed: Jun. 27, 1997

[51] LOC (6) Cl. 10-04

[52] U.S. Cl. D10/103

[58] Field of Search D10/101, 102, D10/103, 96; 73/290 R. 305, 313, 317, 318; 116/204, 284, 56-62.4, 227, 264, 265, 271, DIG. 7, DIG. 20

[56] References Cited

U.S. PATENT DOCUMENTS

D. 313,949	1/1991	Fekete	D10/57
D. 363,888	11/1995	Williamson	D10/96
2,836,144	5/1958	Morphis	D10/103
2,992,560	7/1961	Morgan et al.	73/317
3,739,641	6/1973	Taylor et al.	73/313

OTHER PUBLICATIONS

Rochester Gauges, Inc., EZ-Read TwinSite™ Sender Installation/Conversion Technical Data Sheet DS-923, 4 pages.
 Rochester Gauges, Inc., Senior EZ-Read TwinSite™ Sender for Industrial Service Technical Data Sheet TS002, Mar. 25, 1994, 2 pages.

Rochester Gauges, Inc., Junior EZ-Read TwinSite™ Sender for Industrial Service Technical Data Sheet TS003, Mar. 25, 1994, 2 pages.

Rochester Gauges, Inc., Voltage Divider TwinSite™ Sender Technical Data Sheet VD001, Jan. 21, 1994, 2 pages.

Rochester Gauges, Inc., TwinSite™ Switch Technical Data Sheet VD002, Jan. 21, 1994, 2 pages.

Rochester Gauges, Inc., Junior EZ-Read TwinSite™ Two-Terminal Sender, May 27, 1992, 2 pages.

Rochester Gauges, Inc., Various Gauges, Aug. 1993, one page.

Rochester Gauges, Inc., Industrial Liquid Level Gauges, Specifications Brochure, 12 pages.

Primary Examiner—Antoine Duval Davis
Attorney, Agent, or Firm—Sidley & Austin

[57] CLAIM

The ornamental design for a gauge dial, as shown and described.

DESCRIPTION

FIG. 1 is a perspective view of a first embodiment of the gauge dial;
 FIG. 2 is a front view of the gauge dial of FIG. 1;
 FIG. 3 is a side view of the gauge dial of FIG. 1;
 FIG. 4 is a back view of the gauge dial of FIG. 1;
 FIG. 5 is the opposite side view of the gauge dial of FIG. 1;
 FIG. 6 is a top view of the gauge dial of FIG. 1; and
 FIG. 7 is a bottom view of the gauge dial of FIG. 1.
 The broken line showing is for illustrative purposes only and forms no part of the claimed design.

1 Claim, 1 Drawing Sheet

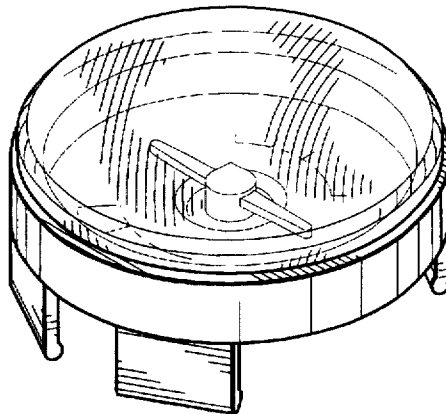

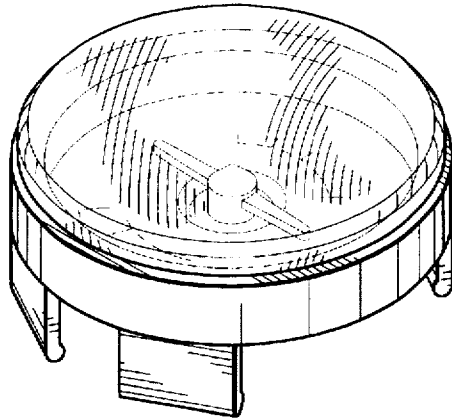

FIG. 1

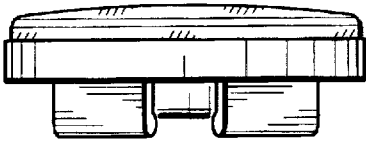

FIG. 2

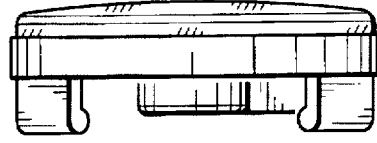

FIG. 3

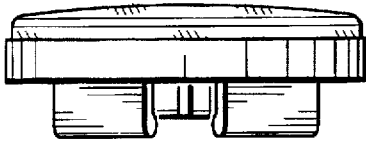

FIG. 4

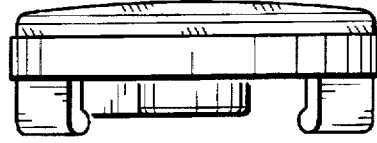

FIG. 5

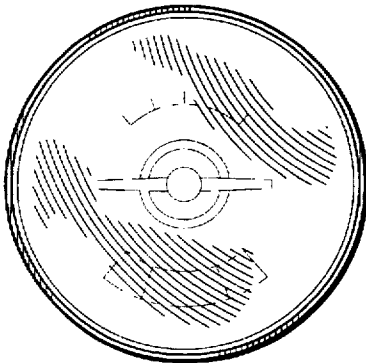

FIG. 6

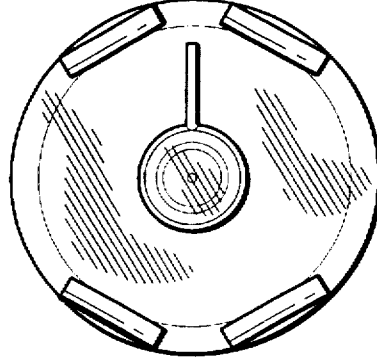

FIG. 7