

Feb. 7, 1928.

1,658,337

J. S. JAMMER

CARRIER WAVE SIGNALING SYSTEM

Filed June 21, 1924

3 Sheets-Sheet 1

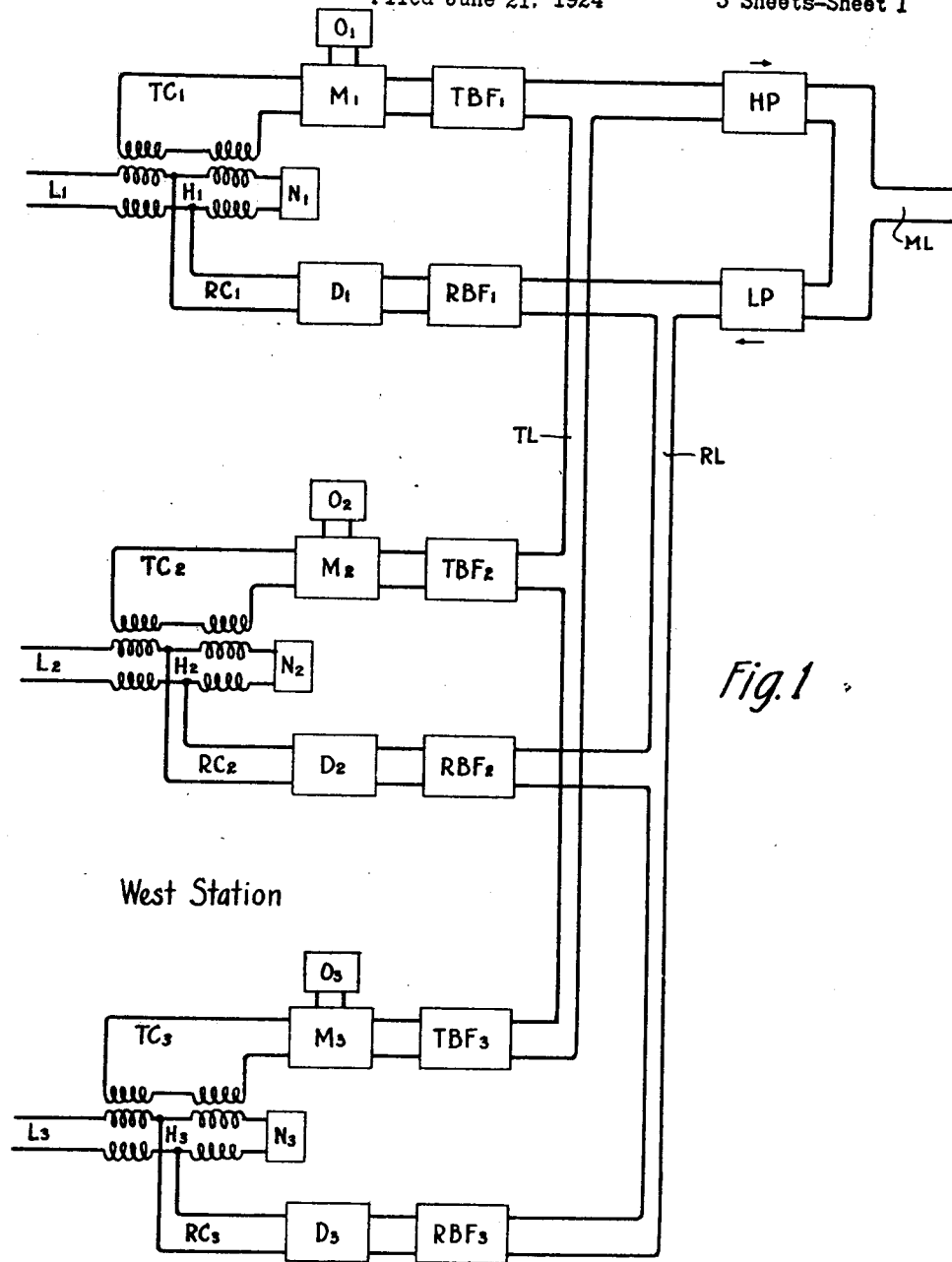

Fig. 1

Inventor:
Jacob S. Jammer
by *E. Adams* Atty

Feb. 7, 1928.

J. S. JAMMER

1,658,337

CARRIER WAVE SIGNALING SYSTEM

Filed June 21, 1924

3 Sheets-Sheet 3

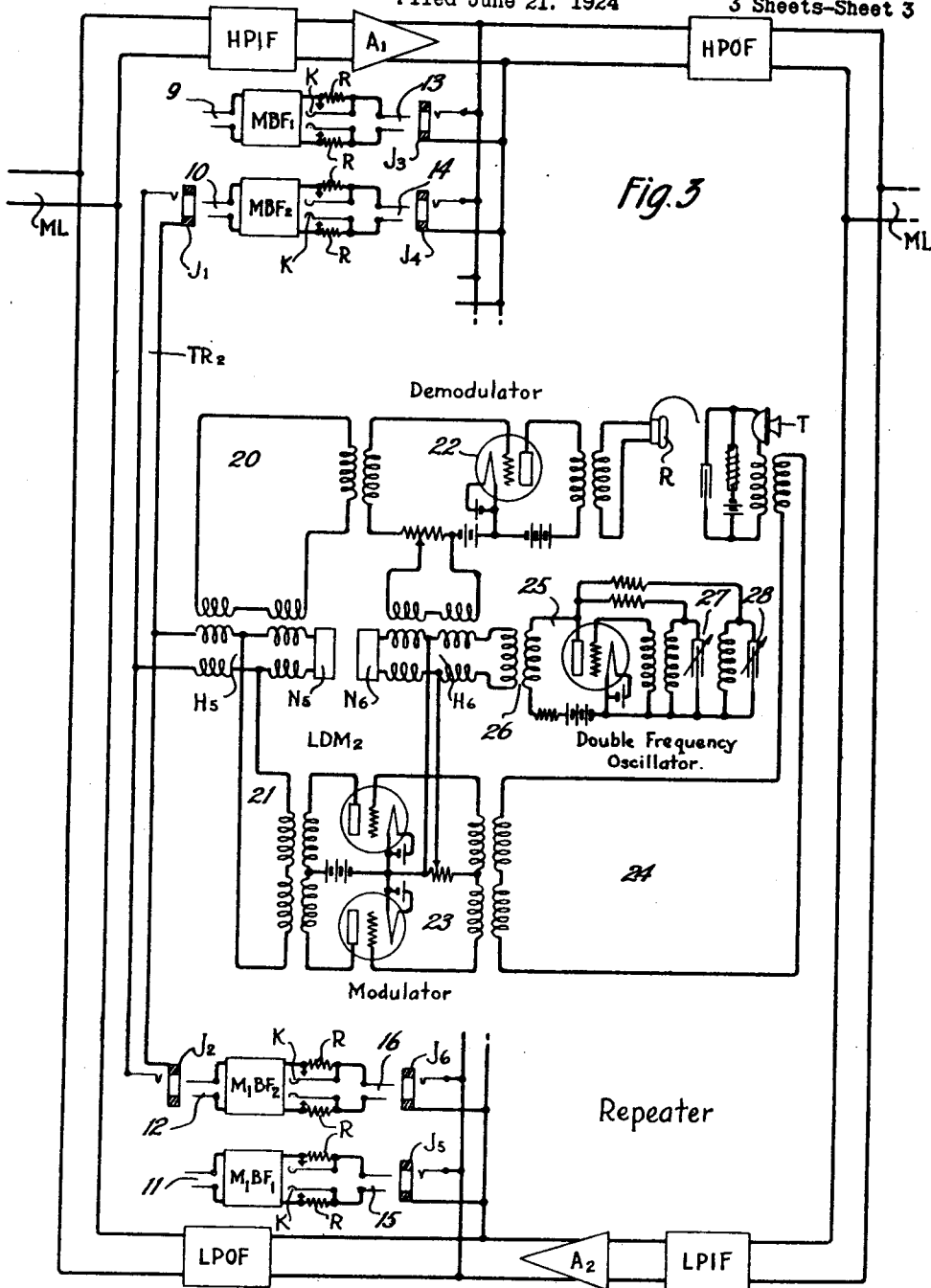

Inventor:
Jacob S. Jammer
by *E. W. Adams*, Atty

UNITED STATES PATENT OFFICE.

JACOB S. JAMMER, OF NEW YORK, N. Y., ASSIGNOR TO WESTERN ELECTRIC COMPANY, INCORPORATED, OF NEW YORK, N. Y., A CORPORATION OF NEW YORK.

CARRIER-WAVE SIGNALING SYSTEM.

Application filed June 21, 1924. Serial No. 721,337.

This invention relates to carrier wave signaling systems, and particularly to means for monitoring and talking over such systems at intermediate stations.

5 An object of the invention is to provide means for monitoring and talking over any channel of a carrier wave signaling system.

A related object of the invention is to facilitate the operation and maintenance of such a system.

10 A particular advantage of the invention is that it may readily be applied to a standard carrier wave signaling system without otherwise altering the system.

15 The invention provides means for monitoring and talking on any channel of a carrier system at repeater stations, the carrier current being selected from the line by means of band filters which may be connected across the output of the repeater amplifiers, this current being utilized to permit the repeater attendant to listen in on the carrier channels or to use any channel as a talking circuit to other stations.

25 The invention will be described as applied to a multiplex carrier current telephone system, although it will be understood that it may also be applied to other signaling systems.

30 In the drawings:

Fig. 1 is a diagrammatic view illustrating a terminal station of a carrier telephone system.

35 Fig. 2 is a diagrammatic view of a carrier telephone repeater station embodying the invention.

Fig. 3 is a diagrammatic view illustrating a modification of the system of Fig. 2.

40 Reference will first be made to Figs. 1 and 2, which, when placed side by side with Fig. 1 at the left, represent the west terminal station and a mid-line repeater of a carrier telephone system interconnected by the multiplex line ML.

45 The usual east terminal station, which is identical to the west terminal station shown in Fig. 1 is omitted for the sake of simplifying the showing. A carrier telephone system of this type, including both west and east terminal stations, as well as an intermediate repeater station, is illustrated in Fig. 24 of an article entitled "Carrier current telephony and telegraphy" by Messrs. Colpitts and Blackwell, published

in the Transactions of the American Institute of Electrical Engineers, vol. 40, 1921.

The terminal apparatus at the west station comprises a plurality of transmitting channels TC_1 , TC_2 and TC_3 connected through a common transmitting circuit TL to the main line ML, and a plurality of receiving channels RC_1 , RC_2 and RC_3 connected through a common receiving circuit RL to the main line ML.

Carrier currents are utilized for transmission over the line ML and are grouped as to their frequencies, the higher frequencies, as a group, being used for transmission from west to east and the lower frequencies, as a group, being used for transmission from east to west.

A high pass grouping filter HP is paired with a low pass grouping filter LP at the terminal stations. These filters serve to separate the directional groups of carrier waves to the respective terminal transmitting and receiving circuits. These filters and each of the other filters shown throughout the system may be designed in accordance with the principles set forth in the United States Patent to Campbell, No. 1,277,113, issued May 22, 1917. Specific types of both high and low pass filters are shown, for example, in Fig. 11 of the Campbell patent.

Low frequency lines L_1 , L_2 and L_3 which may be telephone lines or other types of signaling lines, are associated with channels TC_1-RC_1 , TC_2-RC_2 and TC_3-RC_3 respectively, for simultaneous and independent communication over the line ML with corresponding similar lines at the east station (not shown).

The low frequency lines are provided with balancing artificial lines or networks N_1 , N_2 and N_3 , respectively, and with differential repeating coils H_1 , H_2 and H_3 , commonly known as hybrid coils, for enabling independent transmission in the two directions between the line and the high frequency terminal apparatus.

50 Transmitting channel TC_1 includes a modulator M_1 and a band filter TBF_1 . Similarly, transmitting channel TC_2 includes a modulator M_2 and a band filter TBF_2 , while channel TC_3 includes a modulator M_3 and a band filter TBF_3 .

Receiving channel RC_1 includes a demodulator D_1 and a band filter RBF_1 . Similar-

ly, channel RC_2 includes a demodulator D_2 and a band filter RBF_2 , while channel RC_3 includes a demodulator D_3 and a band filter RBF_3 .

5 The modulators associated with the various transmitting channels throughout the system may be of any well known type, such as that disclosed in the United States patent to van der Bijl, No. 1,350,752, issued
10 August 24, 1920. The various demodulators may be of the well known vacuum tube detector type shown in Fig. 42 of the Colpitts and Blackwell article, supra.

The mid-line repeater illustrated in Fig. 2
15 is connected to the multiplex line ML intermediate the terminal stations in the usual manner shown in detail in Fig. 24 of the Colpitts and Blackwell article. This repeater may be of any suitable type, such as
20 that disclosed in the United States Patent to Raibourn, No. 1,413,357, issued April 18, 1922.

The upper and lower branches of the repeater contain amplifiers A_1 and A_2 , respectively which may be of the highly evacuated three-element electron discharge type for amplifying the current supplied to the
25 respective branches. The upper branch is for repeating currents from west to east and includes a high pass input filter HPIF and high pass output filter HPOF; and the lower branch for repeating currents from east to west includes a low pass input filter LPIF and a low pass output filter LPOF.
30 For further details of the arrangement of repeater filters and amplifiers reference may be had to the Raibourn patent, supra.

The carrier system outlined above is of the type in which the carrier current is
35 transmitted continuously, as distinguished from the type in which the carrier is suppressed from transmission. A system of this general character is described in connection with Fig. 42 of the Colpitts and
40 Blackwell article, supra.

In this system, carrier currents of the frequency assigned to channel TC_1 are supplied from a source O_1 to the modulator M_1 , wherein they are modulated by voice frequency currents or other signaling currents from the low frequency line L_1 . Carrier
45 source O_2 and O_3 of the other respective carrier frequencies are similarly associated with modulators M_2 and M_3 , respectively.

50 The various band filters associated with the terminal transmitting and receiving channels are so designed that they will transmit bands of frequencies including the carrier assigned to the respective channels as well as one of the side bands, either the
55 upper or lower as desired, and will suppress from transmission frequencies lying outside of such band.

Voice frequency currents originating, for
60 instance, in the low frequency line L_1 at the

west station pass through the associated hybrid coil H_1 into the modulator M_1 in the transmitting channel TC_1 . There is likewise fed into the modulator the carrier current from the oscillator O_1 as described
65 above. Of the components of modulation appearing in the output circuit of the modulator M_1 , the transmitting band filter TBF_1 suppresses all except one side band, for example the upper side band, and the carrier,
70 which it transmits or passes into the common transmitting circuit TL. The currents so transmitted from channel TC_1 and the other transmitting channels then pass through the high pass grouping filter HP to the multiplex line ML. The currents thus transmitted from the west station are selected by the repeater filter HPIF, are passed through the amplifier A_1 and thence through filter HPOF to the line ML. The incoming currents at the east station (not shown) are received in the same manner as incoming currents at the west station. For example, currents transmitted from the east station are picked up at the west station by the low pass grouping filter LP and are passed through the common receiving circuit RL and the respective receiving band filters RBF_1 , RBF_2 or RBF_3 , as the case may be. Currents transmitted through band filter RBF_1 ,
75 for example, are demodulated in the demodulator D_1 , and the voice frequency components of demodulation appearing in receiving channel RC_1 are transmitted through hybrid coil H_1 to the low frequency line L_1 .
80
85
90
95
100

As shown in Fig. 2, the invention provides means whereby the attendant at the repeater station may listen in on any carrier channel without interrupting the transmission of messages between the terminal stations. Means are also provided whereby the repeater attendant may use any channel of the system as a talking circuit to other stations.

A loop demodulator-modulator circuit LDM_1 is associated with a common transmitting and receiving circuit TR_1 through the balanced three-winding repeating or hybrid coil H_4 , the other side of which is connected to the balancing network N_4 .
110
115

The circuit LDM_1 comprises a receiving channel 5 and a transmitting channel 6 made conjugate by the hybrid coil H_4 . The receiving channel 5 includes a demodulator 7, and the transmitting channel 6 includes a modulator 8. An operator's set, comprising a transmitter T, receiver R and appropriate connections therefor, is associated with the output of the demodulator 7 and with the input of the modulator 8.
120
125

The circuit TR_1 terminates in jacks J_1 and J_2 . A plurality of monitoring band filters MBF_1 , MBF_2 , M_1BF_1 and M_1BF_2 are provided for separating a desired channel to be used for monitoring or talking from the
130

rest of the channels. The band filters MBF_1 and MBF_2 are adapted to be associated with the circuit TR_1 by means of plugs 9 and 10, respectively, cooperating with the jack J_1 . Similarly, the band filters M_1BF_1 and M_1BF_2 may be associated with the circuit TR_1 by means of plugs 11 and 12, respectively, cooperating with the jack J_2 . Channel taps terminating in one or more jacks J_3, J_4 and one or more jacks J_5, J_6 , etc. are provided at the repeater station in the output circuits of amplifiers A_1 and A_2 , respectively. Band filters MBF_1 and MBF_2 may be associated with jacks J_3 and J_4 , respectively, by means of plugs 13 and 14, while band filters M_1BF_1 and M_1BF_2 may be associated with jacks J_5 and J_6 , respectively, by means of plugs 15 and 16.

It will be understood that the band filters MBF_1, MBF_2, M_1BF_1 and M_1BF_2 are each designed to transmit frequencies of a range assigned to a particular channel of the system. For example, filter MBF_1 will pass a frequency range identical to that assigned to transmitting band filter TBF_1 at the west terminal station, while band filter MBF_2 will pass frequencies of the range assigned to transmitting filter TBF_2 . Similarly, band filter M_1BF_1 passes frequencies of the range assigned to terminal filter RBF_1 and band filter M_1BF_2 passes frequencies of the range assigned to terminal filter RBF_2 , and so forth.

If the repeater attendant desires to monitor on one of the channels, for example, on the channel associated with low frequency line L_1 , he will insert plugs 9 and 13 into jacks J_1 and J_3 , respectively, and will also insert plugs 11 and 15 into jacks J_2 and J_5 , respectively. This connects band filters MBF_1 and M_1BF_1 across the output of amplifiers A_1 and A_2 , respectively. The resistances R in circuit with the band filters MBF_1 and M_1BF_1 offer a high impedance to the output currents of amplifiers A_1 and A_2 so as to introduce only a small loss and a resultant small change in the overall equivalent of the channel. The currents passing through filters MBF_1 or M_1BF_1 cannot pass to the opposite branch of the repeater circuit due to the fact that filter MBF_1 does not pass frequencies of the range assigned to filter M_1BF_1 , and vice versa. The monitoring currents pass through the hybrid coil H_4 to the receiving channel 5, and thence to the demodulator 7 where they are demodulated, the voice frequency components being heard in the attendant's telephone receiver R , and the high frequency wave components passing through modulator 8, hybrid coil H_4 , circuit TR_1 , and back through the respective filters MBF_1 and M_1BF_1 to the line.

When the repeater attendant desires to talk to another station, he operates key K

in circuit with the band filters MBF_1 and M_1BF_1 , thus removing the resistances R from the circuit and allowing more carrier current to pass into the demodulator 7. This introduces a greater loss in the channel output to the line, but this loss is compensated for by the regenerative gain introduced by the loop demodulator and modulator hybrid circuit LDM_1 . The currents passing through band filters MBF_1 and M_1BF_1 to the demodulator 7 are demodulated, the voice frequency components being heard as before in the attendant's telephone receiver R , and the carrier components passing on to the modulator 8 where they are modulated by the voice frequency currents from the attendant's transmitter T . The currents so modulated are passed through the hybrid coil H_4 to the circuit TR_1 and thence through the particular band filter MBF_1 or M_1BF_1 designed to pass currents of those frequencies. It will thus be seen that when the attendant talks, the sideband currents are transmitted to both the east line and the west line and the attendant is able to talk to other repeaters or to either terminal station.

A modification of the invention is shown in Fig. 3, which illustrates a line repeater of a carrier telephone system in which the carrier is suppressed from transmission.

In a carrier system of this type the carrier wave of each channel is suppressed from transmission when no signals are being sent, and when signals are being transmitted the modulation components of the modulated wave are sent over the line, but no unmodulated components of the carrier wave are transmitted. In order to reproduce the signal from modulated waves of this character, it is necessary that a carrier wave of substantially the same frequency as that suppressed at the transmitter should be supplied to the demodulator at the receiver. A system of this general character is described in connection with Fig. 49 of the Colpitts and Blackwell article, supra. The terminal stations associated with the opposite ends of the multiplex line ML of Fig. 3 may be identical with that shown in Fig. 1 except that oscillators should be associated with the demodulators D_1, D_2 , etc., in the same manner in which oscillators O_1, O_2 , etc. are associated with modulators M_1, M_2 , etc., and the modulators employed at the terminal stations should be of the balanced type shown in Fig. 49 of the Colpitts and Blackwell article. These balanced modulators, which are employed for the purpose of suppressing the carrier from transmission may be of the specific type shown in the U. S. patent to Carson, No. 1,343,306, issued June 15, 1920.

Since, in the carrier suppression system the carrier is suppressed at the terminal station, means are provided at the repeater sta-

tion for locally generating carrier waves for both the modulator and the demodulator of the monitoring circuit. For this purpose a double frequency oscillator is used. This oscillator is designed to generate simultaneously the two carriers required for east and west transmissions.

The loop demodulator-modulator circuit LDM₂ of Fig. 3 comprises a receiving channel 20 and a transmitting channel 21 which are made conjugate by means of a hybrid coil H₅, one end of which is connected to the common transmitting and receiving circuit TR² and the other end of which is connected to a balancing network N². The receiving channel 20 includes the demodulator 22 the output circuit of which is coupled to the attendant's receiver R. The transmitting channel 21 includes the balanced modulator 23 the output circuit of which is coupled through the low-frequency circuit 24 to the attendant's transmitter T. The hybrid coil H₅ prevents excessive side tone in the attendant's receiver. The modulator 23 is of the balanced type disclosed in the Carson patent, supra, designed to prevent the passage of the carrier current to the line.

The demodulator 22 and the modulator 23 are rendered conjugate by means of a hybrid coil H₆, thus preventing singing at the repeater. The double frequency oscillator 25 is coupled to the hybrid coil H₆, by means of the transformer 26, the balancing network N₆ being connected to the other side of the hybrid coil.

The double frequency oscillator 25 may be adjusted by means of variable condensers 27 and 28 to generate simultaneously the two carrier waves of any desired frequency which are required for east and west transmissions.

In describing the operation of the system of Fig. 3, it may be assumed that the repeater attendant desires to monitor and talk on channel No. 2, similar to the transmitting and receiving channel associated with the low frequency line L₂ of Fig. 1. In this case the attendant inserts plugs 10 and 14 into jacks J₁ and J₄, respectively, and inserts plugs 12 and 16 into jacks J₂ and J₆, respectively. The sideband transmitted from the west station passes through the repeater directional filter HPIF amplifier A₁ and filter HPOF to the line ML, and thence to the east station. A portion of such sideband in the output of amplifier A₁ passes through jack J₄, plug 14, resistances R, band filter MBF₂, plug 10, jack J₁, circuit TR₂, through the hybrid coil H₅, receiving channel 20 to the demodulator 22. There is likewise fed into the demodulator 22 a carrier current of a frequency equal to that suppressed at the transmitting terminal, from the double frequency oscillator 25 the variable condenser 27 of which may be assumed to be adjusted to cause the generation of that particular fre-

quency. The voice currents transmitted from the west station appear in the receiver R as one of the components of demodulation. Similarly, a portion of the incoming sideband from the east station passes from the output side of repeater A₂ through band filter MBF₂ to the demodulator 22 where it is combined with a carrier current of a frequency equal to that suppressed at the transmitting terminal, which carrier is supplied by the double frequency oscillator 25 the variable condenser 28 of which is adjusted to cause the generation of that particular frequency.

When the repeater attendant desires to talk to another station, the voice frequency currents from the transmitter T are impressed upon the input circuit of the balanced modulator 23 and are caused to modulate the carrier currents which are fed to the modulator from the double frequency oscillator 25. The carrier currents are balanced out in the modulator 23 and the side bands are transmitted through the hybrid coil H₅ and the band filters MBF₂ and M₁BF₂ and out on the carrier line. Hence, when the repeater attendant talks the sideband currents are transmitted to both the east line and the west line and the attendant is able to talk to other repeaters or to either terminal station.

When it is desired to monitor and talk on any other channel on the system, the appropriate monitoring band filters are associated with the channel taps in the output circuits of amplifiers A₁ and A₂ and the condensers 27 and 28 are so adjusted that the double frequency oscillator 25 will generate simultaneously the two carriers appropriate to the east and west transmissions of the selected channel.

The invention set forth herein is, of course, susceptible of various modifications and adaptations, and accordingly the invention is not to be considered as limited except as defined by the scope of the appended claims.

What is claimed is:

1. In a carrier wave signaling system, a multiplex carrier line employing carrier waves of different frequencies for carrying messages, a repeater associated with said line and including a wave filter having a plurality of sections and an amplifier dividing said sections into two groups, a monitoring circuit, a plurality of selective paths associated with said repeater between the output of said amplifier and one of said filter groups, each of said paths being selective to a different one of said carrier waves, and means for selectively associating said monitoring circuit with a desired one of said selective paths.

2. In a carrier wave signaling system, a multiplex carrier line employing carrier

waves of different frequencies, a repeater associated with said line, means at said repeater for selecting a wave from said line, means for observing the selected wave, and means for retransmitting said wave through said selecting means.

3. In a carrier wave signaling system, a multiplex carrier line employing carrier waves of different frequencies, a repeater associated with said line, channel taps at said repeater, means adapted to be associated with said channel taps for selecting a wave from one of the carrier channels, means for detecting the selected wave and means for retransmitting said wave through said selecting means.

4. In a carrier wave signaling system, a multiplex carrier line employing carrier waves of different frequencies, a repeater associated with said line, a channel tap at said repeater, a band filter associated with said channel tap for selecting a wave from said line, means for detecting a wave selected by said band filter, and means for retransmitting said wave through said band filter.

5. In a carrier wave signaling system, a multiplex carrier line employing carrier waves of different frequencies, a repeater including an amplifier associated with said line, a channel tap in the output of said amplifier, a band filter associated with said channel tap for selecting a wave from said line, means for detecting a wave selected by said band filter, and means for retransmitting said wave through said band filter.

6. In a carrier wave signaling system, a multiplex carrier line employing carrier waves of different frequencies, a repeater associated with said line, a channel tap at said repeater, a band filter associated with said channel tap for selecting a wave from said line, a detector for the wave selected by said band filter for deriving the signal component and the high frequency wave component, and means for retransmitting the high frequency wave component controlled by other signals through said band filter.

7. In a carrier wave signaling system, a multiplex carrier line employing carrier waves of different frequencies, a repeater associated with said line and including a wave filter having a plurality of sections and an amplifier dividing said sections into two groups, a channel tap in the output of said repeater amplifier, a band filter associated with said channel tap for selecting a wave from said line, a detector for the wave selected by said band filter for deriving the signal component and the high frequency wave component, and means for retransmitting the high frequency wave component controlled by other signals through said band filter.

8. In a carrier wave signaling system, a multiplex carrier line employing carrier waves of different frequencies for oppositely directed transmissions, a repeater associated with said line, channel taps at said repeater, a loop monitoring circuit having a common input and output circuit, band filters associated with said channel taps, switching means for connecting said common input and output circuit to each of two band filters associated with oppositely directed channels, and means in said loop monitoring circuit for detecting a wave transmitted through one of said band filters and for retransmitting said wave through the same band filter.

9. In a carrier wave signaling system, a multiplex carrier line employing carrier waves of different frequencies for oppositely directed transmissions, a repeater associated with said line, channel taps at said repeater, a loop monitoring circuit having a common input and output circuit, band filters associated with said channel taps, switching means for connecting said common input and output circuit to each of two band filters associated with oppositely directed channels, a demodulator in said loop monitoring circuit for deriving the signal component and the high frequency component of a wave transmitted through one of said band filters, a telephone receiver in the output of said demodulator for observing the detected signal, and means for retransmitting the high frequency wave component controlled by other signals through said last mentioned band filter.

10. In a carrier wave signaling system, a multiplex carrier line employing carrier waves of different frequencies for oppositely directed transmission, a repeater including amplifiers for amplifying the oppositely directed carrier waves, channel taps in the output circuits of said amplifiers, a loop monitoring circuit having a common input and output circuit, band filters associated with said channel taps, switching means for connecting said common input and output circuit to each of two band filters associated with oppositely directed channels, means in said loop monitoring circuit for detecting a wave transmitted through one of said band filters, and means for retransmitting said wave through the same filter.

11. In a carrier wave signaling system, a multiplex carrier line employing carrier waves of different frequencies for oppositely directed transmission, a repeater associated with said line and including a channel for repeating in one direction currents of one range of frequencies and a channel for repeating in the other direction a band of currents outside of said range of frequencies, each channel comprising a band filter consisting of two groups of recurring sections

- and an amplifier electrically interposed between said groups, channel taps in the output circuits of said amplifiers, a loop monitoring circuit having a common input and output circuit, band filters associated with said channel taps, switching means for connecting said common input and output circuit to each of two band filters associated with oppositely directed channels, and means in said loop monitoring circuit for detecting a wave transmitted through one of said band filters and for retransmitting said wave through the same filter.
12. In a carrier wave telephone system, a multiplex carrier line employing carrier waves of different frequencies for transmitting messages in opposite directions, a two-way repeater comprising band filters, each of which consists of two groups of recurring sections for separating the oppositely directed messages and amplifiers, respectively, positioned between the groups of filter sections, a monitoring circuit, selective filters, and means for connecting said monitoring circuit through the selective filters to the output circuits of said amplifiers whereby monitoring may be effected on the messages transmitted in either direction and whereby conversation may be effected from the repeater with another station.
- In witness whereof, I hereunto subscribe my name this 12th day of June A. D., 1924.

JACOB S. JAMMER.