

1 597 174

- (21) Application No. 51253/77 (22) Filed 9 Dec. 1977 (19)
- (31) Convention Application No. 2 655 790 (32) Filed 9 Dec. 1976 in
- (33) Fed. Rep. of Germany (DE)
- (44) Complete Specification published 3 Sept. 1981
- (51) INT. CL.<sup>3</sup> A24C 5/32
- (52) Index at acceptance  
A2C 1C3



(54) APPARATUS FOR THE AXIAL SEPARATION OF ROD-LIKE ARTICLES OF THE TOBACCO-PROCESSING INDUSTRY

(71) We, HAUNI-WERKE KÖRBER & CO KG., a German Company of Kampchausee 12—22, 2050 Hamburg 80, Germany (Fed. Rep.) do hereby declare the invention, for which we pray that a patent may be granted to us, and the method by which it is to be performed, to be particularly described in and by the following statement:—

The invention relates to an apparatus for the axial separation of pairs of rod-like articles of the tobacco-processing industry aligned coaxially, for the purpose of providing a gap between the articles for the insertion of a further rod-like article, comprising a conveyor for transporting the articles in succession at right-angles to their longitudinal axes.

Within the scope of the invention, the term “rod-like articles of the tobacco-processing industry” is intended to mean smokable articles made from tobacco and tobacco substitutes as well as filter sections, in particular the combination of these two components for producing filter cigarettes.

According to a known method of production, tobacco rods of double length are cut into two parts on a cutting drum and these parts are transferred in pairs bearing against each other at their head ends, to a further conveyor, on which they are separated from each other axially to such an extent that a double length filter rod can be inserted in the gap.

An apparatus of the afore-described type is known from U.S. Patent Specification 3,372,702 for example, the conveyor for the axial separation of the cigarette rods consisting of four conical drums.

An object of the invention is to provide an apparatus for the aforesaid type, of particularly compact construction, which can be adapted quickly and with little expenditure to changes in the format of the rod-like articles.

According to the present invention there is provided apparatus for the axial separation of pairs of rod-like articles of the tobacco-processing industry aligned coaxially, for the purpose of providing a gap between the articles for the insertion of a further rod-like

article, comprising a conveyor for transporting the articles in succession at right-angles to their longitudinal axes, having on its periphery two rows of holders for the articles, the plurality of holders of at least one row for carrying one article of each pair being combined as segment blocks arranged to move relative to the holders of the other row for carrying the other article of each pair.

The conveyor is appropriately constructed as a drum. In order to keep the acceleration of the articles as low as possible at the time of separation, it is also proposed according to the invention that a plurality of holders form segment blocks of the conveyor able to move in pairs and in opposite directions relative to each other, whereby careful handling of the cigarettes is ensured.

According to an additional feature, a displacement of the segment blocks which is particularly easy to achieve as regards the drive is possible due to the fact that associated with at least one segment block are actuating means driven by a control cam whereby according to a further proposal, one pair of segment blocks is respectively provided with two actuating means, with which one control cam is respectively associated for driving the actuating means in opposite directions.

The actuating means are appropriately constructed as push or pull rods.

A particularly simple arrangement of the segment blocks is provided according to one advantageous embodiment due to the fact that they are arranged to move on a casing rotating about a stationary drum body. In order to be able to retain the segment blocks reliably on the drum body, during rotation of the conveyor, it is also proposed that each pair of segment blocks is provided with two guide rods.

In order to be able to move the actuating rods on the one hand and the guide rods on the other hand in a defined manner, the invention also provides that the casing is provided with radial retaining flanges for the actuating rods and that in addition one of the

50  
55  
60  
65  
70  
75  
80  
85  
90  
95

retaining flanges comprises pairs of rollers for guiding the guide rods.

For the drive of the actuating rods, it is also provided that they are connected to angle supports whose free end supports a control roller, which rolls in a stationary control cam.

The control cam is thus appropriately constructed as a cup-shaped cam extending over the periphery of a cylindrical body.

One embodiment according to the invention also provides that associated with the conveyor are a supply conveyor and discharge conveyor, in whose region of cooperation with the conveyor, the control cam extends exclusively in the peripheral direction of the cylindrical body. It is thus ensured that when articles are received and discharged, the segment blocks remain stationary in the axial direction, so that a reliable transfer of articles is possible.

The invention will be described in detail hereafter with reference to one embodiment illustrated in the drawings:

Figure 1 is a longitudinal section through a conveyor according to the invention,

Figure 2 is an underneath view of the segment blocks in the direction of arrow II and

Figure 3 is a partial cross-section through the conveyor on line III—III of figure 1 with supply and discharge conveyors illustrated diagrammatically and associated directly with the conveyor.

The conveyor according to figure 1 consists of a drum 1, which is mounted on a housing wall 2 of the machine. For this purpose, an inner drum body 3 constructed as a hollow cylinder is fixed to the housing wall 2. A further hollow cylindrical drum body 4 is likewise fixed to the housing wall 2 and surrounds the drum body 3 in an annular manner and at a distance. The space between the two drum bodies 3 and 4 forms a vacuum channel 6, which is connected to a vacuum source (not shown) by way of a vacuum connection 7 located on the drum body 4. The drum body 4 is also provided with annular vacuum slots 8, 9 extending at right-angles to its axis. In addition, the outer drum body 4 is provided with a compressed air channel 11, which is connected by way of a pressure connection 12 to a source of compressed air which is not shown and at the outlet side is connected to compressed air bores 13, 14.

A cylindrical casing 16 is mounted to rotate on the outer stationary drum body 4. Serving to initiate the rotary movement of the casing 16 is a shaft 17, which is mounted in the inner drum body 3 by means of ball bearings 18 and 19 and which comprises a flange 21, which is screwed to the casing 16. The casing 16 comprises control slots 22 and 23. The casing 16 of the drum 1 is also provided on its periphery with a plurality of holder grooves 24, a plurality of holder grooves, in the present case

five holder grooves being combined respectively to form a segment block on the left-hand side and a segment block on the right-hand side, which are located opposite each other in pairs in the direction of their longitudinal axes. In the embodiment four segment blocks on the left-hand side and four segment blocks on the right-hand side are respectively located on the periphery of the drum 1. The segment blocks 26 and 27 are provided with air bores 28, which connect the holder grooves 24 selectively by way of the slots 8, 9, 22 and 23 to the vacuum channel 6 or by way of the compressed air bores 13 and 14 to the compressed air channel 11.

The segment blocks 26 and 27 rotating with the casing 16 are also able to move in the direction of their longitudinal axes on the casing 16, for which purpose actuating means in the form of rods 29, 31 are provided. The actuating rods 29 and 41 are mounted to move axially in radial retaining flanges 32 and 33 of the casing 16, for the purpose of guidance. In order that they are guided with little friction, ball bearing cages 34 are provided for this purpose, one of which is shown in section in figure 1. Two guide rods 36 and 37 are also provided for each pair of segment block 26 and 27, which rods are likewise guided through the retaining flange 33 of the casing 16. The guide rods 36 and 37 are also guided at the upper and lower sides by two pairs of rollers 38 and 39, which are mounted on a roller block 41 attached to the retaining flange 33.

By means of the rods 29 and 31 and the guide rods 36 and 37, the segment blocks 26 and 27 are able to move on the casing 16 in the axial direction of the drum 1, for which reason, according to figure 2, one rod 29 for one half of a pair of segment blocks 26 and 27 and the other rod 31 for the other half of the respective pair of segment blocks is fixed to the latter. Thus, the rods 29 and 31 as well as the guide rods 36 and 37 are alternately fixed to the halves of a pair of segment blocks 26 and 27 or guided therethrough with clearance. For actuation, the rods 29 and 31 are fixed to angle supports 42, whose free end supports a control roller 43. A control cam 46, 47, extending over the periphery of a hollow cylinder 44, which cams are constructed as cup-shaped cams, is respectively associated with one half of the pairs of segment blocks 26, 27. The control rollers 43 associated with the actuating rods 29 for the segment blocks 27 and the control rollers 43 associated with the actuating rods 31 for the segment blocks 26 roll in these oppositely directed control cams 46 and 47, during the rotation of the casing 16. The hollow cylinder 44 is locked by means of a housing cover 48 on the end face, which cover is in turn fixed to the housing wall 2 by means of a rod 49 by way of an angle support 51. The drive shaft 17 is sup-

ported inside the hollow body 44 by means of ball bearings 52 and 53.

According to figure 3, the conveyors located directly before or after the drum 1 consist of a transfer drum 54, which transfers double length cigarette rods to an aligning and cutting drum 56. On the cutting drum 56, the cigarette rods are aligned to form a row of cigarette rods located one behind the other and are cut centrally by a circular cutter 57. The cigarette rods Z cut in this way and having their end faces in abutment are then transferred to the holder grooves 24 of the segment blocks 26, 27 of the drum 1. In the transfer region designated by the reference A, the control cams extend exclusively in the peripheral direction of the hollow cylinder 44, in order to ensure reliable transfer. During further rotation of the drum 1, i.e. when the cigarettes Z are moved away from the transfer point A, the control rollers 43 pass into the part of the control cams 46, 47 extending at right-angles to the axis of the hollow cylinder 44. In this case, in the opposite direction, the actuating rods 29 with the segment blocks 27 are moved towards the right and the actuating rods 31 with the segment blocks 26 are moved towards the left, so that the head ends of the cigarettes Z, abutting against each other, are separated axially. During this operation, the cigarettes Z are held under the influence of a vacuum by way of the air bores 28, the vacuum slots 8 and 9, the control slots 23 and 24, the vacuum channel 6 and the vacuum connections 7 and are therefore held reliably in the holder grooves 24. In this way, the pairs of segment blocks 26, 27 with the separated cigarettes Z arrive in the discharge region designated by the reference B, opposite an assembly drum 58. In this discharge region B, the control rollers 43 of the actuating rods 29 moved towards the right as well as of the actuating rods 31 moved towards the left are once more guided in parts of the control cams 46, 47 extending exclusively in the peripheral direction of the hollow cylinder 44, in order to ensure a reliable discharge of the cigarettes to the assembly drum 58. After the discharge of the cigarettes Z, the air bores 28 of the segment blocks 26 and 27 are cleared of possible dirt by means of the compressed air prevailing at the pressure connection 12, by way of the compressed air channel 11 and the compressed air bores 13, 14. On the assembly drum 58, double length filter rods are inserted in the gaps produced between the cigarette rods Z, which filter rods are transferred by a drum 59 to the assembly 58.

The advantage achieved by the invention consists in that the pairs of cigarettes can be separated in a careful manner on a single drum, in which case for changes of the format, it is solely necessary to mount a new hollow cylinder with corresponding control

cams, which is quite possible from the end face of the drum.

#### WHAT WE CLAIM IS:—

1. Apparatus for the axial separation of pairs of rod-like articles of the tobacco-processing industry aligned coaxially, for the purpose of providing a gap between the articles for the insertion of a further rod-like article, comprising a conveyor for transporting the articles in succession at right-angles to their longitudinal axes, having on its periphery two rows of holders for the articles, the plurality of holders of at least one row for carrying one article of each pair being combined as segment blocks arranged to move relative to the holders of the other row for carrying the other article of each pair.

2. Apparatus according to claim 1, wherein the conveyor is constructed as a drum.

3. Apparatus according to claims 1 or 2, wherein the holders of each row form segment blocks and the segment blocks of the two rows are able to move in pairs of opposite directions relative to each other.

4. Apparatus according to any one of claims 1 to 3, wherein actuating means driven by a control cam are associated with at least one segment block.

5. Apparatus according to claims 3 and 4, wherein each pair of segment blocks is provided with two actuating means, with which a control cam is associated for driving the actuating means in opposite directions.

6. Apparatus according to claim 4 or 5, wherein the actuating means are constructed as push or pull rods.

7. Apparatus according to one or more of claims 1 to 6, wherein the segment blocks are located to move on a casing rotating about a stationary drum body.

8. Apparatus according to claim 3 or any one of claims 4 to 7 when directly or indirectly dependent on claim 3, wherein each pair of segment blocks is provided with two guide rods.

9. Apparatus according to claim 7 or claims 7 and 8, wherein the casing is provided with radial retaining flanges for the actuating rods.

10. Apparatus according to claims 8 and 9, wherein one of the retaining flanges comprises pairs of rollers for guiding the guide rods.

11. Apparatus according to claim 6 or any one of claims 7 to 10 when directly or indirectly dependent on claim 6, wherein the actuating rods are fixed to angle supports, whose free end supports a control roller, which rolls in a stationary control cam.

12. Apparatus according to claim 11, wherein the control cam is constructed as a cup-shaped cam extending over the periphery of a cylindrical member.

13. Apparatus according to claim 11 or 12, wherein associated with the conveyor are a supply conveyor and discharge conveyor, in whose respective region of cooperation with the conveyor, the control cam extends exclusively in the peripheral direction of the cylindrical member.
- 5 14. Apparatus for the axial separation of pairs of rod-like articles of the tobacco-processing industry, substantially as herein described with reference to and as illustrated in the accompanying drawings. 10

WHEATLEY & MACKENZIE,  
Scottish Life House,  
Bridge Street,  
Manchester M3 3DP.

Printed for Her Majesty's Stationery Office by Burgess & Son (Abingdon), Ltd.—1981.  
Published at The Patent Office, 25 Southampton Buildings, London, WC2A 1AY,  
from which copies may be obtained.

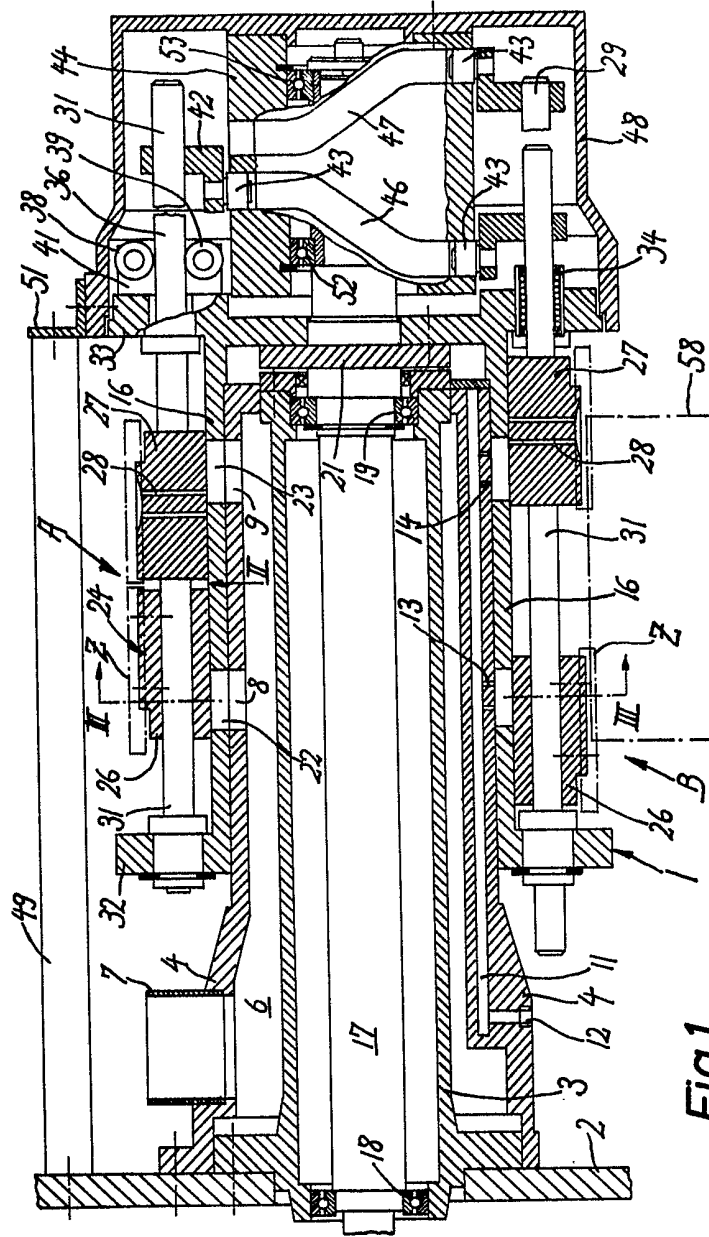

Fig.1



