



(86) Date de dépôt PCT/PCT Filing Date: 2006/11/27  
 (87) Date publication PCT/PCT Publication Date: 2007/06/21  
 (45) Date de délivrance/Issue Date: 2012/04/24  
 (85) Entrée phase nationale/National Entry: 2008/06/12  
 (86) N° demande PCT/PCT Application No.: ES 2006/000657  
 (87) N° publication PCT/PCT Publication No.: 2007/068771  
 (30) Priorité/Priority: 2005/12/14 (ES P 200503076)

(51) Cl.Int./Int.Cl. *B65H 18/10* (2006.01)  
 (72) Inventeurs/Inventors:  
 PRAT GIL, JORDI, ES;  
 COMBIS PALACIOS, AGUSTI, ES  
 (73) Propriétaire/Owner:  
 PROSLIT EQUIPMENT, S.L., ES  
 (74) Agent: FETHERSTONHAUGH & CO.

(54) Titre : DISPOSITIF DE ROULEAU DE PRESSE DESTINE A UNE MACHINE DE COUPE DE MATERIAU LAMINAIRE ENROULE

(54) Title: PRESSURE ROLLER DEVICE FOR A WOUND WEB MATERIAL CUTTING MACHINE

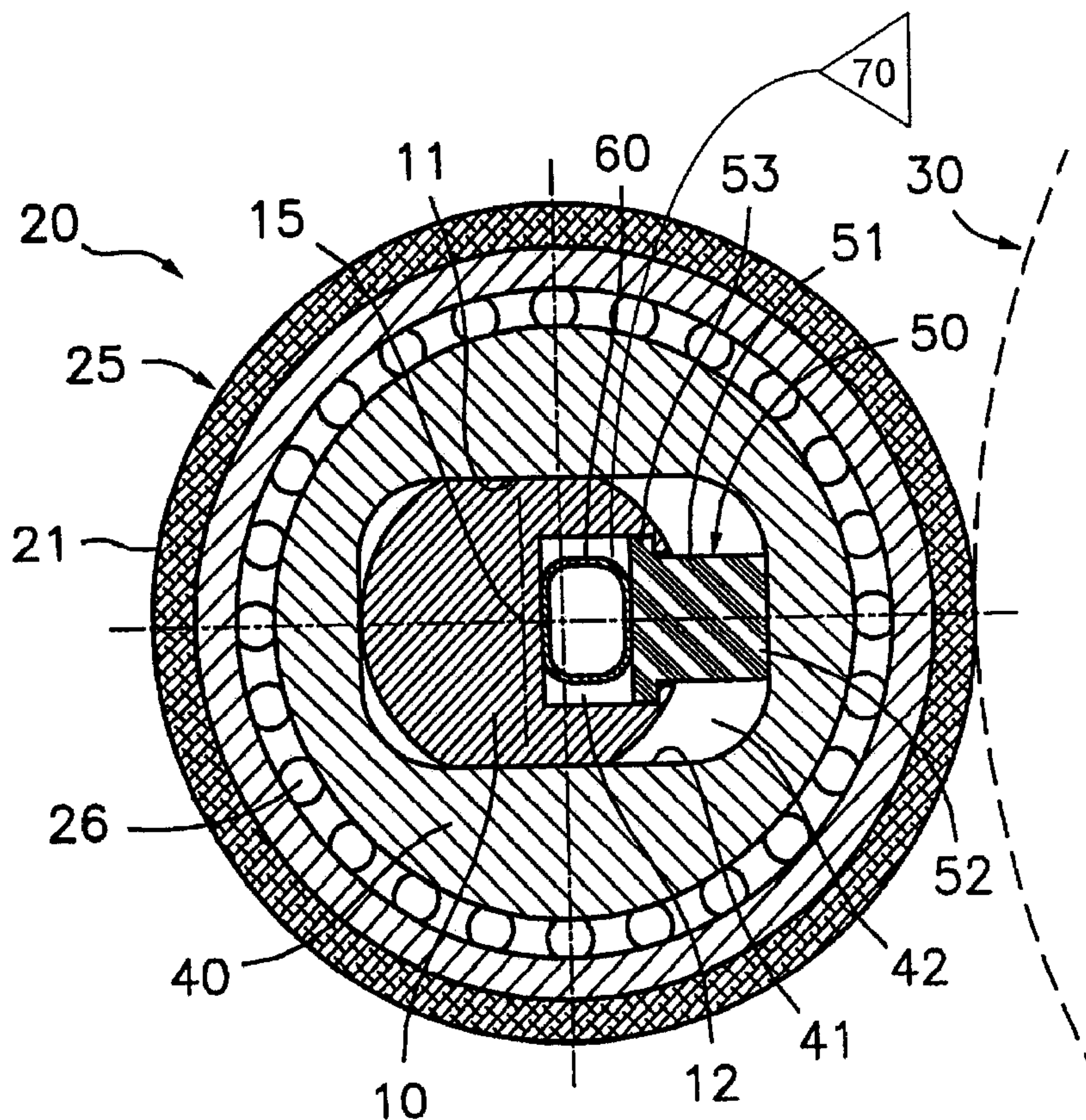

(57) Abrégé/Abstract:

The invention relates to a pressure roller device for a wound web material cutting machine comprising a support bar (10) on which a pressure roller (20) is rotatably mounted, said pressure roller being formed by a plurality of adjacent pressure segments (25)

(57) **Abrégé(suite)/Abstract(continued):**

which each have an outer cylindrical surface (21) opposite a reel (30). The invention includes guide means for guiding the movements of the pressure segments (25) in a radial direction in relation to the support bar (10) and thrust means for individually and independently thrusting each pressure segment (25) guided in the guide means against the reel (30). The outer cylindrical surfaces (21) of the pressure segments (25) can therefore be positioned off-centre in relation to a central line (15) of the support bar (10) with different eccentricities individually determined by the contact between the outer cylindrical surface (21) of each pressure segment (25) and the reel (30).

**ABSTRACT**

The invention relates to a pressure roller device for a wound web material cutting machine comprising a support bar (10) on which a pressure roller (20) is rotatably mounted, said  
5 pressure roller being formed by a plurality of adjacent pressure segments (25) which each have an outer cylindrical surface (21) opposite a reel (30). The invention includes guide means for guiding the movements of the pressure segments (25) in a radial direction in relation to the support bar (10) and thrust means for individually and independently thrusting each pressure segment (25) guided in the guide means against the reel (30). The outer cylindrical surfaces (21)  
10 of the pressure segments (25) can therefore be positioned off-centre in relation to a central line (15) of the support bar (10) with different eccentricities individually determined by the contact between the outer cylindrical surface (21) of each pressure segment (25) and the reel (30).

- 1 -

**PRESSURE ROLLER DEVICE FOR A WOUND WEB MATERIAL CUTTING  
MACHINE**

**Field of the Art**

5           The present invention relates to a pressure roller device applied to a wound web material cutting machine, useful in the graphic arts industry to compensate for fluctuations in the thickness of the web material that is being cut and wound and to prevent the lateral sliding of web materials with a low coefficient of friction.

10       **State of the Prior Art**

          Cutting-winding machines are known which have means for making one or more longitudinal cuts in a flexible web material unwound from a single reel, and means for re-coiling the two or more resulting strips into corresponding coaxially arranged narrower take-up reels. In these types of machines, it is known to arrange a single pressure roller associated to a thruster to  
15       apply pressure on the several take-up reels as the cut material is wound. However, this single roller is not able to adapt to small differences in diameter of the take-up reels due to variations in the thickness of the cut material, so that it cannot assure that the pressure actually applied to each reel is the same.

          It is also known to arrange several independent pressure roller and thrust device  
20       assemblies to be able to independently apply substantially equal pressures to each of the several take-up reels. In this case, each assembly comprises a pivoting arm supporting the shaft of the pressure roller and a pneumatic cylinder arranged between a base plate and the pivoting arm for thrusting the roller towards the corresponding take-up reel. However, the mechanical assembly of the different pressure rollers requires leaving separation gaps between them which limit the  
25       minimum width of the take-up reels and make it difficult to adapt the system of pressure rollers to reels having different widths. In addition, this arrangement results in a relatively complex construction, with high manufacturing and maintenance costs.

**Disclosure of the Invention**

30           The present invention contributes to overcoming the aforementioned and other drawbacks by providing a pressure roller device for a wound web material cutting machine comprising in combination: a support bar (10) on which a pressure roller (20) is rotatably mounted, said support bar (10) having two parallel planar outer faces (11) and a housing (12) formed therealong, said housing (12) having a longitudinal opening located between said two  
35       planar outer faces (11); said pressure roller being formed by a plurality of adjacent pressure segments (25), each of said pressure segments (25) comprises a core (40) with a cavity (42)

- 2 -

having two parallel planar inner faces (41) in sliding contact with said planar outer faces (11) of the support bar (10), and an outer cylindrical surface (21) rotatably mounted on said core (40) and opposite an outer cylindrical surface of at least one reel (30), said planar faces (11, 41) forming guide means for guiding movements of the pressure segments (25) in a radial direction  
5 in relation to said support bar (10); a plurality of thrust members (50), each associated to one core (40) and each having a guide portion (51) inserted in said housing (12) of the support bar (10) such that it can slide outwardly and inwardly thereof in a direction parallel to the two planar outer faces (11) of the support bar (10), and a projecting portion (52) arranged for applying pressure against an inner surface of said cavity (42) of the core (40) of the pressure segment (25)  
10 when said thrust member (50) is moved outwardly from the housing (12); and thrust means in the form of a an expandable sleeve (60) arranged in said housing (12) along the support bar (10) between a bottom surface of the housing (12) and an end surface of each of said guide portions (51) of the thrust members (50), said expandable sleeve (60) being able to be expanded by a pressurized fluid for individually thrusting the pressure segments (25) against the at least one reel  
15 (30) with a common pressure; characterized in that: the thrust member (50) has protuberances (53) formed next to an inner end of the guide portion (51), and said longitudinal opening of the housing (12) of the support bar (10) has flanges interfering with said protuberances (53), so that the thrust member (50) is retained in the housing (12) with limited sliding possibility; and the longitudinal opening of the housing (12) has a widening (13) located in at least one end of the  
20 support bar (10) projecting from the pressure roller (20), said widening (13) having a sufficient size to allow the passage of the guide portions (51) and protuberances (53) of the thrust members (50).

With this construction, the device of the present invention ensures that the same pressure will be applied in each reel, which provides a uniform hardness or compacting degree in all the  
25 reels.

The pressure roller device of the present invention has the advantages in terms of performances of a known type construction having separate individual rollers, and however, as a result of being mounted on a common support bar, it can be supported on a support structure that is as simple as the one used for a prior art single pressure roller.

30 Furthermore, the device of the present invention allows increasing the production time of the cutting machine, since it does not have to change the rollers to go, for example, from a single pressure roller to individual pressure rollers, nor does it have to make axial movements of the different pressure rollers in order to adjust the cutting machine to different reel widths.

The pressure roller device of the present invention, including individual pressure  
35 sections, allows a smaller minimum reel width than the previously known devices.

- 2a -

**Brief Description of the Drawings**

The previous and other advantages and features will be more fully understood from the following detailed description of an embodiment with reference to the attached drawings, in  
5 which:

Figure 1 is an isometric view of one end of a pressure roller device for a wound web material cutting machine according to an embodiment of the present invention;

Figure 2 is a cross-section view of the roller device of Figure 1 with a contracted expandable element and a pressure segment in a retracted position in relation to a support bar;

10 Figure 3 is a cross-section view similar to Figure 2, but with the expandable element being expanded and the pressure segment in an extended position in relation to the support bar;  
and

Figure 4 is a longitudinal section view of the pressure roller device of Figure 1.

15 **Detailed Description of an Exemplary Embodiment**

Referring first with to Figure 1, the pressure roller device for a wound web material cutting machine comprises, according to one exemplary embodiment, a support bar 10 on which a pressure roller 20 is rotatably mounted, said pressure roller being formed by a plurality of adjacent pressure segments 25 very close to one another. Each of said pressure segments 25 has an outer cylindrical surface 21 opposite an outer cylindrical surface of at least one reel 30 (indicated by means of dotted lines in Figures 2 and 3). In general, the cutting machine incorporates several take-up reels 30 for taking up and winding respective strips of material cut from a wider strip coming from a single input reel (not shown). The various take-up reels 30 are coaxial in relation to a shaft parallel to a central line 15 of the support bar 10, and each pressure segment 25 can correspond to one of the take-up reels 30, or there can be several pressure segments 25 for each of the several take-up reels 30. The cutting machine has means for moving the support bar 10 towards the take-up reels 30 to put the pressure segments 25 into contact with the same.

The device of the present invention further comprises guide means adapted for guiding movements of the pressure segments 25 in a radial direction in relation to said support bar 10, and thrust means adapted for individually and independently thrusting each pressure segment 25 guided in said guide means against said at least one reel 30. Therefore, the outer cylindrical surfaces 21 of the pressure segments 25 can be positioned off-centre in relation to a central line 15 of the support bar 10 to compensate for differences in diameter of the several take-up reels 30 caused by possible fluctuations in the thickness of the web material that is being cut and wound. The pressure exerted by the pressure segments 25 on the take-up reels 30 further serves to provide a certain hardness or compacting degree to the reels and to prevent the lateral sliding of web materials with a low coefficient of friction. The degree of eccentricity of each of the pressure segments 25 is individually determined by the contact of the outer cylindrical surface 21 of each pressure segment 25 with an outer cylindrical surface of the reel 30. However, since said thrust means comprise an expandable element 60 driven by a pressurized fluid common for all the pressure segments 25, the pressure segments 25 are individually thrust against the take-up reels 30 with a single pressure common to all of them.

As better shown in Figures 2 and 3, the support bar 10 is generally cylindrical and has formed two diametrically opposite planar outer faces 11 parallel to one another and parallel to the central line 15 of the support bar 10. These two planar outer faces 11 are in sliding contact with corresponding parallel planar inner faces 41 formed in a cavity 42 of a core 40 on which the pressure segment 25 rotates, such that said core 40 together with the pressure segment 25 can be radially moved in relation to the support bar 10. The planar outer faces 11 of the support bar together with the mentioned planar inner faces 41 of said core 40 form the guide means referred to above. The mentioned thrust means comprise, in addition to said expandable element 60, at

- 4 -

least one thrust member 50 for each pressure segment 25. This thrust member 50 is located between the support bar 10 and the core 40 of the corresponding pressure segment 25, and the expandable element 60 is located along the support bar 10 between the support bar 10 and all the thrust members 50. The mentioned pressurized fluid is preferably pressurized air, although it  
5 could be any other gas or even a liquid.

In the situation shown in Figure 2, the expandable element 60 is substantially empty of fluid and adopts a contracted shape, so that the thrust member 50 is retracted and the pressure segment 25 can adopt an also retracted position in relation to the support bar 10.

In the situation shown in Figure 3, the expandable element 60 is full of fluid at a certain  
10 pressure, so that it is expanded up to a certain extent. The expansion of the expandable element 60 individually thrusts all the thrust members 50 against the respective cores 40 and the latter move radially together with the respective pressure segments 25 to an extended position in relation to the support bar 10, in which the outer cylindrical surfaces of the pressure segments 25 are in contact with the corresponding take-up reels 30. During the operation, the expansion of the  
15 expandable element 60 allows the degree of extension of each of the different pressure segments 25 to adjust to the particular diameter of the corresponding take-up reel 30 and, however, the pressure exerted by the expandable element 60 is common and uniform for all the pressure segments 25.

It must be indicated that although Figures 2 and 3 show the limit retracted and extended  
20 positions, respectively, during an actual operation the pressure segments 25 will fluctuate between intermediate retracted and extended positions without reaching, except in exceptional situations, the mentioned limit retracted and extended positions.

The support bar 10 has formed therealong a housing 12 in the forma of a groove with a longitudinal opening located between said two planar outer faces 11 of the support bar 10. Each  
25 of the thrust members 50 comprises a guide portion 51 inserted in said housing 12 of the support bar 10 such that it can slide out of and into such housing in a direction parallel to the two planar outer faces 11 of the support bar 10. The thrust member 50 also comprises a projecting portion 52 having an end adapted for applying pressure on an inner surface of the mentioned cavity 42 of the core 40 of the pressure segment 25 when the thrust member 50 is moved out of the housing 12.  
30 The expandable element 60 has the form of an expandable sleeve 60 arranged along the housing 12 from one end of the support bar 10 to the other, and placed between a bottom surface of the housing 12 and an end surface of each of said guide portions 51 of the thrust members 50. The expandable sleeve 60 can be connected to a pressurized fluid source 70 through valve means associated to the support bar 10, and said valve means can be closed to retain an amount of fluid  
35 at a predetermined pressure inside the expandable sleeve 60.

At opposite edges of the longitudinal opening of the housing 12 of the support bar 10 there are formed flanges aimed towards one another which interfere with protuberances 53 formed next to an inner end of the guide portion 51 of each thrust member 50. As a result, the thrust members 50 are retained in the housing 12 with limited sliding possibility due to the interference of the flanges of the housing 12 with the protuberances 53 of the thrust members 50. The support bar 10 has ends projecting from the pressure roller 20, and, in at least one of these projecting ends of the support bar 10 (shown in Figure 1), the longitudinal opening of the housing 12 has a widening 13 with a sufficient size to allow the passage of the protuberances 53 of the guide portions 51 of the thrust members 50. Thus, for the assembly of the pressure roller device of the present invention, the thrust members 50 can be introduced one after another through the mentioned widening 13 and then slid along the housing 12 until their operational position. A stop 14 is fixed inside a portion of the housing 12 located at the projecting end of the support bar 10 and facing said widening 13. The purpose of said stop 14 is to retain the thrust members 50 inside the housing 12 of the support bar 10 once they have been introduced, preventing a movement thereof in the direction of the central line 15.

With reference now to Figure 4, each pressure segment 25 comprises a cover 21a of a suitable material to provide the outer cylindrical surface 21, fixed on a structural bush 29, which is rotatably mounted on its corresponding core 40 by means of a pair of bearings 26, which are of a type adapted to furthermore retain the pressure segment 25 on its corresponding core 40 against a movement in an axial direction. Between every two adjacent pressure segments 25 there are arranged one or more separators 27 in the form of blocks of a material with a low coefficient of friction fixed to the core 40 of one of the two adjacent pressure segments 25 by means of screws 42. Each of these separators 27 is in sliding contact with a side surface of the core 40 of the other one of the two adjacent pressure segments 25 to allow movements of the pressure segments 25 in the radial direction along the guide means described above while at the same time they assure a minimal separation allowance between the adjacent pressure segments 25. Next to each of the two pressure segments 25 located at the ends of the pressure roller 20 (only one of which is shown in Figure 4) there are arranged one or more stops 28 fixed to one of the planar outer faces 11 of the support bar 10 by means of screws 16. These stops 28 are in sliding contact with a side surface of the core 40 of the corresponding end pressure segment 25 and retain the assembly of pressure segments 25 forming the pressure roller 20 against movements in the axial direction while at the same time they allow movements of the end pressure segments 25 in the radial direction.

A person skilled in the art will be able to introduce variations and modifications in the embodiment shown and described without departing from the scope of the present invention as it is defined in the attached claims.

**CLAIMS**

1.- A pressure roller device for a wound web material cutting machine comprising in combination:

5 a support bar (10) on which a pressure roller (20) is rotatably mounted, said support bar (10) having two parallel planar outer faces (11) and a housing (12) formed therealong, said housing (12) having a longitudinal opening located between said two planar outer faces (11);

said pressure roller being formed by a plurality of adjacent pressure segments (25), each of said pressure segments (25) comprises a core (40) with a cavity (42) having two parallel planar inner faces (41) in sliding contact with said planar outer faces (11) of the support bar (10), and an outer cylindrical surface (21) rotatably mounted on said core (40) and opposite an outer cylindrical surface of at least one reel (30), said planar faces (11, 41) forming guide means for guiding movements of the pressure segments (25) in a radial direction in relation to said support bar (10);

15 a plurality of thrust members (50), each associated to one core (40) and each having a guide portion (51) inserted in said housing (12) of the support bar (10) such that it can slide outwardly and inwardly thereof in a direction parallel to the two planar outer faces (11) of the support bar (10), and a projecting portion (52) arranged for applying pressure against an inner surface of said cavity (42) of the core (40) of the pressure segment (25) when said thrust member  
20 (50) is moved outwardly from the housing (12); and

thrust means in the form of a an expandable sleeve (60) arranged in said housing (12) along the support bar (10) between a bottom surface of the housing (12) and an end surface of each of said guide portions (51) of the thrust members (50), said expandable sleeve (60) being able to be expanded by a pressurized fluid for individually thrusting the pressure segments (25)  
25 against the at least one reel (30) with a common pressure;

characterized in that:

the thrust member (50) has protuberances (53) formed next to an inner end of the guide portion (51), and said longitudinal opening of the housing (12) of the support bar (10) has flanges interfering with said protuberances (53), so that the thrust member (50) is retained in the housing  
30 (12) with limited sliding possibility; and

the longitudinal opening of the housing (12) has a widening (13) located in at least one end of the support bar (10) projecting from the pressure roller (20), said widening (13) having a sufficient size to allow the passage of the guide portions (51) and protuberances (53) of the thrust members (50).

35 2.- The device according to claim 1, characterized in that a stop (14) is fixed inside a portion of the housing (12) of the support bar (10) opposite said widening (13) for retaining the

thrust members (50) inside the housing (12) against a movement in the direction of a central line (15) of the support bar (10).

3.- The device according to claim 2, characterized in that each pressure segment (25) is rotatably mounted on its corresponding core (40) by means of at least one bearing (26), which is  
5 further configured for retaining the pressure segment (25) on its corresponding core (40) against movements in an axial direction.

4.- The device according to claim 3, characterized in that at least one separator (27) is arranged between each pair of adjacent pressure segments (25), said at least one separator (27) being fixed to the core (40) of one of the two adjacent pressure segments (25) and in sliding  
10 contact with a side surface of the core (40) of the other one of the two adjacent pressure segments (25).

5.- The device according to claim 4, characterized in that at least one stop (28) is arranged next to each of the two pressure segments (25) located at the ends of the pressure roller (20), said at least one stop (28) being fixed to one of the planar outer faces (11) of the support bar  
15 (10) and in sliding contact with a side surface of the core (40) of the corresponding pressure segment (25).

6.- The device according to claim 4 or 5, characterized in that said separators (27) and/or said stops (28) are made of a material with a low coefficient of friction.

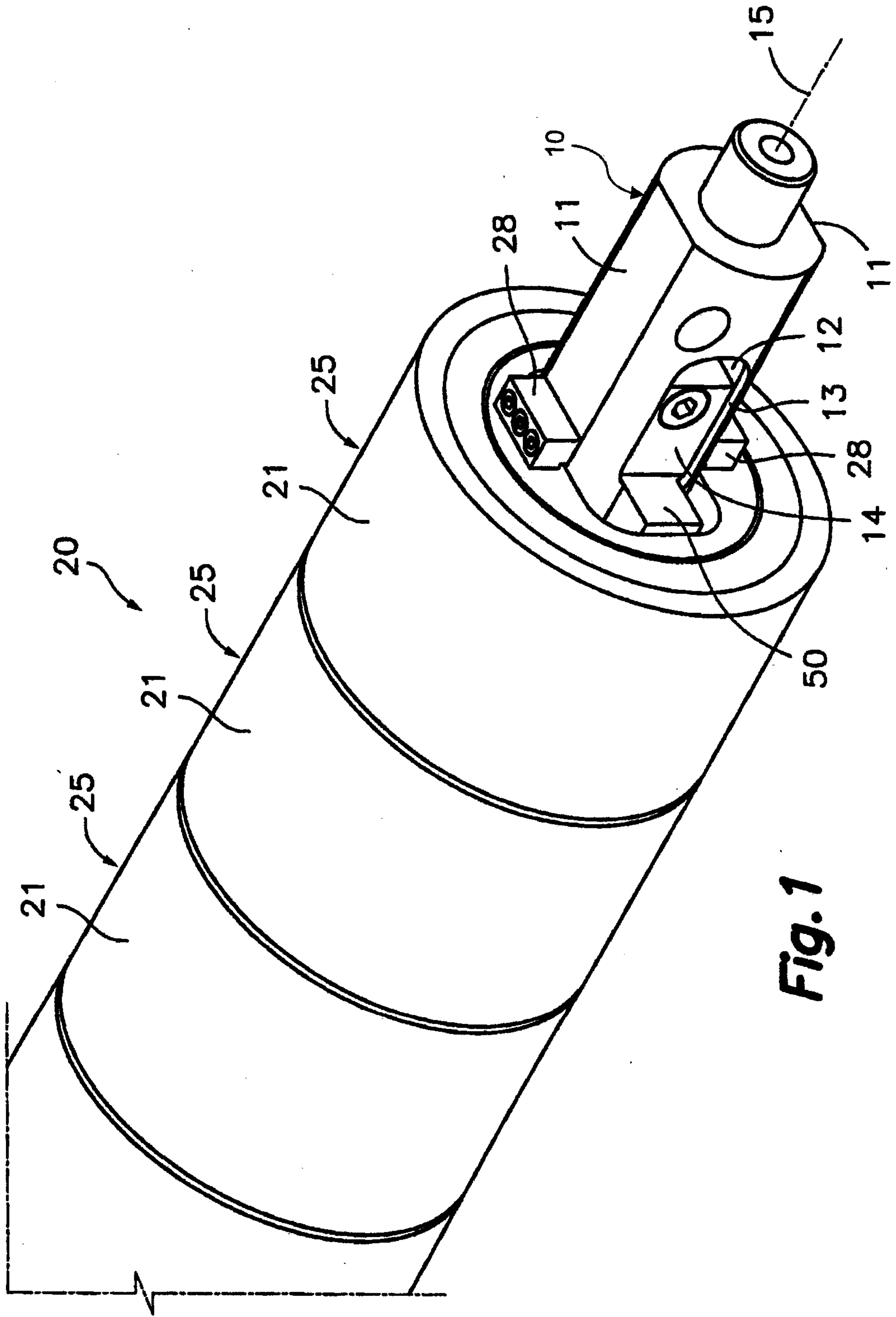

**Fig. 1**

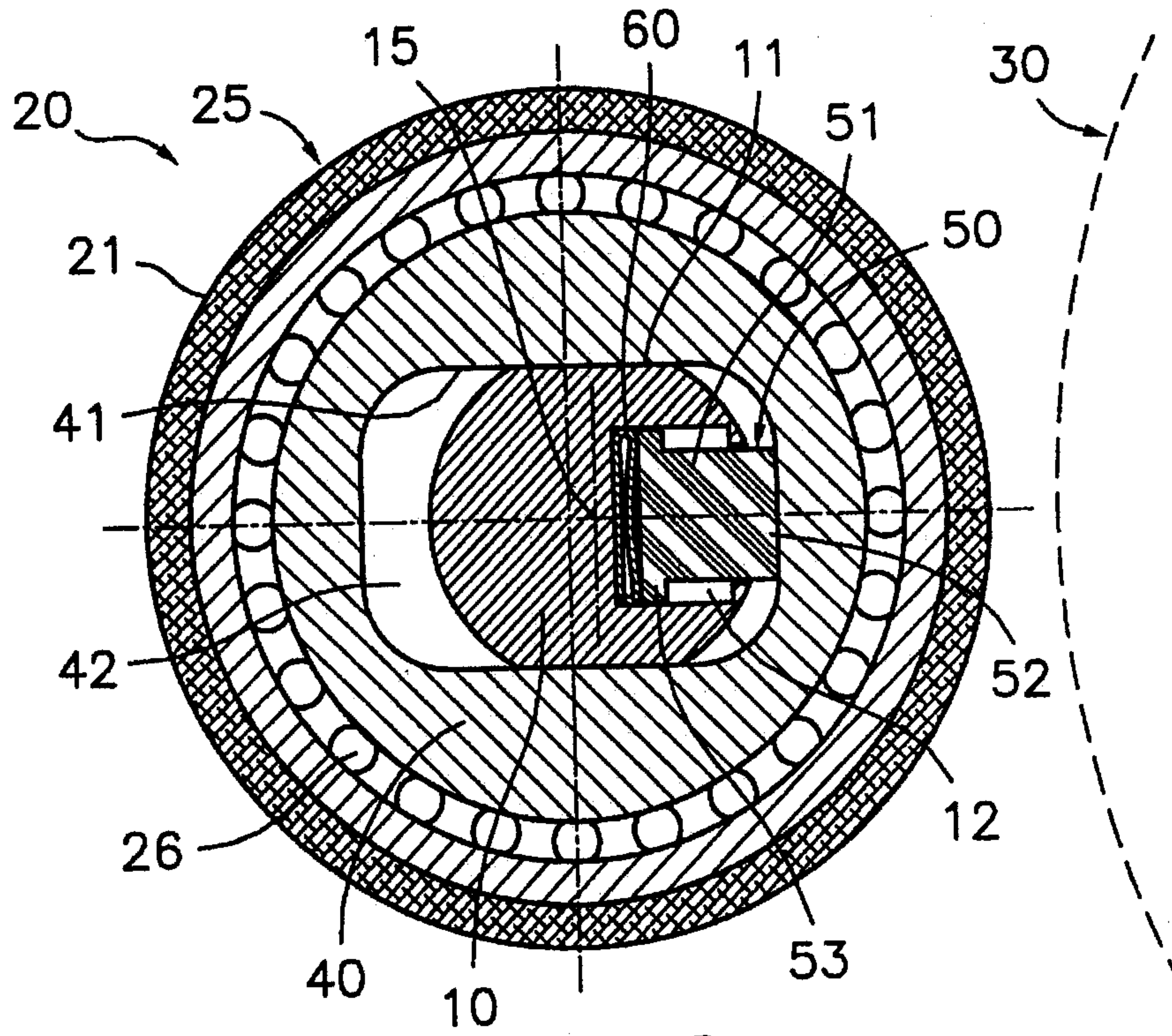

**Fig. 2**

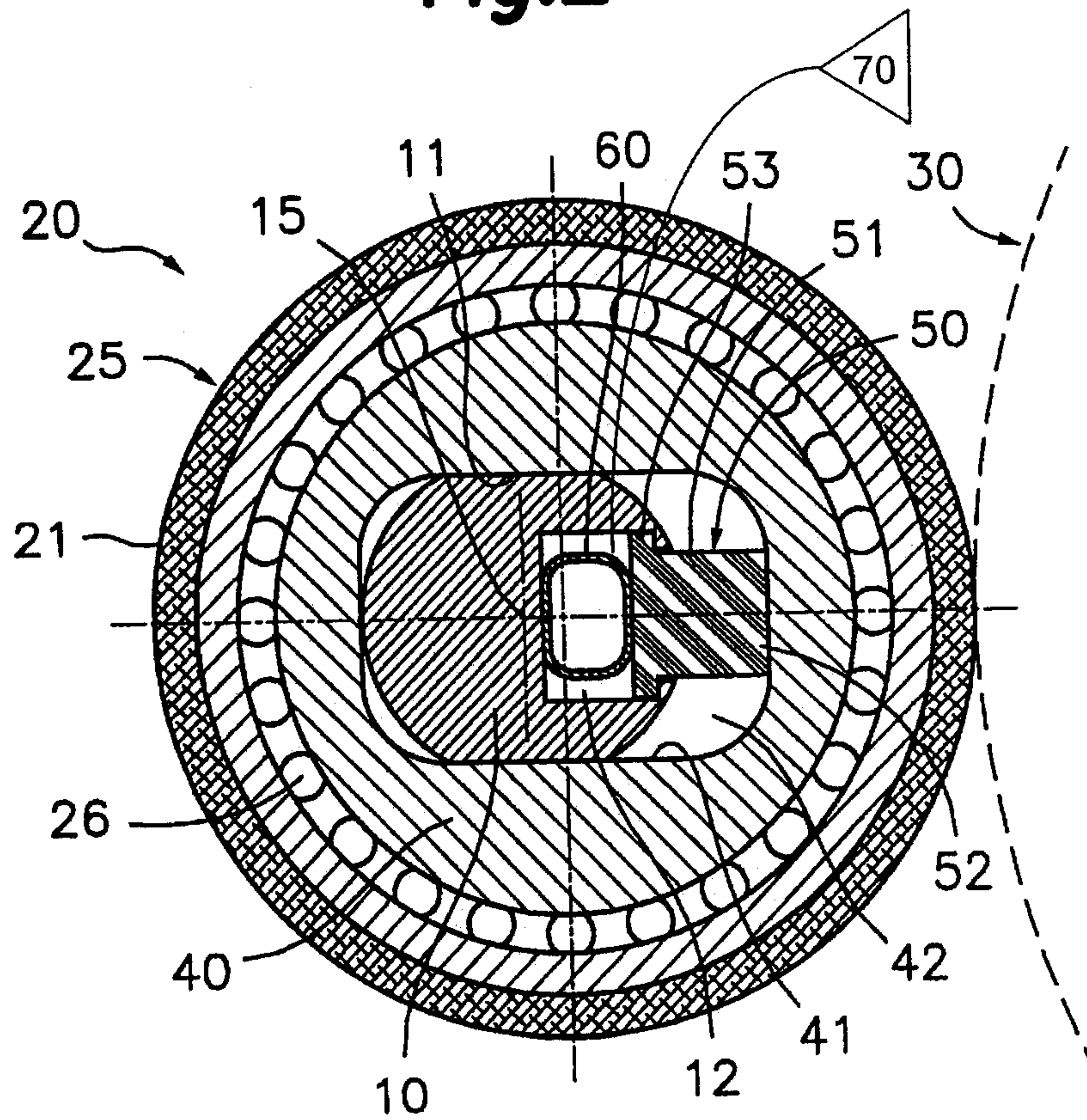

**Fig. 3**



