

(19) World Intellectual Property Organization
International Bureau



(43) International Publication Date
16 May 2002 (16.05.2002)

PCT

(10) International Publication Number
WO 02/39666 A2

(51) International Patent Classification⁷: H04L 12/00

(21) International Application Number: PCT/US01/45837

(22) International Filing Date:
2 November 2001 (02.11.2001)

(25) Filing Language: English

(26) Publication Language: English

(30) Priority Data:
60/246,401 7 November 2000 (07.11.2000) US
09/797,200 1 March 2001 (01.03.2001) US
60/285,211 20 April 2001 (20.04.2001) US
60/291,073 15 May 2001 (15.05.2001) US
09/879,810 12 June 2001 (12.06.2001) US

(71) Applicant: SURGIENT NETWORKS, INC. [US/US];
8303 North Mopac, Suite C-300, Austin, TX 78759 (US).

(72) Inventors: JOHNSON, Scott, C.; 3612 Galena Hills
Loop, Round Rock, TX 78681 (US). FERNANDER,
Robert, B.; 3610 Bonnie Road, Austin, TX 78703 (US).

HARTSELL, Neal, D.; 2705 Clearview Drive, Austin,
TX 78707 (US). JACKSON, Gregory, J.; 501 Madrone
Canyon Drive, Dripping Springs, TX 78620 (US). QIU,
Chaoxin, C.; 10720 Bramblecrest Drive, Austin, TX
78726 (US). RICHTER, Roger, K.; 15248 Faubion Trail,
Leander, TX 78641 (US).

(74) Agent: ENDERS, William, W.; O'keefe, Egan & Peter-
man, Llp, 1101 Capital of Texas Hwy. South, Suite C-200,
Austin, TX 78746 (US).

(81) Designated States (national): AE, AG, AL, AM, AT, AU,
AZ, BA, BB, BG, BR, BY, BZ, CA, CH, CN, CO, CR, CU,
CZ, DE, DK, DM, DZ, EC, EE, ES, FI, GB, GD, GE, GH,
GM, HR, HU, ID, IL, IN, IS, JP, KE, KG, KP, KR, KZ, LC,
LK, LR, LS, LT, LU, LV, MA, MD, MG, MK, MN, MW,
MX, MZ, NO, NZ, PH, PL, PT, RO, RU, SD, SE, SG, SI,
SK, SL, TJ, TM, TR, TT, TZ, UA, UG, UZ, VN, YU, ZA,
ZW.

(84) Designated States (regional): ARIPO patent (GH, GM,
KE, LS, MW, MZ, SD, SL, SZ, TZ, UG, ZW), Eurasian
patent (AM, AZ, BY, KG, KZ, MD, RU, TJ, TM), European
patent (AT, BE, CH, CY, DE, DK, ES, FI, FR, GB, GR, IE,
IT, LU, MC, NL, PT, SE, TR), OAPI patent (BF, BJ, CF,

[Continued on next page]

(54) Title: SYSTEMS AND METHODS FOR PROVIDING DIFFERENTIATED SERVICE IN INFORMATION MANAGEMENT ENVIRONMENTS

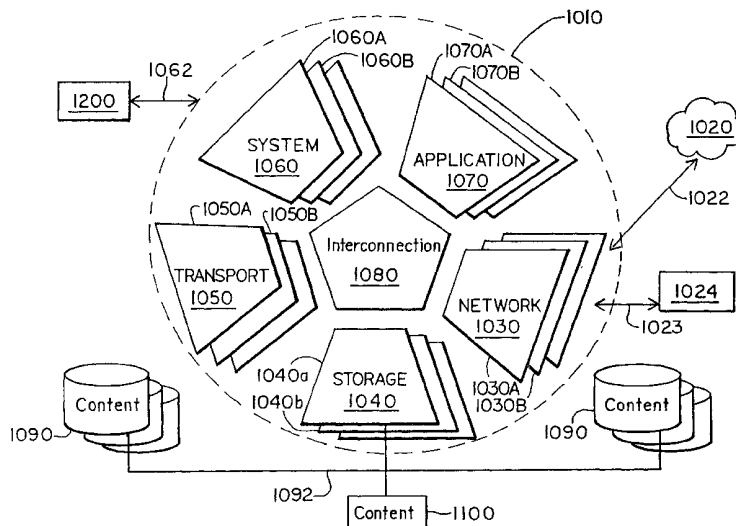

(57) Abstract: Methods and systems for providing differentiated service that may be employed, for example, to deliver content or services in a network environment. Differentiated services that may be so delivered include both differentiated information service that may be implemented, for example, at the system and/or processing level, as well as differentiated business service that may be implemented, for example, to differentiate information exchange between different network entities such as different network provider entities, different network user entities, etc. The methods and systems may include or facilitate provisioning of system service parameters such as service level agreement ("SLA") policies and may be employed in network computing system environments to enable differentiated service provisioning, for example, in accordance with business objectives.



WO 02/39666 A2



CG, CI, CM, GA, GN, GQ, GW, ML, MR, NE, SN, TD, — *entirely in electronic form (except for this front page) and
TG). available upon request from the International Bureau*

Published:

— *without international search report and to be republished
upon receipt of that report*

*For two-letter codes and other abbreviations, refer to the "Guid-
ance Notes on Codes and Abbreviations" appearing at the begin-
ning of each regular issue of the PCT Gazette.*

**SYSTEMS AND METHODS FOR PROVIDING DIFFERENTIATED SERVICE IN
INFORMATION MANAGEMENT ENVIRONMENTS**

Applicant: Surgient Networks, Inc.

5 **Inventors:** Scott C. Johnson, Robert B. Fernander, Neal D. Hartsell, Gregory J. Jackson,
Chaoxin C. Qiu, and Roger K. Richter

BACKGROUND OF THE INVENTION

The present invention relates generally to computing systems, and more particularly
10 to network connected computing systems.

Most network computing systems, including servers and switches, are typically
provided with a number of subsystems that interact to accomplish the designated task/s of the
individual computing system. Each subsystem within such a network computing system is
15 typically provided with a number of resources that it utilizes to carry out its function. In
operation, one or more of these resources may become a bottleneck as load on the computing
system increases, ultimately resulting in degradation of client connection quality, severance
of one or more client connections, and/or server crashes.

20 Network computing system bottlenecks have traditionally been dealt with by throwing
more resources at the problem. For example, when performance degradation is encountered,
more memory, a faster CPU (central processing unit), multiple CPU's, or more disk drives
are added to the server in an attempt to alleviate the bottlenecks. Such solutions therefore
typically involve spending more money to add more hardware. Besides being expensive and
25 time consuming, the addition of hardware often only serves to push the bottleneck to a
different subsystem or resource.

Issues associated with thin last mile access networks are currently being addressed by
technologies such as DSL and cable modems, while overrun core networks are being
30 improved using, for example, ultra-high speed switching/routing and wave division
multiplexing technologies. However, even with the implementation of such technologies,
end user expectations of service quality per device and content usage experience is often not
met due to network equipment limitations encountered in the face of the total volume of
network usage. Lack of network quality assurance for information management applications
35 such as content delivery makes the implementation of mission-critical or high quality content
delivery undesirable on networks such as the Internet, limiting service growth and

profitability and leaving content delivery and other information management applications as thin profit commodity businesses on such networks.

Often the ultimate network bottleneck is the network server itself. For example, to
5 maintain high-quality service for a premium customer necessarily requires that the traditional
video server be under-utilized so that sufficient bandwidth is available to deliver a premium
video stream without packet loss. However, to achieve efficient levels of utilization the
server must handle multiple user sessions simultaneously, often including both premium and
non-premium video streams. In this situation, the traditional server often becomes
10 overloaded, and delivers all streams with equal packet loss. Thus, the premium customer has
the same low quality experience as a non-premium customer.

A number of standards, protocols and techniques have been developed over the years
to provide varying levels of treatment for different types of traffic on local area networks
15 ("LANs"). These standards have been implemented at many Open System Interconnection
("OSI") levels. For example, Ethernet has priority bits in the 802.1p/q header, and TCP/IP
has TOS bits. Presumably, switches and routers would use these bits to give higher priority
to packets labeled with one set of bits, as opposed to another. RSVP is a signaling protocol
that is used to reserve resources throughout the LAN (from one endpoint to another), so that
20 bandwidth for a connection can be guaranteed. Many of these protocols have being
considered for use within the Internet.

SUMMARY OF THE INVENTION

25 Disclosed herein are systems and methods for the deterministic management of
information, such as management of the delivery of content across a network that utilizes
computing systems such as servers, switches and/or routers. Among the many advantages
provided by the disclosed systems and methods are increased performance and improved
predictability of such computing systems in the performance of designated tasks across a
30 wide range of loads. Examples include greater predictability in the capability of a network
server, switch or router to process and manage information such as content requests, and
acceleration in the delivery of information across a network utilizing such computing
systems.

Deterministic embodiments of the disclosed systems and methods may be implemented to achieve substantial elimination of indeterminate application performance characteristics common with conventional information management systems, such as conventional content delivery infrastructures. For example, the disclosed systems and methods may be advantageously employed to solve unpredictability, delivery latencies, capacity planning, and other problems associated with general application serving in a computer network environment, for example, in the delivery of streaming media, data and/or services. Other advantages and benefits possible with implementation of the disclosed systems and methods include maximization of hardware resource use for delivery of content while at the same time allowing minimization of the need to add expensive hardware across all functional subsystems simultaneously to a content delivery system, and elimination of the need for an application to have intimate knowledge of the hardware it intends to employ by maintaining such knowledge in the operating system of a deterministically enabled computing component.

15

In one exemplary embodiment, the disclosed systems and methods may be employed with network content delivery systems to manage content delivery hardware in a manner to achieve efficient and predictable delivery of content. In another exemplary embodiment, deterministic delivery of data through a content delivery system may be implemented with end-to-end consideration of QoS priority policies within and across all components from storage disk to wide area network (WAN) interface. In yet another exemplary embodiment, delivery of content may be tied to the rate at which the content is delivered from networking components. These and other benefits of the disclosed methods and systems may be achieved, for example, by incorporating intelligence into individual system components.

25

The disclosed systems and methods may be implemented to utilize end-to-end consideration of quality assurance parameters so as to provide scalable and practical mechanisms that allow varying levels of service to be differentially tailored or personalized for individual network users. Consideration of such quality assurance parameters may be used to advantageously provide end-to-end network systems, such as end-to-end content delivery infrastructures, with network-based mechanisms that provide users with class of service ("CoS"), quality of service ("QoS"), connection admission control, *etc.* This ability may be used by service providers ("xSPs") to offer their users premium information management services for premium prices. Examples of such xSPs include, but are not

30

limited to, Internet service providers (“ISPs”), application service providers (“ASPs”), content delivery service providers (“CDSs”), storage service providers (“SSPs”), content providers (“CPs”), Portals, *etc.*

5 Certain embodiments of the disclosed systems and methods may be advantageously employed in network computing system environments to enable differentiated service provisioning, for example, in accordance with business objectives. Examples of types of differentiated service provisioning that may be implemented include, but are not limited to, re-provisioned and real time system resource allocation and management, service, metering,
10 *billing, etc.* In other embodiments disclosed herein, monitoring, tracking and/or reporting features may be implemented in network computing system environments. Advantageously, these functions may be implemented at the resource, platform subsystem, platform, and/or application levels, to fit the needs of particular network environments. In other examples, features that may be implemented include, but are not limited to, system and Service Level
15 Agreement (SLA) performance reporting, content usage tracking and reporting (*e.g.*, identity of content accessed, identity of user accessing the content, bandwidth at which the content is accessed, frequency and/or time of day of access to the content, *etc.*), bill generation and/or billing information reporting, *etc.* Advantageously, the disclosed systems and methods make possible the delivery of such differentiated information management features at the edge of a
20 network (*e.g.*, across single or multiple nodes), for example, by using SLA policies to control system resource allocation to service classes (*e.g.*, packet processing) at the network edge, *etc.*

In one disclosed embodiment, an information management system platform may be
25 provided that is capable of delivering content, applications and/or services to a network with service guarantees specified through policies. Such a system platform may be advantageously employed to provide an overall network infrastructure the ability to provide differentiated services for bandwidth consumptive applications from the xSP standpoint, advantageously allowing implementation of rich media audio and video content delivery
30 applications on such networks.

In a further embodiment disclosed herein, a separate operating system or operating system method may be provided that is inherently optimized to allow standard/traditional network-connected compute system applications (or other applications designed for

traditional I/O intensive environments) to be run without modification on the disclosed systems having multi-layer asymmetrical processing architecture, although optional modifications and further optimization are possible if so desired. Examples include, but are not limited to, applications related to streaming, HTTP, storage networking (network attached
5 storage (NAS), storage area network (SAN), combinations thereof, *etc.*), data base, caching, life sciences, *etc.*

In yet another embodiment disclosed herein, a utility-based computing process may be implemented to manage information and provide differentiated service using a process that
10 includes provisioning of resources (*e.g.*, based on SLA policies), tracking and logging of provisioning statistics (*e.g.*, to measure how well SLA policies have been met), and transmission of periodic logs to a billing system (*e.g.*, for SLA verification, future resource allocation, bill generation, *etc.*). Such a process may also be implemented so as to be scalable to bandwidth requirements (network (NET), compute, storage elements, *etc.*), may be
15 deterministic at various system levels (below the operating system level, at the application level, at the subsystem or subscriber flow level, *etc.*), may be implemented across all applications hosted (HTTP, RTSP, NFS, *etc.*), as well as across multiple users and multiple applications, systems, and operating system configurations.

Advantageously, the scalable and deterministic aspects of certain embodiments
20 disclosed herein may be implemented in a way so as to offer surprising and significant advantages with regard to differentiated service, while at the same time providing reduced total cost of system use, and increased performance for system cost relative to traditional computing and network systems. Further, these scalable and deterministic features may be
25 used to provide information management systems capable of performing differentiated service functions or tasks such as service prioritization, monitoring, and reporting functions in a fixed hardware implementation platform, variable hardware implementation platform or distributed set of platforms (either full system or distributed subsystems across a network), and which may be further configured to be capable of delivering such features at the edge of
30 a network in a manner that is network transport independent.

In one specific example, deterministic management of information may be implemented to extend network traffic management principles to achieve a true end-to-end quality experience, for example, all the way to the stored content in a content delivery system

environment. For example, the disclosed systems and methods may be implemented in one embodiment to provide differentiated service functions or tasks (*e.g.*, that may be content-aware, user-aware, application-aware, *etc.*) in a storage spindle-to-WAN edge router environment, and in doing so make possible the delivery of differentiated information
5 services and/or differentiated business services.

BRIEF DESCRIPTION OF THE DRAWINGS

FIG. 1A is a representation of components of a content delivery system according to
10 one embodiment of the disclosed content delivery system.

FIG. 1B is a representation of data flow between modules of a content delivery system of FIGURE 1A according to one embodiment of the disclosed content delivery system.
15

FIG. 1C is a simplified schematic diagram showing one possible network content delivery system hardware configuration.

FIG. 1D is a simplified schematic diagram showing a network content delivery engine
20 configuration possible with the network content delivery system hardware configuration of FIG. 1C.

FIG. 1E is a simplified schematic diagram showing an alternate network content delivery engine configuration possible with the network content delivery system hardware
25 configuration of FIG. 1C.

FIG. 1F is a simplified schematic diagram showing another alternate network content delivery engine configuration possible with the network content delivery system hardware configuration of FIG. 1C.
30

FIGS. 1G-1J illustrate exemplary clusters of network content delivery systems.

FIG. 2 is a simplified schematic diagram showing another possible network content delivery system configuration.

FIG. 2A is a simplified schematic diagram showing a network endpoint computing system.

5 FIG. 2B is a simplified schematic diagram showing a network endpoint computing system.

FIG. 3 is a functional block diagram of an exemplary network processor.

10 FIG. 4 is a functional block diagram of an exemplary interface between a switch fabric and a processor.

FIG. 5 is a flow chart illustrating a method for the deterministic delivery of content according to one embodiment of the present invention.

15

FIG. 6 is a simplified schematic diagram illustrating a data center operable to perform deterministic delivery of content according to one embodiment of the present invention.

20 FIG. 7 is a simplified representation illustrating interrelation of various functional components of an information management system and method for delivering differentiated service according to one embodiment of the present invention.

FIG. 8 is a flow chart illustrating a method of providing differentiated service based on defined business objectives according to one embodiment of the present invention.

25

FIG. 9A is a simplified representation illustrating an endpoint information management node and data center connected to a network according to one embodiment of the disclosed content delivery system.

30 FIG. 9B is a simplified representation illustrating a traffic management node connected to a network according to one embodiment of the disclosed content delivery system.

FIG. 9C is a simplified representation of multiple edge content delivery nodes connected to a network according to one embodiment of the disclosed content delivery system.

5 FIG. 9D is a representation of components of an information management system interconnected across a network according to one embodiment of the disclosed content delivery system.

10 DESCRIPTION OF ILLUSTRATIVE EMBODIMENTS

Disclosed herein are systems and methods for operating network connected computing systems. The network connected computing systems disclosed provide a more efficient use of computing system resources and provide improved performance as compared to traditional network connected computing systems. Network connected computing systems
15 may include network endpoint systems. The systems and methods disclosed herein may be particularly beneficial for use in network endpoint systems. Network endpoint systems may include a wide variety of computing devices, including but not limited to, classic general purpose servers, specialized servers, network appliances, storage area networks or other storage medium, content delivery systems, corporate data centers, application service
20 providers, home or laptop computers, clients, any other device that operates as an endpoint network connection, etc.

Other network connected systems may be considered a network intermediate node system. Such systems are generally connected to some node of a network that may operate in
25 some other fashion than an endpoint. Typical examples include network switches or network routers. Network intermediate node systems may also include any other devices coupled to intermediate nodes of a network.

Further, some devices may be considered both a network intermediate node system
30 and a network endpoint system. Such hybrid systems may perform both endpoint functionality and intermediate node functionality in the same device. For example, a network switch that also performs some endpoint functionality may be considered a hybrid system. As used herein such hybrid devices are considered to be a network endpoint system and are also considered to be a network intermediate node system.

For ease of understanding, the systems and methods disclosed herein are described with regards to an illustrative network connected computing system. In the illustrative example the system is a network endpoint system optimized for a content delivery application. Thus a content delivery system is provided as an illustrative example that demonstrates the structures, methods, advantages and benefits of the network computing system and methods disclosed herein. Content delivery systems (such as systems for serving streaming content, HTTP content, cached content, etc.) generally have intensive input/output demands.

10

It will be recognized that the hardware and methods discussed below may be incorporated into other hardware or applied to other applications. For example with respect to hardware, the disclosed system and methods may be utilized in network switches. Such switches may be considered to be intelligent or smart switches with expanded functionality beyond a traditional switch. Referring to the content delivery application described in more detail herein, a network switch may be configured to also deliver at least some content in addition to traditional switching functionality. Thus, though the system may be considered primarily a network switch (or some other network intermediate node device), the system may incorporate the hardware and methods disclosed herein. Likewise a network switch performing applications other than content delivery may utilize the systems and methods disclosed herein. The nomenclature used for devices utilizing the concepts of the present invention may vary. The network switch or router that includes the content delivery system disclosed herein may be called a network content switch or a network content router or the like. Independent of the nomenclature assigned to a device, it will be recognized that the network device may incorporate some or all of the concepts disclosed herein.

25

The disclosed hardware and methods also may be utilized in storage area networks, network attached storage, channel attached storage systems, disk arrays, tape storage systems, direct storage devices or other storage systems. In this case, a storage system having the traditional storage system functionality may also include additional functionality utilizing the hardware and methods shown herein. Thus, although the system may primarily be considered a storage system, the system may still include the hardware and methods disclosed herein. The disclosed hardware and methods of the present invention also may be utilized in traditional personal computers, portable computers, servers, workstations, mainframe

30

computer systems, or other computer systems. In this case, a computer system having the traditional computer system functionality associated with the particular type of computer system may also include additional functionality utilizing the hardware and methods shown herein. Thus, although the system may primarily be considered to be a particular type of
5 computer system, the system may still include the hardware and methods disclosed herein.

As mentioned above, the benefits of the present invention are not limited to any specific tasks or applications. The content delivery applications described herein are thus illustrative only. Other tasks and applications that may incorporate the principles of the
10 present invention include, but are not limited to, database management systems, application service providers, corporate data centers, modeling and simulation systems, graphics rendering systems, other complex computational analysis systems, etc. Although the principles of the present invention may be described with respect to a specific application, it will be recognized that many other tasks or applications performed with the hardware and
15 methods.

Disclosed herein are systems and methods for delivery of content to computer-based networks that employ functional multi-processing using a "staged pipeline" content delivery environment to optimize bandwidth utilization and accelerate content delivery while allowing
20 greater determination in the data traffic management. The disclosed systems may employ individual modular processing engines that are optimized for different layers of a software stack. Each individual processing engine may be provided with one or more discrete subsystem modules configured to run on their own optimized platform and/or to function in parallel with one or more other subsystem modules across a high speed distributive
25 interconnect, such as a switch fabric, that allows peer-to-peer communication between individual subsystem modules. The use of discrete subsystem modules that are distributively interconnected in this manner advantageously allows individual resources (*e.g.*, processing resources, memory resources) to be deployed by sharing or reassignment in order to maximize acceleration of content delivery by the content delivery system. The use of a
30 scalable packet-based interconnect, such as a switch fabric, advantageously allows the installation of additional subsystem modules without significant degradation of system performance. Furthermore, policy enhancement/enforcement may be optimized by placing intelligence in each individual modular processing engine.

The network systems disclosed herein may operate as network endpoint systems. Examples of network endpoints include, but are not limited to, servers, content delivery systems, storage systems, application service providers, database management systems, corporate data center servers, etc. A client system is also a network endpoint, and its
5 resources may typically range from those of a general purpose computer to the simpler resources of a network appliance. The various processing units of the network endpoint system may be programmed to achieve the desired type of endpoint.

Some embodiments of the network endpoint systems disclosed herein are network
10 endpoint content delivery systems. The network endpoint content delivery systems may be utilized in replacement of or in conjunction with traditional network servers. A "server" can be any device that delivers content, services, or both. For example, a content delivery server receives requests for content from remote browser clients via the network, accesses a file system to retrieve the requested content, and delivers the content to the client. As another
15 example, an applications server may be programmed to execute applications software on behalf of a remote client, thereby creating data for use by the client. Various server appliances are being developed and often perform specialized tasks.

As will be described more fully below, the network endpoint system disclosed herein
20 may include the use of network processors. Though network processors conventionally are designed and utilized at intermediate network nodes, the network endpoint system disclosed herein adapts this type of processor for endpoint use.

The network endpoint system disclosed may be construed as a switch based
25 computing system. The system may further be characterized as an asymmetric multi-processor system configured in a staged pipeline manner.

EXEMPLARY SYSTEM OVERVIEW

FIG. 1A is a representation of one embodiment of a content delivery system 1010, for
30 example as may be employed as a network endpoint system in connection with a network 1020. Network 1020 may be any type of computer network suitable for linking computing systems. Content delivery system 1010 may be coupled to one or more networks including, but not limited to, the public internet, a private intranet network (e.g., linking users and hosts such as employees of a corporation or institution), a wide area network (WAN), a local area

network (LAN), a wireless network, any other client based network or any other network environment of connected computer systems or online users. Thus, the data provided from the network 1020 may be in any networking protocol. In one embodiment, network 1020 may be the public internet that serves to provide access to content delivery system 1010 by multiple online users that utilize internet web browsers on personal computers operating through an internet service provider. In this case the data is assumed to follow one or more of various Internet Protocols, such as TCP/IP, UDP, HTTP, RTSP, SSL, FTP, etc. However, the same concepts apply to networks using other existing or future protocols, such as IPX, SNMP, NetBios, Ipv6, etc. The concepts may also apply to file protocols such as network file system (NFS) or common internet file system (CIFS) file sharing protocol.

Examples of content that may be delivered by content delivery system 1010 include, but are not limited to, static content (*e.g.*, web pages, MP3 files, HTTP object files, audio stream files, video stream files, *etc.*), dynamic content, *etc.* In this regard, static content may be defined as content available to content delivery system 1010 via attached storage devices and as content that does not generally require any processing before delivery. Dynamic content, on the other hand, may be defined as content that either requires processing before delivery, or resides remotely from content delivery system 1010. As illustrated in FIG. 1A, content sources may include, but are not limited to, one or more storage devices 1090 (magnetic disks, optical disks, tapes, storage area networks (SAN's), *etc.*), other content sources 1100, third party remote content feeds, broadcast sources (live direct audio or video broadcast feeds, *etc.*), delivery of cached content, combinations thereof, *etc.* Broadcast or remote content may be advantageously received through second network connection 1023 and delivered to network 1020 via an accelerated flowpath through content delivery system 1010. As discussed below, second network connection 1023 may be connected to a second network 1024 (as shown). Alternatively, both network connections 1022 and 1023 may be connected to network 1020.

As shown in FIG. 1A, one embodiment of content delivery system 1010 includes multiple system engines 1030, 1040, 1050, 1060, and 1070 communicatively coupled via distributive interconnection 1080. In the exemplary embodiment provided, these system engines operate as content delivery engines. As used herein, "content delivery engine" generally includes any hardware, software or hardware/software combination capable of performing one or more dedicated tasks or sub-tasks associated with the delivery or

transmittal of content from one or more content sources to one or more networks. In the embodiment illustrated in FIG. 1A content delivery processing engines (or "processing blades") include network interface processing engine 1030, storage processing engine 1040, network transport / protocol processing engine 1050 (referred to hereafter as a transport processing engine), system management processing engine 1060, and application processing engine 1070. Thus configured, content delivery system 1010 is capable of providing multiple dedicated and independent processing engines that are optimized for networking, storage and application protocols, each of which is substantially self-contained and therefore capable of functioning without consuming resources of the remaining processing engines.

10

It will be understood with benefit of this disclosure that the particular number and identity of content delivery engines illustrated in FIG. 1A are illustrative only, and that for any given content delivery system 1010 the number and/or identity of content delivery engines may be varied to fit particular needs of a given application or installation. Thus, the number of engines employed in a given content delivery system may be greater or fewer in number than illustrated in FIG. 1A, and/or the selected engines may include other types of content delivery engines and/or may not include all of the engine types illustrated in FIG. 1A. In one embodiment, the content delivery system 1010 may be implemented within a single chassis, such as for example, a 2U chassis.

20

Content delivery engines 1030, 1040, 1050, 1060 and 1070 are present to independently perform selected sub-tasks associated with content delivery from content sources 1090 and/or 1100, it being understood however that in other embodiments any one or more of such subtasks may be combined and performed by a single engine, or subdivided to be performed by more than one engine. In one embodiment, each of engines 1030, 1040, 1050, 1060 and 1070 may employ one or more independent processor modules (*e.g.*, CPU modules) having independent processor and memory subsystems and suitable for performance of a given function/s, allowing independent operation without interference from other engines or modules. Advantageously, this allows custom selection of particular processor-types based on the particular sub-task each is to perform, and in consideration of factors such as speed or efficiency in performance of a given subtask, cost of individual processor, *etc.* The processors utilized may be any processor suitable for adapting to endpoint processing. Any "PC on a board" type device may be used, such as the x86 and Pentium processors from Intel Corporation, the SPARC processor from Sun Microsystems,

30

Inc., the PowerPC processor from Motorola, Inc. or any other microcontroller or microprocessor. In addition, network processors (discussed in more detail below) may also be utilized. The modular multi-task configuration of content delivery system 1010 allows the number and/or type of content delivery engines and processors to be selected or varied to fit
5 the needs of a particular application.

The configuration of the content delivery system described above provides scalability without having to scale all the resources of a system. Thus, unlike the traditional rack and stack systems, such as server systems in which an entire server may be added just to expand
10 one segment of system resources, the content delivery system allows the particular resources needed to be the only expanded resources. For example, storage resources may be greatly expanded without having to expand all of the traditional server resources.

DISTRIBUTIVE INTERCONNECT

15 Still referring to FIG. 1A, distributive interconnection 1080 may be any multi-node I/O interconnection hardware or hardware/software system suitable for distributing functionality by selectively interconnecting two or more content delivery engines of a content delivery system including, but not limited to, high speed interchange systems such as a switch fabric or bus architecture. Examples of switch fabric architectures include cross-bar switch
20 fabrics, Ethernet switch fabrics, ATM switch fabrics, etc. Examples of bus architectures include PCI, PCI-X, S-Bus, Microchannel, VME, etc. Generally, for purposes of this description, a "bus" is any system bus that carries data in a manner that is visible to all nodes on the bus. Generally, some sort of bus arbitration scheme is implemented and data may be carried in parallel, as n-bit words. As distinguished from a bus, a switch fabric establishes
25 independent paths from node to node and data is specifically addressed to a particular node on the switch fabric. Other nodes do not see the data nor are they blocked from creating their own paths. The result is a simultaneous guaranteed bit rate in each direction for each of the switch fabric's ports.

30 The use of a distributed interconnect 1080 to connect the various processing engines in lieu of the network connections used with the switches of conventional multi-server endpoints is beneficial for several reasons. As compared to network connections, the distributed interconnect 1080 is less error prone, allows more deterministic content delivery, and provides higher bandwidth connections to the various processing engines. The distributed

interconnect 1080 also has greatly improved data integrity and throughput rates as compared to network connections.

Use of the distributed interconnect 1080 allows latency between content delivery engines to be short, finite and follow a known path. Known maximum latency specifications are typically associated with the various bus architectures listed above. Thus, when the employed interconnect medium is a bus, latencies fall within a known range. In the case of a switch fabric, latencies are fixed. Further, the connections are "direct", rather than by some undetermined path. In general, the use of the distributed interconnect 1080 rather than network connections, permits the switching and interconnect capacities of the content delivery system 1010 to be predictable and consistent.

One example interconnection system suitable for use as distributive interconnection 1080 is an 8/16 port 28.4 Gbps high speed PRIZMA-E non-blocking switch fabric switch available from IBM. It will be understood that other switch fabric configurations having greater or lesser numbers of ports, throughput, and capacity are also possible. Among the advantages offered by such a switch fabric interconnection in comparison to shared-bus interface interconnection technology are throughput, scalability and fast and efficient communication between individual discrete content delivery engines of content delivery system 1010. In the embodiment of FIG. 1A, distributive interconnection 1080 facilitates parallel and independent operation of each engine in its own optimized environment without bandwidth interference from other engines, while at the same time providing peer-to-peer communication between the engines on an as-needed basis (*e.g.*, allowing direct communication between any two content delivery engines 1030, 1040, 1050, 1060 and 1070). Moreover, the distributed interconnect may directly transfer inter-processor communications between the various engines of the system. Thus, communication, command and control information may be provided between the various peers via the distributed interconnect. In addition, communication from one peer to multiple peers may be implemented through a broadcast communication which is provided from one peer to all peers coupled to the interconnect. The interface for each peer may be standardized, thus providing ease of design and allowing for system scaling by providing standardized ports for adding additional peers.

NETWORK INTERFACE PROCESSING ENGINE

As illustrated in FIG. 1A, network interface processing engine 1030 interfaces with network 1020 by receiving and processing requests for content and delivering requested content to network 1020. Network interface processing engine 1030 may be any hardware or hardware/software subsystem suitable for connections utilizing TCP (Transmission Control Protocol) IP (Internet Protocol), UDP (User Datagram Protocol), RTP (Real-Time Transport Protocol), Internet Protocol (IP), Wireless Application Protocol (WAP) as well as other networking protocols. Thus the network interface processing engine 1030 may be suitable for handling queue management, buffer management, TCP connect sequence, checksum, IP address lookup, internal load balancing, packet switching, *etc.* Thus, network interface processing engine 1030 may be employed as illustrated to process or terminate one or more layers of the network protocol stack and to perform look-up intensive operations, offloading these tasks from other content delivery processing engines of content delivery system 1010. Network interface processing engine 1030 may also be employed to load balance among other content delivery processing engines of content delivery system 1010. Both of these features serve to accelerate content delivery, and are enhanced by placement of distributive interchange and protocol termination processing functions on the same board. Examples of other functions that may be performed by network interface processing engine 1030 include, but are not limited to, security processing.

20

With regard to the network protocol stack, the stack in traditional systems may often be rather large. Processing the entire stack for every request across the distributed interconnect may significantly impact performance. As described herein, the protocol stack has been segmented or "split" between the network interface engine and the transport processing engine. An abbreviated version of the protocol stack is then provided across the interconnect. By utilizing this functionally split version of the protocol stack, increased bandwidth may be obtained. In this manner the communication and data flow through the content delivery system 1010 may be accelerated. The use of a distributed interconnect (for example a switch fabric) further enhances this acceleration as compared to traditional bus interconnects.

30

The network interface processing engine 1030 may be coupled to the network 1020 through a Gigabit (Gb) Ethernet fiber front end interface 1022. One or more additional Gb Ethernet interfaces 1023 may optionally be provided, for example, to form a second interface

with network 1020, or to form an interface with a second network or application 1024 as shown (*e.g.*, to form an interface with one or more server/s for delivery of web cache content, *etc.*). Regardless of whether the network connection is via Ethernet, or some other means, the network connection could be of any type, with other examples being ATM, SONET, or
5 wireless. The physical medium between the network and the network processor may be copper, optical fiber, wireless, etc.

In one embodiment, network interface processing engine 1030 may utilize a network processor, although it will be understood that in other embodiments a network processor may
10 be supplemented with or replaced by a general purpose processor or an embedded microcontroller. The network processor may be one of the various types of specialized processors that have been designed and marketed to switch network traffic at intermediate nodes. Consistent with this conventional application, these processors are designed to process high speed streams of network packets. In conventional operation, a network
15 processor receives a packet from a port, verifies fields in the packet header, and decides on an outgoing port to which it forwards the packet. The processing of a network processor may be considered as "pass through" processing, as compared to the intensive state modification processing performed by general purpose processors. A typical network processor has a number of processing elements, some operating in parallel and some in pipeline. Often a
20 characteristic of a network processor is that it may hide memory access latency needed to perform lookups and modifications of packet header fields. A network processor may also have one or more network interface controllers, such as a gigabit Ethernet controller, and are generally capable of handling data rates at "wire speeds".

25 Examples of network processors include the C-Port processor manufactured by Motorola, Inc., the IXP1200 processor manufactured by Intel Corporation, the Prism processor manufactured by SiTera Inc., and others manufactured by MMC Networks, Inc. and Agere, Inc. These processors are programmable, usually with a RISC or augmented RISC instruction set, and are typically fabricated on a single chip.

30

The processing cores of a network processor are typically accompanied by special purpose cores that perform specific tasks, such as fabric interfacing, table lookup, queue management, and buffer management. Network processors typically have their memory management optimized for data movement, and have multiple I/O and memory buses. The

programming capability of network processors permit them to be programmed for a variety of tasks, such as load balancing, network protocol processing, network security policies, and QoS/CoS support. These tasks can be tasks that would otherwise be performed by another processor. For example, TCP/IP processing may be performed by a network processor at the front end of an endpoint system. Another type of processing that could be offloaded is execution of network security policies or protocols. A network processor could also be used for load balancing. Network processors used in this manner can be referred to as “network accelerators” because their front end “look ahead” processing can vastly increase network response speeds. Network processors perform look ahead processing by operating at the front end of the network endpoint to process network packets in order to reduce the workload placed upon the remaining endpoint resources. Various uses of network accelerators are described in the following U.S. patent applications: Serial No. 09/797,412, filed March 1, 2001 and entitled “Network Transport Accelerator,” by Bailey et. al; Serial No. 09/797,507 filed March 1, 2001 and entitled “Single Chassis Network Endpoint System With Network Processor For Load Balancing,” by Richter et. al; and Serial No. 09/797,411 filed March 1, 2001 and entitled “Network Security Accelerator,” by Canion et. al; the disclosures of which are all incorporated herein by reference. When utilizing network processors in an endpoint environment it may be advantageous to utilize techniques for order serialization of information, such as for example, as disclosed in U.S. patent application Serial No. 09/797,197, filed March 1, 2001 and entitled “Methods and Systems For The Order Serialization Of Information In A Network Processing Environment,” by Richter et. al, the disclosure of which is incorporated herein by reference.

FIG. 3 illustrates one possible general configuration of a network processor. As illustrated, a set of traffic processors 21 operate in parallel to handle transmission and receipt of network traffic. These processors may be general purpose microprocessors or state machines. Various core processors 22 - 24 handle special tasks. For example, the core processors 22 - 24 may handle lookups, checksums, and buffer management. A set of serial data processors 25 provide Layer 1 network support. Interface 26 provides the physical interface to the network 1020. A general purpose bus interface 27 is used for downloading code and configuration tasks. A specialized interface 28 may be specially programmed to optimize the path between network processor 12 and distributed interconnection 1080.

As mentioned above, the network processors utilized in the content delivery system 1010 are utilized for endpoint use, rather than conventional use at intermediate network nodes. In one embodiment, network interface processing engine 1030 may utilize a MOTOROLA C-Port C-5 network processor capable of handling two Gb Ethernet interfaces at wire speed, and optimized for cell and packet processing. This network processor may contain sixteen 200 MHz MIPS processors for cell/packet switching and thirty-two serial processing engines for bit/byte processing, checksum generation/verification, etc. Further processing capability may be provided by five co-processors that perform the following network specific tasks: supervisor/executive, switch fabric interface, optimized table lookup, queue management, and buffer management. The network processor may be coupled to the network 1020 by using a VITESSE GbE SERDES (serializer-deserializer) device (for example the VSC7123) and an SFP (small form factor pluggable) optical transceiver for LC fiber connection.

15 TRANSPORT / PROTOCOL PROCESSING ENGINE

Referring again to FIG. 1A, transport processing engine 1050 may be provided for performing network transport protocol sub-tasks, such as processing content requests received from network interface engine 1030. Although named a "transport" engine for discussion purposes, it will be recognized that the engine 1050 performs transport and protocol processing and the term transport processing engine is not meant to limit the functionality of the engine. In this regard transport processing engine 1050 may be any hardware or hardware/software subsystem suitable for TCP/UDP processing, other protocol processing, transport processing, etc. In one embodiment transport engine 1050 may be a dedicated TCP/UDP processing module based on an INTEL PENTIUM III or MOTOROLA POWERPC 7450 based processor running the Thread-X RTOS environment with protocol stack based on TCP/IP technology.

As compared to traditional server type computing systems, the transport processing engine 1050 may off-load other tasks that traditionally a main CPU may perform. For example, the performance of server CPUs significantly decreases when a large amount of network connections are made merely because the server CPU regularly checks each connection for time outs. The transport processing engine 1050 may perform time out checks for each network connection, session management, data reordering and retransmission, data queuing and flow control, packet header generation, etc. off-loading these tasks from the

application processing engine or the network interface processing engine. The transport processing engine 1050 may also handle error checking, likewise freeing up the resources of other processing engines.

5 NETWORK INTERFACE / TRANSPORT SPLIT PROTOCOL

The embodiment of FIG. 1A contemplates that the protocol processing is shared between the transport processing engine 1050 and the network interface engine 1030. This sharing technique may be called "split protocol stack" processing. The division of tasks may be such that higher tasks in the protocol stack are assigned to the transport processor engine. For example, network interface engine 1030 may process all or some of the TCP/IP protocol stack as well as all protocols lower on the network protocol stack. Another approach could be to assign state modification intensive tasks to the transport processing engine.

In one embodiment related to a content delivery system that receives packets, the network interface engine performs the MAC header identification and verification, IP header identification and verification, IP header checksum validation, TCP and UDP header identification and validation, and TCP or UDP checksum validation. It also may perform the lookup to determine the TCP connection or UDP socket (protocol session identifier) to which a received packet belongs. Thus, the network interface engine verifies packet lengths, checksums, and validity. For transmission of packets, the network interface engine performs TCP or UDP checksum generation, IP header generation, and MAC header generation, IP checksum generation, MAC FCS/CRC generation, etc.

Tasks such as those described above can all be performed rapidly by the parallel and pipeline processors within a network processor. The "fly by" processing style of a network processor permits it to look at each byte of a packet as it passes through, using registers and other alternatives to memory access. The network processor's "stateless forwarding" operation is best suited for tasks not involving complex calculations that require rapid updating of state information.

30

An appropriate internal protocol may be provided for exchanging information between the network interface engine 1030 and the transport engine 1050 when setting up or terminating a TCP and/or UDP connections and to transfer packets between the two engines. For example, where the distributive interconnection medium is a switch fabric, the internal

protocol may be implemented as a set of messages exchanged across the switch fabric. These messages indicate the arrival of new inbound or outbound connections and contain inbound or outbound packets on existing connections, along with identifiers or tags for those connections. The internal protocol may also be used to transfer identifiers or tags between
5 the transport engine 1050 and the application processing engine 1070 and/or the storage processing engine 1040. These identifiers or tags may be used to reduce or strip or accelerate a portion of the protocol stack.

For example, with a TCP/IP connection, the network interface engine 1030 may
10 receive a request for a new connection. The header information associated with the initial request may be provided to the transport processing engine 1050 for processing. That result of this processing may be stored in the resources of the transport processing engine 1050 as state and management information for that particular network session. The transport processing engine 1050 then informs the network interface engine 1030 as to the location of
15 these results. Subsequent packets related to that connection that are processed by the network interface engine 1030 may have some of the header information stripped and replaced with an identifier or tag that is provided to the transport processing engine 1050. The identifier or tag may be a pointer, index or any other mechanism that provides for the identification of the location in the transport processing engine of the previously setup state and management
20 information (or the corresponding network session). In this manner, the transport processing engine 1050 does not have to process the header information of every packet of a connection. Rather, the transport interface engine merely receives a contextually meaningful identifier or tag that identifies the previous processing results for that connection.

25 In one embodiment, the data link, network, transport and session layers (layers 2-5) of a packet may be replaced by identifier or tag information. For packets related to an established connection the transport processing engine does not have to perform intensive processing with regard to these layers such as hashing, scanning, look up, etc. operations. Rather, these layers have already been converted (or processed) once in the transport
30 processing engine and the transport processing engine just receives the identifier or tag provided from the network interface engine that identifies the location of the conversion results.

In this manner an identifier label or tag is provided for each packet of an established connection so that the more complex data computations of converting header information may be replaced with a more simplistic analysis of an identifier or tag. The delivery of content is thereby accelerated, as the time for packet processing and the amount of system resources for packet processing are both reduced. The functionality of network processors, which provide efficient parallel processing of packet headers, is well suited for enabling the acceleration described herein. In addition, acceleration is further provided as the physical size of the packets provided across the distributed interconnect may be reduced.

10 Though described herein with reference to messaging between the network interface engine and the transport processing engine, the use of identifiers or tags may be utilized amongst all the engines in the modular pipelined processing described herein. Thus, one engine may replace packet or data information with contextually meaningful information that may require less processing by the next engine in the data and communication flow path. In addition, these techniques may be utilized for a wide variety of protocols and layers, not just the exemplary embodiments provided herein.

20 With the above-described tasks being performed by the network interface engine, the transport engine may perform TCP sequence number processing, acknowledgement and retransmission, segmentation and reassembly, and flow control tasks. These tasks generally call for storing and modifying connection state information on each TCP and UDP connection, and therefore are considered more appropriate for the processing capabilities of general purpose processors.

25 As will be discussed with references to alternative embodiments (such as FIGS. 2 and 2A), the transport engine 1050 and the network interface engine 1030 may be combined into a single engine. Such a combination may be advantageous as communication across the switch fabric is not necessary for protocol processing. However, limitations of many commercially available network processors make the split protocol stack processing described above desirable.

APPLICATION PROCESSING ENGINE

Application processing engine 1070 may be provided in content delivery system 1010 for application processing, and may be, for example, any hardware or hardware/software

subsystem suitable for session layer protocol processing (*e.g.*, HTTP, RTSP streaming, *etc.*) of content requests received from network transport processing engine 1050. In one embodiment application processing engine 1070 may be a dedicated application processing module based on an INTEL PENTIUM III processor running, for example, on standard x86 OS systems (*e.g.*, Linux, Windows NT, FreeBSD, *etc.*). Application processing engine 1070 may be utilized for dedicated application-only processing by virtue of the off-loading of all network protocol and storage processing elsewhere in content delivery system 1010. In one embodiment, processor programming for application processing engine 1070 may be generally similar to that of a conventional server, but without the tasks off-loaded to network interface processing engine 1030, storage processing engine 1040, and transport processing engine 1050.

STORAGE MANAGEMENT ENGINE

Storage management engine 1040 may be any hardware or hardware/software subsystem suitable for effecting delivery of requested content from content sources (for example content sources 1090 and/or 1100) in response to processed requests received from application processing engine 1070. It will also be understood that in various embodiments a storage management engine 1040 may be employed with content sources other than disk drives (*e.g.*, solid state storage, the storage systems described above, or any other media suitable for storage of data) and may be programmed to request and receive data from these other types of storage.

In one embodiment, processor programming for storage management engine 1040 may be optimized for data retrieval using techniques such as caching, and may include and maintain a disk cache to reduce the relatively long time often required to retrieve data from content sources, such as disk drives. Requests received by storage management engine 1040 from application processing engine 1070 may contain information on how requested data is to be formatted and its destination, with this information being comprehensible to transport processing engine 1050 and/or network interface processing engine 1030. The storage management engine 1040 may utilize a disk cache to reduce the relatively long time it may take to retrieve data stored in a storage medium such as disk drives. Upon receiving a request, storage management engine 1040 may be programmed to first determine whether the requested data is cached, and then to send a request for data to the appropriate content source 1090 or 1100. Such a request may be in the form of a conventional read request. The

designated content source 1090 or 1100 responds by sending the requested content to storage management engine 1040, which in turn sends the content to transport processing engine 1050 for forwarding to network interface processing engine 1030.

5 Based on the data contained in the request received from application processing engine 1070, storage processing engine 1040 sends the requested content in proper format with the proper destination data included. Direct communication between storage processing engine 1040 and transport processing engine 1050 enables application processing engine 1070 to be bypassed with the requested content. Storage processing engine 1040 may also be
10 configured to write data to content sources 1090 and/or 1100 (*e.g.*, for storage of live or broadcast streaming content).

In one embodiment storage management engine 1040 may be a dedicated block-level cache processor capable of block level cache processing in support of thousands of
15 concurrent multiple readers, and direct block data switching to network interface engine 1030. In this regard storage management engine 1040 may utilize a POWER PC 7450 processor in conjunction with ECC memory and a LSI SYMFC929 dual 2GBaud fibre channel controller for fibre channel interconnect to content sources 1090 and/or 1100 via dual
20 fibre channel arbitrated loop 1092. It will be recognized, however, that other forms of interconnection to storage sources suitable for retrieving content are also possible. Storage management engine 1040 may include hardware and/or software for running the Fibre Channel (FC) protocol, the SCSI (Small Computer Systems Interface) protocol, iSCSI protocol as well as other storage networking protocols.

25 Storage management engine 1040 may employ any suitable method for caching data, including simple computational caching algorithms such as random removal (RR), first-in first-out (FIFO), predictive read-ahead, over buffering, etc. algorithms. Other suitable caching algorithms include those that consider one or more factors in the manipulation of content stored within the cache memory, or which employ multi-level ordering, key based
30 ordering or function based calculation for replacement. In one embodiment, storage management engine may implement a layered multiple LRU (LMLRU) algorithm that uses an integrated block/buffer management structure including at least two layers of a configurable number of multiple LRU queues and a two-dimensional positioning algorithm for data blocks in the memory to reflect the relative priorities of a data block in the memory

in terms of both recency and frequency. Such a caching algorithm is described in further detail in U.S. patent application no. 09/797,198, entitled "Systems and Methods for Management of Memory" by Qiu et. al, the disclosure of which is incorporated herein by reference.

5

For increasing delivery efficiency of continuous content, such as streaming multimedia content, storage management engine 1040 may employ caching algorithms that consider the dynamic characteristics of continuous content. Suitable examples include, but are not limited to, interval caching algorithms. In one embodiment, improved caching performance of continuous content may be achieved using an LMLRU caching algorithm that weighs ongoing viewer cache value versus the dynamic time-size cost of maintaining particular content in cache memory. Such a caching algorithm is described in further detail in U.S. patent application no. 09/797,201, filed March 1, 2001 and entitled "Systems and Methods for Management of Memory in Information Delivery Environments" by Qiu et. al, the disclosure of which is incorporated herein by reference.

10
15

SYSTEM MANAGEMENT ENGINE

System management (or host) engine 1060 may be present to perform system management functions related to the operation of content delivery system 1010. Examples of system management functions include, but are not limited to, content provisioning/updates, comprehensive statistical data gathering and logging for sub-system engines, collection of shared user bandwidth utilization and content utilization data that may be input into billing and accounting systems, "on the fly" ad insertion into delivered content, customer programmable sub-system level quality of service ("QoS") parameters, remote management (e.g., SNMP, web-based, CLI), health monitoring, clustering controls, remote/local disaster recovery functions, predictive performance and capacity planning, etc. In one embodiment, content delivery bandwidth utilization by individual content suppliers or users (e.g., individual supplier/user usage of distributive interchange and/or content delivery engines) may be tracked and logged by system management engine 1060, enabling an operator of the content delivery system 1010 to charge each content supplier or user on the basis of content volume delivered.

20
25
30

System management engine 1060 may be any hardware or hardware/software subsystem suitable for performance of one or more such system management engines and in

one embodiment may be a dedicated application processing module based, for example, on an INTEL PENTIUM III processor running an x86 OS. Because system management engine 1060 is provided as a discrete modular engine, it may be employed to perform system management functions from within content delivery system 1010 without adversely affecting the performance of the system. Furthermore, the system management engine 1060 may maintain information on processing engine assignment and content delivery paths for various content delivery applications, substantially eliminating the need for an individual processing engine to have intimate knowledge of the hardware it intends to employ.

Under manual or scheduled direction by a user, system management processing engine 1060 may retrieve content from the network 1020 or from one or more external servers on a second network 1024 (e.g., LAN) using, for example, network file system (NFS) or common internet file system (CIFS) file sharing protocol. Once content is retrieved, the content delivery system may advantageously maintain an independent copy of the original content, and therefore is free to employ any file system structure that is beneficial, and need not understand low level disk formats of a large number of file systems.

Management interface 1062 may be provided for interconnecting system management engine 1060 with a network 1200 (e.g., LAN), or connecting content delivery system 1010 to other network appliances such as other content delivery systems 1010, servers, computers, etc. Management interface 1062 may be by any suitable network interface, such as 10/100 Ethernet, and may support communications such as management and origin traffic. Provision for one or more terminal management interfaces (not shown) for may also be provided, such as by RS-232 port, etc. The management interface may be utilized as a secure port to provide system management and control information to the content delivery system 1010. For example, tasks which may be accomplished through the management interface 1062 include reconfiguration of the allocation of system hardware (as discussed below with reference to FIGS. 1C-1F), programming the application processing engine, diagnostic testing, and any other management or control tasks. Though generally content is not envisioned being provided through the management interface, the identification of or location of files or systems containing content may be received through the management interface 1062 so that the content delivery system may access the content through the other higher bandwidth interfaces.

MANAGEMENT PERFORMED BY THE NETWORK INTERFACE

Some of the system management functionality may also be performed directly within the network interface processing engine 1030. In this case some system policies and filters may be executed by the network interface engine 1030 in real-time at wirespeed. These
5 polices and filters may manage some traffic / bandwidth management criteria and various service level guarantee policies. Examples of such system management functionality of are described below. It will be recognized that these functions may be performed by the system management engine 1060, the network interface engine 1030, or a combination thereof.

10 For example, a content delivery system may contain data for two web sites. An operator of the content delivery system may guarantee one web site ("the higher quality site") higher performance or bandwidth than the other web site ("the lower quality site"), presumably in exchange for increased compensation from the higher quality site. The network interface processing engine 1030 may be utilized to determine if the bandwidth
15 limits for the lower quality site have been exceeded and reject additional data requests related to the lower quality site. Alternatively, requests related to the lower quality site may be rejected to ensure the guaranteed performance of the higher quality site is achieved. In this manner the requests may be rejected immediately at the interface to the external network and additional resources of the content delivery system need not be utilized. In another example,
20 storage service providers may use the content delivery system to charge content providers based on system bandwidth of downloads (as opposed to the traditional storage area based fees). For billing purposes, the network interface engine may monitor the bandwidth use related to a content provider. The network interface engine may also reject additional requests related to content from a content provider whose bandwidth limits have been
25 exceeded. Again, in this manner the requests may be rejected immediately at the interface to the external network and additional resources of the content delivery system need not be utilized.

Additional system management functionality, such as quality of service (QoS)
30 functionality, also may be performed by the network interface engine. A request from the external network to the content delivery system may seek a specific file and also may contain Quality of Service (QoS) parameters. In one example, the QoS parameter may indicate the priority of service that a client on the external network is to receive. The network interface engine may recognize the QoS data and the data may then be utilized when managing the

data and communication flow through the content delivery system. The request may be transferred to the storage management engine to access this file via a read queue, e.g., [Destination IP][Filename][File Type (CoS)][Transport Priorities (QoS)]. All file read requests may be stored in a read queue. Based on CoS/QoS policy parameters as well as 5 buffer status within the storage management engine (empty, full, near empty, block seq#, etc), the storage management engine may prioritize which blocks of which files to access from the disk next, and transfer this data into the buffer memory location that has been assigned to be transmitted to a specific IP address. Thus based upon QoS data in the request provided to the content delivery system, the data and communication traffic through the 10 system may be prioritized. The QoS and other policy priorities may be applied to both incoming and outgoing traffic flow. Therefore a request having a higher QoS priority may be received after a lower order priority request, yet the higher priority request may be served data before the lower priority request.

15 The network interface engine may also be used to filter requests that are not supported by the content delivery system. For example, if a content delivery system is configured only to accept HTTP requests, then other requests such as FTP, telnet, etc. may be rejected or filtered. This filtering may be applied directly at the network interface engine, for example by programming a network processor with the appropriate system policies. Limiting 20 undesirable traffic directly at the network interface offloads such functions from the other processing modules and improves system performance by limiting the consumption of system resources by the undesirable traffic. It will be recognized that the filtering example described herein is merely exemplary and many other filter criteria or policies may be provided.

25 MULTI-PROCESSOR MODULE DESIGN

As illustrated in FIG. 1A, any given processing engine of content delivery system 1010 may be optionally provided with multiple processing modules so as to enable parallel or redundant processing of data and/or communications. For example, two or more individual dedicated TCP/UDP processing modules 1050a and 1050b may be provided for transport 30 processing engine 1050, two or more individual application processing modules 1070a and 1070b may be provided for network application processing engine 1070, two or more individual network interface processing modules 1030a and 1030b may be provided for network interface processing engine 1030 and two or more individual storage management processing modules 1040a and 1040b may be provided for storage management processing

engine 1040. Using such a configuration, a first content request may be processed between a first TCP/UDP processing module and a first application processing module via a first switch fabric path, at the same time a second content request is processed between a second TCP/UDP processing module and a second application processing module via a second switch fabric path. Such parallel processing capability may be employed to accelerate content delivery.

Alternatively, or in combination with parallel processing capability, a first TCP/UDP processing module 1050a may be backed-up by a second TCP/UDP processing module 1050b that acts as an automatic failover spare to the first module 1050a. In those embodiments employing multiple-port switch fabrics, various combinations of multiple modules may be selected for use as desired on an individual system-need basis (*e.g.*, as may be dictated by module failures and/or by anticipated or actual bottlenecks), limited only by the number of available ports in the fabric. This feature offers great flexibility in the operation of individual engines and discrete processing modules of a content delivery system, which may be translated into increased content delivery acceleration and reduction or substantial elimination of adverse effects resulting from system component failures.

In yet other embodiments, the processing modules may be specialized to specific applications, for example, for processing and delivering HTTP content, processing and delivering RTSP content, or other applications. For example, in such an embodiment an application processing module 1070a and storage processing module 1040a may be specially programmed for processing a first type of request received from a network. In the same system, application processing module 1070b and storage processing module 1040b may be specially programmed to handle a second type of request different from the first type. Routing of requests to the appropriate respective application and/or storage modules may be accomplished using a distributive interconnect and may be controlled by transport and/or interface processing modules as requests are received and processed by these modules using policies set by the system management engine.

30

Further, by employing processing modules capable of performing the function of more than one engine in a content delivery system, the assigned functionality of a given module may be changed on an as-needed basis, either manually or automatically by the system management engine upon the occurrence of given parameters or conditions. This

feature may be achieved, for example, by using similar hardware modules for different content delivery engines (*e.g.*, by employing PENTIUM III based processors for both network transport processing modules and for application processing modules), or by using different hardware modules capable of performing the same task as another module through software programmability (*e.g.*, by employing a POWER PC processor based module for storage management modules that are also capable of functioning as network transport modules). In this regard, a content delivery system may be configured so that such functionality reassignments may occur during system operation, at system boot-up or in both cases. Such reassignments may be effected, for example, using software so that in a given content delivery system every content delivery engine (or at a lower level, every discrete content delivery processing module) is potentially dynamically reconfigurable using software commands. Benefits of engine or module reassignment include maximizing use of hardware resources to deliver content while minimizing the need to add expensive hardware to a content delivery system.

15

Thus, the system disclosed herein allows various levels of load balancing to satisfy a work request. At a system hardware level, the functionality of the hardware may be assigned in a manner that optimizes the system performance for a given load. At the processing engine level, loads may be balanced between the multiple processing modules of a given processing engine to further optimize the system performance.

20

CLUSTERS OF SYSTEMS

The systems described herein may also be clustered together in groups of two or more to provide additional processing power, storage connections, bandwidth, etc. Communication between two individual systems each configured similar to content delivery system 1010 may be made through network interface 1022 and/or 1023. Thus, one content delivery system could communicate with another content delivery system through the network 1020 and/or 1024. For example, a storage unit in one content delivery system could send data to a network interface engine of another content delivery system. As an example, these communications could be via TCP/IP protocols. Alternatively, the distributed interconnects 1080 of two content delivery systems 1010 may communicate directly. For example, a connection may be made directly between two switch fabrics, each switch fabric being the distributed interconnect 1080 of separate content delivery systems 1010.

30

FIGS. 1G-1J illustrate four exemplary clusters of content delivery systems 1010. It will be recognized that many other cluster arrangements may be utilized including more or less content delivery systems. As shown in FIGS. 1G-1J, each content delivery system may be configured as described above and include a distributive interconnect 1080 and a network interface processing engine 1030. Interfaces 1022 may connect the systems to a network 1020. As shown in FIG. 1G, two content delivery systems may be coupled together through the interface 1023 that is connected to each system's network interface processing engine 1030. FIG. 1H shows three systems coupled together as in FIG. 1G. The interfaces 1023 of each system may be coupled directly together as shown, may be coupled together through a network or may be coupled through a distributed interconnect (for example a switch fabric).

FIG. 1I illustrates a cluster in which the distributed interconnects 1080 of two systems are directly coupled together through an interface 1500. Interface 1500 may be any communication connection, such as a copper connection, optical fiber, wireless connection, etc. Thus, the distributed interconnects of two or more systems may directly communicate without communication through the processor engines of the content delivery systems 1010. FIG. 1J illustrates the distributed interconnects of three systems directly communicating without first requiring communication through the processor engines of the content delivery systems 1010. As shown in FIG. 1J, the interfaces 1500 each communicate with each other through another distributed interconnect 1600. Distributed interconnect 1600 may be a switched fabric or any other distributed interconnect.

The clustering techniques described herein may also be implemented through the use of the management interface 1062. Thus, communication between multiple content delivery systems 1010 also may be achieved through the management interface 1062

EXEMPLARY DATA AND COMMUNICATION FLOW PATHS

FIG. 1B illustrates one exemplary data and communication flow path configuration among modules of one embodiment of content delivery system 1010. The flow paths shown in FIG. 1B are just one example given to illustrate the significant improvements in data processing capacity and content delivery acceleration that may be realized using multiple content delivery engines that are individually optimized for different layers of the software stack and that are distributively interconnected as disclosed herein. The illustrated embodiment of FIG. 1B employs two network application processing modules 1070a and

1070b, and two network transport processing modules 1050a and 1050b that are communicatively coupled with single storage management processing module 1040a and single network interface processing module 1030a. The storage management processing module 1040a is in turn coupled to content sources 1090 and 1100. In FIG. 1B, inter-processor command or control flow (i.e. incoming or received data request) is represented by dashed lines, and delivered content data flow is represented by solid lines. Command and data flow between modules may be accomplished through the distributive interconnection 1080 (not shown), for example a switch fabric.

10 As shown in FIG. 1B, a request for content is received and processed by network interface processing module 1030a and then passed on to either of network transport processing modules 1050a or 1050b for TCP/UDP processing, and then on to respective application processing modules 1070a or 1070b, depending on the transport processing module initially selected. After processing by the appropriate network application processing module, the request is passed on to storage management processor 1040a for processing and retrieval of the requested content from appropriate content sources 1090 and/or 1100. Storage management processing module 1040a then forwards the requested content directly to one of network transport processing modules 1050a or 1050b, utilizing the capability of distributive interconnection 1080 to bypass network application processing modules 1070a and 1070b. The requested content may then be transferred via the network interface processing module 1030a to the external network 1020. Benefits of bypassing the application processing modules with the delivered content include accelerated delivery of the requested content and offloading of workload from the application processing modules, each of which translate into greater processing efficiency and content delivery throughput. In this regard, throughput is generally measured in sustained data rates passed through the system and may be measured in bits per second. Capacity may be measured in terms of the number of files that may be partially cached, the number of TCP/IP connections per second as well as the number of concurrent TCP/IP connections that may be maintained or the number of simultaneous streams of a certain bit rate. In an alternative embodiment, the content may be delivered from the storage management processing module to the application processing module rather than bypassing the application processing module. This data flow may be advantageous if additional processing of the data is desired. For example, it may be desirable to decode or encode the data prior to delivery to the network.

To implement the desired command and content flow paths between multiple modules, each module may be provided with means for identification, such as a component ID. Components may be affiliated with content requests and content delivery to effect a desired module routing. The data-request generated by the network interface engine may include pertinent information such as the component ID of the various modules to be utilized in processing the request. For example, included in the data request sent to the storage management engine may be the component ID of the transport engine that is designated to receive the requested content data. When the storage management engine retrieves the data from the storage device and is ready to send the data to the next engine, the storage management engine knows which component ID to send the data to.

As further illustrated in FIG. 1B, the use of two network transport modules in conjunction with two network application processing modules provides two parallel processing paths for network transport and network application processing, allowing simultaneous processing of separate content requests and simultaneous delivery of separate content through the parallel processing paths, further increasing throughput/capacity and accelerating content delivery. Any two modules of a given engine may communicate with separate modules of another engine or may communicate with the same module of another engine. This is illustrated in FIG. 1B where the transport modules are shown to communicate with separate application modules and the application modules are shown to communicate with the same storage management module.

FIG. 1B illustrates only one exemplary embodiment of module and processing flow path configurations that may be employed using the disclosed method and system. Besides the embodiment illustrated in FIG. 1B, it will be understood that multiple modules may be additionally or alternatively employed for one or more other network content delivery engines (*e.g.*, storage management processing engine, network interface processing engine, system management processing engine, *etc.*) to create other additional or alternative parallel processing flow paths, and that any number of modules (*e.g.*, greater than two) may be employed for a given processing engine or set of processing engines so as to achieve more than two parallel processing flow paths. For example, in other possible embodiments, two or more different network transport processing engines may pass content requests to the same application unit, or vice-versa.

Thus, in addition to the processing flow paths illustrated in FIG. 1B, it will be understood that the disclosed distributive interconnection system may be employed to create other custom or optimized processing flow paths (e.g., by bypassing and/or interconnecting any given number of processing engines in desired sequence/s) to fit the requirements or desired operability of a given content delivery application. For example, the content flow path of FIG. 1B illustrates an exemplary application in which the content is contained in content sources 1090 and/or 1100 that are coupled to the storage processing engine 1040. However as discussed above with reference to FIG. 1A, remote and/or live broadcast content may be provided to the content delivery system from the networks 1020 and/or 1024 via the second network interface connection 1023. In such a situation the content may be received by the network interface engine 1030 over interface connection 1023 and immediately re-broadcast over interface connection 1022 to the network 1020. Alternatively, content may be proceed through the network interface connection 1023 to the network transport engine 1050 prior to returning to the network interface engine 1030 for re-broadcast over interface connection 1022 to the network 1020 or 1024. In yet another alternative, if the content requires some manner of application processing (for example encoded content that may need to be decoded), the content may proceed all the way to the application engine 1070 for processing. After application processing the content may then be delivered through the network transport engine 1050, network interface engine 1030 to the network 1020 or 1024.

20

In yet another embodiment, at least two network interface modules 1030a and 1030b may be provided, as illustrated in FIG. 1A. In this embodiment, a first network interface engine 1030a may receive incoming data from a network and pass the data directly to the second network interface engine 1030b for transport back out to the same or different network. For example, in the remote or live broadcast application described above, first network interface engine 1030a may receive content, and second network interface engine 1030b provide the content to the network 1020 to fulfill requests from one or more clients for this content. Peer-to-peer level communication between the two network interface engines allows first network interface engine 1030a to send the content directly to second network interface engine 1030b via distributive interconnect 1080. If necessary, the content may also be routed through transport processing engine 1050, or through transport processing engine 1050 and application processing engine 1070, in a manner described above.

30

Still yet other applications may exist in which the content required to be delivered is contained both in the attached content sources 1090 or 1100 and at other remote content sources. For example in a web caching application, not all content may be cached in the attached content sources, but rather some data may also be cached remotely. In such an application, the data and communication flow may be a combination of the various flows described above for content provided from the content sources 1090 and 1100 and for content provided from remote sources on the networks 1020 and/or 1024.

The content delivery system 1010 described above is configured in a peer-to-peer manner that allows the various engines and modules to communicate with each other directly as peers through the distributed interconnect. This is contrasted with a traditional server architecture in which there is a main CPU. Furthermore unlike the arbitrated bus of traditional servers, the distributed interconnect 1080 provides a switching means which is not arbitrated and allows multiple simultaneous communications between the various peers. The data and communication flow may by-pass unnecessary peers such as the return of data from the storage management processing engine 1040 directly to the network interface processing engine 1030 as described with reference to FIG. 1B.

Communications between the various processor engines may be made through the use of a standardized internal protocol. Thus, a standardized method is provided for routing through the switch fabric and communicating between any two of the processor engines which operate as peers in the peer to peer environment. The standardized internal protocol provides a mechanism upon which the external network protocols may "ride" upon or be incorporated within. In this manner additional internal protocol layers relating to internal communication and data exchange may be added to the external protocol layers. The additional internal layers may be provided in addition to the external layers or may replace some of the external protocol layers (for example as described above portions of the external headers may be replaced by identifiers or tags by the network interface engine).

The standardized internal protocol may consist of a system of message classes, or types, where the different classes can independently include fields or layers that are utilized to identify the destination processor engine or processor module for communication, control, or data messages provided to the switch fabric along with information pertinent to the corresponding message class. The standardized internal protocol may also include fields or

layers that identify the priority that a data packet has within the content delivery system. These priority levels may be set by each processing engine based upon system-wide policies. Thus, some traffic within the content delivery system may be prioritized over other traffic and this priority level may be directly indicated within the internal protocol call scheme
5 utilized to enable communications within the system. The prioritization helps enable the predictive traffic flow between engines and end-to-end through the system such that service level guarantees may be supported.

Other internally added fields or layers may include processor engine state, system
10 timestamps, specific message class identifiers for message routing across the switch fabric and at the receiving processor engine(s), system keys for secure control message exchange, flow control information to regulate control and data traffic flow and prevent congestion, and specific address tag fields that allow hardware at the receiving processor engines to move specific types of data directly into system memory.

15

In one embodiment, the internal protocol may be structured as a set, or system of messages with common system defined headers that allows all processor engines and, potentially, processor engine switch fabric attached hardware, to interpret and process messages efficiently and intelligently. This type of design allows each processing engine, and
20 specific functional entities within the processor engines, to have their own specific message classes optimized functionally for the exchanging their specific types control and data information. Some message classes that may be employed are: System Control messages for system management, Network Interface to Network Transport messages, Network Transport to Application Interface messages, File System to Storage engine messages, Storage engine to
25 Network Transport messages, etc. Some of the fields of the standardized message header may include message priority, message class, message class identifier (subtype), message size, message options and qualifier fields, message context identifiers or tags, etc. In addition, the system statistics gathering, management and control of the various engines may be performed across the switch fabric connected system using the messaging capabilities.

30

By providing a standardized internal protocol, overall system performance may be improved. In particular, communication speed between the processor engines across the switch fabric may be increased. Further, communications between any two processor engines may be enabled. The standardized protocol may also be utilized to reduce the processing

loads of a given engine by reducing the amount of data that may need to be processed by a given engine.

The internal protocol may also be optimized for a particular system application, providing further performance improvements. However, the standardized internal communication protocol may be general enough to support encapsulation of a wide range of networking and storage protocols. Further, while internal protocol may run on PCI, PCI-X, ATM, IB, Lightning I/O, the internal protocol is a protocol above these transport-level standards and is optimal for use in a switched (non-bus) environment such as a switch fabric. In addition, the internal protocol may be utilized to communicate devices (or peers) connected to the system in addition to those described herein. For example, a peer need not be a processing engine. In one example, a peer may be an ASIC protocol converter that is coupled to the distributed interconnect as a peer but operates as a slave device to other master devices within the system. The internal protocol may also be as a protocol communicated between systems such as used in the clusters described above.

Thus a system has been provided in which the networking / server clustering / storage networking has been collapsed into a single system utilizing a common low-overhead internal communication protocol / transport system.

20

CONTENT DELIVERY ACCELERATION

As described above, a wide range of techniques have been provided for accelerating content delivery from the content delivery system 1010 to a network. By accelerating the speed at which content may be delivered, a more cost effective and higher performance system may be provided. These techniques may be utilized separately or in various combinations.

25

One content acceleration technique involves the use of a multi-engine system with dedicated engines for varying processor tasks. Each engine can perform operations independently and in parallel with the other engines without the other engines needing to freeze or halt operations. The engines do not have to compete for resources such as memory, I/O, processor time, etc. but are provided with their own resources. Each engine may also be tailored in hardware and/or software to perform specific content delivery task, thereby providing increasing content delivery speeds while requiring less system resources. Further,

30

all data, regardless of the flow path, gets processed in a staged pipeline fashion such that each engine continues to process its layer of functionality after forwarding data to the next engine / layer.

5 Content acceleration is also obtained from the use of multiple processor modules within an engine. In this manner, parallelism may be achieved within a specific processing engine. Thus, multiple processors responding to different content requests may be operating in parallel within one engine.

10 Content acceleration is also provided by utilizing the multi-engine design in a peer to peer environment in which each engine may communicate as a peer. Thus, the communications and data paths may skip unnecessary engines. For example, data may be communicated directly from the storage processing engine to the transport processing engine without have to utilize resources of the application processing engine.

15 Acceleration of content delivery is also achieved by removing or stripping the contents of some protocol layers in one processing engine and replacing those layers with identifiers or tags for use with the next processor engine in the data or communications flow path. Thus, the processing burden placed on the subsequent engine may be reduced. In
20 addition, the packet size transmitted across the distributed interconnect may be reduced. Moreover, protocol processing may be off-loaded from the storage and/or application processors, thus freeing those resources to focus on storage or application processing.

 Content acceleration is also provided by using network processors in a network
25 endpoint system. Network processors generally are specialized to perform packet analysis functions at intermediate network nodes, but in the content delivery system disclosed the network processors have been adapted for endpoint functions. Furthermore, the parallel processor configurations within a network processor allow these endpoint functions to be performed efficiently.

30 In addition, content acceleration has been provided through the use of a distributed interconnection such as a switch fabric. A switch fabric allows for parallel communications between the various engines and helps to efficiently implement some of the acceleration techniques described herein.

It will be recognized that other aspects of the content delivery system 1010 also provide for accelerated delivery of content to a network connection. Further, it will be recognized that the techniques disclosed herein may be equally applicable to other network endpoint systems and even non-endpoint systems.

EXEMPLARY HARDWARE EMBODIMENTS

FIGS. 1C-1F illustrate just a few of the many multiple network content delivery engine configurations possible with one exemplary hardware embodiment of content delivery system 1010. In each illustrated configuration of this hardware embodiment, content delivery system 1010 includes processing modules that may be configured to operate as content delivery engines 1030, 1040, 1050, 1060, and 1070 communicatively coupled via distributive interconnection 1080. As shown in FIG. 1C, a single processor module may operate as the network interface processing engine 1030 and a single processor module may operate as the system management processing engine 1060. Four processor modules 1001 may be configured to operate as either the transport processing engine 1050 or the application processing engine 1070. Two processor modules 1003 may operate as either the storage processing engine 1040 or the transport processing engine 1050. The Gigabit (Gb) Ethernet front end interface 1022, system management interface 1062 and dual fibre channel arbitrated loop 1092 are also shown.

As mentioned above, the distributive interconnect 1080 may be a switch fabric based interconnect. As shown in FIG. 1C, the interconnect may be an IBM PRIZMA-E eight/sixteen port switch fabric 1081. In an eight port mode, this switch fabric is an 8 x 3.54 Gbps fabric and in a sixteen port mode, this switch fabric is a 16 x 1.77 Gbps fabric. The eight/sixteen port switch fabric may be utilized in an eight port mode for performance optimization. The switch fabric 1081 may be coupled to the individual processor modules through interface converter circuits 1082, such as IBM UDASL switch interface circuits. The interface converter circuits 1082 convert the data aligned serial link interface (DASL) to a UTOPIA (Universal Test and Operations PHY Interface for ATM) parallel interface. FPGAs (field programmable gate array) may be utilized in the processor modules as a fabric interface on the processor modules as shown in FIG. 1C. These fabric interfaces provide a 64/66Mhz PCI interface to the interface converter circuits 1082. FIG. 4 illustrates a functional block diagram of such a fabric interface 34. As explained below, the interface 34 provides an

interface between the processor module bus and the UDASL switch interface converter circuit 1082. As shown in FIG. 4, at the switch fabric side, a physical connection interface 41 provides connectivity at the physical level to the switch fabric. An example of interface 41 is a parallel bus interface complying with the UTOPIA standard. In the example of FIG. 4, interface 41 is a UTOPIA 3 interface providing a 32-bit 110 Mhz connection. However, the concepts disclosed herein are not protocol dependent and the switch fabric need not comply with any particular ATM or non ATM standard.

Still referring to FIG. 4, SAR (segmentation and reassembly) unit 42 has appropriate SAR logic 42a for performing segmentation and reassembly tasks for converting messages to fabric cells and vice-versa as well as message classification and message class-to-queue routing, using memory 42b and 42c for transmit and receive queues. This permits different classes of messages and permits the classes to have different priority. For example, control messages can be classified separately from data messages, and given a different priority. All fabric cells and the associated messages may be self routing, and no out of band signaling is required.

A special memory modification scheme permits one processor module to write directly into memory of another. This feature is facilitated by switch fabric interface 34 and in particular by its message classification capability. Commands and messages follow the same path through switch fabric interface 34, but can be differentiated from other control and data messages. In this manner, processes executing on processor modules can communicate directly using their own memory spaces.

Bus interface 43 permits switch fabric interface 34 to communicate with the processor of the processor module via the module device or I/O bus. An example of a suitable bus architecture is a PCI architecture, but other architectures could be used. Bus interface 43 is a master/target device, permitting interface 43 to write and be written to and providing appropriate bus control. The logic circuitry within interface 43 implements a state machine that provides the communications protocol, as well as logic for configuration and parity.

Referring again to FIG. 1C, network processor 1032 (for example a MOTOROLA C-Port C-5 network processor) of the network interface processing engine 1030 may be coupled directly to an interface converter circuit 1082 as shown. As mentioned above and further

shown in FIG. 1C, the network processor 1032 also may be coupled to the network 1020 by using a VITESSE GbE SERDES (serializer-deserializer) device (for example the VSC7123) and an SFP (small form factor pluggable) optical transceiver for LC fibre connection.

5 The processor modules 1003 include a fibre channel (FC) controller as mentioned above and further shown in FIG. 1C. For example, the fibre channel controller may be the LSI SYMFC929 dual 2GBaud fibre channel controller. The fibre channel controller enables communication with the fibre channel 1092 when the processor module 1003 is utilized as a storage processing engine 1040. Also illustrated in FIGS. 1C-1F is optional adjunct
10 processing unit 1300 that employs a POWER PC processor with SDRAM. The adjunct processing unit is shown coupled to network processor 1032 of network interface processing engine 1030 by a PCI interface. Adjunct processing unit 1300 may be employed for monitoring system parameters such as temperature, fan operation, system health, etc.

15 As shown in FIGS. 1C-1F, each processor module of content delivery engines 1030, 1040, 1050, 1060, and 1070 is provided with its own synchronous dynamic random access memory ("SDRAM") resources, enhancing the independent operating capabilities of each module. The memory resources may be operated as ECC (error correcting code) memory. Network interface processing engine 1030 is also provided with static random access memory
20 ("SRAM"). Additional memory circuits may also be utilized as will be recognized by those skilled in the art. For example, additional memory resources (such as synchronous SRAM and non-volatile FLASH and EEPROM) may be provided in conjunction with the fibre channel controllers. In addition, boot FLASH memory may also be provided on the of the processor modules.

25 The processor modules 1001 and 1003 of FIG. 1C may be configured in alternative manners to implement the content delivery processing engines such as the network interface processing engine 1030, storage processing engine 1040, transport processing engine 1050, system management processing engine 1060, and application processing engine 1070.
30 Exemplary configurations are shown in FIGS. 1D-1F, however, it will be recognized that other configurations may be utilized.

As shown in FIG. 1D, two Pentium III based processing modules may be utilized as network application processing modules 1070a and 1070b of network application processing

engine 1070. The remaining two Pentium III-based processing modules are shown in FIG. 1D configured as network transport / protocol processing modules 1050a and 1050b of network transport / protocol processing engine 1050. The embodiment of FIG. 1D also includes two POWER PC-based processor modules, configured as storage management
5 processing modules 1040a and 1040b of storage management processing engine 1040. A single MOTOROLA C-Port C-5 based network processor is shown employed as network interface processing engine 1030, and a single Pentium III-based processing module is shown employed as system management processing engine 1060.

10 In FIG. 1E, the same hardware embodiment of FIG. 1C is shown alternatively configured so that three Pentium III-based processing modules function as network application processing modules 1070a, 1070b and 1070c of network application processing engine 1070, and so that the sole remaining Pentium III-based processing module is configured as a network transport processing module 1050a of network transport processing
15 engine 1050. As shown, the remaining processing modules are configured as in FIG. 1D.

In FIG. 1F, the same hardware embodiment of FIG. 1C is shown in yet another alternate configuration so that three Pentium III-based processing modules function as application processing modules 1070a, 1070b and 1070c of network application processing
20 engine 1070. In addition, the network transport processing engine 1050 includes one Pentium III-based processing module that is configured as network transport processing module 1050a, and one POWER PC-based processing module that is configured as network transport processing module 1050b. The remaining POWER PC-based processor module is configured as storage management processing module 1040a of storage management
25 processing engine 1040.

It will be understood with benefit of this disclosure that the hardware embodiment and multiple engine configurations thereof illustrated in FIGS. 1C-1F are exemplary only, and that other hardware embodiments and engine configurations thereof are also possible. It will
30 further be understood that in addition to changing the assignments of individual processing modules to particular processing engines, distributive interconnect 1080 enables the various processing flow paths between individual modules employed in a particular engine configuration in a manner as described in relation to FIG. 1B. Thus, for any given hardware embodiment and processing engine configuration, a number of different processing flow

paths may be employed so as to optimize system performance to suit the needs of particular system applications.

SINGLE CHASSIS DESIGN

5 As mentioned above, the content delivery system 1010 may be implemented within a single chassis, such as for example, a 2U chassis. The system may be expanded further while still remaining a single chassis system. In particular, utilizing a multiple processor module or blade arrangement connected through a distributive interconnect (for example a switch fabric) provides a system that is easily scalable. The chassis and interconnect may be
10 configured with expansion slots provided for adding additional processor modules. Additional processor modules may be provided to implement additional applications within the same chassis. Alternatively, additional processor modules may be provided to scale the bandwidth of the network connection. Thus, though describe with respect to a 1Gbps Ethernet connection to the external network, a 10 Gbps, 40 Gbps or more connection may be
15 established by the system through the use of more network interface modules. Further, additional processor modules may be added to address a system's particular bottlenecks without having to expand all engines of the system. The additional modules may be added during a systems initial configuration, as an upgrade during system maintenance or even hot plugged during system operation.

20

ALTERNATIVE SYSTEMS CONFIGURATIONS

Further, the network endpoint system techniques disclosed herein may be implemented in a variety of alternative configurations that incorporate some, but not necessarily all, of the concepts disclosed herein. For example, FIGS. 2 and 2A disclose two
25 exemplary alternative configurations. It will be recognized, however, that many other alternative configurations may be utilized while still gaining the benefits of the inventions disclosed herein.

FIG. 2 is a more generalized and functional representation of a content delivery
30 system showing how such a system may be alternately configured to have one or more of the features of the content delivery system embodiments illustrated in FIGS. 1A-1F. FIG. 2 shows content delivery system 200 coupled to network 260 from which content requests are received and to which content is delivered. Content sources 265 are shown coupled to content delivery system 200 via a content delivery flow path 263 that may be, for example, a

storage area network that links multiple content sources 265. A flow path 203 may be provided to network connection 272, for example, to couple content delivery system 200 with other network appliances, in this case one or more servers 201 as illustrated in FIG. 2.

5 In FIG. 2 content delivery system 200 is configured with multiple processing and memory modules that are distributively interconnected by inter-process communications path 230 and inter-process data movement path 235. Inter-process communications path 230 is provided for receiving and distributing inter-processor command communications between the modules and network 260, and interprocess data movement path 235 is provided for
10 receiving and distributing inter-processor data among the separate modules. As illustrated in FIGS. 1A-1F, the functions of inter-process communications path 230 and inter-process data movement path 235 may be together handled by a single distributive interconnect 1080 (such as a switch fabric, for example), however, it is also possible to separate the communications and data paths as illustrated in FIG. 2, for example using other interconnect technology.

15

FIG. 2 illustrates a single networking subsystem processor module 205 that is provided to perform the combined functions of network interface processing engine 1030 and transport processing engine 1050 of FIG. 1A. Communication and content delivery between network 260 and networking subsystem processor module 205 are made through network
20 connection 270. For certain applications, the functions of network interface processing engine 1030 and transport processing engine 1050 of FIG. 1A may be so combined into a single module 205 of FIG. 2 in order to reduce the level of communication and data traffic handled by communications path 230 and data movement path 235 (or single switch fabric), without adversely impacting the resources of application processing engine or subsystem
25 module. If such a modification were made to the system of FIG. 1A, content requests may be passed directly from the combined interface/transport engine to network application processing engine 1070 via distributive interconnect 1080. Thus, as previously described the functions of two or more separate content delivery system engines may be combined as desired (*e.g.*, in a single module or in multiple modules of a single processing blade), for
30 example, to achieve advantages in efficiency or cost.

In the embodiment of FIG. 2, the function of network application processing engine 1070 of FIG. 1A is performed by application processing subsystem module 225 of FIG. 2 in conjunction with application RAM subsystem module 220 of FIG. 2. System monitor

module 240 communicates with server/s 201 through flow path 203 and Gb Ethernet network interface connection 272 as also shown in FIG. 2. The system monitor module 240 may provide the function of the system management engine 1060 of FIG. 1A and/or other system policy / filter functions such as may also be implemented in the network interface processing engine 1030 as described above with reference to FIG. 1A.

Similarly, the function of network storage management engine 1040 is performed by storage subsystem module 210 in conjunction with file system cache subsystem module 215. Communication and content delivery between content sources 265 and storage subsystem module 210 are shown made directly through content delivery flowpath 263 through fibre channel interface connection 212. Shared resources subsystem module 255 is shown provided for access by each of the other subsystem modules and may include, for example, additional processing resources, additional memory resources such as RAM, *etc.*

Additional processing engine capability (*e.g.*, additional system management processing capability, additional application processing capability, additional storage processing capability, encryption / decryption processing capability, compression / decompression processing capability, encoding / decoding capability, other processing capability, *etc.*) may be provided as desired and is represented by other subsystem module 275. Thus, as previously described the functions of a single network processing engine may be sub-divided between separate modules that are distributively interconnected. The subdivision of network processing engine tasks may also be made for reasons of efficiency or cost, and/or may be taken advantage of to allow resources (*e.g.*, memory or processing) to be shared among separate modules. Further, additional shared resources may be made available to one or more separate modules as desired.

Also illustrated in FIG. 2 are optional monitoring agents 245 and resources 250. In the embodiment of FIG. 2, each monitoring agent 245 may be provided to monitor the resources 250 of its respective processing subsystem module, and may track utilization of these resources both within the overall system 200 and within its respective processing subsystem module. Examples of resources that may be so monitored and tracked include, but are not limited to, processing engine bandwidth, Fibre Channel bandwidth, number of available drives, IOPS (input/output operations per second) per drive and RAID (redundant array of inexpensive discs) levels of storage devices, memory available for caching blocks of

data, table lookup engine bandwidth, availability of RAM for connection control structures and outbound network bandwidth availability, shared resources (such as RAM) used by streaming application on a per-stream basis as well as for use with connection control structures and buffers, bandwidth available for message passing between subsystems,
5 bandwidth available for passing data between the various subsystems, *etc.*

Information gathered by monitoring agents 245 may be employed for a wide variety of purposes including for billing of individual content suppliers and/or users for pro-rata use of one or more resources, resource use analysis and optimization, resource health alarms, *etc.*
10 In addition, monitoring agents may be employed to enable the deterministic delivery of content by system 200 as described further herein.

In operation, content delivery system 200 of FIG. 2 may be configured to wait for a request for content or services prior to initiating content delivery or performing a service. A
15 request for content, such as a request for access to data, may include, for example, a request to start a video stream, a request for stored data, *etc.* A request for services may include, for example, a request for to run an application, to store a file, *etc.* A request for content or services may be received from a variety of sources. For example, if content delivery system 200 is employed as a stream server, a request for content may be received from a client
20 system attached to a computer network or communication network such as the Internet. In a larger system environment, e.g., a data center, a request for content or services may be received from a separate subcomponent or a system management processing engine, that is responsible for performance of the overall system or from a sub-component that is unable to process the current request. Similarly, a request for content or services may be received by a
25 variety of components of the receiving system. For example, if the receiving system is a stream server, networking subsystem processor module 205 might receive a content request. Alternatively, if the receiving system is a component of a larger system, e.g., a data center, system management processing engine may be employed to receive the request.

30 Upon receipt of a request for content or services, the request may be filtered by system monitor 240. Such filtering may serve as a screening agent to filter out requests that the receiving system is not capable of processing (*e.g.*, requests for file writes from read-only system embodiments, unsupported protocols, content/services unavailable on system 200, *etc.*). Such requests may be rejected outright and the requestor notified, may be re-directed to

a server 201 or other content delivery system 200 capable of handling the request, or may be disposed of any other desired manner.

Referring now in more detail to one embodiment of FIG. 2 as may be employed in a stream server configuration, networking processing subsystem module 205 may include the hardware and/or software used to run TCP/IP (Transmission Control Protocol/Internet Protocol), UDP/IP (User Datagram Protocol/Internet Protocol), RTP (Real-Time Transport Protocol), Internet Protocol (IP), Wireless Application Protocol (WAP) as well as other networking protocols. Network interface connections 270 and 272 may be considered part of networking subsystem processing module 205 or as separate components. Storage subsystem module 210 may include hardware and/or software for running the Fibre Channel (FC) protocol, the SCSI (Small Computer Systems Interface) protocol, iSCSI protocol as well as other storage networking protocols. FC interface 212 to content delivery flowpath 263 may be considered part of storage subsystem module 210 or as a separate component. File system cache subsystem module 215 may include, in addition to cache hardware, one or more cache management algorithms as well as other software routines.

Application RAM subsystem module 220 may function as a memory allocation subsystem and application processing subsystem module 225 may function as a stream-serving application processor bandwidth subsystem. Among other services, application RAM subsystem module 220 and application processing subsystem module 225 may be used to facilitate such services as the pulling of content from storage and/or cache, the formatting of content into RTSP (Real-Time Streaming Protocol) or another streaming protocol as well the passing of the formatted content to networking subsystem 205.

25

As previously described, system monitor module 240 may be included in content delivery system 200 to manage one or more of the subsystem processing modules, and may also be used to facilitate communication between the modules.

In part to allow communications between the various subsystem modules of content delivery system 200, inter-process communication path 230 may be included in content delivery system 200, and may be provided with its own monitoring agent 245. Inter-process communications path 230 may be a reliable protocol path employing a reliable IPC (Inter-process Communications) protocol. To allow data or information to be passed between the

30

various subsystem modules of content delivery system 200, inter-process data movement path 235 may also be included in content delivery system 200, and may be provided with its own monitoring agent 245. As previously described, the functions of inter-process communications path 230 and inter-process data movement path 235 may be together
5 handled by a single distributive interconnect 1080, that may be a switch fabric configured to support the bandwidth of content being served.

In one embodiment, access to content source 265 may be provided via a content delivery flow path 263 that is a fibre channel storage area network (SAN), a switched
10 technology. In addition, network connectivity may be provided at network connection 270 (e.g., to a front end network) and/or at network connection 272 (e.g., to a back end network) via switched gigabit Ethernet in conjunction with the switch fabric internal communication system of content delivery system 200. As such, that the architecture illustrated in FIGURE 2 may be generally characterized as equivalent to a networking system.

15

One or more shared resources subsystem modules 255 may also be included in a stream server embodiment of content delivery system 200, for sharing by one or more of the other subsystem modules. Shared resources subsystem module 255 may be monitored by the monitoring agents 245 of each subsystem sharing the resources. The monitoring agents 245
20 of each subsystem module may also be capable of tracking usage of shared resources 255. As previously described, shared resources may include RAM (Random Access Memory) as well as other types of shared resources.

Each monitoring agent 245 may be present to monitor one or more of the resources
25 250 of its subsystem processing module as well as the utilization of those resources both within the overall system and within the respective subsystem processing module. For example, monitoring agent 245 of storage subsystem module 210 may be configured to monitor and track usage of such resources as processing engine bandwidth, Fibre Channel bandwidth to content delivery flow path 263, number of storage drives attached, number of
30 input/output operations per second (IOPS) per drive and RAID levels of storage devices that may be employed as content sources 265. Monitoring agent 245 of file system cache subsystem module 215 may be employed monitor and track usage of such resources as processing engine bandwidth and memory employed for caching blocks of data. Monitoring agent 245 of networking subsystem processing module 205 may be employed to monitor and

track usage of such resources as processing engine bandwidth, table lookup engine bandwidth, RAM employed for connection control structures and outbound network bandwidth availability. Monitoring agent 245 of application processing subsystem module 225 may be employed to monitor and track usage of processing engine bandwidth.

5 Monitoring agent 245 of application RAM subsystem module 220 may be employed to monitor and track usage of shared resource 255, such as RAM, which may be employed by a streaming application on a per-stream basis as well as for use with connection control structures and buffers. Monitoring agent 245 of inter-process communication path 230 may be employed to monitor and track usage of such resources as the bandwidth used for message

10 passing between subsystems while monitoring agent 245 of inter-process data movement path 235 may be employed to monitor and track usage of bandwidth employed for passing data between the various subsystem modules.

The discussion concerning FIG. 2 above has generally been oriented towards a system

15 designed to deliver streaming content to a network such as the Internet using, for example, Real Networks, Quick Time or Microsoft Windows Media streaming formats. However, the disclosed systems and methods may be deployed in any other type of system operable to deliver content, for example, in web serving or file serving system environments. In such environments, the principles may generally remain the same. However for application

20 processing embodiments, some differences may exist in the protocols used to communicate and the method by which data delivery is metered (via streaming protocol, versus TCP/IP windowing).

FIG. 2A illustrates an even more generalized network endpoint computing system that

25 may incorporate at least some of the concepts disclosed herein. As shown in Figure 2A, a network endpoint system 10 may be coupled to an external network 11. The external network 11 may include a network switch or router coupled to the front end of the endpoint system 10. The endpoint system 10 may be alternatively coupled to some other intermediate network node of the external network. The system 10 may further include a network engine

30 9 coupled to an interconnect medium 14. The network engine 9 may include one or more network processors. The interconnect medium 14 may be coupled to a plurality of processor units 13 through interfaces 13a. Each processor unit 13 may optionally be couple to data storage (in the exemplary embodiment shown each unit is couple to data storage). More or less processor units 13 may be utilized than shown in FIG. 2A.

The network engine 9 may be a processor engine that performs all protocol stack processing in a single processor module or alternatively may be two processor modules (such as the network interface engine 1030 and transport engine 1050 described above) in which
5 split protocol stack processing techniques are utilized. Thus, the functionality and benefits of the content delivery system 1010 described above may be obtained with the system 10. The interconnect medium 14 may be a distributive interconnection (for example a switch fabric) as described with reference to FIG. 1A. All of the various computing, processing, communication, and control techniques described above with reference to FIGS. 1A-1F and 2
10 may be implemented within the system 10. It will therefore be recognized that these techniques may be utilized with a wide variety of hardware and computing systems and the techniques are not limited to the particular embodiments disclosed herein.

The system 10 may consist of a variety of hardware configurations. In one
15 configuration the network engine 9 may be a stand-alone device and each processing unit 13 may be a separate server. In another configuration the network engine 9 may be configured within the same chassis as the processing units 13 and each processing unit 13 may be a separate server card or other computing system. Thus, a network engine (for example an engine containing a network processor) may provide transport acceleration and be combined
20 with multi-server functionality within the system 10. The system 10 may also include shared management and interface components. Alternatively, each processing unit 13 may be a processing engine such as the transport processing engine, application engine, storage engine, or system management engine of FIG. 1A. In yet another alternative, each processing unit
25 may be a processor module (or processing blade) of the processor engines shown in the system of FIG. 1A.

FIG. 2B illustrates yet another use of a network engine 9. As shown in FIG. 2B, a network engine 9 may be added to a network interface card 35. The network interface card 35 may further include the interconnect medium 14 which may be similar to the distributed
30 interconnect 1080 described above. The network interface card may be part of a larger computing system such as a server. The network interface card may couple to the larger system through the interconnect medium 14. In addition to the functions described above, the network engine 9 may perform all traditional functions of a network interface card.

It will be recognized that all the systems described above (FIGS. 1A, 2, 2A, and 2B) utilize a network engine between the external network and the other processor units that are appropriate for the function of the particular network node. The network engine may therefore offload tasks from the other processors. The network engine also may perform
5 “look ahead processing” by performing processing on a request before the request reaches whatever processor is to perform whatever processing is appropriate for the network node. In this manner, the system operations may be accelerated and resources utilized more efficiently.

10 DETERMINISTIC INFORMATION MANAGEMENT

In certain embodiments, the disclosed methods and systems may be advantageously employed for the deterministic management of information (*e.g.*, content, data, services, commands, communications, *etc.*) at any level (*e.g.*, file level, bit level, *etc.*). Examples include those described in U.S. Patent application Serial No. 09/797,200, filed March 1, 2001
15 and entitled “Systems And Methods For The Deterministic Management of Information,” by Johnson et al., the disclosure of which is incorporated herein by reference.

As used herein, “deterministic information management” includes the manipulation of information (*e.g.*, delivery, routing or re-routing, serving, storage, caching, processing, *etc.*)
20 in a manner that is based at least partially on the condition or value of one or more system or subsystem parameters. Examples of such parameters will be discussed further below and include, but are not limited to, system or subsystem resources such as available storage access, available application memory, available processor capacity, available network bandwidth, *etc.* Such parameters may be utilized in a number of ways to deterministically
25 manage information. For example, requests for information delivery may be rejected or queued based on availability of necessary system or subsystem resources, and/or necessary resources may be allocated or reserved in advance of handling a particular information request, *e.g.*, as part of an end-to-end resource reservation scheme. Managing information in a deterministic manner offers a number of advantages over traditional information
30 management schemes, including increased hardware utilization efficiency, accelerated information throughput, and greater information handling predictability. Features of deterministic information management may also be employed to enhance capacity planning and to manage growth more easily.

Deterministic information management may be implemented in conjunction with any system or subsystem environment that is suitable for the manipulation of information, including network endpoint systems, intermediate node systems and endpoint/intermediate hybrid systems discussed elsewhere herein. Specific examples of such systems include, but
5 are not limited to, storage networks, servers, switches, routers, web cache systems, *etc.* It will be understood that any of the information delivery system embodiments described elsewhere herein, including those described in relation to FIGS. 1A and 2, may be employed to manage information in a deterministic manner.

10 FIG. 5 is a flow diagram illustrating one embodiment of a method 100 for deterministic delivery of content in response to a request for the same. Although FIG. 5 is described in relation to content delivery, it will be understood with benefit of this disclosure that the deterministic methods and systems described herein may be used in a wide variety of information management scenarios, including application serving, and are therefore not
15 limited to only processing requests for content. It will also be understood that the types of content that may be deterministically managed or delivered include any types of content described elsewhere herein, *e.g.*, static content, dynamic content, *etc.*

With regard to deterministic content delivery methods such as that illustrated in FIG.
20 5, it will be understood that different types of content may be deterministically managed in different ways to achieved optimum efficiency. For example, when employed to deliver streaming content, such as video or audio streams, the disclosed methods may be advantageously employed to provide increased stability and predictability in stream delivery by, among other things, predicting the capacity of a content delivery system to deliver many
25 long-lived streams. Each such stream requires a certain amount of resources, which may be identified at the time the stream is opened. For web page delivery, such as HTTP serving, requests may be handled as aggregates.

When employed with an information management system such as the content delivery
30 system embodiment illustrated in FIG. 2, method 100 of FIG. 5 may be used to allow a system monitor, a plurality of subsystems and one or more shared resources of a system to effectively interact and provide deterministic delivery of data and services. However, it will be understood that method 100 may be implemented with a variety of other information management system configurations to allow deterministic interaction between system

components, for example, between the multiple content delivery engines described in relation to FIG. 1A. Furthermore, FIG. 5 represents just one exemplary set of method steps that may be employed to implement deterministic interaction between system components, with it being understood that any other number, type and/or sequence of method steps suitable for enabling deterministic interaction between two or more components of an information management system may be employed. Selection of suitable steps may be made based on a variety of individual system characteristics, for example, system hardware, system function and environment, system cost and capabilities, *etc.*

Method 100 of FIG. 5 generally begins at step 105 where a request for content, is awaited. A request for content, as is the case with a request for other information (*e.g.*, data, services, *etc.*), may be received from a variety of sources. For example, if the system is employed in a stream server environment, the request for content may be received from a client system attached to a computer network or communication network such as the Internet, or any of the other sources of requests described elsewhere herein, including from an overloaded subcomponent of the system which is presently unable to process the current request for content.

Upon receipt of a request for content at step 105, the request for content may be filtered at step 110 by, for example, one or more processing engines or modules that perform the function of a system monitor. Filtering the request for content may serve a variety of purposes. For example, the filtering performed at step 110 may serve as a screening agent to reject requests for content that the receiving system is not capable of processing. Step 110 may also be employed as a first parsing of the received requests for content such that a subsequent level of filtering is employed to further direct the work or requests for content to an appropriate subsystem or system area for processing. It will be understood that other filtering techniques and purposes may also be employed in conjunction with the disclosed systems and methods.

Once the request for content has been filtered, method 100 proceeds to step 115 where the filtered request for content is evaluated. Evaluation of the request for content may be performed by, for example, a system monitor or another subsystem or combination of subsystems capable of evaluating a request for content. With regard to step 115, a request for content may be evaluated in a number of different ways in relation to one or more system or

subsystem parameters. For example, a request for content may be evaluated in relation to the requirements for fulfilling the request, *e.g.*, the identified resources that are going to be required to process the particular request for content. As an illustration, a request for access to a streaming video file may be evaluated in relation to one or more of the following requirements: a need for access to storage, a need for processor usage, a need for network bandwidth to enable the data to be streamed from storage, as well as a need for other resources. Evaluation of a request in this manner may be used to enable a system monitor to determine the availability of the required resources, by first identifying what resources will be required to process the request for content. Additional details regarding evaluation of a request for content will be discussed below.

After the resources required to process the current request for content have been identified at step 115, method 100 proceeds to step 120. At step 120, the required resources identified in step 115 may be polled to determine whether the current workload of the required resources is such that the required resources will be available to process the current request for content upon its acceptance. Available resources may be defined, for example, as those required resources that are immediately available to process a request for content, or those resources that will be available within a predefined amount of time. Polling of each of the required resources may occur in parallel or serial manner.

Using the embodiment of FIG. 2 to illustrate, a system operable to process a request for content may include a system monitor 240, a plurality of subsystems (*e.g.*, 210, 215, *etc.*) and one or more shared resources 255. Each subsystem may include one or more resources 250 that enable that subsystem to perform its respective tasks, and a monitoring agent 245 that is configured to monitor, control, reserve and otherwise manage those resources. In this embodiment, the polling at step 120 may involve the system monitor 240 communicating its resource needs to the monitoring agent 245 of the subsystem having the required resources to process the current request for content. Upon receipt of such communication, the monitoring agent 245 evaluates the workload of the resources 250 for which it is responsible to determine whether there is or there will be enough available resources to process the request for content under consideration.

For example, if the system monitor 240 has indicated that it needs four 4 (four) MB (megabytes) of memory from an application RAM (Random Access Memory) subsystem and

the monitoring agent 245 of the application RAM subsystem 220 determines that only 1 MB of memory is available, the system monitor 240 will be notified by the monitoring agent 245 of the unavailability of the application RAM subsystem 220. As a result of the polling of the required resources, a response indicative of the availability of the required resources may be generated by the monitoring agent 245, and transferred to the polling unit, i.e., the system monitor 240. It will be understood that similar interaction between system monitor 240 and respective monitoring agents 245 of other subsystems may occur as appropriate for a given system configuration and a given information request.

10 In an alternate embodiment, instead of polling the subsystems, a system monitor may receive notifications generated by and transmitted from one or more of the various subsystems. Such notifications may be indicative of the availability of the resources of the various subsystems. For example, if RAM subsystem 220 of FIG. 2 has no available memory, RAM subsystem 220 may automatically notify the system monitor 240 that it is out of
15 memory and therefore unable to take on additional requests for processing. When RAM subsystem resources become or are becoming available, RAM subsystem 220 may automatically generate and transmit a notification to the system monitor 240 indicative of the fact that the RAM subsystem is now or is becoming available to take on additional requests for processing.

20

Using the above-described automatic notification scheme, a given subsystem may inform a system monitor that the subsystem has reached a threshold of utilization and that the system monitor should slow down on accepting requests. Once a subsystem frees up some of its resources, the given subsystem may then notify the system monitor that it is available or is
25 becoming available and that the system monitor may resume normal operation. Such an implementation allows the system monitor to maintain an awareness of the availability of the subsystems and their resources without requiring the system monitor to poll the subsystems, although it will be understood that both polling and notification functions may be employed together in a given system embodiment. Thus, it will be understood that the various methods
30 and systems disclosed herein may be implemented in various ways to accomplish communication of the status of subsystem resource availability in any manner suitable for accomplishing the deterministic management of information disclosed herein.

At step 125 of method 100, the system monitor accumulates the responses to the resource polls or resource notifications for later evaluation. In one embodiment of method 100, optional step 130 may also be included. At step 130, method 100 loops until all responses or notifications have been received from concerning the identified required
5 resources before allowing method 100 to proceed to step 135.

At step 135, the responses to the resource polls or resource notifications are evaluated, for example, by a system monitor. Evaluation of the resource responses or notifications may involve evaluation of any one or more desired characteristics of the resources including, but
10 not limited to, current availability or estimated time until availability of adequate resources, capability of available resources in relation to a particular request, *etc.* In one embodiment, evaluation may involve determining whether adequate resources are available, or will be available within a specific time, to process the request for content under consideration. For example, method 100 may require that all of the resources required to process a request for
15 content be immediately available, prior to proceeding toward acceptance of a content request.

Alternatively, evaluation of the responses from the polled resources may entail ensuring that a defined minimum portion of the required resources are immediately available or will become available in a specified amount of time. Such a specified amount of time may
20 be defined on a system-level basis, automatically set by policy on a system-level basis, and/or automatically set by policy on a request-by-request basis. For example, a policy may be implemented to set a maximum allowable time frame for delivery of content based on one or more parameters including, but not limited to, type of request, type of file or service requested, origin of request, identification of the requesting user, priority information (*e.g.*,
25 QoS, Service Level Agreement (“SLA”), *etc.*) associated with a particular request, *etc.* A specified maximum allowable time frame may also be set by policy on a system level basis based on one or more parameters including, but not limited to, workload of the present system, resource availability or workload of other linked systems, *etc.* It will be understood that other guidelines or definitions for acceptable resource availability may be employed.

30

If, at step 135, the required resources are determined to be available within the guidelines specified for method 100 by one or more system policies, method 100 may proceed to step 140. At step 140, the resources required to process the request for content under consideration may be reserved. For example, using FIG. 2 as an illustration again,

reservation of identified required resources 250 may be accomplished by the system monitor 240 or, alternatively, by a combination of the system monitor 240 and the appropriate monitoring agents 245 responsible for each of the identified required resources 250. In one embodiment, reservation of resources includes setting aside that portion of the available
5 resources, or of the resources that will become available within a given time, that has been determined to be required to process the request for content, *e.g.*, a block of memory, a portion of processor power, a portion of network and storage access bandwidth, etc. Reservation of the required resources may be employed to ensure that the current request for content will be readily processed.

10

Once the required resources have been reserved at step 140, method 100 proceeds to step 145. At step 145, the request for content may be queued for processing by the reserved resources. Upon queuing the request for content at step 145, method 100 returns to step 105 where receipt of a subsequent request for content is awaited by the system.

15

If, at step 135, it is determined that the required resources are not available to process the request for content, method 100 may proceed to step 150. At step 150, one or more handling policies may be evaluated to determine the proper disposition of the request for content. In this regard, a variety of handling policies (*e.g.*, steps 155, 160 and 165 of FIG. 5)
20 may be made available to properly dispose of requests for content for which the identified resources required to process a request are not available. A given handling policy may be implemented according to one or more system or subsystem parameters in any manner appropriate for the given system environment.

25

Examples of possible parameters that may be evaluated at step 150 to determine the appropriate handling policy for a given request include, but are not limited to, resource availability and capability of other content delivery systems (*e.g.*, one or more other clustered systems), capability and/or anticipated time until availability of resources in the present content delivery system, the source of the request, the request priority (*e.g.*, SLA, QoS bit
30 set), *etc.*

In one exemplary embodiment, it is possible at step 150 to select a given policy (*e.g.*, 155, 160 or 165) on a request-by-request or user-by-user basis, for example, based on a specified maximum allowable content delivery time frame that may vary for each request

according to one or more parameters such as type of request, type of file or service requested, origin of request, identification of the requesting user, priority information (*e.g.*, QoS, Service Level Agreement (“SLA”), *etc.*) associated with a particular request, *etc.* For example, requests from different users and/or requests having different priority codes may be individually associated with different maximum time frame values for delivery of content. When it is determined at step 135 that system resources for the current system won’t be available for a given period of time, this given period of time may be compared with the maximum allowable content delivery time frame associated with each request to determine disposition of that request on an individualized basis. Thus, depending on the maximum allowable time frame associated with each request, it is possible that individual requests may be disposed of at step 150 via different policies even when the resource availability time determined at step 135 is the same for each request, *e.g.*, some requests may be immediately transferred to another system via step 155, some requests may be rejected via step 160 and/or some requests may be re-considered via step 165. It will be understood that combinations of different policies and/or maximum content delivery time frames may be implemented in a variety of ways as necessary to achieve desired disposition of different requests.

As illustrated in FIG. 5, evaluation of the handling policies may lead to step 155 where disposal of the requests for content entails transferring the request to another system for processing when identified required resources of the present system are not immediately available or will not become available within a specified period of time. For example, the request for content may be transferred, *i.e.*, by the system monitor, to a separate content delivery system that is known to have resources immediately available or available within a specified period of time. Alternatively, the request for content may be transferred to the next sequential system in a chain of content delivery systems, and where the next system proceeds through a method similar to method 100 to determine its ability to process the request for content.

Upon transferring the request for content to another system at step 155, method 100 of the system returns to step 105 where a subsequent request for content is awaited. It will be understood that a request for content may be transferred to another system that is similarly configured as the present system (*e.g.*, as in a cluster of similar content delivery systems), or to another type of system that is configured differently (*e.g.*, with differing resource types and/or capabilities). In the case of clustered systems, system monitors (or other appropriate

subsystem modules) of the individual systems of a cluster may be configured to communicate with each other for purposes of sharing system capability and/or resource availability information with other systems to facilitate efficient transference and handling of requests within a system cluster.

5

It will also be understood that inter-system transfer of information (*e.g.*, data, content, requests for content, commands, resource status information, *etc.*) between two or more clustered systems may be managed in a deterministic fashion in a manner similar to that described herein for the intra-system transfer of information between individual processing engines within a single information management system. Deterministic management of inter-system information transfer may be enhanced by distributive interconnection of multiple clustered systems, either internally (*e.g.*, by distributive interconnection of individual distributed interconnects as shown in FIG. 1J) or externally (*e.g.*, by distributive interconnection of individual system network interface processing engines as shown in FIG. 1H). In either case, deterministic transfer of information between individual systems may be managed in a deterministic fashion using any suitable management processing configuration, for example, by using a separate dedicated inter-system management processing module or by using one or more of the existing system monitor processing modules of the individual clustered systems. Individual clusters of systems may in turn be distributively interconnected and information transfer therebetween deterministically managed in a similar fashion, with the number of superimposed levels of deterministic information management being virtually unlimited. Thus, the disclosed methods and systems for deterministic management of information may be advantageously implemented on a variety of scales and/or at multiple system levels as so desired.

25

Another exemplary policy that may be implemented to address situations in which the current system is unable to process a request for content is illustrated at step 160 where the request for content may be rejected. Similar to step 155, a request for content may be so rejected when the identified required resources of the present system are not immediately available or will not be available within a specified period of time. Such a policy may be implemented, for example, where no other separate clustered system is known to be capable of handling the request, and/or is known to have the necessary resources immediately available or available within a specified period of time. In addition to rejecting the request for content, step 155 may also include notifying the source of the request for content of the

30

rejection and of the inability of the present system to process the request for content. Once the request for content has been rejected at step 160, method 100 returns to step 105 where a subsequent request for content is awaited.

5 Yet another exemplary policy that may be implemented based on the evaluation step 150 is indicated generally at step 165. At step 165, a request for content may be re-queued for reconsideration by the present system. Re-queuing of a request may include returning to step 115 where the request for content is re-evaluated to identify the resources required for its processing. Such a re-queue may be desirable, for example, when the identified required
10 resources of the present system and of other systems are not immediately available or will not be available within a specified period of time, but when such resources are anticipated to become available at some point in the future. Furthermore, selected types of requests may also be targeted for re-queue rather than rejection when resources are not available. For example, higher priority requests (*e.g.*, based on SLA or QoS bit set) may be re-queued for
15 expedited processing, while similar but lower priority requests are rejected.

It will be understood with benefit of this disclosure that the three handling policies described above in relation to step 150 are exemplary only, and that not all three need be present at step 150. Further, it will be understood that other types of handling policies may be
20 implemented at step 150 as desired to fit the needs of a particular application environment, including additional or alternative policies for treatment of requests other than those described above, and policies that consider alternate or additional system or subsystem parameters.

25 Turning now to FIG. 2 in greater detail, it will be understood in view of the above discussion that the subsystems of content delivery system 200 may be configured to interact in a deterministic manner if so desired. The ability to manage information in a deterministic fashion may be made possible by virtue of the fact that each subsystem module has a monitoring agent 245 that is aware of one or more subsystem module resources 250 and the
30 utilization of those resources within the respective subsystem and/or overall system 200.

As mentioned above, monitoring agents 245 of each subsystem may be configured to be capable of evaluating the current workload of the resources 250 of the respective subsystem and of reporting the availability of such resources to system monitor 240, either

automatically or upon a polling by system monitor 240. Upon receipt of a request, system monitor 240 and one or more individual monitoring agents 245 may individually or together function to either accept the request and reserve the required resources 250 for the request if the resources are available, or to reject the request if one or more subsystem resources 250
5 required to process the request are not available.

In one embodiment, content delivery system 200 of FIG. 2 may be configured to deterministically deliver content (*e.g.*, one or more video streams) by employing individual monitoring agents 245 in the following roles. Monitoring agent 245 of storage subsystem
10 module 210 may be configured to monitor and reserve such resources as processing engine bandwidth, Fiber Channel bandwidth to content delivery flow path 263, number of available storage devices 265, number of IOPS available per device, and taking into account RAID levels (hardware or software). Monitoring agent 245 of file system caching subsystem
15 module 215 may be configured to monitor and reserve such resources as processing engine bandwidth and memory available for caching blocks of data. Monitoring agent 245 of networking subsystem processing module 205 may be configured to monitor and reserve such resources as processing engine bandwidth, table lookup engine bandwidth, availability of RAM for connection control structures and outbound network bandwidth availability. Monitoring agent 245 of application processing subsystem module 225 may be configured to
20 monitor and reserve processing engine bandwidth. Monitoring agent 245 of other subsystem module 275 may be configured to monitor and reserve resources appropriate to the processing engine features provided therein.

With regard to shared resources 255 of FIG. 2, it will be understood that in a
25 deterministic content delivery embodiment, shared resources 255 may be provided and controlled by individual monitoring agents 245 of each subsystem module sharing the resources 255. Specifically, monitoring agents 245 of each subsystem may be configured to be capable of determining the workload of shared resources 255, and of reserving at least a portion of shared resources 255 that is to be employed by the reserving subsystem to process
30 a request for content. For example, monitoring agent 245 of application RAM subsystem module 220 may be configured to monitor and reserve shared resource 255, such as RAM, for use by streaming application on a per-stream basis as well as for use with connection control structures and buffers.

In addition to deterministic interaction between individual subsystem modules of FIG. 2, communications (*e.g.*, IPC protocol) and data movement between the modules may also be deterministic. In this regard, control messaging and data movement between subsystems may be configured to exhibit deterministic characteristics, for example, by employing one or more
5 distributive interconnects (*e.g.*, switch fabrics) to support deterministic data delivery and communication across the range of delivered loads. In one embodiment, separate distributive interconnects may be employed, for example, to deterministically perform the separate respective functions of inter-process communications path 230 and inter-process data movement path 235 of FIG. 2. In another embodiment, these separate functions may be
10 combined and together deterministically performed by a single distributive interconnect, such as a single distributive interconnect 1080 of FIG. 1A. In either case, a distributive interconnect may be configured to support the bandwidth of communications and/or data (*e.g.*, content) being transmitted or served so that added latency is not incurred.

As shown in FIG. 2, a separate monitoring agent 245 may be employed for each
15 distributive interconnect present in a given system, with each interconnect being treated as a separate subsystem module. For example, in the exemplary embodiment of FIG. 2, monitoring agent 245 of inter-process communication path 230 may be configured to monitor and reserve such resources as the bandwidth available for message passing between
20 subsystems while monitoring agent 245 of inter-process data movement path 235 may be configured to monitor and reserve the bandwidth available for passing data between the various subsystems. In another example, multiple distributive interconnects may be provided with monitoring agents to monitor and reserve either communication or data movement flow paths on an assigned or as-needed basis between subsystem modules, or between other
25 distributive interconnects (*e.g.*, in the case of internally clustered systems). Alternatively, a monitoring agent of a single distributive interconnect may be configured to monitor and reserve message-passing and data-passing bandwidth when these functions are handled by a single distributive interconnect, such as a single switch fabric.

30 Still referring to FIG. 2, method 100 of FIG. 5 may be implemented by system 200 as follows. System 200 begins by waiting for a request at step 105. In this regard, networking subsystem module 205 or some other subsystem module of system 200 may receive a request for content or a request for services from source 260, or from any of the other possible sources previously mentioned. As previously described, a request for content may include

such requests as a request to start a video stream, a request for stored data, etc. A request for services may include, for example, a request for a database query, a request for a process to start, a request for an application to be run, *etc.*

5 At step 110, system monitor 240 filters the request for content as previously described. In this capacity, system monitor 240 may be configured to coordinate deterministic actions of system 200 by acting as a central clearing house or evaluator of content requests, and by directing the disposition of same. Although described in relation to system monitor 240, it will be understood that coordination of deterministic tasks may be performed by any
10 subsystem module or combination of subsystem modules suitable for performing one or more of the tasks described herein as being performed by system monitor 240. For example, filtering tasks may be performed in whole or in part by application processing subsystem module 225. Furthermore, it will also be understood that one or more deterministic coordination tasks may be performed by processors or combinations of processors that are
15 integral and/or external to a given system 200. For example, a processing module (*e.g.*, system monitor 240) integral to a single system 200 may perform the deterministic coordination tasks for a cluster of linked systems. In an alternate example, a separate dedicated external processing module may be employed to perform the deterministic coordination tasks for a single system 200, or a cluster of such systems.

20

 Once a request has been filtered at step 110 and the resources 250 required to process the request have been identified at step 115, system monitor 240 proceeds to step 120 and polls all of the monitoring agents 245 of the subsystem modules having the resources 250 that have been identified as being required to interact to process the given request, and
25 accumulates responses from monitoring agents 245 at step 125. In response to this polling, a given subsystem module may be configured to refuse to take on additional requests unless it currently has, or will have within a specified period of time, the resources 250 available to process the new request without degradation to requests that it is already processing.

30 The monitoring tasks of monitoring agents 245 may be performed by any processor or combination of processors suitable for performing one or more of the monitoring tasks as described elsewhere herein. In this regard, monitoring tasks may be performed by one or more processors integral to a given monitored subsystem module as illustrated in FIG. 2, or may alternatively be performed by one or more processors external to the given subsystem

module, or even external to system 200 itself. Furthermore, it is possible that a combination of monitoring tasks and deterministic coordination tasks may be performed by the same individual processor (*e.g.*, both functions performed by system monitor 240), or by a combination of processors. Thus, it will be understood that the disclosed methods and systems may be implemented using a wide variety of hardware and/or logical configurations suitable for achieving the deterministic management of information as described herein.

After the responses from monitoring agents 245 are accumulated in step 125, system monitor 240 evaluates the responses at step 135 to determine if adequate resources are available as previously described, although evaluation may be accomplished in any other suitable manner, such as by using a different processing module or a combination of processing modules. For example, application processing subsystem module 225 may communicate with system monitor 240 and evaluate responses based on the resource responses or notifications that have been accumulated by system monitor 240 in step 125.

15

As previously mentioned, system monitor 240 may then participate in reserving and queuing the resources of each subsystem at steps 140 and 145 if the monitoring agents 245 of the appropriate subsystems have indicated that they have the identified resources 250 available that are required to process the request. Alternatively, individual monitoring agents 245 may reserve the required resources based upon requirements communicated to monitoring agents 245 by system monitor 240 or other processing module/s. An individual processing queue for each subsystem module may be maintained by its appropriate monitoring agent, and/or a centralized processing queue may be maintained for one or more modules by the system monitor.

25

As previously mentioned with respect to step 150, disposition of requests that a information management system is immediately unable to process or will not be able to process within a specified period of time may be determined by consulting one or more handling policies. For example, a request for content may be rejected in step 160, re-directed to another server 201 with capacity to spare in step 155, or queued for later processing in step 165. As with other exemplary steps of method 100, handling policy evaluation step 150 may be performed by system monitor 240, and/or other suitable processing module/s (*e.g.*, application processing subsystem module 225).

30

The disclosed methods of deterministic information management may be accomplished using a variety of control schemes. For example, in one embodiment an application itself (e.g., video streaming) may be configured to have intimate knowledge of the underlying hardware/resources it intends to employ so as to enable identification, evaluation and reservation of required hardware/resources. However, in another embodiment the operating system employed by an information management system may advantageously be configured to maintain the necessary knowledge of the information management system hardware and hide such details from the application. In one possible embodiment, such an approach may be implemented for more general deployment in the following manner. An operating system vendor or a standards body may define a set of utilization metrics that subsystem vendors would be required to support. Monitoring and reservation of these resources could then be 'built-in' to the operating system for application developers to use. As one specific example, network interface card vendors might be required to maintain percent utilization of inbound and outbound bandwidth. Thus, if a request is received by a content delivery system for delivery of an additional 300 kb/s (kilobit per second) video stream, and the outbound networking path is already 99% utilized, such a request for content may be rejected.

Deterministic management of information has been described herein in relation to particular system embodiments implemented with multiple subsystem modules distributively interconnected in a single chassis system, or in relation to embodiments including a cluster of such systems. However, it will be understood that information may be deterministically managed using a variety of different hardware and/or software types and may be implemented on a variety of different scales. FIG. 6 illustrates just one example of such an alternate embodiment in which the concept of a series of distributively interconnected subsystems may be extrapolated from optimization of resources within a single chassis information management system (e.g., server, router, etc.) to optimization of server resources in a data center 300. Such an implementation may involve deterministically managing communications and information flow between a number of separate devices within data center 300, although it may also be implemented to deterministically manage communication and information flow between similar-type devices integrated into the same chassis.

As shown in FIG. 6, data center 300 may include a device or blade, such as load balancing device 305, that is responsible for load-balancing traffic requests received from

network 307 across a number of servers 310 and/or content routers 311 (*e.g.*, within the same chassis or a number of chassis), and in which load-balancing device 305 communicates with servers 310 and/or content routers 311 over a distributively interconnected control/data path 315. In such an embodiment, load balancing device 305 may communicate with system
5 monitors 320 and 330 of respective servers 310 and content routers 311 to determine whether servers 310 or content routers 311 have resources available. Such resources may include, for example, available bandwidth of storage area networks 312 and/or 313 to handle additional requests. In this regard, load balancing device 305 may filter and evaluate requests, poll data center 300 resources, evaluate the responses and dispose of the requests in a deterministic
10 manner similar to that described elsewhere herein, *e.g.*, for system monitor 240 of FIG. 2.

In a further possible embodiment, one or more of servers 310 and/or content routers 311 may be internally configured with subsystem modules that are distributively interconnected and deterministically managed, for example, in a manner as described in
15 relation to FIGS. 1A and 2. In such an implementation, each server 310 and content router 311 itself (in terms of delivering streams or pages) is capable of monitoring its resources and interacting with an external agent in a way that is analogous to the way that the internal subsystems of individual servers 310 and/or content routers 311 are interacting.

In other further embodiments, the disclosed deterministic information management concept may be applied to many different technologies where the concept of a server may be generalized. For example, implementation of the present invention may apply to a device that routes data between a gigabit Ethernet connection to a Fiber Channel connection. In such an implementation, the subsystems may be a networking subsystem, a Fiber Channel subsystem
25 and a routing subsystem. An incoming request for a SCSI (Small Computer System Interface) block would appear at the networking subsystem. The system monitor would then poll the system devices to determine if resources are available to process the request. If not, the request is rejected, or else the necessary resources are reserved and the request is subsequently processed.

30

Finally, although various embodiments described herein disclose monitoring each individual processing engine of an information management system, such as each subsystem module of content delivery system 200 of FIG. 2, such extensive monitoring may not be necessary in particular application environments. For example, if one or more processing

engines has sufficient resources to handle virtually any workload that the information management system is able to provide, it may be unnecessary to track the availability of those resources. In such an implementation, the processing power that may have been utilized to monitor, poll, track, *etc.* the resources of such a processing engine may be conserved or
5 eliminated. Such a reduction in monitoring and processing power may reduce the overall system cost as well as reduce system design costs.

DIFFERENTIATED SERVICES

10 The disclosed systems and methods may be advantageously employed to provide one or more differentiated services in an information management environment, for example, a network environment. In this regard, examples of network environments in which the disclosed systems and methods may be implemented or deployed include as part of any node, functionality or combination of two or more such network nodes or functionalities that may
15 exist between a source of information (*e.g.*, content source, application processing source, *etc.*) and a user/subscriber, including at an information source node itself (*e.g.*, implemented at the block level source) and/or up to a subscriber node itself. As used herein, the term “differentiated service” includes differentiated information management/manipulation services, functions or tasks (*i.e.*, “differentiated information service”) that may be
20 implemented at the system and/or processing level, as well as “differentiated business service” that may be implemented, for example, to differentiate information exchange between different network entities such as different network provider entities, different network user entities, *etc.*. These two types of differentiated service are described in further detail below. In one embodiment, either or both types of differentiated service may be
25 further characterized as being network transport independent, meaning that they may be implemented in a manner that is not dependent on a particular network transport medium or protocol (*e.g.*, Ethernet, TCP/IP, Infiniband, *etc.*), but instead in a manner that is compatible with a variety of such network transport mediums or protocols.

30 As will be described further herein, in one embodiment the disclosed systems and methods may be implemented to make possible session-aware differentiated service. Session-aware differentiated service may be characterized as the differentiation of information management/manipulation services, functions or tasks at a level that is higher than the individual packet level, and that is higher than the individual packet vs. individual

packet level. For example, the disclosed systems and methods may be implemented to differentiate information based on status of one or more parameters associated with an information manipulation task itself, status of one or more parameters associated with a request for such an information manipulation task, status of one or more parameters associated with a user requesting such an information manipulation task, status of one or more parameters associated with service provisioning information, status of one or more parameters associated with system performance information, combinations thereof, *etc.* Specific examples of such parameters include class identification parameters, system performance parameters, and system service parameters described further herein. In one embodiment, session-aware differentiated service includes differentiated service that may be characterized as resource-aware (*e.g.*, content delivery resource-aware, *etc.*) and, in addition to resource monitoring, the disclosed systems and methods may be additionally or alternatively implemented to be capable of dynamic resource allocation (*e.g.*, per application, per tenant, per class, per subscriber, *etc.*) in a manner as described further herein.

15

Deterministic capabilities of the disclosed systems and methods may be employed to provide “differentiated information service” in a network environment, for example, to allow one or more tasks associated with particular requests for information processing to be provisioned, monitored, managed and/or reported differentially relative to other information processing tasks. The term “differentiated information service” includes any information management service, function or separate information manipulation task/s that is performed in a differential manner, or performed in a manner that is differentiated relative to other information management services, functions or information manipulation tasks, for example, based on one or more parameters associated with the individual service/function/task or with a request generating such service/function/task. Included within the definition of “differentiated information service” are, for example, provisioning, monitoring, management and reporting functions and tasks as described elsewhere herein. Specific examples include, but are not limited to, prioritization of data traffic flows, provisioning of resources (*e.g.*, disk IOPs and CPU processing resources), *etc.*

25
30

As previously mentioned, business services (*e.g.*, between network entities) may also be offered in a differentiated manner. In this regard, a “differentiated business service” includes any information management service or package, of information management services that may be provided by one network entity to another network entity (*e.g.*, as may

be provided by a host service provider to a tenant and/or to an individual subscriber/user), and that is provided in a differential manner or manner that is differentiated between at least two network entities. In this regard, a network entity includes any network presence that is or that is capable of transmitting, receiving or exchanging information or data over a network
5 (e.g., communicating, conducting transactions, requesting services, delivering services, providing information, etc.) that is represented or appears to the network as a networking entity including, but not limited to, separate business entities, different business entities, separate or different network business accounts held by a single business entity, separate or different network business accounts held by two or more business entities, separate or
10 different network ID's or addresses individually held by one or more network users/providers, combinations thereof, etc. A business entity includes any entity or group of entities that is or that is capable of delivering or receiving information management services over a network including, but not limited to, host service providers, managed service providers, network service providers, tenants, subscribers, users, customers, etc.

15

A differentiated business service may be implemented to vertically differentiate between network entities (e.g., to differentiate between two or more tenants or subscribers of the same host service provider/ISP, such as between a subscriber to a high cost/high quality content delivery plan and a subscriber to a low cost/relatively lower quality content delivery
20 plan), or may be implemented to horizontally differentiate between network entities (e.g., as between two or more host service providers/ISPs, such as between a high cost/high quality service provider and a low cost/relatively lower quality service provider). Included within the definition of "differentiated business service" are, for example, differentiated classes of service that may be offered to multiple subscribers. Although differentiated business services
25 may be implemented using one or more deterministic and/or differentiated information service functions/tasks as described elsewhere herein, it will be understood that differentiated business services may be provided using any other methodology and/or system configuration suitable for enabling information management or business services to be provided to or between different network entities in a differentiated manner.

30

As described herein above, the disclosed methods and systems may be implemented to deterministically manage information based at least in part on parameters associated with particular processed information, or with a particular request for information such as a request for content or request for an information service. Examples of such parameters

include, but are not limited to, priority level or code, identity of the requesting user, type of request, anticipated resources required to process the request, *etc.* As will be further described herein below, in one embodiment these deterministic features may be implemented to provide differentiated information service, for example, in the provisioning of resources
5 and/or prioritization of resources for the processing of particular requests or for performing other tasks associated with management of information. In such an implementation, deterministic management may be configured to be user programmable and/or may be implemented at many system levels, for example, below the operating system level, at the application level, *etc.* Such deterministic features may be advantageously implemented, for
10 example, to bring single or multi subscriber class of service and/or single or multi content class of service capability to both single and multi-tenant (*e.g.*, shared chassis or data center) environments.

In one differentiated information service embodiment disclosed herein, differentially
15 managing an individual information processing request relative to other such requests allows provisioning of shared resources on a request-by-request, user-by-user, subscriber-by-subscriber or tenant-by-tenant basis based on SLA terms or other priority level information. Differentially monitoring or tracking resource usage for a particular request or particular user/customer allows reporting and verification of actual system performance relative to SLA
20 terms or other standards set for the particular user or customer, and/or allows billing for shared resource usage to be based on the differential use of such resources by a particular user/customer relative to other users/customers. Thus, differentiation between information requests may be advantageously employed to increase efficiency of information management by allowing processing of a particular request to be prioritized and/or billed according to its
25 value relative to other requests that may be simultaneously competing for the same resources. By providing the capability to differentiate between individual information management/manipulation tasks, maximum use of shared resources may be ensured, increasing profitability for the information management system operator and providing users with information management services that are predictable and prioritized, for example,
30 based on the user's desired service level for a given request. In this way, deterministic information management may be employed to enable service providers to differentiate and optimize customer service levels (*i.e.*, the customer experience) by allocating content delivery resources based on business objectives, such as bandwidth per connection, duration of event, quality of experience, shared system resource consumption, *etc.*

The ability to differentiate between information requests may be especially advantageous during periods of high demand, during which it is desirable that an e-business protect its most valuable customers from unpredictable or unacceptable service levels. As
5 described elsewhere herein, system resources (bandwidth, storage processing, application processing, network protocol stack processing, host management processing, memory or storage capacity, *etc.*) may be adaptively or dynamically allocated or re-allocated according to service level objectives, enabling proactive SLA management by preserving or allocating
10 more resources for a given customer when service levels are approaching SLA thresholds or when system resource utilization is approaching threshold levels, thus assuring SLA performance and generating substantial savings in SLA violation penalties.

Capability to deliver differentiated information service may be implemented using any suitable system architectures, such as one or more of the system architecture
15 embodiments described herein, for example, asymmetrical processing engine configuration, peer-to-peer communication between processing engines, distributed interconnection between multiple processing engines, *etc.* For example, when implemented in an embodiment employing asymmetrical multi-processors that are distributively interconnected, differentiated management and tracking of resource usage may be enabled to deliver
20 predictable performance without requiring excessive processing time. Furthermore, management and tracking may be performed in real-time with changing resource and/or system load conditions, and the functions of management and tracking may be integrated so that, for example, real time management of a given information request may be based on real time resource usage tracking data.

25

The disclosed differentiated service capability may be implemented in any system/subsystem network environment node that is suitable for the manipulation of information, including network endpoint systems, intermediate node systems and endpoint/intermediate hybrid systems discussed elsewhere herein. Such capability may also
30 be implemented, for example, in single or multiple application environments, single or multi CoS environments, *etc.* It will also be understood that differentiated service capability may be implemented across any given one or more separate system nodes and/or across any given separate components of such system nodes, for example, to differentially provision, monitor, manage and/or report information flow therebetween. For example, the disclosed systems

and methods may be implemented as a single node/functionality of a multi-node/functionality networking scheme, may be implemented to function across any two or more multiple nodes/functionalities of a multi-node/functionality networking scheme, or may be implemented to function as a single node/functionality that spans the entire network, from
5 information source to an information user/subscriber.

As will be further described herein, the disclosed differentiated services may be advantageously provided at one or more nodes (*e.g.*, endpoint nodes, intermediate nodes, *etc.*) present outside a network core (*e.g.*, Internet core, *etc.*). Examples of intermediate nodes
10 positioned outside a network core include, but are not limited to cache devices, edge serving devices, traffic management devices, *etc.* In one embodiment such nodes may be described as being coupled to a network at “non-packet forwarding” or alternatively at “non-exclusively
packet forwarding” functional locations, *e.g.*, nodes having functional characteristics that do not include packet forwarding functions, or alternatively that do not solely include packet
15 forwarding functions, but that include some other form of information manipulation and/or management as those terms are described elsewhere herein.

Examples of particular network environment nodes at which differentiated services (*i.e.*, differentiated business services and/or differentiated information services) may be
20 provided by the disclosed systems and methods include, but are not limited to, traffic sourcing nodes, intermediate nodes, combinations thereof, *etc.* Specific examples of nodes at which differentiated service may be provided include, but are not limited to, switches, routers, servers, load balancers, web-cache nodes, policy management nodes, traffic management nodes, storage virtualization nodes, node between server and switch, storage
25 networking nodes, application networking nodes, data communication networking nodes, combinations thereof, *etc.* Specific examples of such systems include, but are not limited to, any of the information delivery system embodiments described elsewhere herein, including those described in relation to FIGS. 1A and 2. Further examples include, but are not limited to, clustered system embodiments such as those illustrated in FIGS. 1G through 1J. Such
30 clustered systems may be implemented, for example, with content delivery management (“CDM”) in a storage virtualization node to advantageously provide differentiated service at the origin and/or edge, *e.g.*, between disk and a client-side device such as a server or other node.

Advantageously, the disclosed systems and methods may be implemented in one embodiment to provide session-aware differentiated information service (*e.g.*, that is content-aware, user-aware, request-aware, resource-aware, application aware, combinations thereof, *etc.*) in a manner that is network transport independent. For example, differentiated information service may be implemented at any given system level or across any given number of system levels or nodes (*e.g.*, across any given number of desired system components or subsystem components) including, but not limited to, from the storage side (spindle) up to the WAN edge router level, from the storage side up to the service router level, from the storage side up to the core router level, from server to router level (*e.g.*, service router, edge router, core router), *etc.* Furthermore, the disclosed systems and methods may be implemented to provide differentiated information service in such environments on a bi-directional information flow basis (*e.g.*, they are capable of differentially managing both an incoming request for content as well as the outgoing delivery of the requested content), although uni-directional differentiated information service in either direction is also possible if so desired. The disclosed differentiated services not only may be provided at any given system level or across any given number of system levels or nodes as described above, but as described further herein also may be implemented to provide functions not possible with conventional standards or protocols, such as Ethernet priority bits, Diffserv, RSVP, TOS bits, *etc.* TCP/IP and Ethernet are conventional communication protocols that make use of priority bits included in the packet, *e.g.*, Ethernet has priority bits in the 802.1p/q header, and TCP/IP has TOS bits.

In one specific implementation, a serving endpoint may be provided with the ability to not only distinguish between a number of service classes of traffic/application/service, but also to make admission-control and other decisions based on this information. In such a case, policies may be employed to direct the operational behavior of the server endpoint.

In another specific implementation, statistical data gathering and logging may be employed to track resource provisioning and/or shared resource usage associated with particular information manipulation tasks such as may be associated with processing of particular requests for information. Data collected on resource provisioning and shared resource usage may in turn be employed for a number of purposes, including for purposes of billing individual users or suppliers according to relative use of shared resources; tracking actual system performance relative to SLA service guarantees; capacity planning; activity

monitoring at the platform, platform subsystem, and/or application levels; real time assignment or reassignment of information manipulation tasks among multiple sub-systems and/or between clustered or linked systems; fail-over subsystem and/or system reassignments; *etc.* Such features may be implemented in accordance with business objectives, such as bandwidth per subscriber protection, other system resource subscriber protection, chargeable time for resource consumption above a sustained rate, admission control policies, *etc.*

It will be understood that differentiated information service functions, such as resource management and other such functions described herein, may be performed at any system level or combination of system levels suitable for implementing one or more of such functions. Examples of levels at which differentiated information service functions may be implemented include, but are not limited to, at the system BIOS level, at the operating system level, service manager infrastructure interface level. Furthermore, differentiated information service capability may be implemented within a single system or across a plurality of systems or separate components.

A simplified representation showing the functional components of one exemplary embodiment of an information management system 1110 capable of delivering differentiated information service is shown in FIG. 7. Functional components of system 1110 include hardware system architecture 1120, system BIOS 1130, operating system 1140, management application program interface API 1160, application API 1150, network content delivery applications 1180, and differentiated service management infrastructure 1190. System architecture 1120 may be any information system architecture having deterministic and/or asymmetric processing capabilities, for example, as described elsewhere herein.

In one embodiment, system architecture 1120 may include multiple system engines that are distributively interconnected, for example, in a manner as illustrated and described relation to FIG. 1A or FIG. 2. System architecture 1120 may also include system software that has state knowledge of resource utilization within the architecture and that is capable of imparting deterministic capabilities (*e.g.*, instructions) to system architecture 1120, for example, by deterministically controlling interaction between distributively interconnected system engines of system architecture 1120. As described in relation to FIG. 2, monitoring agents 245 may be provided within each subsystem module and the system architecture 1120

may include a system monitor 240 that performs system management functions, such as maintaining service policies, collecting real-time utilization data from all subsystem modules, *etc.* System architecture 1120 may be capable of supporting a discrete family of applications or multiple concurrent applications (*e.g.*, streaming applications such as QuickTime, RealNetwork and/or Microsoft Media, edge cache-related, NAS-related, *etc.*).

System calls may be employed to OS-extensions to determine characteristics of one or more parameters associated with processing engines/resources of a system architecture 1120 (*e.g.*, as in FIGS. 1A and 2) so as to enable deterministic information management and/or to provide differentiated information service functions in a manner described elsewhere herein. In one embodiment, calls to OS-extensions may be made to implement necessary system resource utilization and user priority information. As an example, referring back to FIG. 2, monitoring agent 245 of storage subsystem module 210 may be employed to monitor the workload on each content source 265, as well as the status of other resources 250 of module 210 such as workload on the system CPU doing the caching and block operations, as well as the available memory for caching. Monitoring of this information makes possible calls to storage processing subsystem module 210, for example, to determine availability of IOPs on the drive(s) upon which a requested content stream resides. Similarly, calls may be made to networking subsystem processor module 205 having its own monitoring agent 245 to determine how much bandwidth on the outbound connection is already being used, as well as to determine if sufficient additional resources are available to add another connection. A call may also be made to determine whether sufficient RAM is available in file system cache subsystem module 215 to support this operation, which is also provided with a monitoring agent 245.

25

As will be described in further detail below, system calls may also be employed to understand parameters, such as priority, associated with individual connections, requests for information, or specific content sets. Examples of such parameters include, but are not limited to, those associated with classes based on content, classes based on application, classes based on incoming packet priority (*e.g.*, utilizing Ethernet priority bits, TCP/IP TOS bits, RSVP, MPLS, *etc.*), classes based on user, *etc.* It will be understood that the possible system calls described above are exemplary only, and that many other types of calls or combinations thereof may be employed to deterministically manage information and/or to provide differentiated information service capability in a manner as described elsewhere

herein. It will also be understood that where a system monitor 240 collects and maintains monitored subsystem module information, system calls may be handled by system monitor 240 rather than by the individual subsystem modules as described above.

5 Thus, the capability of monitoring individual subsystem or processing engine resources provided by the disclosed deterministic information management systems may be advantageously implemented in one embodiment to make possible policy-based management of service classes and guarantees in a differentiated manner from a server endpoint. One possible implementation of such an embodiment may be characterized as having the
10 following features. All subsystems that represent a potential bottleneck to complete the requested information management are configured to support prioritized transactions. Any given transaction (*e.g.*, video stream, FTP transfer, *etc.*) is provided a unique ID that is maintained in the OS or in the application, which includes a priority indicator (or other class of service indicator). OS extensions or other API's are provided for applications to access
15 this information, and an I/O architecture configured to support prioritized transactions.

As further illustrated in FIG. 7, optional system BIOS 1130 may be present to manage system calls made to processing engines of architecture 1120 from applications 1180 through optional APIs 1160 and/or 1150 and through operating system 1140. In this regard system
20 BIOS 1130 enables applications 1180 to utilize architecture 1120 in a deterministic manner by providing access to data presented by individual engines or subsystem modules of architecture 1120, and by ensuring calls are made properly to individual engines or subsystem modules of architecture 1120 in a manner as described above. System BIOS 1130 may make
25 this possible, for example, by responding to application requests for resources with availability information, rerouting information, or SLA choice information. System BIOS 1130 may be implemented as hardware, software or a combination thereof, and may include the IPC.

In one embodiment, operating system 1140 may be a conventional operating system
30 (*e.g.*, Linux-based operating system), to which applications 1180 may be directly ported or may be ported through optional application APIs 1150 and/or 1160 as described below. In this regard, optional APIs 1150 may be provided to enhance performance of one or more applications on system 1110, including, but not limited to, network content delivery applications 1180 as illustrated in FIG. 7. As shown, examples of network content delivery

applications include, but are not limited to, applications related to HTTP, streaming content, storage networking, caching, protocol software level switching (*e.g.*, Layer 3 through Layer 7), load balancing, content delivery management (CDM), *etc.* It will be understood that these listed applications are exemplary only, and that other applications or other combinations of applications (*e.g.*, greater or lesser number, and/or combinations of different applications and/or types of applications, *etc.*) are also possible. Just a few example of other possible network content delivery applications or internet applications include, but are not limited to, applications related to database, FTP, origin, proxy, other continuous content, *etc*

10 Although some performance advantages are possible when conventional applications 1180 are directly ported to conventional operating system 1140, application and operating system functions are thus executed in a manner that is essentially unaware of the asymmetric and deterministic capabilities of architecture 1120. Thus, optional application APIs 1150 may be configured as system and/or subsystem-aware functional components that when 15 present at the application/operating system interface may provide significant enhancement and accelerated system performance by streamlining communication and data flow between the application level and the other levels of system 1110 in a manner as described elsewhere herein. Optional management APIs 1160 may also be present to perform a similar function at the operating system/BIOS interface. Although illustrated in FIG. 7 as separate functional 20 components from conventional operating system 1140, it will be understood that functionality of BIOS 1130, API 1160 and/or API 1150 may be built-into or resident within an operating system.

In yet another embodiment, one or more of applications 1180 may be written as 25 system and/or subsystem-aware components themselves, further enhancing and accelerating system performance. For example, code may be included in a selected application that not only utilizes calls into operating system 1140 that indicate the relative priority of each connection or request, but that also utilizes calls indicating the availability of necessary resources or subsystems in architecture 1120 to support each stream. In this manner, the 30 application is enabled to make smart decisions about how to handle various classes of customers in times of system congestion.

Although not illustrated, an operating system may be configured to enable deterministic/differential system performance through a direct interface between applications

1180 and system architecture 1120, *e.g.*, without the need for BIOS 1130. In such a case, system calls may be implemented and managed in the operating system itself. Advantageously, the unique deterministic nature of the system architectures disclosed herein (*e.g.*, FIGS. 1A and 2) make possible such operating system features by enabling monitoring
5 on the subsystem level without excessive processing overhead.

Still referring to FIG. 7, differentiated service management infrastructure 1190 may be provided to enable differentiated service functions or tasks including, but not limited to, service provisioning, service level agreement protocols, QoS and CoS policies, performance
10 monitoring, reporting/billing, usage tracking, *etc.* These particular management functions will be described in further detail herein, however it will be understood that any other information management function/s that act in a way to differentiate service and/or flow of information may also be implemented using the disclosed systems and methods.

15 Individual differentiated information service functions of service management infrastructure 1190 may be performed within system 1110 (*e.g.*, by a system management processing engine 1060 described elsewhere herein) and/or may be performed a separate network-connected management system/s (*e.g.*, via interface support to an external data center for service management), such as a separate system running IBM Tivoli, HP Open
20 View, *etc.* For example, in one embodiment service provisioning, QoS, and performance monitoring functions may be performed by a host processing unit 1122 (*e.g.*, a system management processing engine 1060 as described elsewhere herein) within architecture 1120, while billing and usage tracking functions may be performed by a separate externally connected network component/system based on performance monitoring data supplied by
25 system 1110 (*e.g.*, via a management interface 1062). When information is so provided to an external system for further processing, such information may be output (*e.g.*, such as flat file, SNMP, web-based, CLI, *etc.*), or selected management APIs 1160 may be present to interface and enhance communications between system 1110 and the external system by providing performance monitoring/usage data in an optimized format for the particular application
30 type/s running on the external system.

It will be understood that FIG. 7 illustrates only one exemplary functional representation of an information management system capable of delivering differentiated service, and that differentiated service capability may be implemented in a variety of other

ways, using other combinations of the functional components illustrated in FIG. 7, and/or using different functional components and various combinations thereof. For example, operating system 1140 and/or BIOS 1130 may be extended beyond the boundary of system 1110 to deterministically interface with systems, subsystems or components that are external to system 1110, including systems, subsystems or components that are physically remote from system 1110 (e.g., located in separate chassis, located in separate buildings, located in separate cities/countries *etc.*) and/or that are not directly coupled to system 1110 through a common distributed interconnect. Examples of such external systems, subsystems or components include, but are not limited to, clustered arrangements of geographically remote or dispersed systems, subsystems or components.

FIG. 8 illustrates one embodiment of a method for implementing differentiated service capability based on defined business objectives, for example, in a competitive service differentiation implementation. As shown, the method includes defining business objectives in step 1210, defining a system configuration in step 1220, purchasing and installing the configured system in step 1230, provisioning service in step 1240, monitoring/tracking service in step 1250, managing information processing in step 1260 and/or reporting service information in step 1270. It will be understood that the method steps of FIG. 8 are exemplary only, and that embodiments of the disclosed systems and methods may be implemented with any one of the steps, or with any combination of two or more of the steps illustrated in FIG. 8. It will be further understood that the disclosed methods and systems may be implemented with other steps not illustrated in FIG. 8, or with combinations of such other steps with any one or more of the steps illustrated in FIG. 8.

The embodiment of FIG. 8 may be implemented, for example, to allow a host service provider ("HSP") to use the disclosed methods and systems to provide one or more differentiated business services for one or more tenants, who in turn may provide services to subscribers. Examples of HSP's include, but are not limited to, a data center owner who provides co-located or managed services to one or more tenants. Examples of tenants include, but are not limited to, xSPs (such as ISP, ASP, CDSP, SSP, CP or Portal), Enterprise providers providing service to employees, suppliers, customers, investors, *etc.* A tenant may be co-located or under HSP Managed Service. Subscribers include, for example, residential and/or business customers who access a network content delivery system to play audio/video streams, read web pages, access data files, *etc.* It will be understood that these examples are

exemplary only, and that the embodiment of FIG. 8 may be implemented to allow entities other than an HSP to provide differentiated business services using the disclosed methods and systems.

5 Referring now to FIG. 8 in more detail, business objectives may be defined in step 1210 and may include objectives such as service definition objectives (*e.g.*, delivery of continuous broadcast, non-continuous and/or stored information, management of unique/non-unique information, anticipated number of simultaneous subscribers and/or simultaneous streams, event (*e.g.*, stream) duration, system resources (*e.g.* bandwidth) per subscriber, *etc.*),
10 service differentiation objectives (*e.g.*, horizontal and/or vertical differentiation between different entities, differentiation based on quality/cost plan, differentiation based on type of information request, differentiation based on user/subscriber and/or user/subscriber characteristics, *etc.*), service level agreement objectives (*e.g.*, CoS priority, QoS *etc.*), service metering objectives and/or service monitoring objectives (*e.g.*, subscriber flow performance,
15 tenant class performance or individual tenant performance, aggregate system performance, individual subsystem performance, *etc.*), service reporting objectives (*e.g.*, billing log generation, tracking adherence to SLA, tracking utilization of system and/or subsystems, tracking subscriber and/or content activity, *etc.*), information processing management objectives (*e.g.*, admission and/or prioritization of requests based on tenant class or individual
20 tenant identity, overflow treatment, *etc.*), and/or service classes (*e.g.*, desired number and/or types of service classes, *etc.*). Such objectives may be defined in any manner suitable for communicating the same, for example, from a system purchaser/user to an information management system supplier. Types of objectives that may be defined include one or more pre-defined types of variables, and/or may include one or more custom objective aspects.

25

Still referring to FIG. 8, a system configuration may be defined in step 1220 based at least partly on business objectives defined in step 1210, for example, by a system manufacturer based on system objectives provided by a purchaser in step 1210. In this regard step 1220 may include, but is not limited to, planning a system configuration to meet
30 objectives such as anticipated capacity, and engineering system characteristics to implement the defined configuration, *etc.* For example, a system configuration may be planned to meet capacity objectives including, but not limited to, anticipated system throughput objectives, service level protection objectives, maximum number of customer objectives, *etc.* Examples of solution engineering parameters include, but are not limited to, implementing the system

configuration by engineering types and number of system and subsystem hardware components, quality of service objectives, billing and metering objectives, *etc.* In one exemplary embodiment, specific examples of information system characteristics that may be so configured for a content delivery system include, but are not limited to, storage characteristics (*e.g.*, storage capacity, mirroring, bandwidth attach rate, protocol, *etc.*);
5 compute characteristics (*e.g.*, CPU speed, management responsibility, application processing capability, *etc.*); and network characteristics (*e.g.*, admission control, policy management, number of classes, *etc.*), combinations thereof, *etc.*

10 Advantageously, embodiments of the disclosed systems may be configured in consideration of many factors (*e.g.*, quality of service capability, desired SLA policies, billing, metering, admission control, rerouting and other factors reflective of business objectives) that go beyond the simple capacity-oriented factors considered in traditional server design (*e.g.*, anticipated number of requests per hour, duration of stream event, *etc.*).
15 An information management system may be so configured in this manner based on verbal or written communication of such factors to a system supplier and system configuration accomplished by the supplier based thereupon, and/or a system may be configured using an automated software program that allows entry of such factors and that is, for example, running locally on a supplier's or customer's computer or that is accessible to a customer via
20 the Internet.

In one exemplary embodiment, possible system configurations that may be provided in step 1220 based on business objectives or other defined variables include, but are not limited to, configuration of subsystem components within a single box or chassis (*e.g.*, using
25 subsystem modules that are pluggable into a distributed interconnect backplane), configuration of a cluster of systems in a box to box manner (*e.g.*, internally or externally clustered systems), configuration of data system components using distributively interconnected data center components, *etc.* Possible system configurations include, but are not limited to, data center system configurations or other content points of presence ("POPs")
30 suitable for providing delivery traffic management policies and/or for implementing SLA policies to multiple components of a data center concurrently (*e.g.*, switch, storage, application server, router, *etc.*), and to any selected point/s therebetween. Examples of such content POPs include, but are not limited to, telephone central offices, cable head-ends, wireless head-ends, *etc.* Thus a system such as shown in FIGS. 1A or 2 may be configured

with an optimization of the allocation of resources between processor engines, the types and quantity of processor modules per engine, *etc.*

As further shown in FIG. 8, system configuration may be defined or modified in step 5 1220 based at least partly on service monitoring information obtained in step 1250. For example, an existing system configuration may be modified at least partly on service monitoring information obtained for that same system while in actual operation. A new system may be configured based on service monitoring information obtained for one or more existing system/s while in actual operation (*e.g.*, for existing systems similar to the new 10 system and/or for systems operating under network conditions similar to the anticipated network conditions for the new system). Service monitoring step 1250 is described in further detail below, and includes, but is not limited to, historical tracking of system performance parameters such as resource availability and/or usage, adherence to provisioned SLA policies, content usage patterns, time of day access patterns, *etc.* In this regard step 1220 may include, 15 but is not limited to, capacity planning and/or solution engineering based on historically monitored system throughput, service level adherence, maximum number of concurrent subscribers, *etc.*

It will be understood that a system configuration definition may be based on any 20 desired combination of business objective information and service monitoring information. In this regard, one or more individual monitored performance parameters (*e.g.*, resource availability and/or usage, adherence to provisioned SLA policies, content usage patterns, time of day access patterns, or other parameters anticipated to be similar for the new system) may be combined with one or more individual business objectives (*e.g.*, objectives reflecting 25 performance parameters expected to differ for the new system, new service differentiation objectives, new service level agreement objectives, new service metering objectives, new service monitoring objectives, new service reporting objectives new information processing management objectives, and/or new service class information, *etc.*). Further, it will be understood that such service monitoring information and/or business objective information 30 may be varied and/or combined in many ways, for example, to “trial and error” model different implementation scenarios, *e.g.*, for the optimization of the final configuration.

Turning temporarily from FIG. 8 to FIGS. 9A-9D, illustrated are exemplary embodiments of information management configurations of the many different configurations

that are possible using the disclosed systems and methods. These exemplary embodiments serve to illustrate just a few of the many configurations in which the disclosed systems and methods may be employed to provide deterministic information management and/or delivery of differentiated services, such as differentiated information services or differentiated business services. In addition to the illustrated embodiments, It will be understood that the disclosed methods and systems described herein (*e.g.*, including the embodiments of FIGS 9A-9D) may be employed in a variety of network and/or information management environments including, but not limited to, in edge network environments, direct broadcast network environments, *etc.* For example, the disclosed methods and systems may be implemented in endpoint, intermediate and/or edge node devices that are interconnected to or form a part of an edge network, as well as in one or more nodes within an edge node backbone. In this regard, an edge network may be wired, wireless, satellite-based, *etc.*

As an example, FIG. 9A illustrates multiple users 1410 that are connected to a network 1400, which may be a LAN or a WAN such as the Internet. An endpoint information management node 1440 (*e.g.*, network endpoint content delivery system) is shown connected to network 1400 via intermediate nodes 1430 that may be, for example, routers, load balancers, web switches, *etc.* Optional content source 1450 is also shown connected to endpoint information management node 1440. In the embodiment of FIG. 9A, differentiated information services and/or differentiated business services may be delivered to one or more of users 1410 from an origin serving point (*e.g.*, endpoint information management node 1440), for example, when system 1440 is configured as a deterministic system such as that described in relation to FIGS. 1A and 2. In such an embodiment, endpoint information management node controls the information source and may be configured to be capable of handling incoming packets and/or outgoing traffic generated by the incoming packets in a differentiated manner based on parameters or classifications associated with the packets. Such an endpoint information management node may also be capable of marking or tagging outgoing packets with classification information for use by other intermediate or core network nodes.

30

In an alternate embodiment of FIG. 9A, nodes 1430, 1440 and 1450 of FIG. 9A may be components of an information management data center 1420 or other system capable of performing one or more of the indicated functions in a deterministic manner, for example, as described in relation to FIG. 6. In such a case, differentiated information services and/or

differentiated business services may be provided through the data center and delivered to the network core with no other intermediate equipment. Both of the described embodiments of FIG. 9A (*i.e.*, endpoint information management node 1440 or information management data center node 1420) may be configured to manage information (*e.g.*, control system behavior, and serve and deliver content) in a differentiated fashion. Thus, as FIG. 9A indicates, the disclosed systems and methods may be implemented, for example, to provide differentiated service in a content delivery system/server role, or in a device that converges from the content source (*e.g.*, storage disk) to the network.

FIG. 9B illustrates multiple users 1610 that are connected to a network 1602, which may be a LAN or a WAN such as the Internet. Also shown is an intermediate traffic management node 1620 that is present between a conventional data center/content server 1630 and the core of network 1602, and which may be configured to have one more distributive and/or deterministic features of an information management system as described elsewhere herein (*e.g.*, network interface processing engine, *etc.*). In this embodiment, traffic management node 1620 does not control the information source (*e.g.*, content source) but may be configured as a “gate keeper” to perform such session-aware differentiated service functions or tasks as session-aware service level management, session-aware classification and logging of traffic between the network core and conventional data center/content server 1630. Specific examples of differentiated service functions or tasks that may be performed by such a traffic management node include, but are not limited to, redirection decisions, packet classification, tracking and billing functions relative to traffic flow through traffic management node 1620, policy-equipped router, policy-based switch, *etc.* Although not shown, it will be understood that other optional intermediate nodes (*e.g.*, edge routers, *etc.*) may be present between traffic management node 1620 and network 1602 if so desired, that traffic management node 1620 may be subsystem component of a router, *etc.*

FIG. 9C illustrates multiple edge information management nodes 1520 that are connected to a network 1502, which may be a LAN or a WAN such as the Internet. Also shown are multiple users 1510 that may be connected to network 1502 in a manner similar to that shown in FIGS. 9A and 9B. Edge information management nodes 1520 may be of any system configuration suitable for performing information management functions/tasks, for example, as described elsewhere herein. Specific examples of types of edge information management nodes that are possible include, but are not limited to, edge content delivery

nodes, edge application processing nodes, content delivery and/or application processing nodes associated with an edge network, edge content cache and/or replication nodes, *etc.* As shown, an edge information management node may be configured to interface with network 1502 to receive and fulfill requests for information management, such as content delivery or application processing. In this regard, an edge content delivery node may be configured to have a content source, as well as other processing engines, such as those described in relation to FIGS. 1A and 2, and/or may be configured to perform differentiated service functions or tasks as described elsewhere herein.

10 In FIG. 9C, multiple edge information management nodes 1520 are shown interconnected with an intelligent signal path or network IPC 1530 that links nodes 1520 in a clustered configuration, for example, in a manner to achieve the benefits and functionalities of clustered configurations described elsewhere herein. In this regard, signal path 1530 represents any communication device or method that is suitable for linking multiple nodes 1520 including, but not limited to, wired connection path, wireless communication path, virtual connection path across network 1502, standards-based signaling techniques, proprietary signaling techniques, combinations thereof, *etc.* Signal path 1530 may be present as shown to enable deterministic and intelligent communication between the clustered nodes 1520 of FIG. 9C, thus enabling differentiated information services and differentiated business services to be delivered from edge endpoint to the core of network 1502 without the need for intermediate nodes such as routers, load balancers, servers, *etc.*

It will be understood that two or more nodes 1520 may be physically remote components located in a common facility, such as phone or communication system office with access to various forms of communication, *e.g.*, DSL, wireless, *etc.* Alternatively, or in addition to physically remote nodes located in a common facility, one or more of nodes 1520 may be physically remote from one or more other nodes located, in separate facilities of the same building, facilities in different buildings within the same campus, *etc.* Nodes that are physically remote from each other may also include nodes in locations that are geographically remote from each other (*e.g.*, facilities in different buildings within the same city, facilities in different cities, facilities in different states, facilities in different countries, ground and space satellite facilities, *etc.*) In any case, it is possible that two or more nodes 1520 may be interconnected as part of an edge network configuration.

In one example, the information management embodiment of FIG. 9C may function in a manner that enables a given user 1510 to be served from the particular information management node 1520 that corresponds, for example, to a node containing the specific information requested by the user, a node assigned to particular SLA policies associated with the user or the user's request (*e.g.*, allowing particular nodes 1520 to maintain excess resources for immediately and quickly serving requests associated with high cost/high quality SLA policies), and other nodes 1520 having oversubscribed resources that must be allocated/queued for more slowly serving requests associated with lower cost/lower quality SLA policies, *etc.*

10

Also possible are configurations of separate processing engines, such as those of FIG. 1A or 2, that are distributively interconnected across a network, such as a LAN or WAN (*e.g.*, using the disclosed distributed and deterministic system BIOS and/or operating system) to create a virtual distributed interconnect backplane between individual subsystem components across the network that may, for example, be configured to operate together in a deterministic manner as described elsewhere herein. This may be achieved, for example, using embodiments of the disclosed systems and methods in combination with technologies such as wavelength division multiplexing ("WDM") or dense wavelength division multiplexing ("DWDM") and optical interconnect technology (*e.g.*, in conjunction with optic/optic interface-based systems), INFINIBAND, LIGHTNING I/O or other technologies. In such an embodiment, one or more processing functionalities may be physically remote from one or more other processing functionalities (*e.g.*, located in separate chassis, located in separate buildings, located in separate cities/countries *etc.*). Advantageously such a configuration may be used, for example, to allow separate processing engines to be physically remote from each other and/or to be operated by two or more entities (*e.g.*, two or more different service providers) that are different or external in relation to each other. In an alternate embodiment however, processing functionalities may be located in a common local facility if so desired.

20

30

FIG. 9D illustrates one possible embodiment of deterministic information management system 1302 having separate processing engines 1310, 1320 and 1330 distributively interconnected across network 1340 that is equipped with fiber channel-based DWDM communication equipment and flow paths 1350 in combination with optic/optic interfaces. In this embodiment, functions or tasks of a system management processing engine

may be performed by host processing functionality 1330 located in city A and may include, for example, billing, metering, service level management (SLM) and CDM functions or tasks. Functions or tasks of a storage management processing engine may be performed by storage service provider (SSP)/storage farm functionality 1310 located in city B, functions or tasks of an application processing engine may be performed by application service provider (ASP)/compute farm functionality 1320 located in city C, *etc.* For example, a request for content may be received from a user 1360 by host processing functionality 1330. Host processing functionality 1330 may then process the request and any SLA-related information associated with the request, and then notify the appropriate storage service provider functionality 1310 to deliver the requested content directly to user 1360. In a similar manner, asymmetric, deterministic and/or direct path information management flow may advantageously occur between any two or more processing engines that may be present on a network and interconnected via a virtual distributed interconnect backplane.

Advantages offered by the network-distributed processing engines of the embodiment of FIG. 9D include the ability of a service provider to focus on one or more particular aspects of service delivery/utility (*e.g.*, content storage, application processing, billing/metering, *etc.*) without having to worry about other infrastructure components that are maintained by other service providers. Thus, shared resources (*e.g.*, storage capacity, processing capacity, *etc.*) may be purchased and virtually exchanged (*e.g.*, with usage tracking of same) between service providers on an as-needed basis, thus allowing real time maximization of resource utilization and efficiency, as well as facilitating real time allocation of resources based on relative value to the network community. Advantageously then, a service provider need only consume an amount of a given resource as needed at any given time, and without having to maintain and waste excess resources that would otherwise be required to ensure adequate performance during periods of peak resource demand. Further, a given provider is enabled to sell or exchange any excess resources maintained by the provider during periods of lower demand, if the characteristics of the provider's business change, *etc.*

It will be understood that the individual components, layout and configuration of FIG. 9D is exemplary only, and that a variety of different combinations and other system configurations are possible. Thus, any number and/or type of system components suitable for performing one or more types of processing engine functions or tasks, may be provided in communication across a network using any connection/interface technology suitable for

providing distributed interconnection therebetween, *e.g.*, to allow deterministic information management and/or differentiated services to be provided as described elsewhere herein.

In one embodiment a virtual distributively interconnected system may be configured
5 to allow, for example, system management functions (*e.g.*, such as billing, data mining, resource monitoring, queue prioritization, admission control, resource allocation, SLA compliance, *etc.*) or other client/server-focused applications to be performed at one or more locations physically remote from storage management functions, application processing functions, single system or multi network management subsystems, *etc.* This capability may
10 be particularly advantageous, for example, when it is desired to deterministically and/or differentially manage information delivery from a location in a city or country different from that where one or more of the other system processing engines reside. Alternatively or in addition, this capability also makes possible existence of specialized facilities or locations for handling an individual processing engine resource or functionality, or subset of processing
15 engine resources or functionalities, for example, allowing distributed interconnection between two or more individual processing engines operated by different companies or organizations that specialize in such commodity resources or functionalities (*e.g.*, specialized billing company, specialized data mining company, specialized storage company, *etc.*).

20 It will be understood that in the delivery of differentiated services using the disclosed systems and methods, including those illustrated in FIGS. 9A-9D, any packet classification technology (*e.g.*, WAN packet classification technology) that is suitable for classifying or differentiating packets of data may be employed to enable such delivery of differentiated services. Such technologies may be employed to allow the disclosed systems and methods to
25 read incoming packet markings/labels representative of one or more policy-indicative parameters associated with information management policy (*e.g.*, class identification parameters, *etc.*), to allow the disclosed systems and methods to mark or tag outgoing packets with markings/labels representative of one or more policy-indicative parameters associated with information management policy, or a combination thereof. With regard to packet
30 classification technologies, the disclosed differentiated service functionalities may be implemented using principals that are compatible with, or that apply to, any suitable types of layer two through layer seven packet classification technologies including, but not limited to, Ethernet 802.1 P/Q, Diffserv, IPv6, MPLS, Integrated Services (RSVP, *etc.*), ATM QoS, *etc.* In one embodiment, the disclosed systems and methods may be advantageously enabled to

perform such packet classification functionalities by virtue of the presence and functionality of a network interface processing engine as is described in relation to FIGS. 1A and 2 herein.

Thus, the disclosed systems and methods may be implemented to not only provide
5 new and unique differentiated service functionalities across any given one or more separate network nodes (*e.g.*, in one or more nodes positioned outside a network core), but may also be implemented in a manner that interfaces with, or that is compatible with existing packet classification technologies when applied to information traffic that enters a network core. However, it will be understood that the disclosed systems and methods may be
10 advantageously implemented to deliver session-aware differentiated service in information management environments that is not possible with existing packet classification technologies and existing devices that employ the same (*e.g.*, that function at the individual packet level, or at the individual packet vs. individual packet level).

15 It is possible to employ packet classification technologies in a variety of different ways to perform the desired differentiated service functions or tasks for a given implementation, including each of the embodiments illustrated in FIGS. 9A-9D. For example, an endpoint information management system 1440 of FIG. 9A may search incoming packets for tags or markings representative of one or more parameters and handle
20 each such packet according to a policy associated with the parameter/s. In this regard, each incoming packet may be differentially handled, for example, in a deterministic manner as previously described.

Similarly, outgoing packets may be classified by the endpoint information
25 management system 1440 by marking the outgoing packets with labels or tags that are related, for example, to service and/or application information or other parameters associated with the packet, and that indicate how the packet should be handled by one or more other components of the edge and/or core of network 1400. An endpoint information management system 1440 may then deliver the labeled packets to the intermediate nodes 1430 and core of
30 network 1400, where the packet labels may be read by other nodes, such as routers, and routed/treated in a manner dictated by the individual labels or markings associated with each packet (*e.g.*, queue position dictated by MPLS tag, Diffserv tag, IPv6 tag, *etc.*). Advantageously, when endpoint information management system 1440 is configured to be application-aware (*e.g.*, as described in relation to the systems of FIGS. 1A and 2), packet

classification may advantageously be made in way that is application-aware. A similar packet classification methodology may be employed in data center embodiments, such as data center 1420 of FIG. 9A. In such embodiments, classified outgoing packets may be delivered directly to core component/s of network 1400. It will also be understood, however, that the disclosed systems and methods may be practiced in which one or more conventional types of packet classification functions are performed by external intermediate nodes (e.g., conventional intermediate edge routing nodes), rather than the above-described packet classification functions of the disclosed information management systems, or a combination of the two may be employed.

10

Similar packet classification methodology may be employed for incoming and/or outgoing packets by edge information management nodes 1520 of FIG. 9C, or by any other information management system of the disclosed systems and methods. It will be understood with benefit of this disclosure that classification methodology may be selected to fit the needs or characteristics of a particular network configuration. For example, outgoing packet classification as described above may be particularly desirable in the case of a network having limited core resources. On the other hand, outgoing packet classification may not be as desirable in the case of network having substantially unlimited core resources.

20

Returning now to FIG. 8, once objectives and system configuration have been defined in steps 1210 and 1220, an information management system may be assembled/manufactured according to the system configuration, purchased and installed as shown in step 1230 of FIG. 8. As previously described, a system may be installed in an HSP facility to provide differentiated business services for one or more tenants.

25

After an information system has been purchased and installed in step 1230, provisioning of system service parameters may be made in step 1240. Examples of such parameters include, but are not limited to, aggregate bandwidth ceiling, internal and/or external service level agreement ("SLA") policies (e.g., policies for treatment of particular information requests based on individual request and/or individual subscriber, class of request and/or class of subscriber, including or based on QoS, CoS and/or other class/service identification parameters associated therewith, *etc.*), admission control policy, information metering policy, classes per tenant, system resource allocation (e.g., bandwidth, processing

30

and/or storage resource allocation per tenant and/or class for a number of tenants and/or number of classes, *etc.*), *etc.*

Any parameter or combination of parameters suitable for partitioning system capacity, system use, system access, *etc.* in the creation and implementation of SLA policies may be considered. In this regard, the decision of which parameter(s) is/are most appropriate depends upon the business model selected by the host utilizing the system or platform, as well as the type of information manipulation function/s or applications (*e.g.*, streaming data delivery, HTTP serving, serving small video clips, web caching, database engines, application serving, *etc.*) that are contemplated for the system.

Examples of capacity parameters that may be employed in streaming data delivery scenarios include, but are not limited to delivered bandwidth, number of simultaneous N kbit streams, *etc.* Although delivered Mbit/s is also a possible parameter upon which to provision and bill non-streaming data applications, an alternate parameter for such applications may be to guarantee a number (N) of simultaneous connections, a number (N) of HTTP pages per second, a number (N) of simultaneous video clips, *etc.* In yet another example, a network attached storage ("NAS") solution may be ported to an information management system platform. In such a case, files may be delivered by NFS or CIFS, with SLA policies supplied either in terms of delivered bandwidth or file operations per second. It will be understood that the forgoing examples are exemplary and provided to illustrate the wide variety of applications, parameters and combinations thereof under which the disclosed systems and methods may be advantageously employed.

Referring to FIG. 8 in more detail, a description of exemplary system service parameters that may be defined and provisioned in step 1240 follows. System bandwidth ceiling may be provisioned at step 1240, and may represent a desired bandwidth ceiling defined by a Tenant or HSP that is below the actual system bandwidth ceiling capability. For example, a system may be capable of supporting a maximum bandwidth of from 335 Mbps (20 Kbps x 16,800 connections) to 800 Mbps (1 Mbps x 800 connections), but the Tenant or HSP may elect to place a bandwidth ceiling underneath these maximums.

SLA policies that may be created at step 1240 may be based on any parameter or combination of parameters suitable, for example, for the creation of a useful business model

for ISP / enterprise. Examples of SLA policies include, but are not limited to, class/service identification parameters such as CoS, QoS, combinations thereof, *etc.* A combination or sum of CoS and QoS may be used to define an SLA per class or flow (subscriber) within a system. Thus, in one embodiment, policy options may be stored in the system, and acted upon relative
5 to state information within the system architecture, such as information on resource availability and/or capability. Examples of other SLA policies that may that may be created in step 1240 include, but are not limited to, protocols for receipt, adherence and acknowledgment of requests for information such as content. For example, a content
10 delivery system may be configured to receive an SLA request from another network element (*e.g.*, including, for example, CoS and QoS requirements), and to respond back to the external entity with available service alternatives based on the available system resources and the SLA requirements of the request. The system may then be configured to receive explicit selection of alternative from the external entity, and to take action on the connection request based thereon.

15

SLA policies may be internally maintained (*e.g.*, database policy maintained within an information management system), may be externally maintained (*e.g.*, maintained on external network-connected user policy server, content policy server, *etc.*), or may be a combination thereof. Where external SLA information is employed or accessed by one or more
20 processing engines of an information management system, suitable protocols may be provided to allow communication and information transfer between the system and external components that maintain the SLA information.

SLA policies may be defined and provisioned in a variety of ways, and may be based
25 on CoS and QoS parameters that may be observed under a variety of congestion states. For example, both single class-based and multiple class-based SLAs (*e.g.*, three SLAs per class, *etc.*) are possible. Alternatively, an SLA may be defined and provisioned on a per-subscriber or per-connection basis. Furthermore, SLA policy definition and adherence management may be applied to subscribers or content, for example, in a manner that enables a content
30 owner to force a particular SLA policy to all sessions/flows requesting access to a particular piece of content or other information.

SLA policies may also be implemented to distinguish different CoS's based on a variety of different basis besides based on content (*e.g.*, content-aware service level

agreements). For example, in the case of platform serving applications, the CoS may be based upon application. For a platform serving HTTP as multiple hosts, the CoS may be based upon host. NAS applications may also be based easily on content, or upon host (volume) in the case of one platform serving many volumes. Other CoS basis may include
5 any other characteristic or combination of characteristics suitable for association with CoS, *e.g.*, time of day of request, *etc.*

Further, it is also possible to direct a system or platform to create classes based on subscriber. For example, a system login may be required, and a user directed to a given URL
10 reflective of the class to which the user belongs (*e.g.*, gold, silver, bronze, *etc.*). In such an implementation, the login process may be used to determine which class to which the user belongs, and the user then directed to a different URL based thereon. It is possible that the different URL's may all in fact link ultimately to the same content, with the information management system configured to support mapping the different URL's to different service
15 levels.

In yet other examples, more simplistic CoS schemes may be employed, for example, defining CoSs through the use of access control lists based on IP address (*e.g.*, ISP service log-ins, client side metadata information such as cookies, *etc.*), . This may be done manually,
20 or may be done using an automated tool. Alternatively, a service class may be created based on other factors such as domain name, the presence of cookies, *etc.* Further, policies may be created that map priority of incoming requests based on TOS bits to a class of service for the outbound response. Similarly, other networking methods may be used as a basis for CoS distinction, including MPLS, VLAN's, 802.1P/Q, *etc.* Thus, it will be understood that the
25 forgoing examples are exemplary only, and that SLAs may be implemented by defining CoSs based on a wide variety of different parameters and combinations thereof, including parameters that are content-based, user-based, application-based, request-based, *etc.*

In one exemplary embodiment, a number n of single Tenant per system classes of
30 service (CoS) may be defined and provisioned at step 1240 (*e.g.*, where n = from about 1 to about 32). In this regard, a single CoS may be considered an aggregate amount of bandwidth to be allocated to a number of connections when congestion dictates that bandwidth and system resource allocation decisions must be made. For example, a single CoS may be an aggregate bandwidth allocated to a number of connections m , *e.g.*, where m = from about 1 to
35 about 16,800. QoS may be considered a packet loss/latency provision that may, for example,

be assigned or provisioned on a per subscriber or per CoS basis, either alone or in combination with other QoS policies, as will be described in more detail below. For content delivery embodiments, characteristics of QoS policy may also be selected based on type of content (*e.g.*, minimum loss/latency policy for non-continuous content delivery, zero
5 loss/latency policy for continuous content delivery, *etc.*).

Policies such as per flow even egress bandwidth consumption (traffic shaping) may be defined and provisioned in step 1240, for example, for each CoS according to one or more possible network class types: Three specific examples of such possible class types are as
10 follows. 1) Sustained rate (bps) provisioned to be equal to peak rate, *i.e.*, so that available bandwidth is not oversubscribed within the CoS so that packets do not see any buffer delay. This may be described as being analogous to a continuous bit rate (“CBR”) connection. 2) Sustained rate (bps) allocated below its peak rate and oversubscribed within the CoS, *i.e.*, bandwidth is allocated statistically. This may be described as being analogous to a variable
15 bit rate (“VBR”) connection. In such a VBR embodiment, over-subscription may be controlled through the review of sustained and peak rate provisioning for individual connections, as well as the system aggregate of sustained and peak rate within the class. 3) No provisioned sustained or peak bandwidth per connection where class aggregate bandwidth is the only parameter provisioned and controlled, *i.e.*, any number of connections, up to the
20 maximum number set for a given class, are allowed to connect but must share the aggregate bandwidth without sustained or peak protection from other connections within the same class. This may be described as being analogous to a “best effort” class connection. It will be understood that the possible class types described above are exemplary only, and that other class types, as well as combinations of two or more class types may be defined and
25 provisioned as desired.

In another exemplary embodiment, bandwidth allocation, *e.g.*, maximum and/or minimum bandwidth per CoS, may be defined and provisioned in step 1240. In this regard, maximum bandwidth per CoS may be described as an aggregate policy defined per CoS for
30 class behavior control in the event of overall system bandwidth congestion. Such a parameter may be employed to provide a control mechanism for connection admission control (“CAC”), and may be used in the implementation of a policy that enables CBR-type classes to always remain protected, regardless of over-subscription by VBR-type and/or best effort-type classes. For example, a maximum bandwidth ceiling per CoS may be defined and

provisioned to have a value ranging from about 0 Mbps up to about 800 Mbps in increments of about 25 Mbps. In such an embodiment, VBR-type classes may also be protected if desired, permitting them to dip into bandwidth allocated for best effort-type classes, either freely or to a defined limit.

5

Minimum bandwidth per CoS may be described as an aggregate policy per CoS for class behavior control in the event of overall system bandwidth congestion. Such a parameter may also be employed to provide a control mechanism for CAC decisions, and may be used in the implementation of a policy that enables CBR-type and/or VBR-type classes to borrow
10 bandwidth from a best effort-type class down to a floor value. For example, a floor or minimum bandwidth value for a VBR-type or for a best effort-type class may be defined and provisioned to have a value ranging from about 0 Mbps up to 800 Mbps in increments of about 25 Mbps.

15 It will be understood that the above-described embodiments of maximum and minimum bandwidth per CoS are exemplary only, and that values, definition and/or implementation of such parameters may vary, for example, according to needs of an individual system or application, as well as according to identity of actual per flow egress bandwidth CoS parameters employed in a given system configuration. For example an
20 adjustable bandwidth capacity policy may be implemented allowing VBR-type classes to dip into bandwidth allocated for best effort-type classes either freely or to a defined limit. Other examples of bandwidth allocation-based CoS policies that may be implemented may be found in Examples 1-3 disclosed herein.

25 As previously mentioned, a single QoS or combination of QoS policies may be defined and provisioned on a per CoS, or on a per subscriber basis. For example, when a single QoS policy is provisioned per CoS, end subscribers who "pay" for, or who are otherwise assigned to a particular CoS are treated equally within that class when the system is in a congested state, and are only differentiated within the class by their particular
30 sustained/peak subscription. When multiple QoS policies are provisioned per CoS, end subscribers who "pay" for, or who are otherwise assigned to a certain class are differentiated according to their particular sustained/peak subscription and according to their assigned QoS. When a unique QoS policy is defined and provisioned per subscriber, additional service differentiation flexibility may be achieved. In one exemplary embodiment, QoS policies may

be applicable for CBR-type and/or VBR-type classes whether provisioned and defined on a per CoS or on a per QoS basis. It will be understood that the embodiments described herein are exemplary only and that CoS and/or QoS policies as described herein may be defined and provisioned in both single tenant per system and multi-tenant per system environments.

5

Further possible at step 1240 is the definition and provisioning of CAC policies per CoS, thus enabling a tenant or HSP to define policies for marginal connection requests during periods of system congestion. In this regard, possible policy alternatives include acceptance or rejection of a connection within a particular requested class. For example, a particular request may be accepted within a class up to a sustained bandwidth ceiling limitation for that class. As previously described, sustained bandwidth allocation may be equal to peak bandwidth allocated for a CBR-type class. For a VBR-type class, sustained bandwidth allocation may be less than allocated peak bandwidth and may be defined as a percentage of total bandwidth allocated. In the event the sustained bandwidth limitation has been exceeded, one or more different CAC policies may be implemented. For example, a connection may be rejected altogether, or may be rejected only within the requested class, but offered a lower class of service. Alternatively, such a connection may be accepted and other active connections allowed to service degrade (*e.g.*, unspecified bit rate "UBR", *etc.*). As described elsewhere herein, resource state information (*e.g.*, resource availability, capability, *etc.*) may be considered in the decision whether to accept or reject particular requests for information, such as particular subscriber requests for content. Resources may also be re-allocated or exchanged as desired to support particular requests, *e.g.*, borrowed from lower class to support higher class request, stolen from lower class to support higher class request, *etc.* Alternatively, requests may be redirected to alternative systems or nodes.

25

Summarizing with respect to step 1240, priority-indicative class/service identification parameters may be assigned to indicate the priority of service that a client on an external network is to receive, and a system may be provided with policies in step 1240 to prioritize and manage incoming and/or outgoing data and communication traffic flow through the system based on the characteristics of the class/service identification parameters associated therewith. Examples of such policies include, but are not limited to, policies capable of directing priority of system information retrieval from storage to satisfy a particular request having a class/service identification parameter relative to other pending requests for information, policies associating maximum time frame values for delivery of content based

30

on class/service identification parameters associated with a particular request, and disposal of such a request based on the availability of system resources and the characteristics of the particular class/service identification parameters associated with the request.

5 Further, admission control policies may be provisioned in step 1240 as previously described to consider, for example, the above-described class/service identification parameters, separate admission control policy priority parameters associated with particular information requests, current resource availability of the system, and/or may be implemented to consider one or more inherent characteristics associated with individual requests (*e.g.*, type
10 of information requested, resources required to satisfy a particular information request, identity of information requestor, *etc.*).

In one embodiment, an optional provisioning utility may be provided that may be employed to provide guidance as to the provisioning of a system for various forms of service
15 level support. For example, a host may initially create SLA policies in step 1240 using the optional provisioning tool which identifies provisioning issues during the process. In such an implementation, the provisioning tool may be provided to inform the host if policies have been selected that conflict, that exceed the capacity of the system platform as currently configured, *etc.*. For example, a host may be defining policies based on bandwidth
20 allocation, but fail to recognize that the system storage elements lack the capacity to handle the guaranteed rates. The optional provisioning utility may inform the host of the conflict or other provisioning issue. Further, the utility may be configured to provide suggestions to resolve the issue. For example, under the above scenario the utility may suggest adding more mirrors, adding another FC loop, *etc.* In addition, a provisioning utility may be further
25 configured to function in real time, for example, to assist and guide a host in making changes in service level provisioning after a system is placed in operation. Such real time provisioning may include optimization of SLA policies based on actual system performance and/or usage characteristics, changes to SLA policies as otherwise desired by user and/or host, *etc.* Specific examples include, but are not limited to, configuration of service quality
30 per subscriber, class, tenant, box, *etc.*; decisions to allow over-provisioning; decisions to allow over-provisioning in combination with re-direction of new requests, *etc.* In yet a further embodiment, such a provisioning utility may be adapted to analyze and provide suggested changes to service level provisioning based on actual system performance.

Step 1250 of FIG. 8 illustrates how system performance parameters related to information management, such as content delivery, may be differentially monitored. As indicated, monitoring may include both real time and historical tracking of system performance. System performance parameters that may be so monitored or tracked include, but are not limited to, resource availability and/or usage, adherence to provisioned SLA policies, content usage patterns, time of day access patterns, *etc.* As will be further described, such parameters may be monitored on the basis of the characteristics of a particular hardware/software system configuration, characteristics of an individual session, characteristics of a particular class, characteristics of a particular subscriber, characteristics of a particular tenant, subsystem or system performance, individual resource consumption, combinations thereof, *etc.* For example, service monitoring step 1250 may be performed on a system basis (*e.g.*, single box/chassis configuration, data center configuration, distributed cluster configuration, *etc.*), performed on a per tenant basis (*e.g.*, in the case of multiple tenants per system), performed on a per class basis (*e.g.*, in the case of multiple classes per tenant), performed on a per subscriber basis (*e.g.*, in the case of multiple subscribers per class), or a combination thereof. Thus, in one embodiment, service monitoring may be performed in a manner that considers each of the forgoing levels (*i.e.*, service monitoring for a particular subscriber of particular class of a particular tenant of a particular system).

Adherence to SLA policies may be monitored for an individual session or flow in real time and/or on a historical basis. In one exemplary embodiment, SLA adherence may be monitored or tracked by measuring packet throughput relative to sustained and peak rates per connection. For example, throughput statistics may be captured in specified time intervals (*e.g.*, five-minute increments). In another example, behavior of a particular class relative to aggregate assigned sustained and peak bandwidth allocation may be monitored or tracked in real time, or may be monitored or tracked over a period of time (*e.g.*, ranging from one hour to one day in one hour increments). In yet another example, behavior of an individual subsystem or an entire system relative to aggregate assigned sustained and peak bandwidth allocation may be monitored or tracked in real time, or may be monitored or tracked over a period of time (*e.g.*, ranging from one hour to one day in one hour increments).

It will be understood that the forgoing examples of adherence monitoring are exemplary only, and that a variety of other parameters and combinations of parameters may be monitored or tracked in step 1250 of FIG. 8. Furthermore, it will be understood that

monitored parameters may be displayed or otherwise communicated or recorded in any suitable manner. For example, current bandwidth consumption may be monitored in real time and presented, for example, via graphical user interface ("GUI"), data file, external report, or any other suitable means.

5

Also illustrated in FIG. 8 is information processing management step 1260, which may include managing disposition and/or prioritization of information manipulation tasks, such as any those of those information manipulation tasks described elsewhere herein. In this regard, information processing management step 1260 may involve system, inter-system and/or subsystem management of tasks including, but not limited to, admission control, resource allocation, queue prioritization, request transfer, *etc.* Furthermore, information manipulation tasks may be managed based on class/service identification parameters associated with particular information and/or requests for the same including, but not limited to, SLA policies or CoS/QoS parameters that may be defined and provisioned, for example, as described in relation to step 1240. As described elsewhere herein, such parameters may be defined and provisioned based on virtually any characteristic or combinations of characteristic associated with a particular information manipulation task including, but not limited to, identity or class of user or request, type of request, resource requirement associated with a particular request, *etc.*

10
15
20

As illustrated in FIG. 8, information processing management step 1260 may optionally utilize performance monitoring information obtained in step 1250, for example, to help make real time information processing management decisions (*e.g.*, based on subsystem, resource, and/or overall system behavior or usage), to adjust processing management behavior based on real time or historical monitored service levels (*e.g.*, to bring service level into adherence with SLA policy), *etc.*

25

In service reporting step 1270, a wide variety of performance and/or resource usage information may be collected and reported or otherwise communicated for the use of HSP, Tenants, Subscribers, *etc.* Such information may be utilized, for example, for purposes related to billing, demonstrating SLA policy adherence, system performance optimization, *etc.* and may be reported via GUI, data file, external report, or using any other suitable means (*e.g.*, reports viewable through in-system WEB-based GUI or through external Report Writer/Viewer utility). Information that may be reported in step 1270 includes virtually any

30

type of information related to operating or usage characteristics of an information management system, its subsystems and/or its resources, as well as information related to processing of individual requests or classes of requests, such as application and/or SLA performance.

5

Reporting functions possible in step 1270 include, but are not limited to, generation of any type of billing report based at least in part on collected performance and/or resource usage information, from generation of intermediate level reports (*e.g.*, flat file reports, *etc.*) that third party entities may use to convert to desired billing format, to generation of finalized
10 billing reports that may be forwarded directly to customers. Also possible are third party agents or client devices configured to receive billing information from the disclosed systems and configured to convert the information into desired format for passing onto a billing server. Such a scheme is also possible in which the disclosed systems are configured to output the billing information in desired format for transmittal to a billing server, without the
15 need for a third party client.

In one example, service configuration information may be reported, and may include all configured attributes such as CoSs and their parameters, QoSs and their parameters, individual subscriber SLAs, system resource consumption, *etc.* System performance
20 information may also be reported and may include, for example, periodic (*e.g.*, hourly, daily, monthly, *etc.*) totals of system resource utilization metrics. Application or SLA performance data may also be reported and may include information related to SLA activity, such as packets transmitted, packets dropped, latency statistics, percentage of time at or below sustained level, percentage of time above sustained and at or below peak level, *etc.* In this
25 regard, application or SLA performance data may also be reported on a periodic basis (*e.g.*, hourly, daily, monthly totals, *etc.*). SLA performance data may also be reported, for example, as aggregate performance statistics for each QoS, CoS and system as whole.

Types of billing information that may be reported in step 1270 includes, but is not
30 limited to, any type of information related to consumption or use of one or more system resources. In this regard, billing information may be generated on any desired detail level, for example, anywhere from a per-subscriber, per-request or per transaction basis to a per-class or per-tenant basis. Billing information may also be generated based on any desired fee basis, *e.g.*, fixed per use basis, relative resource consumption basis, percentage-service

guarantee basis, time of day basis, SLA conformance basis, performance level basis, combinations thereof, *etc.* Advantageously, billing basis may be static and/or dynamic as described further herein.

5 Examples of static resource consumption based billing include both application level billing information and system resource level billing information. Specific examples include, but are not limited to, static billing parameters such as fixed or set fees for processing cycles consumed per any one or more of subscriber/class/tenant/system, storage blocks retrieved per any one or more of subscriber/class/tenant/ system, bandwidth consumed per any one or more
10 of subscriber/class/tenant/system, combinations thereof, *etc.* Advantageously, resource consumption based billing is possible from any information source location (*e.g.*, content delivery node location, application serving node location, *etc.*) using the disclosed systems and methods, be it a origin or edge storage node, origin or edge application serving node, edge caching or content replication node, *etc.*

15

 Examples of dynamic billing basis include, but are not limited to, SLA conformance basis billing such as standard rate applied for actual performance that meets SLA performance guarantee with reduced billing rate applied for failure to meet SLA performance guarantee, sliding scale schedule providing reductions in billing rate related or proportional to
20 the difference between actual performance and SLA performance guarantee, sliding scale schedule providing reductions in billing rate related or proportional to the amount of time actual performance fails to meet SLA performance guarantee, combinations thereof, *etc.* Other examples of dynamic billing basis include performance level basis billing, such as sliding scale schedule providing multiple billing rate tiers that are implicated based on actual
25 performance, *e.g.*, higher rates applied for times of higher system performance and vice-versa.

 Furthermore, SLA performance information may be used as a billing basis or used to generate a fee adjustment factor for billing purposes. As is the case for other types of
30 information, information necessary for generating billing information and billing information itself, may be reported on a periodic basis (*e.g.*, hourly, daily, monthly totals, *etc.*) if so desired.

In one embodiment, standard bandwidth information may be reported as billing data and may reflect, for example, allocated sustained and peak bandwidth per subscriber, percentage of time at or below sustained bandwidth level, percentage of time above sustained bandwidth level and at or below peak bandwidth level, *etc.* In another embodiment, content usage information may be tracked and reported including, but not limited to, information on identity and/or disposition of content requests. Specific examples of such information includes, for example, record of content requests honored/rejected, record of content requests by subscriber, content request start time and content request fulfillment finish time, *etc.*

10 Among the many advantages offered by the differentiated service methodology of the embodiment illustrated in FIG. 8 is the capability of providing value-added and flexible SLA policies and “no penalty” service management capabilities that may make possible, among other things, competitive service differentiation and enhanced revenue generation. As used herein, “no penalty” is used to describe a capability (*e.g.*, differentiated service infrastructure capability) that may be offered in conjunction with basic information management functions (*e.g.*, content delivery, service delivery) with little or substantially no increase in required application/subsystem processing time relative to processing time required to perform the basic information management function alone. Just a few examples of specific flexible SLA policies that may be so provided include, but are not limited to, guaranteed system and/or subscriber capacity support, QoS assurance, CoS, adaptive CoS, *etc.* Examples of real time “no penalty” service management capabilities include, but are not limited to, configuration, capacity planning, system and application performance monitoring, billing, usage tracking, *etc.*

25 In one embodiment, these advantageous characteristics are made possible by employing system-aware and/or subsystem-aware application program interfaces (“APIs”), so that state and load knowledge may be monitored on a system and/or subsystem basis and application decisions made with real time, intimate knowledge concerning system and/or subsystem resources, for example, in a deterministic manner as described elsewhere herein.

30 In this regard, “no penalty” state and load management may be made possible by virtue of API communication that does not substantially consume throughput resources, and may be further enhanced by conveyance IPC communication protocol that supports prioritized I/O operations (*i.e.*, so that higher priority traffic will be allowed to flow in times of congestion) and overcomes weaknesses of message-bus architectures. Furthermore, features such as

application offloading, flow control, and rate adaptation are enhanced by the true multi-tasking capability of the distributively interconnected asymmetrical multi-processor architectures described elsewhere herein. Among other things, these extensible and flexible architectures make possible optimized application performance including allowing application-aware scalability and intelligent performance optimization. Other advantages that may be realized in particular implementations of systems with these architectures include, but are not limited to, reduced space and power requirements as compared to traditional equipment, intelligent application ports, fast and simple service activation, powerful service integration, *etc.*

10

As previously described, differentiated business services, including those particular examples described herein, may be advantageously provided or delivered in one embodiment at or near an information source (*e.g.*, at a content source or origin serving point or node, or at one or more nodes between a content source endpoint and a network core) using system embodiments described herein (*e.g.*, FIGS. 1A or 2), or using any other suitable system architecture or configuration. In one embodiment, a network core may be the public Internet and an associated information source may be, for example, a capacity-constrained content source such as storage network, storage virtualization node, content server, content delivery data center, edge content delivery node, or similar node in communication with the network core. In this embodiment, differentiated business services may be provided to allocate resources and/or costs at the content source and/or at a point or node anywhere between the content source and the network core, even in those cases where the core and last mile of the network provide relatively inexpensive and unlimited bandwidth and other resources for content delivery. Thus, a method of differentiating business services outside of a network core, and/or at a location upstream of the core is advantageously provided herein. The ability to differentiate business services under such circumstances provides a method for allocating resources and enhancing revenue generation that is not available using conventional network systems and methods.

30

Although the delivery of differentiated business services may be described herein in relation to exemplary content delivery source embodiments, the practice of the disclosed methods and systems is not limited to content delivery sources, but may include any other type of suitable information sources, information management systems/nodes, or combinations thereof, for example, such as application processing sources or systems. For

example, the description of content delivery price models and content delivery quality models is exemplary only, and it will be understood that the same principals may be employed in other information management embodiments (*e.g.*, application processing, *etc.*) as information management price models, information management quality models, and combinations thereof. Further, the disclosed systems and method may be practiced with information sources that include, for example, one or more network –distributed processing engines in an embodiment such as that illustrated in FIG. 9D, for example. Such network-distributed information sources may also be described as being outside the network core.

10 In one differentiated content delivery embodiment, the disclosed differentiated business services may be implemented to provide differentiated services at a content source based on one or more priority-indicative parameters associated with an individual subscriber, class of subscribers, individual request or class of request for content, *etc.* Such parameters include those types of parameters described elsewhere herein (*e.g.*, SLA policy, CoS, QoS, *etc.*), and may be user-selected, system-assigned, pre-determined by user or system, dynamically assigned or re-assigned based on system/network load, *etc.* Further, such parameters may be selected or assigned on a real time basis, for example, based on factors such as subscriber and/or host input, network and/or system characteristics and utilization, combinations thereof, *etc.* For example, a content subscriber may be associated with a particular SLA policy or CoS for all content requests (*e.g.*, gold, silver, bronze, *etc.*) in a manner as previously described, or may be allowed to make real time selection of desired SLA policy or CoS on a per-content request basis as described further herein. It will be understood that the forgoing description is exemplary only and that priority indicative parameters may be associated with content delivery or other information management/manipulation tasks in a variety of other ways.

30 In one exemplary implementation of user-selected differentiated content delivery, a user may be given the option of selecting content delivery (*e.g.*, a theatrical movie) via one of several pre-defined quality models, price/payment models, or combination thereof. In such an example, a high quality model (*e.g.*, gold) may represent delivery of the movie to the subscriber with sufficient stream rate and QoS to support a high quality and uninterrupted high definition television (“HDTV”) presentation without commercials or ad insertion, and may be provided to the subscriber using a highest price payment model. A medium quality model (*e.g.*, silver) may be provided using a medium price payment model and may represent

delivery of the movie to the subscriber with a lower stream rate and QoS, but without commercials or ad insertion. A lowest quality model (*e.g.*, bronze) may be provided using a lowest price payment model and may represent delivery of the movie to the subscriber with a lower stream rate and QoS, and with commercials or ad insertion. Quality/price models may
5 so implemented in a multitude of ways as desired to meet needs of particular information management environments, *e.g.*, business objectives, delivery configurations (*e.g.*, movie download delivery rather than streaming delivery), *etc.*

When user selectable quality/price models are offered, a subscriber may choose a
10 particular quality model based on the price level and viewing experience that is desired, *e.g.*, gold for a higher priced, high quality presentation of a first run movie, and bronze for a lower priced, lower quality presentation of a second run movie or obscure sporting event, *e.g.* such as will be played in the background while doing other things. Such a selection may be may be based on a pre-defined or beforehand choice for all content or for particular types or
15 categories of content delivered to the subscriber, or the subscriber may be given the option of choosing between delivery quality models on a real time or per-request basis. In one example, a GUI menu may be provided that allows a subscriber to first select or enter a description of desired content, and that then presents a number of quality/payment model options available for the selected content. The subscriber may then select the desired options
20 through the same GUI and proceed with delivery of content immediately or at the desired time/s. If desired, a subscriber may be given the opportunity to change or modify quality/price model selection after content delivery is initiated. Examples of categories of content that may be associated with different quality and/or price models include, but are not limited to, news shows, situation comedy shows, documentary films, first run movies,
25 popular or "hot" first run movies, old movies, general sports events, popular or "hot" sports events, *etc.*). Delivery of content at the selected quality/price model may be tracked and billed, for example, using system and method embodiments described elsewhere herein.

In another exemplary embodiment, multiple-tiered billing rates may be offered that
30 are based on information management resource consumption that is controllable or dictated by the user. For example, a user may be offered a first billing rate tier linked to, for example, maximum amount of resource consumption for non-streaming or non-continuous content (*e.g.*, maximum number of website hits/month, maximum number of HTTP files downloaded per month, maximum number of bytes of content streamed/month or downloaded/month from

NAS, maximum amount of processing time consumed/month, *etc.*). In such an embodiment, resource consumption below or up to a defined maximum consumption rate may be delivered for a given flat fee, or may be delivered at a given cost per unit of resource consumption. One or more additional billing rate tiers (*e.g.*, incremental flat fee, higher/lower cost per unit
5 of resource consumption, *etc.*) may be triggered when the user's resource consumption exceeds the first tier maximum resource consumption level. It will be understood that such an embodiment may be implemented with a number of different billing rate tiers, and that more than two such billing rate tiers may be provided.

10 In another exemplary embodiment for content delivery, content delivery options may be offered to subscribers that are customized or tailored based on network and/or system characteristics such as network infrastructure characteristics, system or subsystem resource availability, application mix and priority, combinations thereof, *etc.* For example, a subscriber's last mile network infrastructure may be first considered so that only those
15 content delivery options are offered that are suitable for delivery over the particular subscriber's last mile network infrastructure (*e.g.*, subscriber's local connection bandwidth, computer processor speed, bandwidth guarantee, *etc.*). Such infrastructure information may be ascertained or discovered in any manner suitable for gathering such information, for example, by querying the subscriber, querying the subscriber's equipment, querying metadata
20 (*e.g.*, cookies) contained on the subscriber's computer, xSP, policy server, *etc.*

In one example, this concept may be applied to the user selectable quality/price model embodiment described above. In such a case, a subscriber with relatively slow dial-up or ISDN network access, and/or having a relatively slow computer processor, may only be given
25 the option of a lowest quality model (*e.g.*, bronze) due to restricted maximum stream rate. In another example, a subscriber may be provided with a plurality of content delivery options and recommendations or assessments of, for example, those particular content delivery options that are most likely to be delivered to the individual subscriber at high performance levels given the particular subscriber's infrastructure, and those that are not likely to perform
30 well for the subscriber. In this case, the subscriber has the option of making an informed choice regarding content delivery option. The above approaches may be employed, for example, to increase the quality of a subscriber's viewing experience, and to reduce possible disappointment in the service level actually achieved.

In another example, customized or tailored content delivery options may be offered to subscribers based on characteristics associated with a particular request for content. In such an implementation, payment model and/or quality model may be host-assigned, system-assigned, *etc.* based on characteristics such as popularity of the requested content, 5 category/type of the requested content (*e.g.*, first run movie, documentary film, sports event, *etc.*), time of day the request is received (*e.g.*, peak or off-time), overall system resource utilization at the time of the requested content delivery, whether the request is for a future content delivery event (*e.g.*, allowing pre-allocation of necessary content delivery resources) or is a request for immediate content delivery (*e.g.*, requiring immediate allocation of content 10 delivery resources), combinations thereof, *etc.* For example, "hot" content such as highly popular first run movies and highly popular national sporting events that are the subject of frequent requests and kept in cache memory may be assigned a relatively lower price payment model based on the cost of delivery from cache or edge content delivery node, whereas more less popular or obscure content that must be retrieved from a storage source 15 such as disk storage may be assigned a higher price payment model to reflect higher costs associated with such retrieval. Alternatively, it may be desirable to assign payment models and/or quality models based on a supply and demand approach, *i.e.*, assigning higher price payment models to more popular content selections, and lower price payment models to less popular content selections. Whatever the desired approach, assignment of payment models 20 may advantageously be made in real time based on real time resource utilization, for example, using the differentiated service capabilities of the disclosed systems and methods.

By offering customized or tailored content delivery options as described above, content may be made available and delivered on price and quality terms that reflect value on 25 a per-request or per-content selection basis, reducing transaction costs and allowing, for example, content providers to recover costs required to maintain large libraries of content (*e.g.*, a large number of theatrical movies) for video on demand or other content delivery operations. The disclosed methods thus provide the ability to match price with value and to recover content storage/delivery costs. This ability may be advantageously implemented, for 30 example, to allow a large number of content selections to be profitably stored and made available to subscribers, including highly popular content selections as well as obscure or marginally popular content selections.

Utilizing the systems and methods disclosed herein makes possible the delivery of differentiated service and/or deterministic system behavior across a wide variety of application types and system configurations. Application types with which the disclosed differentiated service may be implemented include I/O intensive applications such as content
5 delivery applications, as well as non-content delivery applications.

Advantageously, the disclosed systems and methods may be configured in one embodiment to implement an information utility service management infrastructure that may be controlled by an information utility provider that provides network resources (*e.g.*,
10 bandwidth, processing, storage, *etc.*). Such an information utility provider may use the capabilities of the disclosed systems and methods to maintain and optimize delivery of such network resources to a variety of entities, and in a manner that is compatible with a variety of applications and network users. Thus, network resources may be made available to both
15 service providers and subscribers in a manner similar to other resources such as electricity or water, by an information utility provider that specializes in maintaining the network infrastructure and its shared resources only, without the need to worry or to become involved with, for example, application-level delivery details. Instead, such application-level details may be handled by customers of the utility (*e.g.*, application programmers, application
20 application developers, service providers, *etc.*) who specialize in the delivery and optimization of application services, content, *etc.* without the need to worry or to become involved with network infrastructure and network resource details, which are the responsibility of the utility provider.

The utility provider service management characteristics of the above-described
25 embodiment is made possible by the differentiated service capabilities of the disclosed systems and methods that advantageously allow differentiated service functions or tasks associated with the operation of such a utility (*e.g.*, provisioning, prioritization, monitoring, metering, billing, *etc.*) to be implemented at virtually all points in a network and in a low cost manner with the consumption of relatively little or substantially no extra processing time.
30 Thus, optimization of network infrastructure as well as applications that employ that infrastructure is greatly facilitated by allowing different entities (*e.g.*, infrastructure utility providers and application providers) to focus on their individual respective specialties.

In one exemplary content delivery embodiment, such a utility provider service management infrastructure may be made possible by implementing appropriate content delivery management business objectives using an information management system capable of delivering the disclosed differentiated information services and that may be configured and provisioned as disclosed herein, for example, to have a deterministic system architecture including a plurality of distributively interconnected processing engines that are assigned separate information manipulation tasks in an asymmetrical multi-processor configuration, and that may be deterministically enabled or controlled by a deterministic system BIOS and/or operating system.

10

EXAMPLES

The following hypothetical examples are illustrative and should not be construed as limiting the scope of the invention or claims thereof.

15

Examples 1-3 relate to an application that is delivering streams (e.g., video streams) of long duration. In the following examples, it is assumed that one subdirectory contains premium content (subdirectory /P), and that other subdirectories on the file system have non-premium content. An external authorization scheme is provided to direct premium customers to the /P directory, and to deny access to this directory for non-premium users. In the scenario of the following examples, all policies are based on two priorities, and do not take into account other parameters that may be considered such as delivered bandwidth, storage or FC utilization, utilization of other system resources, etc.

20

Example 1 -- Strict Bandwidth Allocation Policy

25

In this example, the admission control policy states that 100 Mbit/s is reserved for premium content. No additional bandwidth is to be used for premium content. There are multiple logical conditions that must be detected and responses considered. 1000 Mbit/s is the maximum deliverable bandwidth.

30

Under the admission control policy of this example, a premium stream will be admitted if the total premium bandwidth after admission will be less than or equal to 100 Mbit/s, but will be denied admission if the total premium bandwidth after admission will exceed 100 Mbit/s. A non-premium stream will be admitted if total non-premium bandwidth

after admission will be less than or equal to 900 Mbit/s, but will be denied admission if the total non-premium bandwidth after admission will be greater than 900 Mbit/s.

Example 2 – Additional Premium Bandwidth Allocation Policy

5

In this example, the admission control policy states that 100 Mbit/s is reserved for premium content, but premium content will be allowed to peak to 200 Mbit/s, where bandwidth allocation to premium content greater than 100 Mbit/s will generate incremental billable traffic. Bandwidth from non-premium content is decreased in support of any additional premium bandwidth admitted. Therefore, in this example the platform is not over-subscribed.

10

Under the admission control policy of this example, a premium stream will be admitted if the total premium bandwidth after admission will be less than or equal to 200 Mbit/s, but will be denied admission if the total premium bandwidth after admission will exceed 200 Mbit/s. A log event will occur if total premium bandwidth admitted is greater than 100 Mbit/s. A non-premium stream will be admitted if total non-premium bandwidth after admission will be less than or equal to 800 Mbit/s, but will be denied admission if the total non-premium bandwidth after admission will be greater than 800 Mbit/s.

20

Example 3 – Bandwidth Allocation Policy with Oversubscription

In this example, the admission control policy states that 100 Mbit/s is reserved for premium content. No additional bandwidth is to be used for premium content. Additional non-premium streams will be accepted if total bandwidth already being served is greater than 900 Mbit/s, and under the condition that premium users are NOT currently utilizing the full 100 Mbit/s. This scenario requires not only admission control behavior, but also requires system behavior modification should premium users request access when some of the 100 Mbit/s is being employed for non-premium streams.

30

Under the admission control policy of this example, a premium stream will be admitted if the total premium bandwidth after admission will be less than or equal to 100 Mbit/s, but will be denied admission if the total premium bandwidth after admission will exceed 100 Mbit/s. If the new total bandwidth after admission of a new premium stream will be greater than 1000 Mbit/s, non-premium streams will be degraded so that the total delivered bandwidth will be less than or equal to 1000 Mbit/s. A non-premium stream will be admitted

35

if total admitted bandwidth (*i.e.*, premium plus non-premium) after admission will be less than or equal to 1000 Mbit/s, but will be denied admission if the total admitted bandwidth after admission will be greater than 1000 Mbit/s.

5 To implement the policy of this example, bandwidth degradation of non-premium pool of streams may be accomplished, for example, by dropping one or more connections or typically more desirably, by degrading the rate at which one or more non-premium streams are delivered. In the latter case, once some of the premium bandwidth frees up, the non-premium streams may again be upgraded if so desired.

10

The three forms of policies represented in the foregoing examples may be used to handle an almost infinite number of possible configurations of an information management system or platform, such as a system of the type described in relation to the embodiment of FIG. 7. Furthermore, it will be understood that the principles utilized by these examples may be extended to cover a variety of information management scenarios including, but not limited to, for content delivery of multiple premium 'channels', for content delivery of multiple levels of premium channel, for metering bandwidth from a device serving files for multiple customers (*e.g.*, where the customers have different classes of service), *etc.* Furthermore, an information management system utilizing the methodology of the above examples may also include an optional utility as previously described herein that helps a HSP who is deploying the platform to choose an optimum configuration for maximizing revenue.

20

It will be understood with benefit of this disclosure that although specific exemplary embodiments of hardware and software have been described herein, other combinations of hardware and/or software may be employed to achieve one or more features of the disclosed systems and methods. For example, various and differing hardware platform configurations may be built to support one or more aspects of deterministic functionality described herein including, but not limited to other combinations of defined and monitored subsystems, as well as other types of distributive interconnection technologies to interface between components and subsystems for control and data flow. Furthermore, it will be understood that operating environment and application code may be modified as necessary to implement one or more aspects of the disclosed technology, and that the disclosed systems and methods may be implemented using other hardware models as well as in environments where the application and operating system code may be controlled.

35

Thus, while the invention may be adaptable to various modifications and alternative forms, specific embodiments have been shown by way of example and described herein. However, it should be understood that the invention is not intended to be limited to the particular forms disclosed. Rather, the invention is to cover all modifications, equivalents, and alternatives falling within the spirit and scope of the invention as defined by the appended claims. Moreover, the different aspects of the disclosed apparatus, systems and methods may be utilized in various combinations and/or independently. Thus the invention is not limited to only those combinations shown herein, but rather may include other combinations.

WHAT IS CLAIMED IS:

1. A system capable of providing differentiated service in a network environment, said system comprising at least one of:
5
 an information management system capable of providing session-aware differentiated service; or

 an information management system capable of providing differentiated service and
10 comprising a deterministic system architecture; or

 an information management system capable of providing differentiated service at a network endpoint of said network; or

15 a combination thereof.
2. The system of claim 1, said system comprising an information management system coupled to said network at a point outside a core of said network.
- 20 3. The system of claim 2, said system comprising a device that converges from an information source to said network.
4. The system of claim 2, said system comprising a content delivery system.
- 25 5. The system of claim 2, wherein said information management system comprises an application serving node.
6. The system of claim 2, said system comprising at least one at least one of a switch, router, server, load balancer, web-cache node, policy management node, traffic management
30 node, storage virtualization node, node between server and switch, storage networking node, application networking node, data communication networking node, content delivery management node, or a combination thereof.

7. The system of claim 2, said system comprising a storage virtualization node that comprises a cluster of two or more content delivery systems coupled together in a content delivery management configuration.

5 8. The system of claim 2, said system comprising at least one of a network endpoint information management node, an edge information management node, an intermediate traffic management node, an information management data center node, a processing engine node distributively interconnected with other processing engine nodes across said network, or a combination thereof.

10

9. The system of claim 8, said system comprising a network endpoint content delivery system, an edge content delivery system, an intermediate traffic management system coupled between a content source and said network, a content delivery data center system, a content delivery data processing engine, or a combination thereof.

15

10. The system of claim 9, said system comprising a network endpoint content delivery system.

11. The system of claim 2, wherein said differentiated service comprises at least one of
20 differentiated information service, differentiated business service, or a combination thereof.

12. The system of claim 2, said system being capable of providing one or more services or providing one or more packages of services to two or more different network entities in a manner that is differentiated between said two or more different network entities.

25

13. The system of claim 2, said system being capable of providing one or more services or providing one or more packages of services to two or more different network entities in a manner that vertically differentiates said services or packages of services between said two or more network entities.

30

14. The system of claim 2, said system being capable of providing respective services or packages of services associated with two or more different service provider network entities to one or more different network entities in a manner that horizontally differentiates each of

said services or packages of services based on the respective service provider associated with each of said services or packages of services.

15. The system of claim 1, wherein said system comprises an information management
5 system having a deterministic system architecture that comprises a plurality of distributively interconnected processing engines.

16. The system of claim 1, wherein said system comprises an information management
system capable of dynamic resource allocation or re-allocation.

10

17. The system of claim 2, said system comprising:

a deterministic system architecture;

15

an operating system in communication with said deterministic system architecture;

at least one application in communication with said operating system; and

a differentiated service infrastructure in communication with said operating system.

20

18. The system of claim 17, wherein said differentiated service comprises differentiated
information service.

19. The system of claim 17, wherein said differentiated service comprises differentiated
25 business service.

20. A method of providing differentiated service in a network environment, said method
comprising:

30 providing session-aware differentiated service using at least one information
management system; or

providing differentiated service using an information management system that
comprises a deterministic system architecture; or

providing differentiated service at a network endpoint of said network using an information management system; or

5 a combination thereof.

21. The method of claim 20, wherein said providing comprises providing said differentiated service using at least one information management system coupled to said network at a point outside a core of said network.

10

22. The method of claim 21, wherein said at least one information management system comprises a device that converges from an information source to said network.

23. The method of claim 21, wherein said at least one information management system
15 comprises an application serving node.

24. The method of claim 21, wherein said at least one information management system comprises a content delivery system.

20 25. The method of claim 21, wherein said at least one information management system comprises at least one of a switch, router, server, load balancer, web-cache node, policy management node, traffic management node, storage virtualization node, node between server and switch, storage networking node, application networking node, data communication networking node, content delivery management node, or a combination
25 thereof.

26. The method of claim 21, wherein said at least one information management system comprises a storage virtualization node comprising a cluster of two or more content delivery systems coupled together in a content delivery management configuration.

30

27. The method of claim 21, wherein said at least one information management system comprises at least one of a network endpoint information management node, an edge information management node, an intermediate traffic management node, an information

management data center node, a processing engine node distributively interconnected with other processing engine nodes across said network, or a combination thereof.

28. The method of claim 27, wherein said at least one information management system
5 comprises a network endpoint content delivery system, an edge content delivery system, an intermediate traffic management system coupled between a content source and said network, a content delivery data center system, a content delivery data processing engine, or a combination thereof.

10 29. The system of claim 28, said system comprising a network endpoint content delivery system.

30. The method of claim 21, wherein said differentiated service comprises at least one of differentiated information service, differentiated business service, or a combination thereof.

15

31. The method of claim 21, wherein said providing differentiated service comprises providing one or more services or providing one or more packages of services, to two or more different network entities in a manner that is differentiated between said two or more different network entities.

20

32. The method of claim 21, wherein said providing differentiated service comprises providing one or more services or providing one or more packages of services, to two or more different network entities in a manner that vertically differentiates said services or packages of services between said two or more network entities.

25

33. The method of claim 21, wherein said providing differentiated service comprises providing respective services or packages of services associated with two or more different service provider network entities to one or more different network entities in a manner that horizontally differentiates each of said services or packages of services based on the
30 respective service provider associated with each of said services or packages of services.

34. The method of claim 20, wherein said system comprises an information management system having a deterministic system architecture that comprises a plurality of distributively interconnected processing engines; and wherein said method comprises manipulating

information in a differentiated manner by assigning one or more tasks to one or more of said processing engines to cause said differentiated manipulation of information.

35. The system of claim 20 wherein said method further comprises dynamically
5 allocating or re-allocating system resources.

36. The method of claim 20, wherein said providing comprises providing said differentiated service using a system comprising:

10 a deterministic system architecture;

an operating system in communication with said deterministic system architecture;

at least one application in communication with said operating system; and

15

a differentiated service infrastructure in communication with said operating system.

37. The method of claim 36, wherein said differentiated service comprises differentiated information service.

20

38. The method of claim 36, wherein said differentiated service comprises differentiated information service.

39. A method of providing differentiated service in a network environment, said method
25 comprising providing said differentiated service from a network endpoint information management system.

40. The method of claim 39, wherein said network endpoint information management system is coupled to one or more intermediate or core nodes of a network.

30

41. The method of claim 39, wherein said network endpoint information management system is coupled to one or more core nodes of a network via one or more intermediate nodes

42. The method of claim 39, wherein said network endpoint information management system comprises a network endpoint content delivery system.

43. The method of claim 42, wherein said network endpoint information management system comprises a content source, and wherein said providing differentiated service comprises handling at least one of incoming or outgoing information traffic in a differentiated manner based on one or more parameters associated with said traffic, or a combination thereof.

44. The method of claim 43, wherein said providing differentiated service comprises at least one of:

reading incoming classification information associated with incoming data packets and handling said incoming data packets in a differentiated manner based on said incoming classification information associated with said data packets; or

tagging outgoing data packets with outgoing classification information readable by one or more of said intermediate or core nodes, said outgoing classification information being reflective of differentiated handling instructions for said outgoing data packets by one or more of said intermediate or core nodes; or

a combination thereof.

45. The method of claim 44, wherein said differentiated service comprises differentiated business service.

46. The method of claim 44, wherein said differentiated service comprises differentiated information service.

47. A method of providing differentiated service in a network environment, said method comprising providing said differentiated service from an information management data center node coupled to said network.

48. The method of claim 47, wherein said method further comprises providing differentiated business service on behalf of two or more tenant xSP's from said information management data center node.

5 49. The method of claim 47, wherein said information management data center node is coupled to one or more core nodes of said network without the presence of intervening intermediate nodes, and wherein said providing comprises providing said differentiated service directly to one or more core nodes of said network.

10 50. The method of claim 49, wherein said information management data center node comprises a content delivery data center system.

51. The method of claim 50, wherein said information management data center node comprises a content source, and wherein said providing differentiated service comprises
15 handling at least one of incoming or outgoing information traffic in a differentiated manner based on one or more parameters associated with said traffic, or a combination thereof.

52. The method of claim 51, wherein said providing differentiated service comprises at least one of:

20

reading incoming classification information associated with incoming data packets and handling said incoming data packets in a differentiated manner based on said incoming classification information associated with said data packets; or

25 tagging outgoing data packets with outgoing classification information readable by one or more of said intermediate or core nodes, said outgoing classification information being reflective of differentiated handling instructions for said outgoing data packets by one or more core nodes of said network; or

30 a combination thereof.

53. The method of claim 52, wherein said differentiated service comprises differentiated business service.

54. The method of claim 52, wherein said differentiated service comprises differentiated information service.
55. A method of providing differentiated service in a network environment, said method
5 comprising providing session-aware differentiated service from an intermediate traffic management node coupled to said network.
56. The method of claim 55, wherein said intermediate traffic management node is
10 coupled between a network endpoint information management system and one or more intermediate or core nodes of said network, and wherein said providing comprises providing said differentiated service directly to said one or more intermediate or core nodes of said network.
57. The method of claim 56, wherein said intermediate traffic management node is
15 present as a subsystem component of an intermediate node and is coupled to at least one core node of said network, and wherein said providing comprises providing said differentiated service directly to said at least one core node of said network
58. The method of claim 56, wherein said intermediate traffic management node is
20 coupled between a network endpoint content delivery system and said one or more intermediate or core nodes of said network.
59. The method of claim 58, wherein said providing differentiated service comprises
25 handling at least one of incoming or outgoing information traffic in a differentiated manner based on one or more parameters associated with said traffic, or a combination thereof.
60. The method of claim 59, wherein said differentiated service comprises at least one of
30 service level management, classification, or data logging of traffic between said network endpoint content delivery system and said one or more core nodes of said network, or a combination thereof.
61. The method of claim 60, wherein said differentiated service comprises at least one of making data traffic redirection decisions, classifying data packets, tracking data traffic, or a combination thereof.

62. The method of claim 61, wherein said providing differentiated service comprises at least one of:

5 reading incoming classification information associated with incoming data packets and handling said incoming data packets in a differentiated manner based on said incoming classification information associated with said data packets; or

10 tagging outgoing data packets with outgoing classification information readable by one or more of said intermediate or core nodes, said outgoing classification information being reflective of differentiated handling instructions for said outgoing data packets by one or more of said intermediate or core nodes; or

a combination thereof.

15

63. The method of claim 55, wherein said intermediate traffic management node comprises an information management system having a deterministic system architecture that comprises a plurality of distributively interconnected processing engines; and wherein said method comprises manipulating information in a differentiated manner by assigning one or more tasks to one or more of said processing engines to cause said differentiated manipulation of information.

25

64. The system of claim 55 wherein said method further comprises dynamically allocating or re-allocating system resources.

65. The method of claim 62, wherein said differentiated service comprises differentiated business service.

66. The method of claim 62, wherein said differentiated service comprises differentiated information service.

30

67. A method of providing differentiated service in a network environment, said method comprising providing session-aware differentiated service from an edge information management node coupled to said network.

68. The method of claim 67, wherein said edge information management node is coupled to one or more core nodes of said network without the presence of intervening intermediate nodes, and wherein said providing comprises providing said differentiated service directly to
5 one or more core nodes of said network.

69. The method of claim 68, wherein said edge information management node is coupled by a signal path to one or more other separate edge information management nodes in a clustered configuration.
10

70. The method of claim 69, wherein said signal path enables deterministic communication between said separate information management nodes, and wherein said providing differentiated service comprises managing the manipulation of information between said separate clustered information management nodes in a deterministic manner.
15

71. The method of claim 70, wherein said providing differentiated service further comprises receiving a request for information management from a user, and selecting one or more particular edge information management nodes to manage information in response to said request; wherein one or more edge information management nodes selected corresponds
20 to a node containing specific information requested by said user, corresponds to a node assigned to a particular SLA policy associated with said request or said user, corresponds to a node having sufficient available resources to manage information associated with said request, or a combination thereof.

25 72. The method of claim 71, wherein said one or more edge information management nodes comprise edge content delivery systems, and wherein said request for information management comprises a request for content delivery.

73. The method of claim 68, wherein said edge information management node comprises
30 an edge content delivery system.

74. The method of claim 69, wherein said edge content delivery system comprises a content source, and wherein said providing differentiated service comprises handling at least

one of incoming or outgoing information traffic in a differentiated manner based on one or more parameters associated with said traffic, or a combination thereof.

75. The method of claim 70, wherein said providing differentiated service comprises at least one of:

reading incoming classification information associated with incoming data packets and handling said incoming data packets in a differentiated manner based on said incoming classification information associated with said data packets; or

tagging outgoing data packets with outgoing classification information readable by one or more core nodes of said network, said outgoing classification information being reflective of differentiated handling instructions for said outgoing data packets by one or more of said core nodes; or

a combination thereof.

76. The method of claim 67, wherein said intermediate traffic management node comprises an information management system having a deterministic system architecture that comprises a plurality of distributively interconnected processing engines; and wherein said method comprises manipulating information in a differentiated manner by assigning one or more tasks to one or more of said processing engines to cause said differentiated manipulation of information.

77. The system of claim 67 wherein said method further comprises dynamically allocating or re-allocating system resources.

78. The method of claim 75, wherein said differentiated service comprises differentiated business service.

79. The method of claim 75, wherein said differentiated service comprises differentiated information service.

80. A method of providing differentiated service to a network core, comprising providing session-aware differentiated service using at least one information management node.

81. The method of claim 80, wherein said method further comprises providing said
5 differentiated service in a manner that is network transport independent.

82. The method of claim 80, wherein said providing differentiated service comprises differentiating data packets in a session-aware manner based on packet classification, said packet classification being representative of one or more policy-indicative parameters
10 associated with information management policy.

83. The method of claim 82, wherein said wherein said providing differentiated service comprises differentiating data packets by at least one of reading packet classifications of incoming packets to said information management node, tagging outgoing packets from said
15 information management node with packet classifications, or a combination thereof.

84. The method of claim 82, wherein said packet classification is based on a packet classification technology that is at least one of a layer two through layer seven packet classification technology.
20

85. The method of claim 83, wherein said information management node comprises at least one network processor, and wherein said method comprises reading packet classifications of incoming packets, or tagging said outgoing packets with packet classifications using said at least one network processor.
25

86. The method of claim 85, wherein said information management node comprises a network endpoint information management node, and wherein said method further comprises searching packets incoming to said information management node for labels representative of one or more policy-indicative parameters associated with information management policy,
30 and further comprises handling each said packet according to a policy associated with said one or more parameters.

87. The method of claim 85, wherein said information management node comprises a network endpoint information management node, and wherein said method further comprises

tagging outgoing packets from said network endpoint information management node with labels representative of one or more policy-indicative parameters associated with information management policy, said labels on each said outgoing packet band indicating how said packet should be differentially handled by one or more intermediate or core nodes of said network.

5

88. The method of claim 85, wherein said information management node comprises a network endpoint information management node, and wherein said method further comprises tagging outgoing packets from said network endpoint information management node with labels representative of one or more policy-indicative parameters associated with information management policy, said labels on each said outgoing packet band indicating how said packet should be differentially handled by one or more intermediate or core nodes of said network.

10

89. The method of claim 87, wherein said network endpoint information management node is configured to be application-aware, and wherein said method comprises tagging said outgoing packets with labels in a manner that achieves application aware packet classification.

15

90. The method of claim 85, wherein said information management node comprises an intermediate traffic management node coupled between an information source origin and said core of said network, and wherein said method further comprises searching packets incoming to said traffic management node for labels representative of one or more policy-indicative parameters associated with information management policy, and further comprises transferring each said packet to said information source origin for further handling according to said labels.

20

91. The method of claim 85, wherein said information management node comprises an intermediate traffic management node coupled between an information source origin and said core of said network, and wherein said method further comprises tagging outgoing packets from said network endpoint information management node with labels representative of one or more policy-indicative parameters associated with information management policy, and further comprising transferring each said packet to an intermediate node coupled between said traffic management node and said core of said network or directly to a core of said network for further handling according to said labels.

25

30

92. A method of managing information in a network connectable information management system, comprising at least one of:

5 manipulating information in a differentiated manner based at least in part on a status of at least one parameter associated with a request received from a network for said information manipulation; or

10 monitoring resource usage within said system in a differentiated manner; or a combination thereof.

93. The method of claim 92, wherein said network connectable information management comprises a deterministic system architecture.

15 94. The method of claim 93, wherein said information management system comprises a network endpoint system.

20 95. The method of claim 94, wherein said network endpoint system is a content delivery system.

96. The method of claim 93, wherein said system comprises an intermediate node system, and wherein one of said processing engines comprises a network processor.

25 97. The method of claim 96, wherein said intermediate node system is a network switch, network router, web cache node, traffic management node, edge serving device, or a combination thereof.

30 98. The method of claim 93, wherein said manipulating comprises manipulating said information in a manner differentiated relative to other requests received from said network for information manipulation.

99. The method of claim 98, wherein said manipulating comprises delivering content to said network in a manner differentiated relative to other requests received from said network for content delivery.

100. The method of claim 93, wherein said parameter comprises priority-indicative information associated with said request.

5 101. The method of claim 93, wherein said method comprises manipulating information in a differentiated manner; and further comprises reserving resources within said system that are required to manipulate said information, said reserving occurring prior to said manipulating.

10 102. The method of claim 101, wherein said system comprises a plurality of processing engines, each of said processing engines being assigned separate information manipulation tasks in an asymmetrical multi-processor configuration; and wherein said method comprises manipulating information in a differentiated manner by assigning one or more tasks to one or more of said processing engines to cause said differentiated manipulation of information.

15 103. The method of claim 93, wherein said method comprises monitoring resource usage within said system in a differentiated manner.

20 104. The method of claim 103, wherein said resource usage reflects resources required to manipulate information in response to a request received from said network for said information manipulation.

105. The method of claim 103, wherein said system comprises shared resources, and wherein said method comprises monitoring usage of said shared resources.

25 106. The method of claim 103, wherein said method further comprises generating billing information based on said monitored resource usage.

30 107. The method of claim 103, wherein said method further comprises using said monitored resource usage to determine or evaluate information manipulation performance.

108. The method of claim 103, wherein said method further comprises using said monitored resource usage to track at least one of system performance, application performance, or compliance with service level agreement policy terms.

109. The method of claim 103, wherein said system comprises a plurality of processing engines, each of said processing engines being assigned separate information manipulation tasks in an asymmetrical multi-processor configuration; and wherein said method comprises manipulating information in a differentiated manner by assigning one or more tasks to one or more of said processing engines based on said monitored resource usage to cause said differentiated manipulation of information.

110. The method of claim 93, wherein said system comprises a plurality of processing engines, each of said processing engines being assigned separate information manipulation tasks in an asymmetrical multi-processor configuration; and wherein said method comprises manipulating information in a differentiated manner by assigning one or more tasks to one or more of said processing engines based on said status of at least one parameter associated with a request received from a network for said information manipulation to cause said differentiated manipulation of information.

15

111. The method of claim 110, wherein said system further comprises a deterministic system BIOS, deterministic operating system, or combination thereof that is capable of effecting said assignment of said one or more tasks to one or more of said processing engines based on said status of at least one parameter.

20

112. The method of claim 110, wherein said assigning of one or more tasks to said one or more of said processing engines comprises making appropriate system calls to OS-extensions.

113. The method of 110, wherein the status of said at least one parameter associated with said request is indicative of a relative priority of said request; wherein said plurality of processing engines are interconnected in a distributed manner that supports prioritized I/O operations; and wherein said assigning comprises prioritizing the assignment of one or more tasks to one or more of said processing engines based on the relative priority of said status of said at least one parameter so that information traffic associated with requests having higher relative priority continues to flow relative to information traffic associated with requests having lower relative priority in times during which said interconnection between said processing engines is congested.

30

114. The method of claim 113, wherein said plurality of processing engines are interconnected with a switch fabric that supports prioritized I/O operations.

115. The method of claim 93, wherein said method comprises manipulating information in a differentiated manner by implementing the necessary system resource utilization and user priority information using system calls to OS-extensions.

116. The method of claim 93, wherein said system comprises a network endpoint system, and wherein said method comprises manipulating information in a differentiated manner by distinguishing between two or more different service class parameters associated with two or more respective information manipulation tasks.

117. The method of claim 116, wherein said manipulating information in a differentiated manner further comprises performing each of said two or more respective information manipulation tasks in a differentiated manner based upon identity of said two or more service class parameters.

118. The method of claim 116, wherein said manipulating information in a differentiated manner further comprises making one or more processing decisions regarding the performance of said two or more respective information manipulation tasks relative to each other.

119. The method of claims 118, wherein said one or more processing decisions comprises a decision related to admission control, resource allocation, queue prioritization, request transfer, or a combination thereof.

120. The method of claim 119, wherein said network endpoint system is a content delivery system, and wherein said two or more respective information manipulation tasks are associated with the fulfillment of two or more respective requests for content.

121. The method of claim 120, wherein said service class parameters each comprise at least one of a parameter based on content, a parameter based on application, a parameter based on user, or a combination thereof.

122. The method of claim 116, wherein said distinguishing between two or more different service class parameters comprises using one or more policies to direct the operational behavior of the network endpoint system.

5 123. The method of claim 122, further comprising using said one or more policies to associate each of said two or more service class parameters with a particular network class of service mechanism.

10 124. A system for providing differentiated service in an information management environment, comprising a deterministic system architecture, said system being capable of providing differentiated service.

125. The system of claim 124, further comprising:

15 an operating system in communication with said deterministic system architecture;

at least one application in communication with said operating system; and

20 a differentiated service infrastructure in communication with said operating system, said differentiated service infrastructure being capable of performing differentiated service tasks.

126. The system of claim 125, wherein said deterministic system architecture comprises a plurality of processing engines that are distributively interconnected.

25

127. The system of 126, wherein said processing engines are assigned separate information manipulation tasks in an asymmetrical multi-processor configuration.

30 128. The system of 127, wherein said deterministic system architecture further comprises deterministic system software in communication with said operating system and having state knowledge of resource utilization within said architecture, said deterministic system software being capable of deterministically controlling interaction between said distributively interconnected processing engines in response to communication received from said operating system.

129. The system of claim 128, wherein at least one of said processing engines comprises a monitoring agent capable of monitoring resource characteristics of said processing engine, and wherein said system architecture further comprises a system monitor in communication
5 with said monitoring agent that has system management capability.

130. The system of claim 125, wherein said system architecture is capable of supporting a discrete family of applications or multiple concurrent applications.

10 131. The system of claim 129, wherein said system architecture supports system calls to OS-extensions to determine characteristics of one or more resource utilization parameters associated with one or more of said processing engines.

132. The system of claim 125, wherein said system architecture supports system calls to
15 OS-extensions to determine characteristics of user priority information associated with information managed in said information management environment.

133. The system of claim 131, wherein said system architecture further supports system calls to OS-extensions to determine characteristics of user priority information associated
20 with information managed in said information management environment.

134. The system of claim 131, wherein said operating system comprises a conventional operating system, and wherein said at least one application is ported to said operating system through an application programming interface so that functions of said application are
25 executed in a manner that is unaware of asymmetric and deterministic capabilities of said system architecture.

135. The system of claim 131, wherein said at least one application is configured to intelligently handle system congestion by virtue of code included in said application that
30 utilizes calls into said operating system indicative of the relative priority of each connection or request, and that utilizes calls indicative of the availability of necessary resources in said system architecture to support information management capability.

136. The system of claim 131, wherein said operating system is capable of direct deterministic communication with said deterministic system architecture, and is further capable of implementing and managing system calls indicative of the relative priority of each connection or request, and that utilizes calls indicative of the availability of necessary
5 resources in said system architecture to support information management capability.

137. The system of claim 125, further comprising a deterministic system BIOS that provides a communication interface between said system architecture and said operating system.
10

138. The system of claim 131, further comprising a deterministic system BIOS that provides a communication interface between said system architecture and said operating system, said deterministic system BIOS capable of managing system calls made to processing engines of said system architecture from said at least one application.
15

139. The system of claim 138, wherein said deterministic system BIOS is capable of responding to application requests for resources with availability information, rerouting information, SLA choice information, or a combination thereof.

20 140. The system of claim 125, further comprising at least one application program interface that provides communication interface between said at least one application and said operating system.

141. The system of claim 140, wherein said application comprises at least one of an
25 internet application, network content delivery application, or a combination thereof.

142. The system of claim 125, wherein said differentiated service tasks comprise at least one of:

30 provisioning one or more system service parameters;

monitoring one or more system performance parameters related to information management in real time or on a historical basis;

managing performance of one or more information manipulation tasks related to said information management based on one or more class identification parameters associated with said information manipulation tasks and based on one or more provisioned system service parameters, one or more monitored system performance parameters, or a combination
5 thereof;

reporting information related to said monitored system performance parameters; or

a combination thereof.

10

143. The system of claim 142, wherein said differentiated service tasks comprise reporting information related to said monitored system performance to a physically remote located system or external entity for generation of billing data based thereon.

15 144. The system of claim 142, wherein said reported information comprises billing information.

145. The system of claim 144, wherein said billing information is related to consumption or use of one or more system resources.

20

146. The system of claim 125, wherein said operating system is configured in deterministic communication with system or subsystem components that are external to said system.

147. The system of claim 146, wherein said external system or subsystem components
25 comprise clustered arrangements of geographically dispersed systems, subsystems or components.

148. The system of claim 146, wherein said external system or subsystem components
30 comprise components not directly coupled to said system through a common distributed interconnect.

149. The system of claim 125, wherein said system comprises an information management node coupled to a network at a point outside a core of said network.

150. A method of providing differentiated service in an information management environment, comprising providing said differentiated service using at least one information management system that comprises a deterministic system architecture.

5 151. The method of claim 150, wherein said system further comprises:

an operating system in communication with said deterministic system architecture;

at least one application in communication with said operating system; and

10

a differentiated service infrastructure in communication with said operating system, said differentiated service infrastructure being capable of performing differentiated service tasks.

15 152. The method of claim 151, wherein said deterministic system architecture comprises a plurality of processing engines that are distributively interconnected and that are assigned separate information manipulation tasks in an asymmetrical multi-processor configuration; wherein said deterministic system architecture further comprises deterministic system software in communication with said operating system and having state knowledge of
20 resource utilization within said architecture; and wherein said method further comprises using said deterministic system software to deterministically control interaction between said distributively interconnected processing engines in response to communication received from said operating system.

25 153. The method of claim 152, wherein one or more of said processing engines comprises a monitoring agent; wherein said system architecture further comprises a system monitor in communication with said monitoring agent; and wherein said method further comprises monitoring resource characteristics of said processing engine with said system monitor, and performing system management with said system monitor.

30

154. The method of claim 153, wherein said method further comprises making system calls to OS-extensions to determine characteristics of one or more resource utilization parameters associated with one or more of said processing engines; and making calls to OS-extensions to

determine characteristics of user priority information associated with information managed in said information management environment.

155. The method of claim 154, wherein said method further comprises intelligently
5 handling system congestion using code included in said at least one application by utilizing calls into said operating system indicative of the relative priority of each connection or request; and by utilizing calls indicative of the availability of necessary resources in said system architecture to support information management.

10 156. The method of claim 154, wherein said operating system is capable of direct deterministic communication with said deterministic system architecture; and wherein said method further comprises using said operating system to implement and manage system calls indicative of the relative priority of each connection or request; and using said operating system to support information management by using calls indicative of the availability of
15 necessary resources in said system architecture.

157. The method of claim 151, wherein said system further comprises a deterministic system BIOS that provides a communication interface between said system architecture and said operating system; and wherein said method further comprises using said deterministic
20 system BIOS to manage system calls made to processing engines of said system architecture from said at least one application; and using said deterministic system BIOS to respond to application requests for resources with availability information, rerouting information, SLA choice information, or a combination thereof.

25 158. The method of claim 151, wherein said system further comprises at least one application program interface that provides communication interface between said at least one application and said operating system; and wherein said application comprises at least one of an internet application, network content delivery application, or a combination thereof.

30 159. The method of claim 151, wherein said differentiated service comprises at least one of:

provisioning one or more system service parameters;

monitoring one or more system performance parameters related to information management in real time or on a historical basis;

managing performance of one or more information manipulation tasks related to said
5 information management based on one or more class identification parameters associated with said information manipulation tasks and based on one or more provisioned system service parameters, one or more monitored system performance parameters, or a combination thereof;

10 reporting information related to said monitored system performance parameters; or
a combination thereof.

160. The method of claim 159, wherein said differentiated service tasks comprise reporting
15 information related to said monitored system performance to a physically remote located system or external entity for generation of billing data based thereon; said reported information comprising billing information related to consumption or use of one or more system resources.

20 161. The method of claim 151, wherein said operating system is configured in deterministic communication with system or subsystem components that are external to said system.

162. The system of claim 161, wherein said external system or subsystem components
25 comprise clustered arrangements of geographically dispersed systems, subsystems or components.

163. The system of claim 161, wherein said external system or subsystem components
30 comprise components not directly coupled to said system through a common distributed interconnect.

164. The system of claim 151, wherein said system comprises an information management node coupled to a network at a point outside a core of said network.

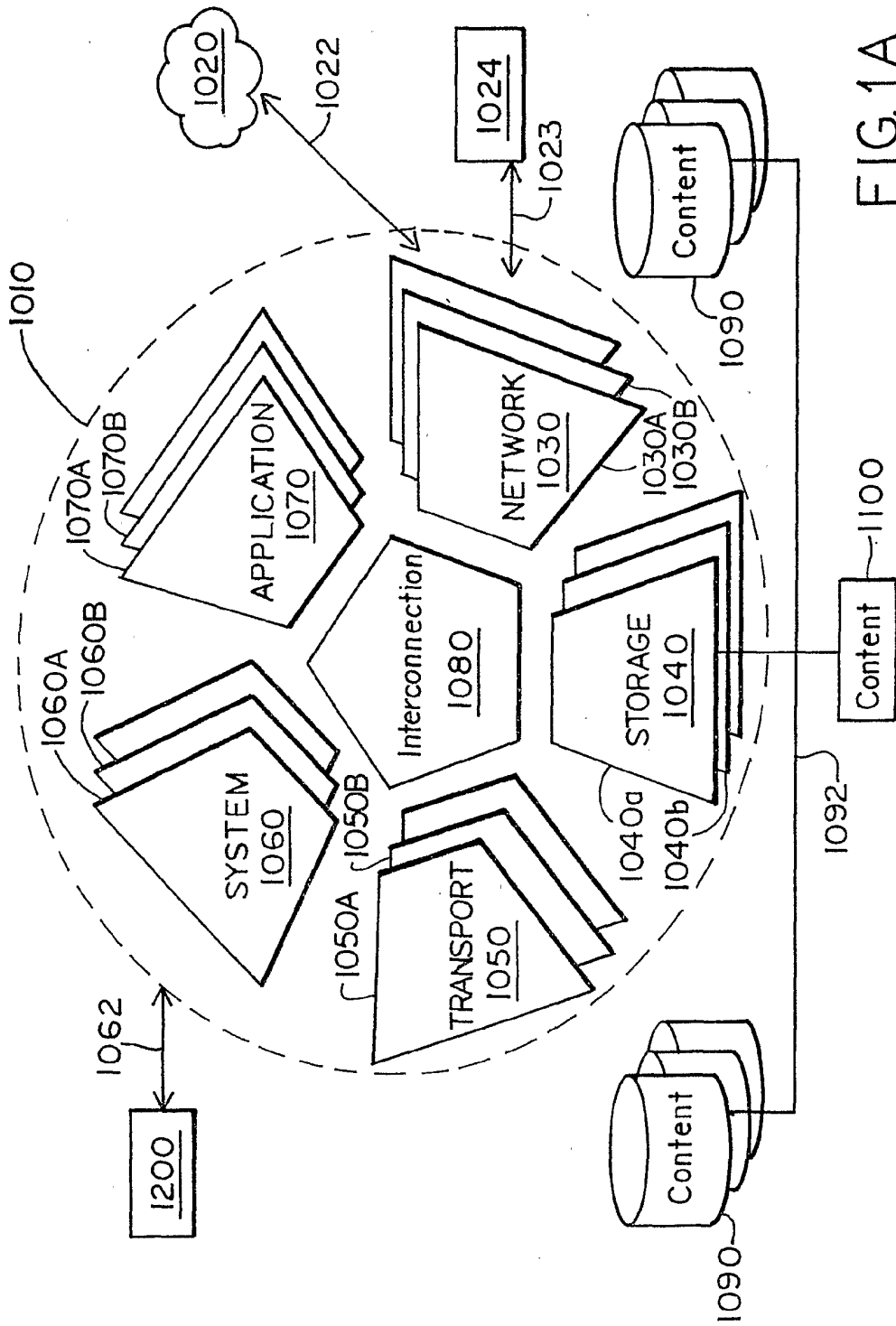

FIG. 1A

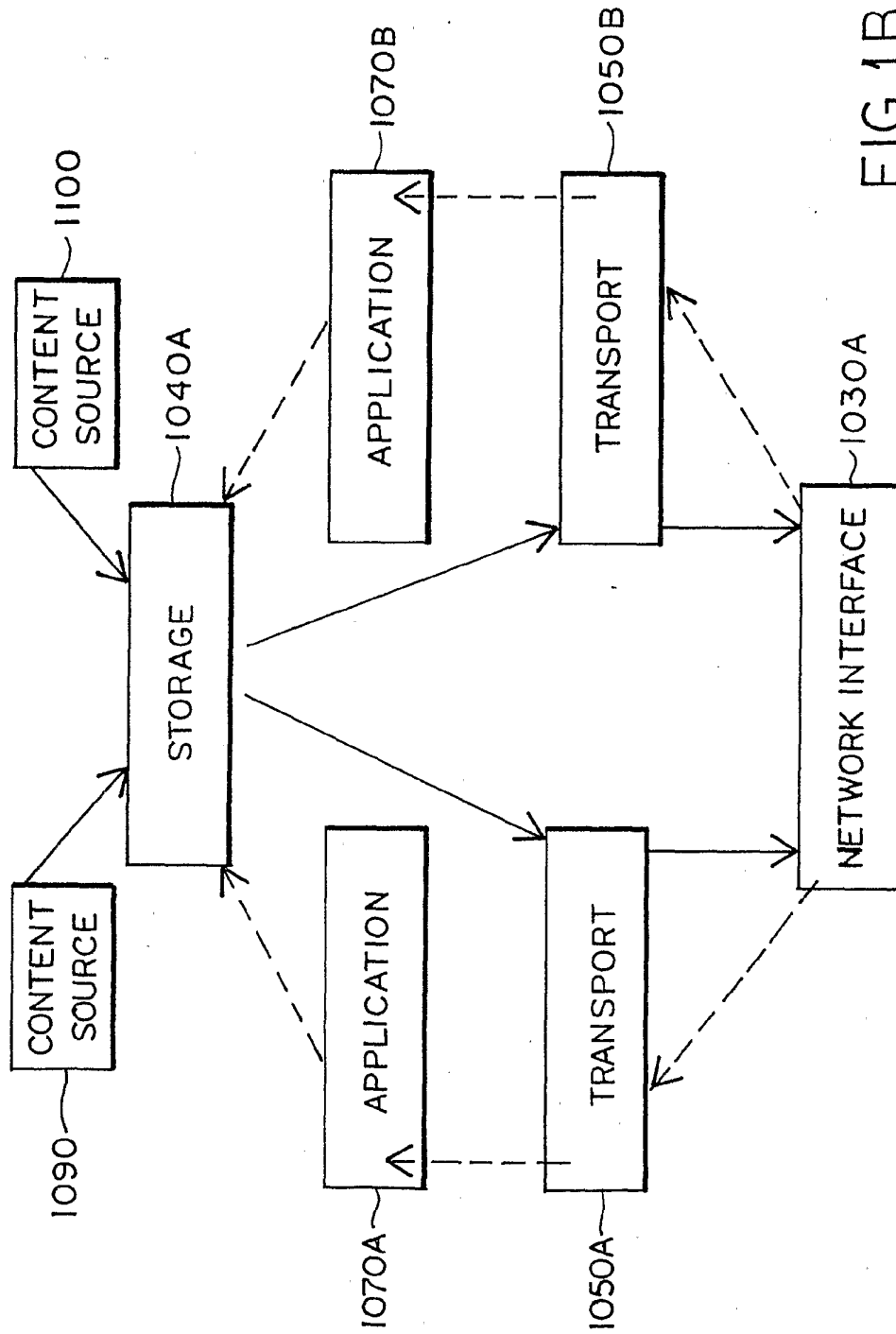

FIG. 1B

FIG. 1C FIG. 1C^I FIG. 1C^{II}

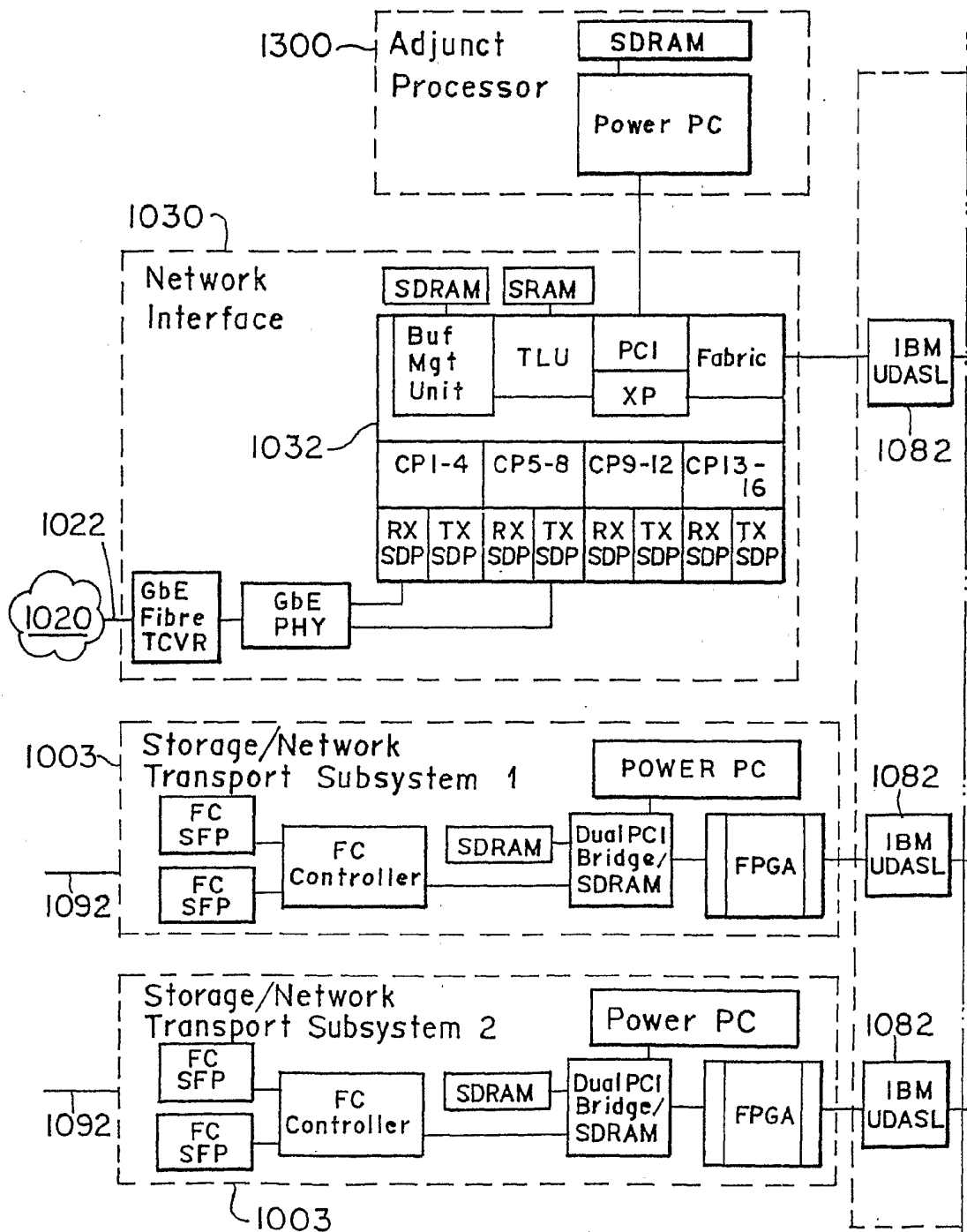

FIG. 1C^I

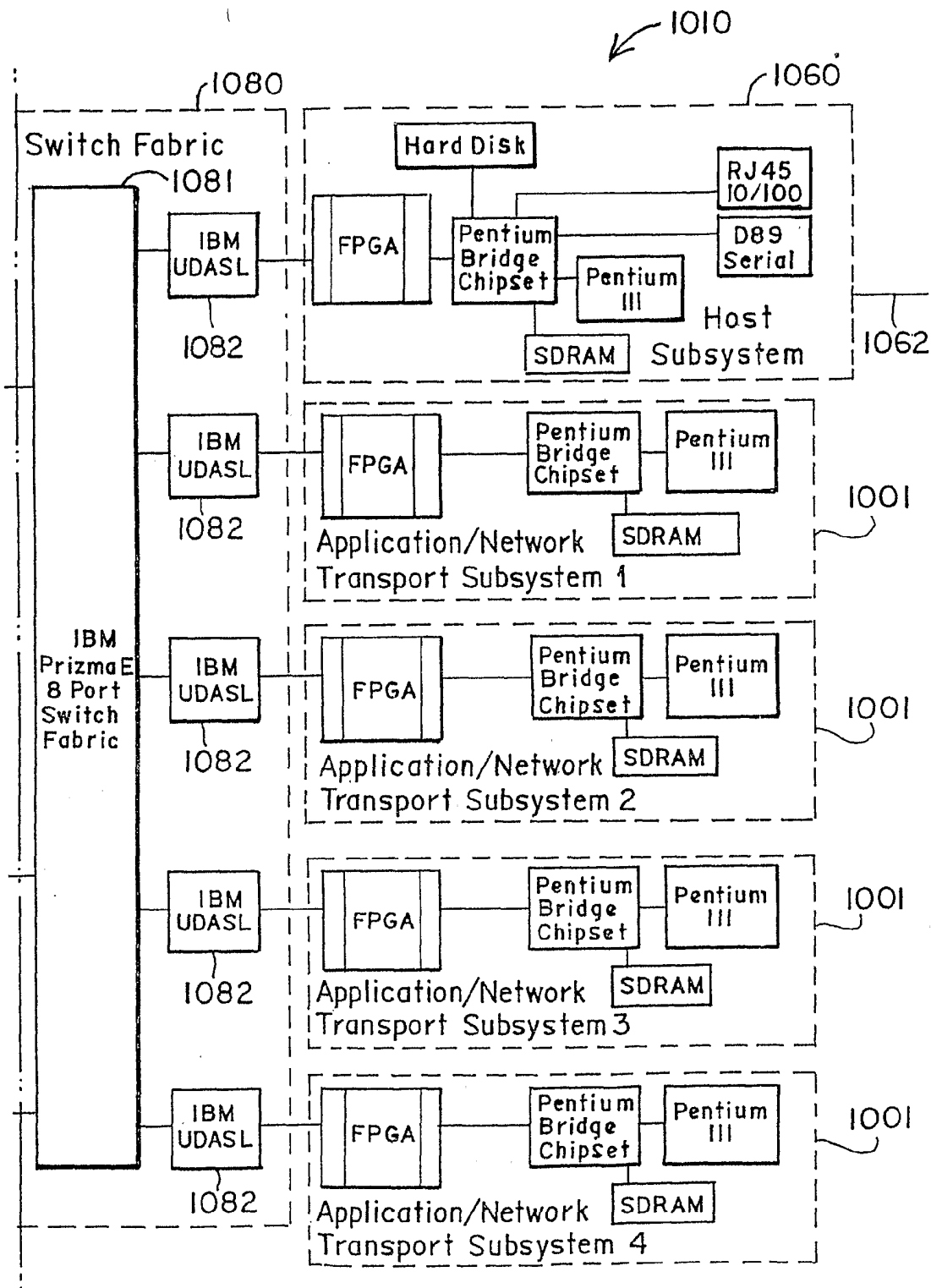

FIG. 10C''

FIG.ID FIG.ID' FIG.ID''

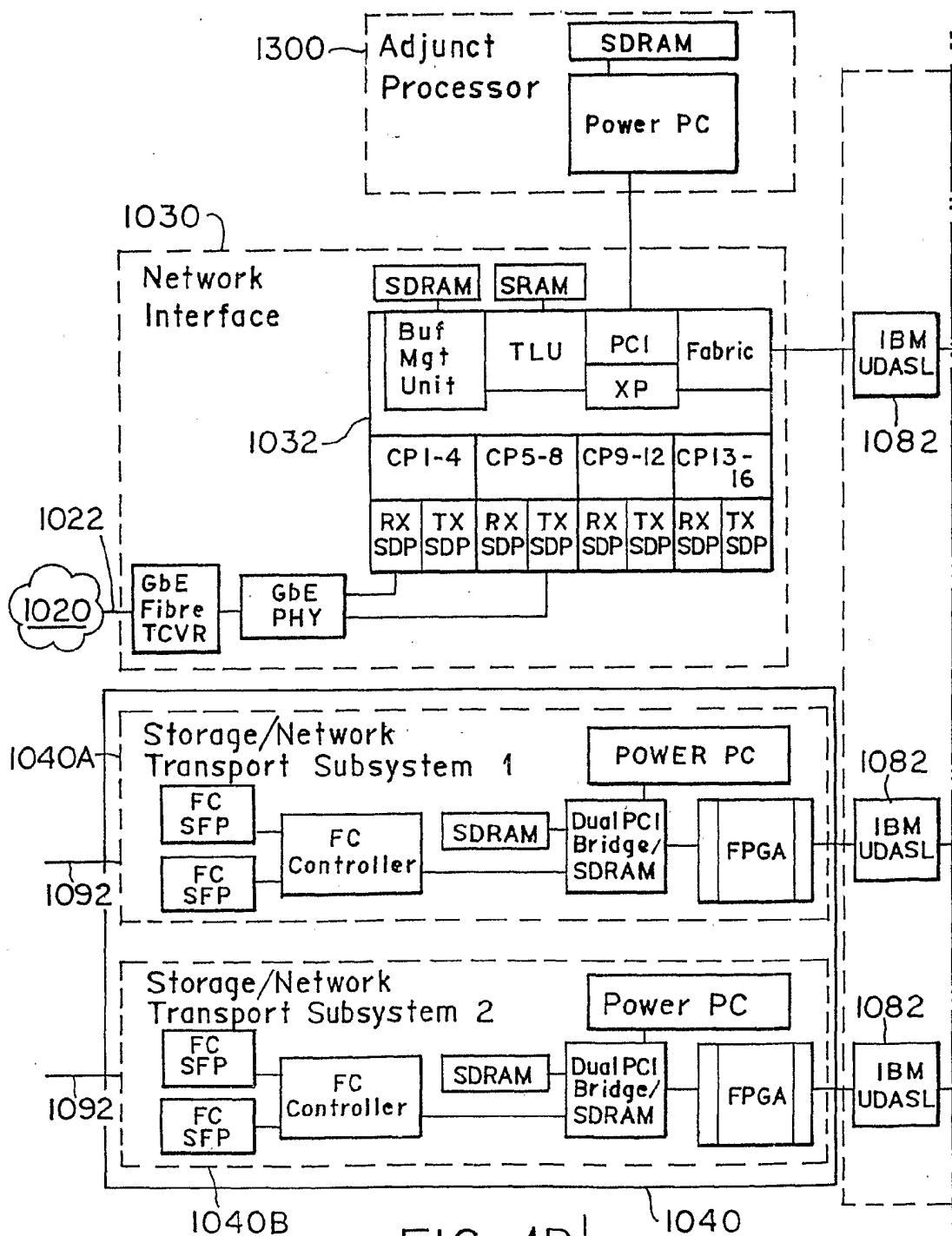

FIG. 1D'

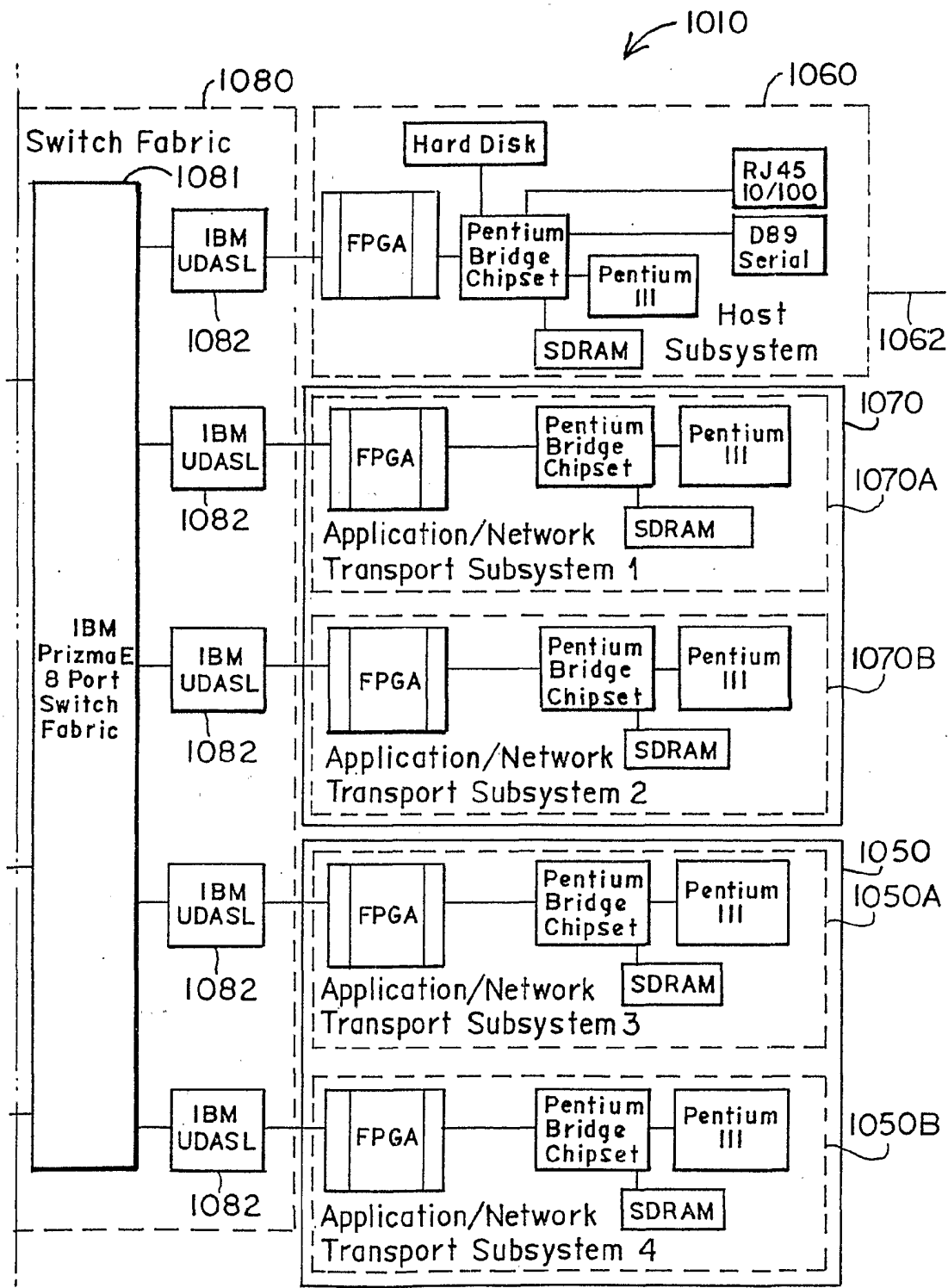

FIG. 1D^{II}

FIG. 1E FIG. 1E^I FIG. 1E^{II}

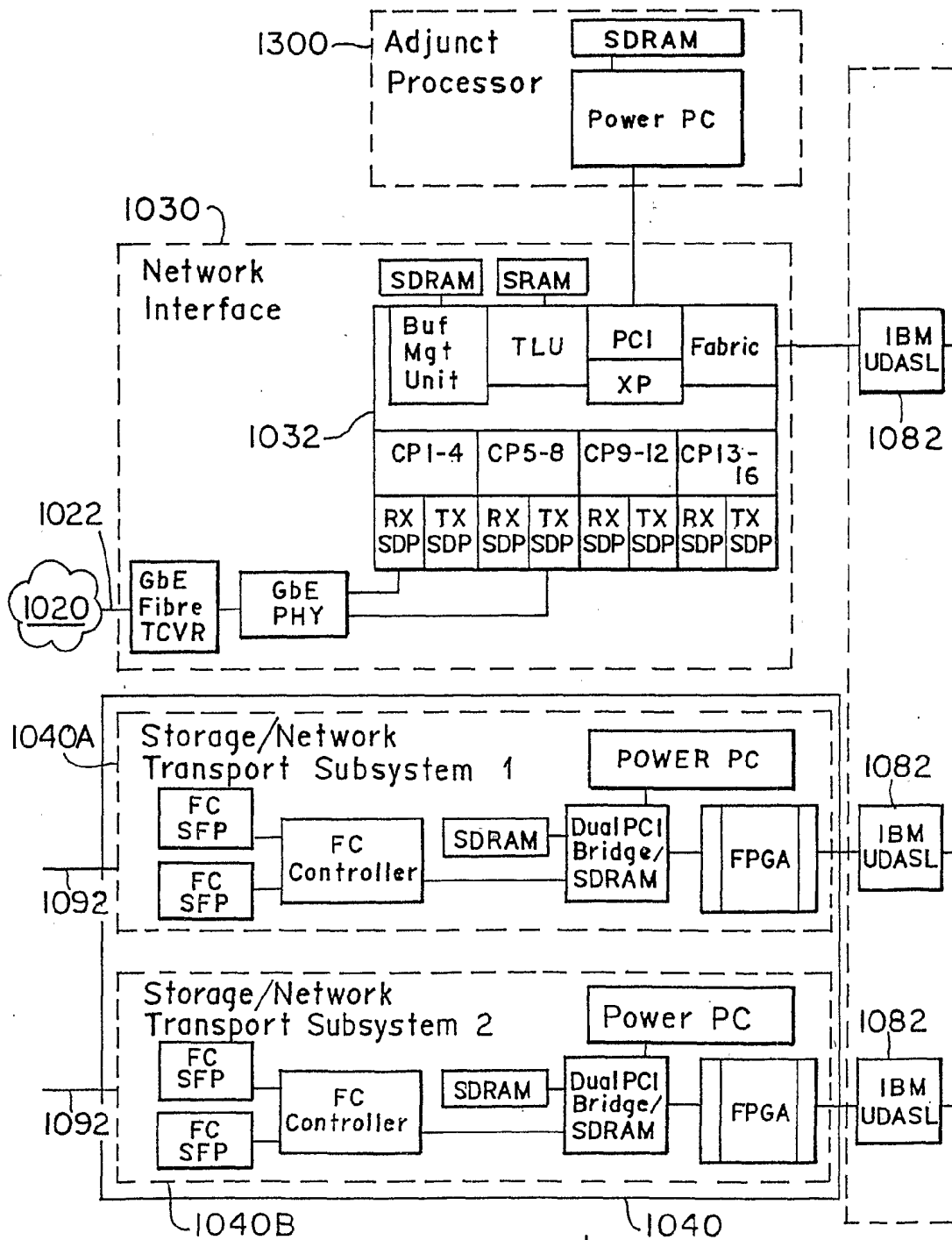

FIG. 1E^I

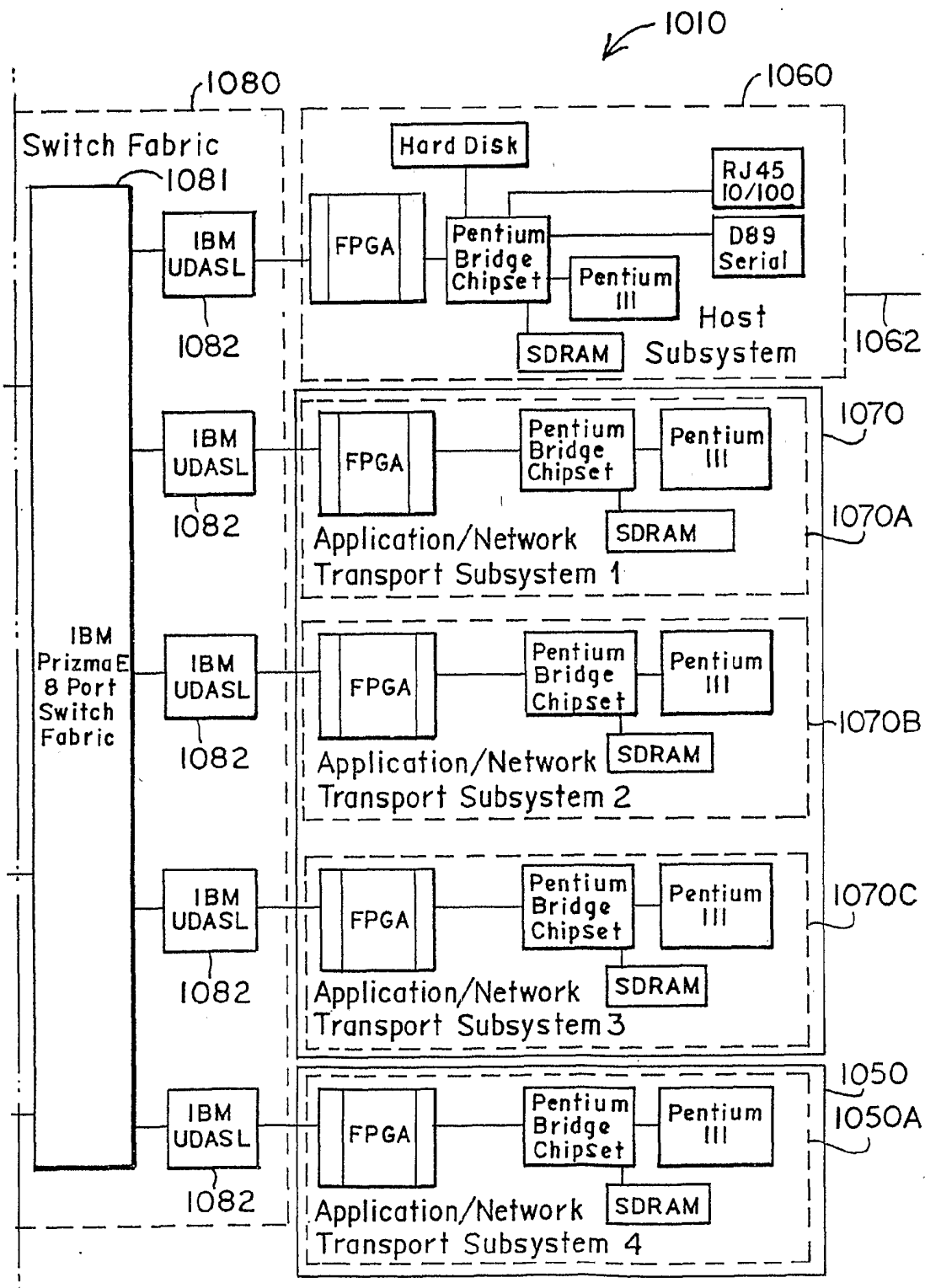

FIG. 1E''

FIG. 1F FIG. 1F^I FIG. 1F^{II}

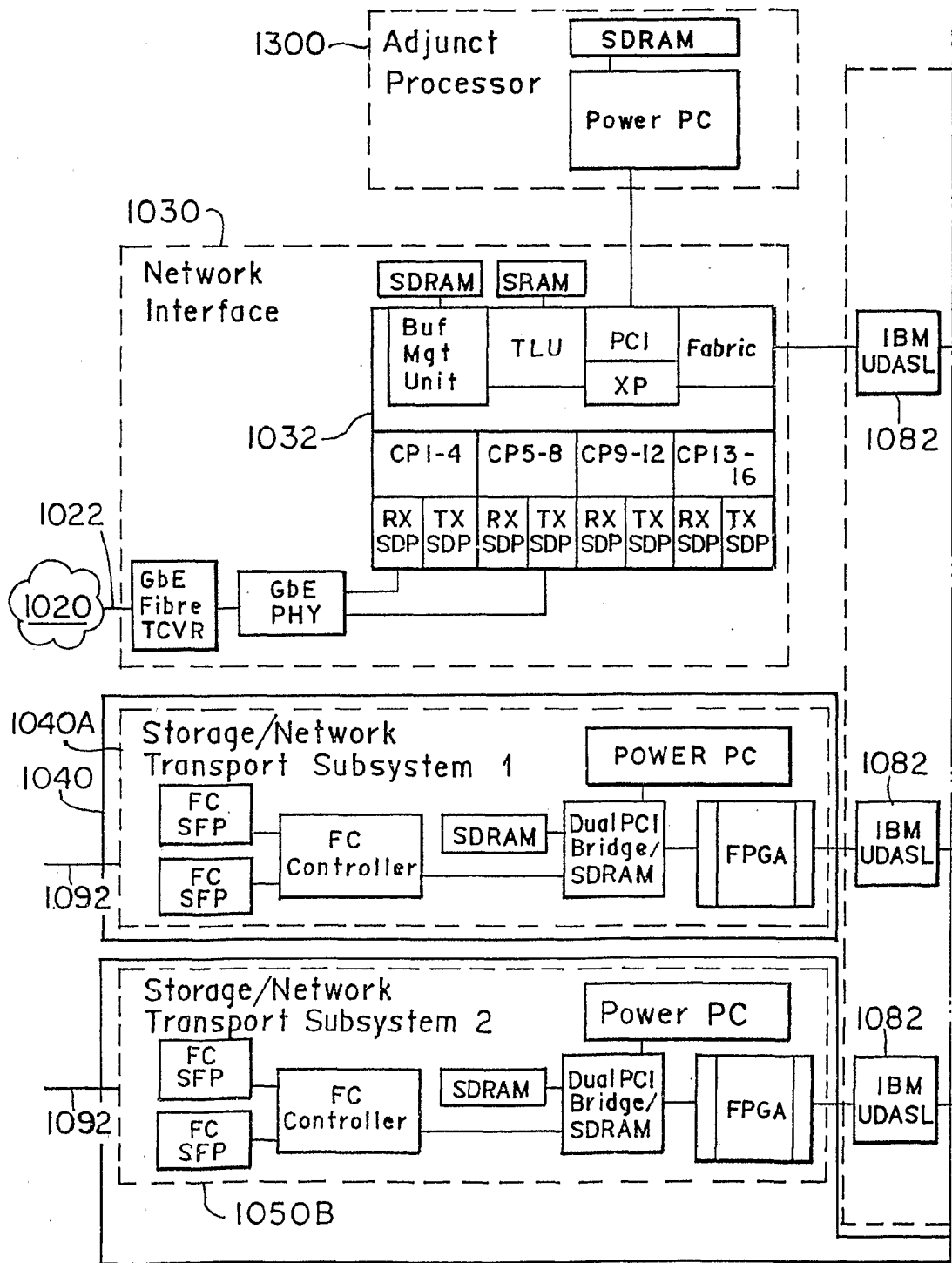

FIG. 1F^I

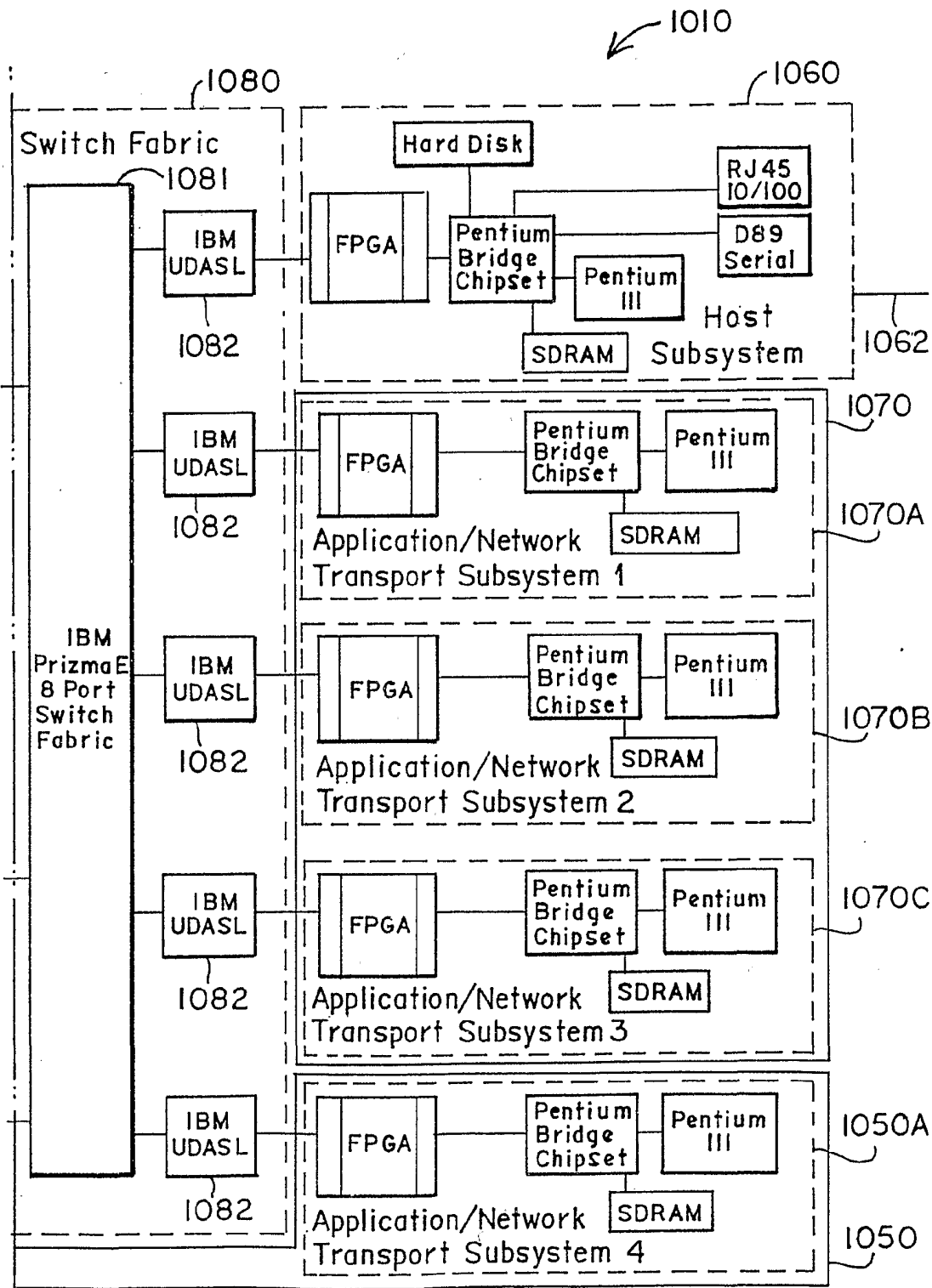

FIG. 1F''

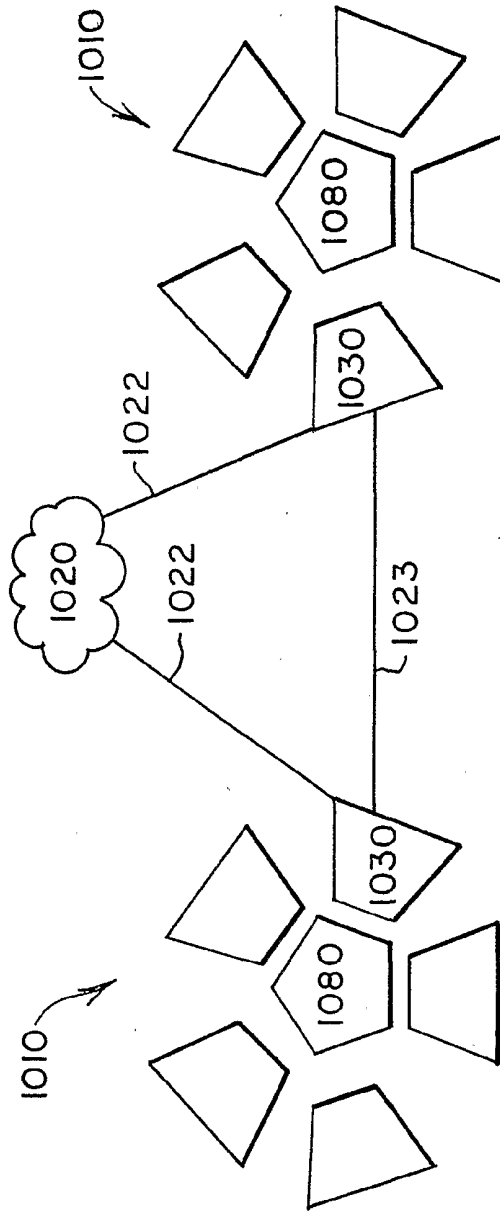

FIG. 1G

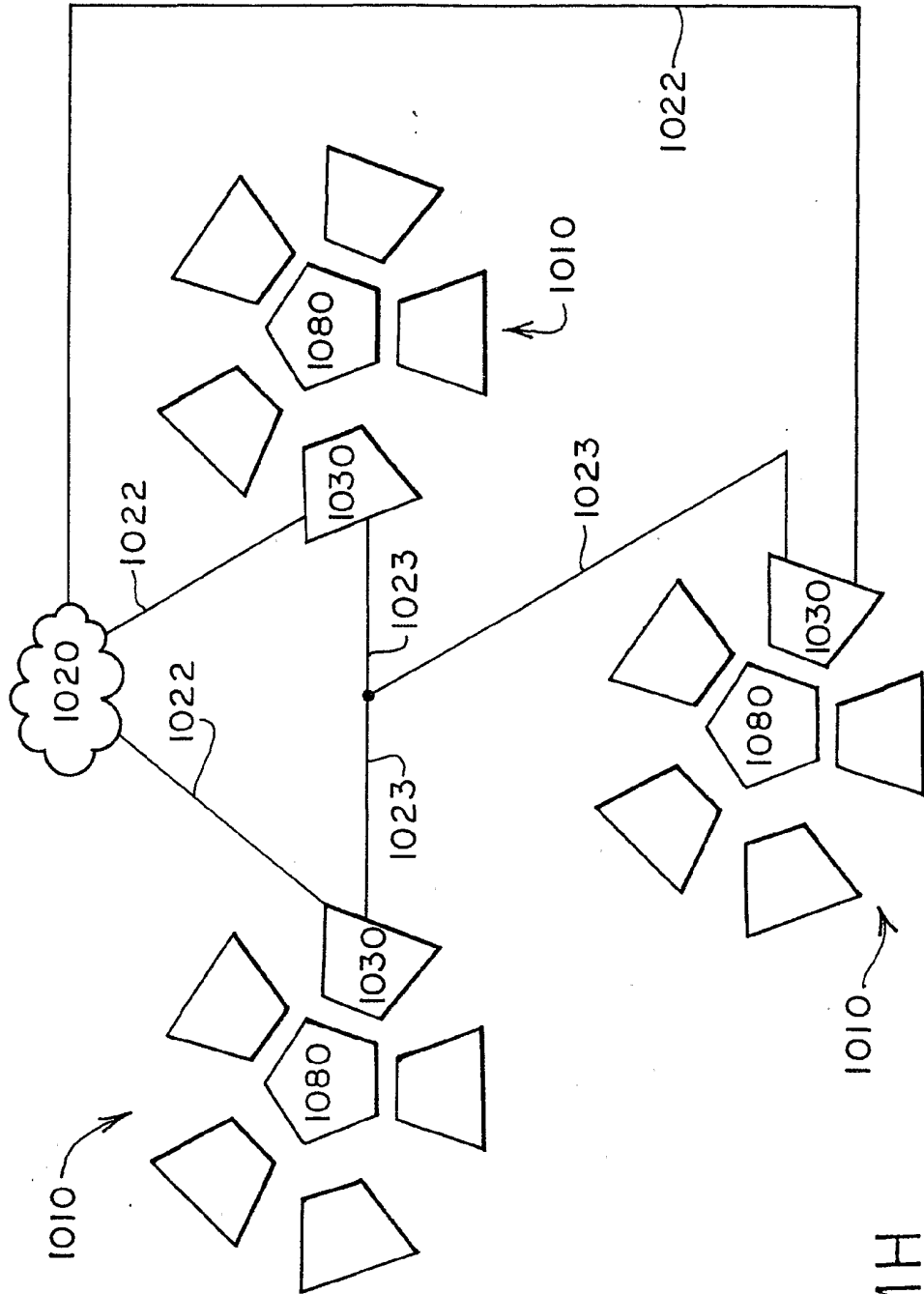

FIG. 1H

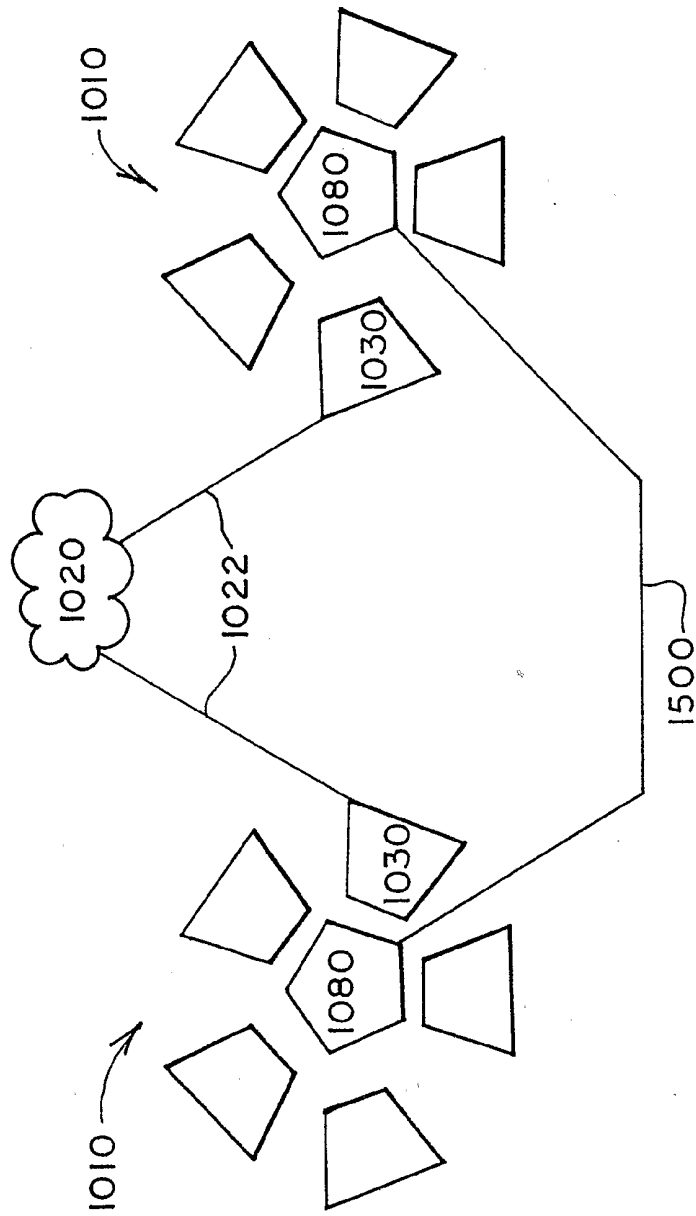

FIG. 1I

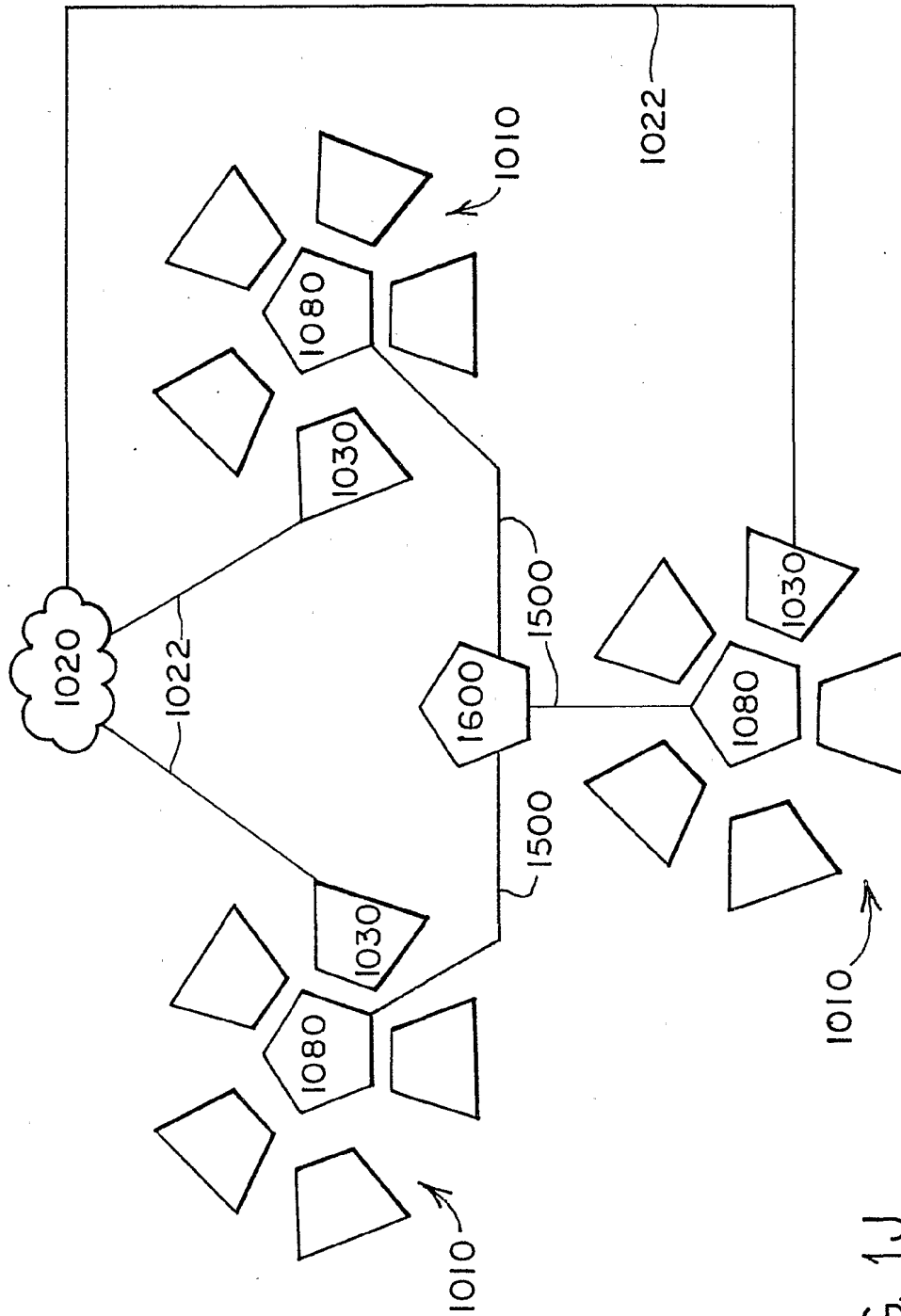

FIG. 1J

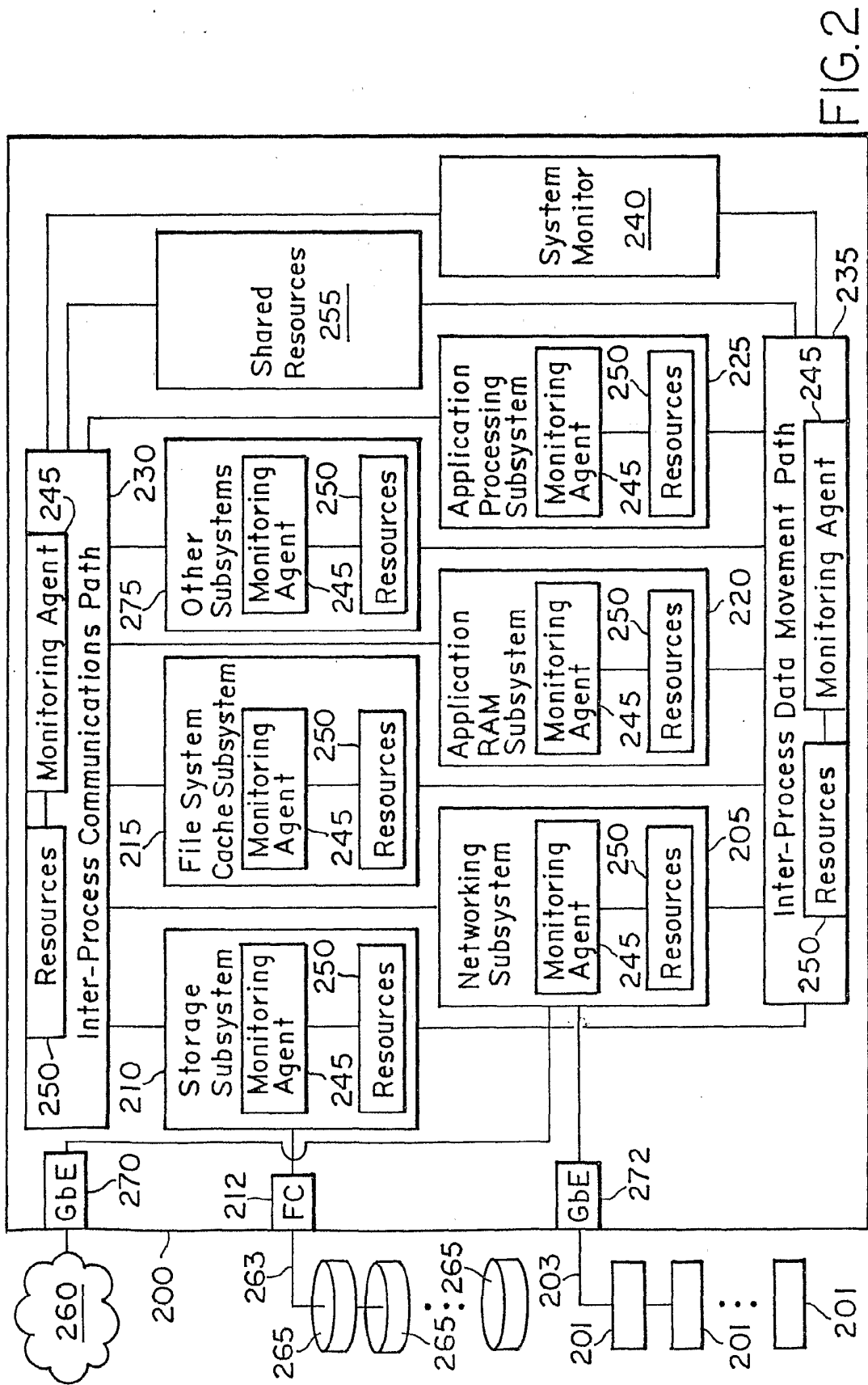

FIG. 2

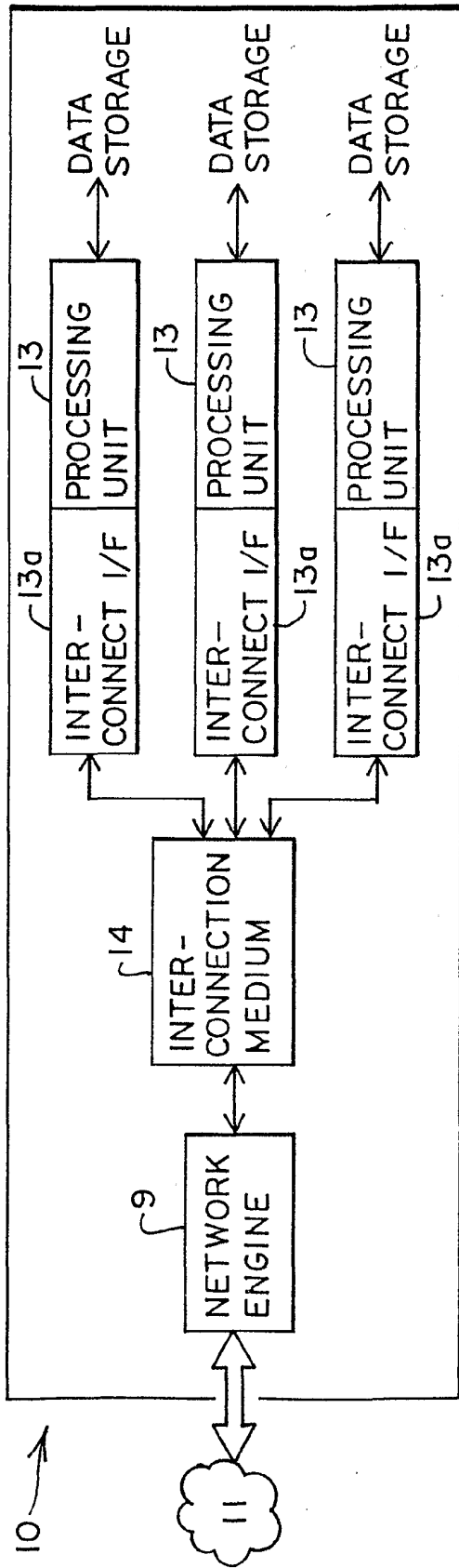

FIG. 2A

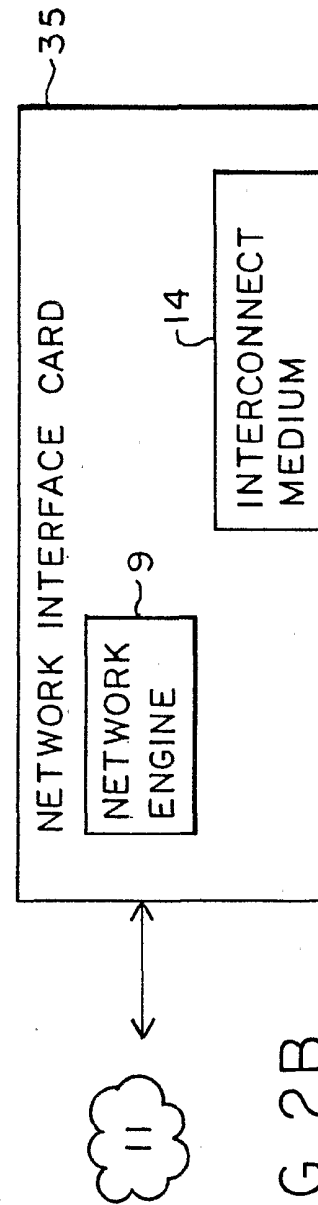

FIG 2B

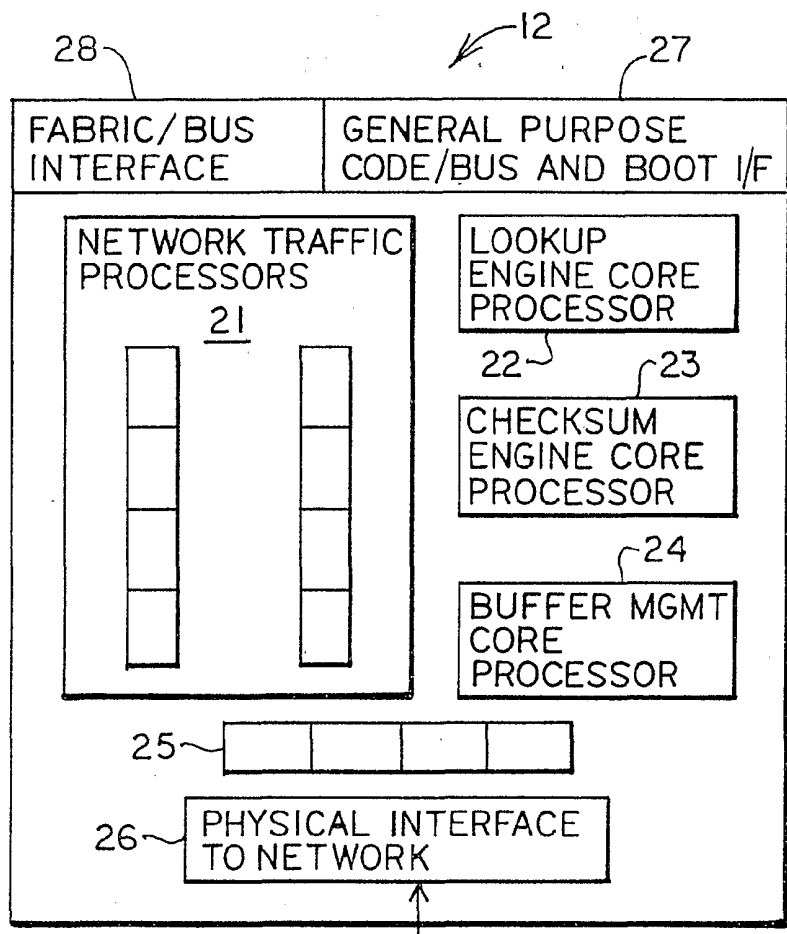

FIG. 3

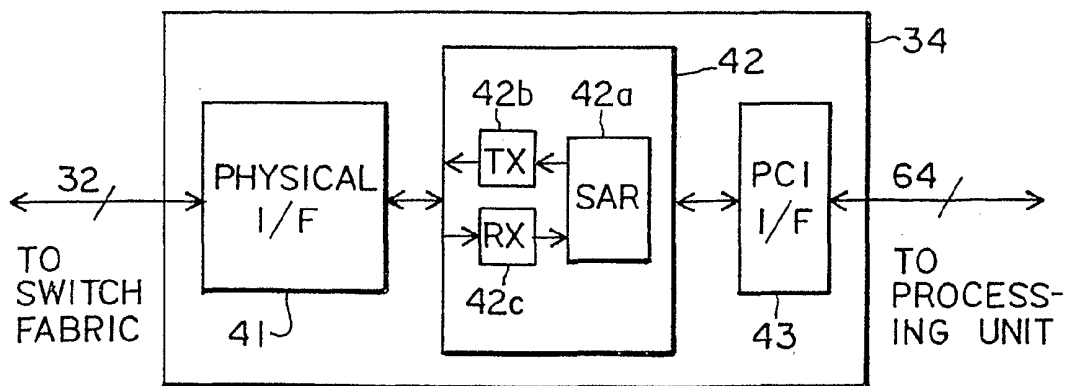

FIG. 4

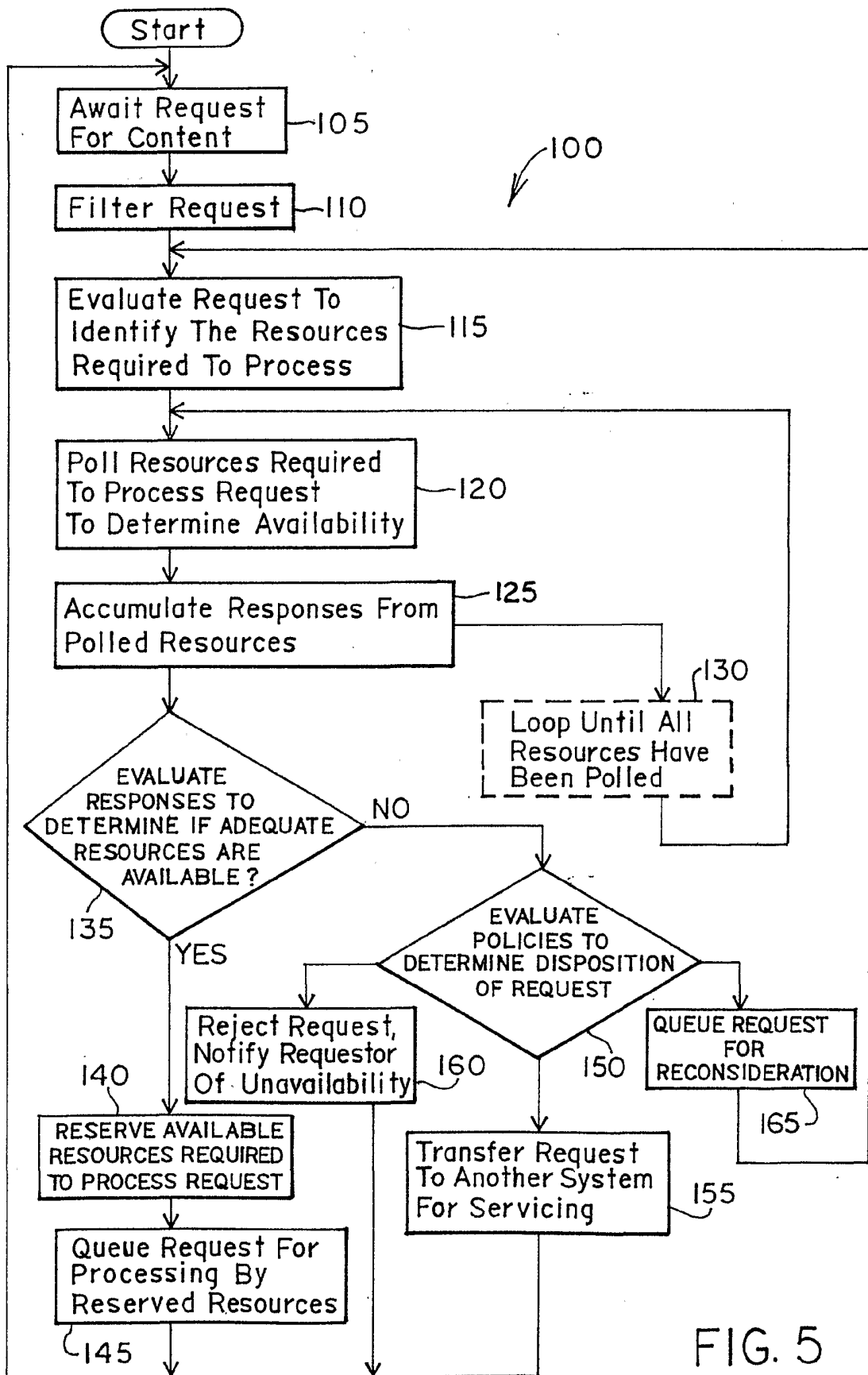

FIG. 5

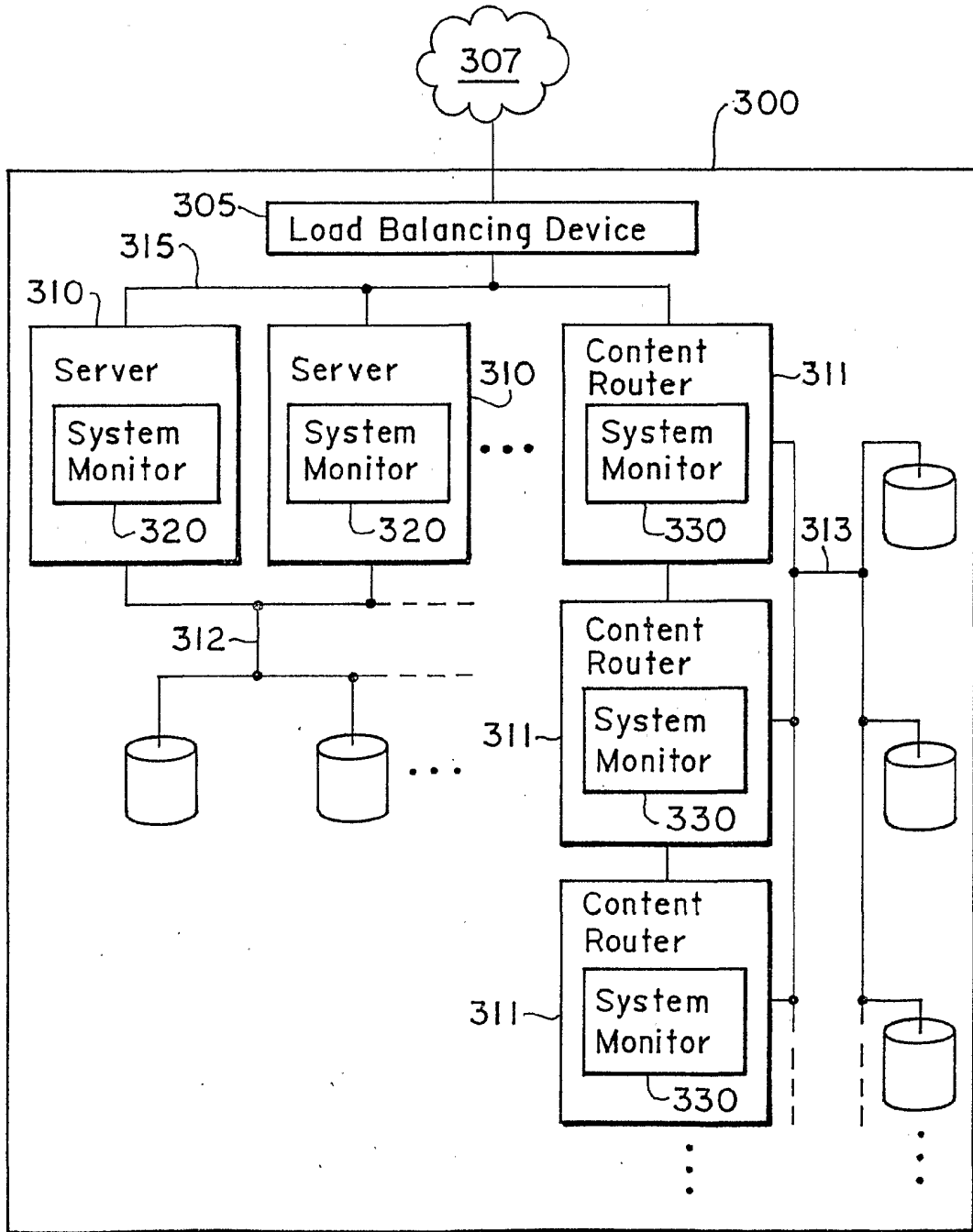

FIG. 6

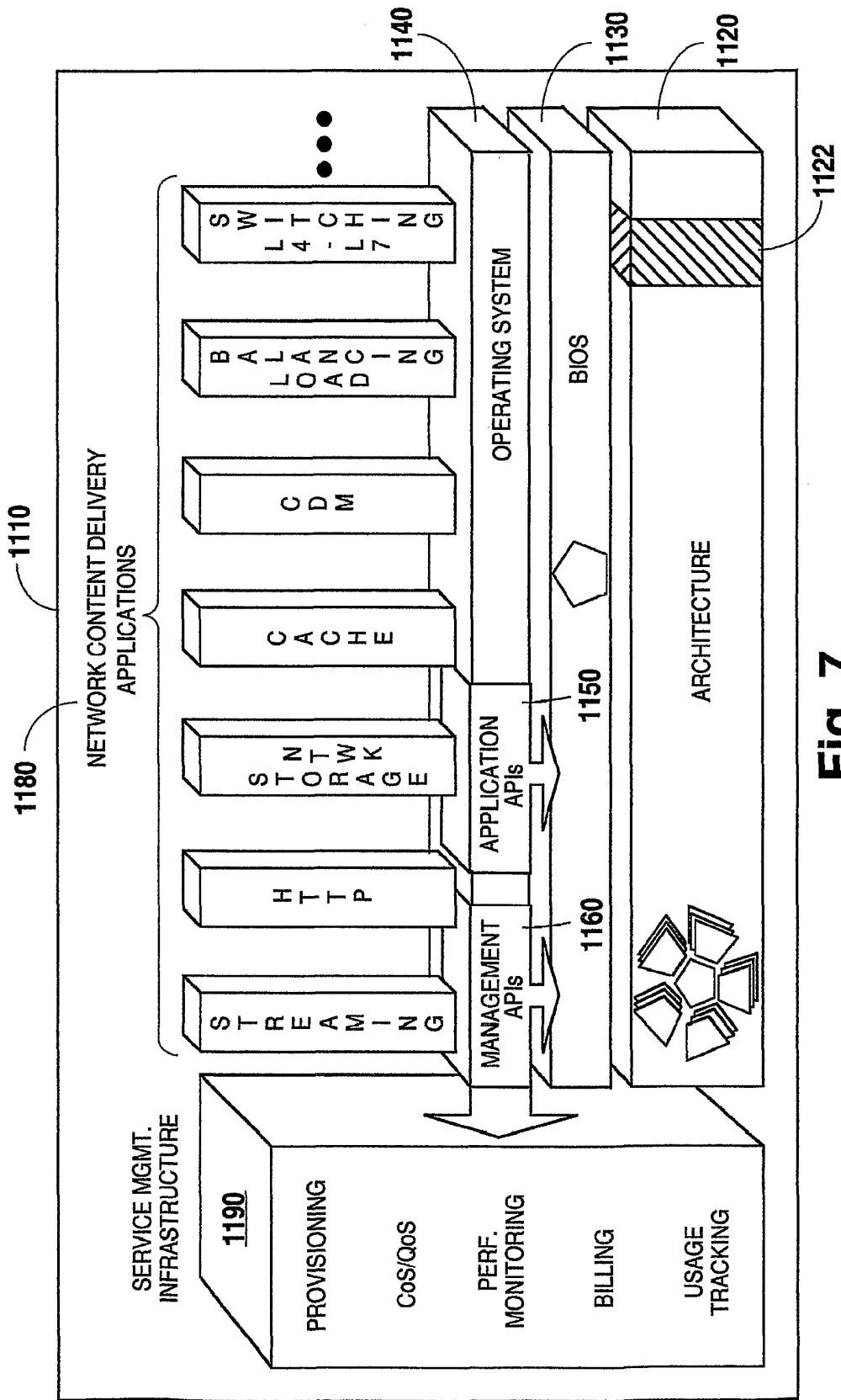

Fig. 7

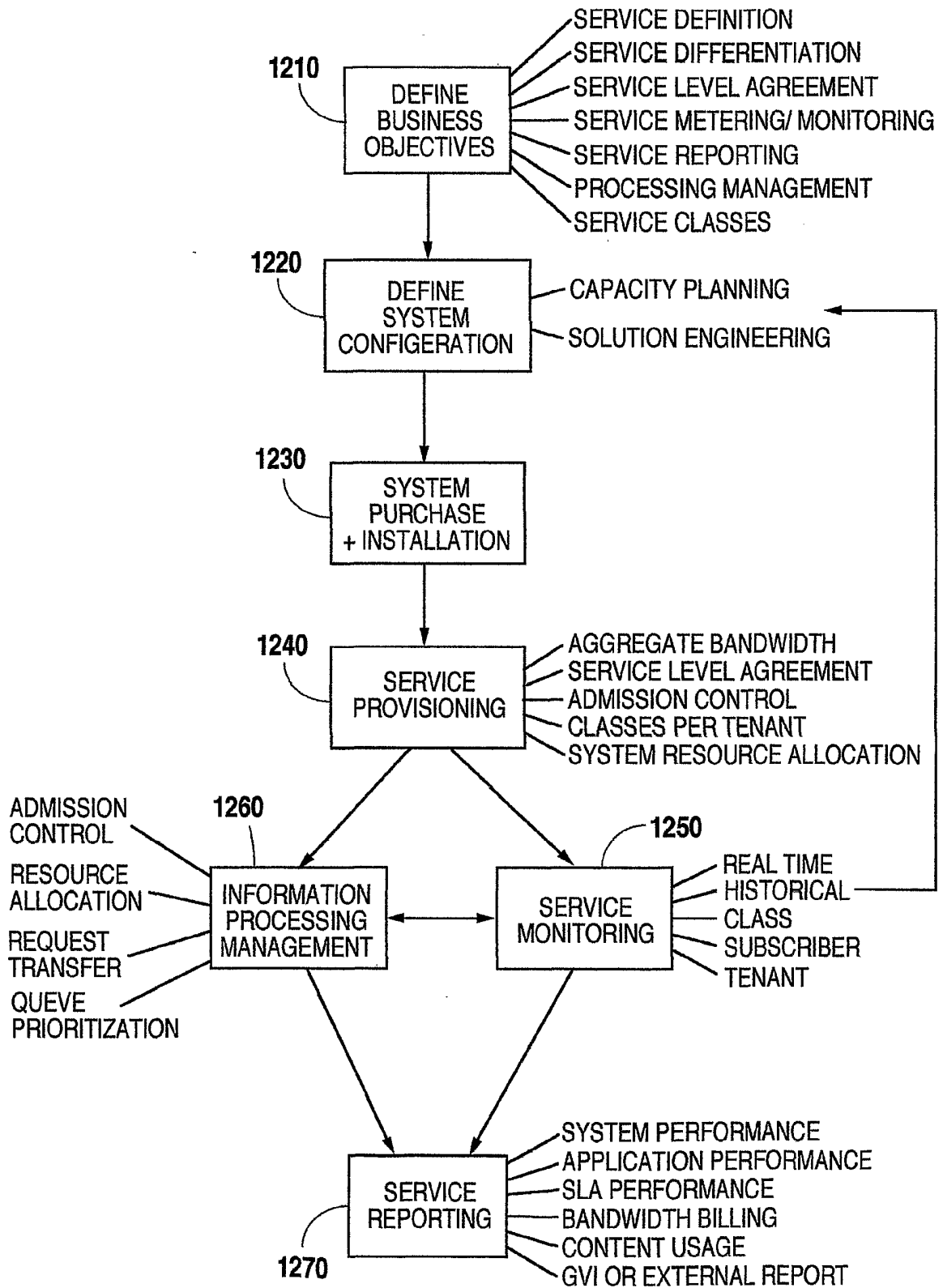

Fig. 8

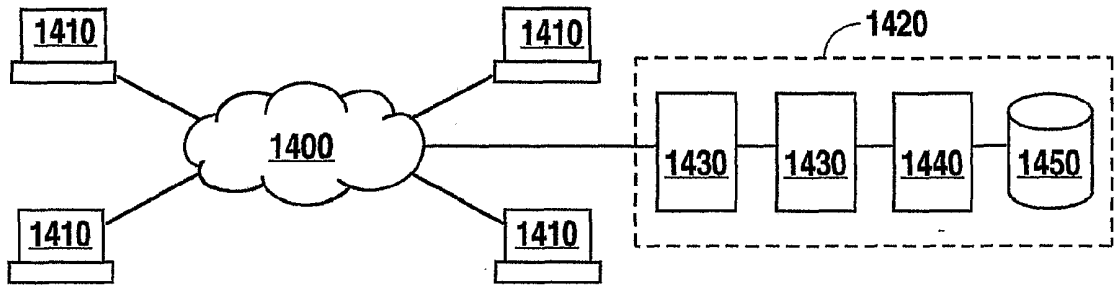

Fig. 9A

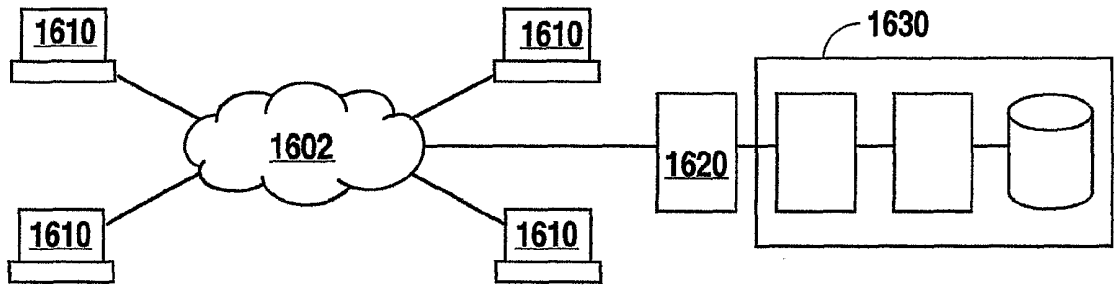

Fig. 9B

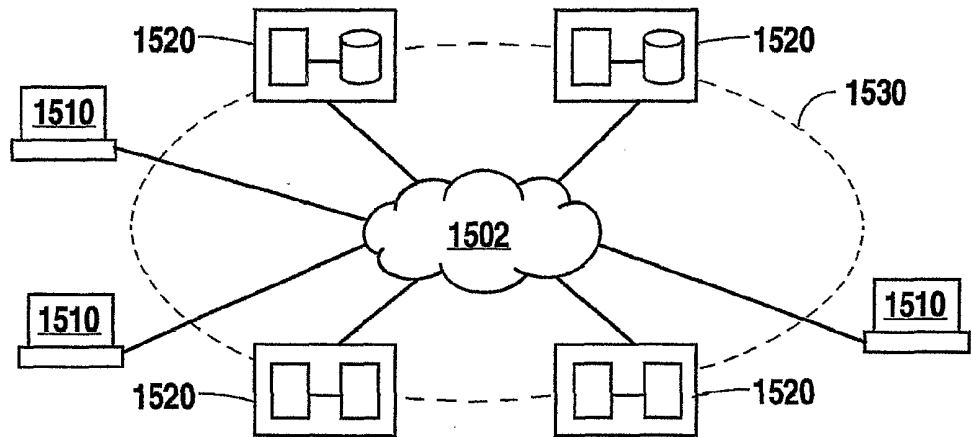

Fig. 9C

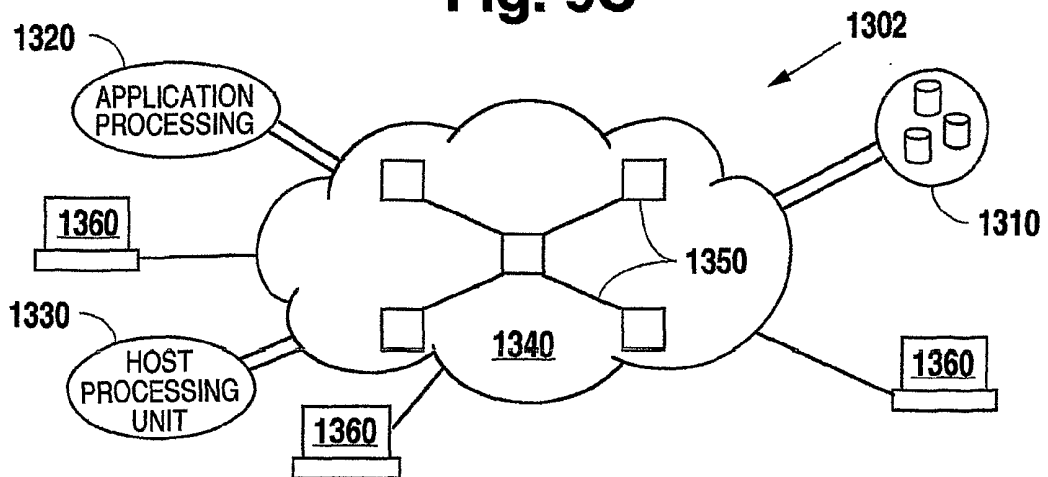

Fig. 9D