

(19)



(11)

EP 3 984 385 B1

(12)

EUROPEAN PATENT SPECIFICATION

(45) Date of publication and mention of the grant of the patent:
06.09.2023 Bulletin 2023/36

(51) International Patent Classification (IPC):
A24F 40/40 ^(2020.01) **A24F 40/42** ^(2020.01)
A24F 40/53 ^(2020.01)

(21) Application number: **20202587.0**

(52) Cooperative Patent Classification (CPC):
A24F 40/40; A24F 40/42; A24F 40/53

(22) Date of filing: **19.10.2020**

(54) VAPORIZER, CONSUMABLE CONTAINER THEREFORE, VAPORIZER SYSTEM THEREOF AND METHOD OF OBTAINING INFORMATION ABOUT A CONSUMABLE CONTAINER

VERDAMPFER, VERBRAUCHSMATERIALBEHÄLTER DAFÜR, VERDAMPFERSYSTEM DAFÜR UND VERFAHREN ZUR GEWINNUNG VON INFORMATIONEN ÜBER EINEN VERBRAUCHSMATERIALBEHÄLTER

VAPORISATEUR, RÉCIPIENT CONSOMMABLE CORRESPONDANT, SYSTÈME DE VAPORISATEUR CORRESPONDANT ET PROCÉDÉ PERMETTANT D'OBTENIR DES INFORMATIONS SUR UN RÉCIPIENT CONSOMMABLE

(84) Designated Contracting States:
AL AT BE BG CH CY CZ DE DK EE ES FI FR GB GR HR HU IE IS IT LI LT LU LV MC MK MT NL NO PL PT RO RS SE SI SK SM TR

(72) Inventor: **BOUCHUIGUIR, Layth Sliman**
1293 Bellevue (CH)

(43) Date of publication of application:
20.04.2022 Bulletin 2022/16

(74) Representative: **Bardehle Pagenberg Partnerschaft mbB Patentanwälte Rechtsanwälte Prinzregentenplatz 7 81675 München (DE)**

(73) Proprietor: **JT International SA 1202 Geneva (CH)**

(56) References cited:
WO-A1-2017/163045 WO-A1-2019/129866
WO-A1-2020/053387

EP 3 984 385 B1

Note: Within nine months of the publication of the mention of the grant of the European patent in the European Patent Bulletin, any person may give notice to the European Patent Office of opposition to that patent, in accordance with the Implementing Regulations. Notice of opposition shall not be deemed to have been filed until the opposition fee has been paid. (Art. 99(1) European Patent Convention).

Description**TECHNICAL FIELD**

5 **[0001]** The present invention is directed to personal vaporizing devices, such as electronic cigarettes. More specifically, the present invention is directed to a vaporizer, a consumable container therefore, a vaporizer system thereof comprising the vaporizer and the consumable container, and a method of obtaining information by the vaporizer about the consumable container.

10 **BACKGROUND**

[0002] Electronic cigarettes are an alternative to conventional cigarettes. Instead of generating a combustion smoke, they vaporize a liquid, which can be inhaled by a user. The liquid typically comprises an aerosol-forming substance, such as glycerin or propylene glycol that creates the vapor. Other common substances in the liquid are nicotine and various flavorings.

15 **[0003]** The electronic cigarette is a hand-held inhaler system, comprising a mouthpiece section, a liquid store, and a power supply unit. Vaporization is achieved by a vaporizer or heater unit which typically comprises a heating element in the form of a heating coil and a fluid transfer element. The vaporization occurs when as the heater heats up the liquid in the wick until the liquid is transformed into vapor. The electronic cigarette may comprise a chamber in the mouthpiece section, which is configured to receive disposable consumables in the form of capsules. Capsules style consumable containers comprising the liquid store and the vaporizer are often referred to as "cartomizers".

20 **[0004]** Different types of e-liquid solutions with different flavors or substances require different settings of the vaporizer, such as heating time and temperature. There is also a need for customers to only consume the authentic consumable container. Information exchange between the consumable container and the vaporizer is thus necessary.

25 **[0005]** The current vaporizers use data communication to identify the consumable container. For example, CN 11095991 A discloses an electronic cigarette including a tobacco/cigarette rod and a cartridge inserted into the tobacco rod. The cartridge includes a PCB module with an authentication circuit. The tobacco/cigarette rod 12 includes pins and a main control module. When the cartridge is coupled to the tobacco/cigarette rod, the connectors contact with the contact pads of the lower end of the PCB module. Further, the main control module detects data information of the authentication circuit 112 electrically connected to the connectors in the PCB module to identify the cartridge. A similar electronic cigarette is known from WO 2019/129866A in which the detection system is mechanically, magnetically or optically actuated.

30 **[0006]** However, the electronic cigarette and the cartridge provided in the prior art is complex in structure. Having a complex IC module in the cartridge also increases the cost of the consumable container.

35

SUMMARY OF THE INVENTION

[0007] The present invention provides a smoking article for an aerosol generation device, which solves some of or all of the above problems.

40 **[0008]** The invention is directed to a vaporizer configured to be connected to a consumable container for vaporizing a consumable contained in the consumable container, a vaporizer connecting surface of the vaporizer being connected to a consumable container connecting surface of the consumable container when the vaporizer is connected to the consumable container, wherein the vaporizer comprises one or more detecting units comprising a resilient member on the vaporizer connecting surface, on which the resilient member can take a projected or retracted position, configured to detect one or more aspects of the shape of the consumable container connecting surface encoding information about the consumable container, by detecting whether or not or to which extent the resilient member is in a projected or retracted position when the vaporizer is connected to the consumable container.

45 **[0009]** With this arrangement, the information about the consumable container can be obtained by the vaporizer in a simple and economical way.

50 **[0010]** In a further embodiment, the resilient member is configured to detect indentations and/or protrusions arranged on a predetermined area of the consumable container connecting surface.

[0011] In a further embodiment, the detecting units are arranged on a main level and/or in a recess underneath the main level of the vaporizer connecting surface.

55 **[0012]** In a further embodiment, the resilient member is configured to detect different depth and/or height levels of the indentations and/or protrusions.

With this arrangement, more complex data can be encoded on the one or more aspects of the shape of the consumable container.

[0013] In a further embodiment, the vaporizer comprises a decoding unit configured to decode the information encoded

by the one or more aspects of the shape of the consumable container connecting surface.

[0014] In a further embodiment, the resilient member is a pogo pin.

[0015] In a further embodiment, the information is further determined by detecting if the pogo pin is electronically connected with a conducting surface of the container.

5 [0016] In a further embodiment, the pogo pins are capable of supplying a power to the consumable container. With this arrangement, the vaporizer system is designed in a more compact way.

[0017] In a further embodiment, the vaporizer comprises an operation unit, which is configured to check a table stored in the vaporizer against data obtained by detecting the one or more aspects of the shape of the consumable container connecting surface.

10 [0018] The invention is also directed to a consumable container configured to be connected to a vaporizer as described and containing a consumable for being vaporized in the vaporizer, the consumable container comprising a consumable container connecting surface being connected to a vaporizer connecting surface of the vaporizer when the consumable container is connected to the vaporizer, the shape of the consumable container connecting surface having one or more aspects which encode information about the consumable container.

15 [0019] In a further embodiment, at least parts of the consumable container connecting surface are made of a conductible material.

[0020] In a further embodiment, the consumable container is powered by an electrical connection between the consumable container connecting surface and the vaporizer connecting surface of the vaporizer.

20 [0021] In a further embodiment, the one or more aspects of the shape of the consumable container connecting surface comprises indentations and/or protrusions at a predetermined area of the consumable container connecting surface.

[0022] In a further embodiment, the information is encoded by the presence of absence of indentations and/or protrusions on the consumable container connecting surface, and/or the depth and/or height levels of the different indentations and/or protrusions.

[0023] The invention is further directed to a vaporizer system comprising a vaporizer and a consumable as described.

25 [0024] The invention is also directed to a method of obtaining information about a consumable container as described, configured to be connected to a vaporizer as described, comprising the step of:

detecting which ones of the resilient members of the vaporizer are pressed down and/or how far a resilient member is pressed down when the vaporizer is connected to the consumable container,

30 decoding the information on the basis of the detection.

[0025] In a further embodiment, the information is decoded by checking a table stored in the vaporizer against data obtained by the detection.

35 [0026] In a further embodiment, the method comprises the step of indicating at least some of the obtained information to the user.

[0027] In a further embodiment, the information is indicated by activating one or more LEDs comprised by the vaporizer. Preferred embodiments are now described, by way of example only, with reference to the accompanying drawings.

BRIEF DESCRIPTION OF THE DRAWINGS

40 [0028]

45 Figures 1a and 1c: show a schematic perspective view, a schematic perspective side view, and an exploded schematic perspective view of an electronic cigarette according to an exemplary embodiment of the present invention;

Figures 2a to 2c: shows a schematic view of a consumable container, a vaporizer and an exploded schematic view of a detecting unit according to an exemplary embodiment of the present invention;

50 Figures 3a to 3e: shows partial cross section views of the detecting units installed in the vaporizer, and schematic perspective views of detecting units in different status according to embodiments of the invention;

Figures 4a and 4b: show schematic perspective views of detecting units being in use with a part of the consumable container according to embodiments of the invention;

55 Figure 5: shows a flow chart of a process of obtaining information by the vaporizer about a consumable container according to an embodiment of the invention.

DETAILED DESCRIPTION OF THE PREFERRED EMBODIMENTS

[0029] Preferred embodiments of the present invention are described hereinafter and in conjunction with the accompanying drawings.

5 [0030] As used herein, the term "vaporizer system", "inhaler" or "electronic cigarette" may include an electronic cigarette configured to deliver an aerosol to a user, including an aerosol for smoking. The illustrated embodiments of the vaporizer system in this invention are schematic, and it is also possible to combine some of the parts to single units which will be apparent to a person skilled in the art.

10 [0031] Referring to the drawings and in particular to figures 1a, 1b and 1c, an electronic cigarette for vaporizing an e-liquid is illustrated. The electronic cigarette 3 can be used as a substitute for a conventional cigarette. The electronic cigarette 3 has a vaporizer main body 1 comprising a container seating, an LED light 110, a power supply unit, and an electrical circuitry. A container seating is configured to receive removable consumable container 2 comprising a vaporizing e-liquid. The e-liquid may comprise an aerosol-forming substance such as propylene glycol and/or glycerol and may contain other substances such as nicotine and acids. The e-liquid contained in the consumable container 2 may also
15 comprise different types of flavorings such as tobacco, menthol or fruit flavor. The container seating is preferably in the form of a cavity configured to receive the consumable container 2 as shown in figure 1c. The consumable container 2 comprises an e-liquid chamber unit portion, on the insertion side, and a mouthpiece portion 210, on the opposite side of the insertion side. The mouthpiece section 210 has a tip-shaped form with an air outlet at one end to correspond to the ergonomics of the user's mouth. The e-liquid chamber unit 204 is located at the opposite end of the consumable
20 container 2 to the mouthpiece portion 210. The chamber unit 204, shown in more detail in figure 2a, may have a transparent wall, in which elements well known to the skilled person such as a tubular vapor channel, liquid uptake portions, a heating element and a fluid transfer element etc. are configured.

[0032] Figure 1c shows the surfaces through which the consumable container 2 contacts the vaporizer when the consumable container 2 is connected to the vaporizer 1 for use. They comprise a first consumable container connecting
25 surface 221, on a distal end of the chamber unit 204 to the mouthpiece portion 210, and a second consumable container connecting surface 220, on an end of the mouthpiece portion close to the chamber unit 204. In another embodiment, the consumable container 2 may have only one surface connecting the vaporizer main body 1. In yet other embodiments, there may be more than two connecting surfaces between the vaporizer main body 1 and the consumable container 2.

[0033] On the first consumable container connecting surface 221, the consumable container 2 is configured with two
30 power terminals 45, and air inlets 35. On the second consumable container connecting surface 220, an information coding area (shown in the square of broken lines in figures 1c, 2a, 4a and 4b) is shaped with one or more aspects which encode information about the consumable container. In the embodiment according to figure 1c, multiple protrusions 201 are provided and shaped on the second consumable container connecting surface 220.

[0034] In the embodiment according to figure 2a, multiple indentations 201 in arc shapes, which have a size that can
35 contain the resilient members therein without connecting when the vaporizer main body 1 and the consumable container 2 are connected, are provided and shaped on the second consumable container connecting surface 220. In other embodiments, both indentations and protrusions 201 are shaped on the consumable container connecting surface. The protrusions and/or indentations 201 have one or more aspects in the form of a machine-readable pattern representing coded authentication information. In other embodiments, the protrusions and/or indentations 201 may also contain
40 information about the consumable or the container 2, such as the types thereof or relative setting data of the vaporizer 1 for the container 2. The encoding method for the aspects of the shape formed on the consumable container connecting surface 210 is discussed below.

[0035] In some embodiments, at least a part of the protrusions is made of a conductible material and integrated with
45 a power inlet of the consumable container 2 so that at least a part of the protrusions 201 can serve as power terminals 202 of the consumable container 2, with the benefit of no need of setting another power source to the container 2 and a more compact design.

[0036] Figure 2b shows a closer schematic view of the container seating, looking at it from the vaporizer main body
50 1 in the insertion direction. The container seating is provided with connection portions 103 and 105 configured to hold the container firmly to the container seating 2 in a snap fit and magnetic fit way. The connection portion could also for instance be an interference fit, a screw fit, or a bayoneted fit. The container seating further comprises a pair of electrical connectors 104 configured to engage with corresponding power terminals 202 on the consumable container 2.

[0037] Similar to the consumable container 2, the vaporizer main body 1 may comprise at least two surfaces which
55 contact the consumable container 2 when the consumable container 2 is connected to the vaporizer 1 for use. The first vaporizer connecting surface 121 is located where the electrical connectors 104 are arranged. The second vaporizer connecting surface 120 has a detecting area (shown in the square with broken lines) arranged thereon, with at least one or more detecting units 101. In another embodiment, the consumable container 2 may have only one surface connecting the vaporizer main body 1, on which the detecting area is arranged. In yet other embodiments, there may be more than two connecting surfaces between the vaporizer main body 1 and the consumable container 2, and the

detecting area may be arranged on multiple surfaces. As shown in figure 2b, the detecting area is arranged on a predetermined area of the vaporizer connecting surface 120. In some embodiments, the detecting area, together with the information coding area, are arranged at opposite regions of the vaporizer connecting surface 120 and the consumable connecting surface 220, so that the consumable container 2 can be detected independent of the direction in which the consumable container 2 is inserted in the vaporizer seating. In other embodiments, the detecting area may be arranged on the entire surface, namely on the entire circle surface of the second vaporizer connecting surface 120.

[0038] The detecting units 101 comprise a resilient member connected with a sensor. The detecting units 101 arranged in the detecting area of the vaporizer correspond to the one or more aspects of the shape of the consumable container connecting surface. The resilient members are configured to detect one or more aspects of the shape of the consumable container connecting surface encoding information about the consumable container, by detecting whether or not or to which extent the resilient member is in a projected or retracted position when the vaporizer main body 1 is connected to the consumable container 2.

[0039] Figure 2c shows an exploded schematic view of the detecting unit 101 according to an embodiment of the invention in detail. In this embodiment, the detecting unit 101 may be assembled from a barrel 1011, a plunger head 1012, a ball 1013, a spring 1014 and a pressure sensor 1015. In some embodiments, the resilient member may be completely made of metal. When the protrusions or the vaporizer connecting surface touches the detecting unit after the container 2 is inserted completely in the vaporizer 1, a force is applied to the plunger head 1012. The spring 1014 is thus compressed and the plunger head 1012 and the balls 1013 move inside the barrel 1011. The barrel 1011 retains the plunger head 1012 and the spring from pushing it out when the plunger head 1012 is not locked in place. The force is then transferred to the pressure sensor, which is connected to a decoding unit comprised by the vaporizer.

[0040] The decoding unit is configured to decode the information encoded by the one or more aspects of the shape of the consumable container connecting surface. The decoding unit decodes the information by determining which ones of the resilient members 101 are pressed down (retracted) when the vaporizer 1 is connected to the consumable container 2. In some embodiments, the decoding unit decodes the information by determining how far the resilient members are pressed down, namely by detecting the strength of the pressure by means of the pressure sensor 1015, when the vaporizer 1 is connected to the consumable container 2. As shown in figures 3c to 3e, from a projected position, via a half-way retracted position to a fully retracted position, the resilient members may be configured to detect different depth and/or height levels of the indentations and/or protrusions 201 which are encoded with and represent different information. The decoding unit is further electronically connected to an operation unit in the vaporizer, which is configured to check a table stored in the vaporizer against obtained pressure data. The pressure sensor, the decoding unit and the operation unit can be of any type that exists in the prior art. The ball 1013 is configured inside the detecting unit 101 so as to stabilize the contacting areas for a better performance. Other kinds of arrangements, such as "back drill style" or "bias tail style", which do not have a ball arranged inside the barrel can also be applied to the detecting unit 101. In some embodiments, the sensor 1015 may be a sensor which senses whether the plunger head 1012 has been electronically connected with a conducted surface of the container 2 so as to determine which ones of the resilient members have been pressed down. Preferably, the resilient members are pogo pins.

[0041] As shown in figures 3a and 3b, there are at least two types of arrangements for the detecting units 101 are arranged on a main level and/or in a recess underneath the main level of the vaporizer connecting surface. As shown in figure 3a, the detecting unit in projected position may be partially arranged above the vaporizer main level of the connecting surface 120. The plunger head 1012 is exposed on the vaporizer connecting surface 120 and is pressed down if the container connecting surface 220 on the container connecting surface 220 touches the plunger head when the container 2 is installed and fixed on the vaporizer. On the other hand, the plunger head 1012 is not pressed down if the plunger head 1012 fits in an indentation 201 of the container connecting surface 220 when the container 2 is connected to the vaporizer main body 1. In another arrangement, as shown in figure 3b, the detecting unit 101 in projected position is arranged entirely in a recess formed by the connecting surface 120, and therefore underneath the main level of the vaporizer connecting surface 120. The detecting unit 101 is pressed down (retracted) when a protrusion on the container connecting surface 220 touches the plunger head 1012 when the container 2 is connected to the vaporizer main body 1.

[0042] As discussed above, the information may be encoded by the presence of absence of indentations and/or protrusions 201 on the consumable container connecting surface, and/or the depth and/or height levels of the different indentations and/or protrusions 201 as shown in figures 3c to 3e. In embodiments where multiple detecting units 101 are arranged in the detecting area, the pattern of the indentations and/or protrusions 201 may represent binary-coded data. Any known binary coded formats can be used, such as ASCII, Unicode, GBK, GBK2312, UTF-8. Any kind of information related to the consumable container 2 can be encoded by the indentations and/or protrusions 201.

[0043] Hereinafter, two embodiments of the process of obtaining information by the vaporizer 1 about a consumable container 2 are discussed with regard to figures 4a and 4b together with figure 5.

[0044] According to an embodiment in which the information is encoded as binary data. When the consumable container 2 is connected to the vaporizer 1, the vaporizer may be switched on manually, or automatically if at least one of the

detection units are pressed down and/or if the detection units are electronically connected with the consumable container surface 220. The positions of the resilient members are detected, in particular which ones of the resilient members of the vaporizer are retracted and/or if the detection units are electronically connected with the consumable container surface 220 (S101). The information coded by the consumable container surface 220 is decoded, e.g. by checking a table stored in a memory unit of the vaporizer against the result of the detection (S102, S 103). At least some of the decoded information may be indicated to the user by adjusting the intensity of the light color emitted by the LED light 110. E.g., the LED light 110 of figure 1 may be activated with a light with red intensified in colors, indicating a type A consumable container is connected, if a first and a second detecting units 101 are pressed down (retracted) or electronically connected, while the other detecting units 101 fit in the indentations 201 and remain in their projected position without touching the consumable container connecting surface (shown in figure 4a). As another example, the LED light 110 may be activated with a light with blue intensified in colors, indicating a type B consumable container is connected, if a third and a fourth detecting units 101 are pressed down or electronically connected, or a light with green intensified in colors, indicating a type C consumable container is connected, if a fifth and a sixth detecting units 101 are pressed down or electronically connected (S104). In all these cases, the vaporizer may be set up or configured in a mode which corresponds to the type of the consumable container.

[0045] In another embodiment of this invention, as shown in figure 4b together with figure 5 and based on the above embodiment, the retraction levels of resilient members are detected as well, i.e. how far the resilient members are pressed down (S101). The connected consumable container 2 is authenticated by checking if the protrusions 201 on the container connecting surface 220 connect and press the detecting units 101 in a predefined pattern. As shown in figure 4b, a first protrusion sticks out from the container connecting surface 220 by a first length so that a first detecting unit 101 is fully pressed down to its fully retracted position, and then outputs data "A" to the decoding unit. A second protrusion sticks out from the container connecting surface 220 by a second length so that a second detecting unit 101 is half-way pressed down to its half-way retracted position, and then outputs data "B". No protrusions are at the positions corresponding to a third and a fourth detecting units 101, the detecting units 101 are not pressed down and in their projected position, and then output data "C" (S102). It is determined if the connected consumable container 2 is authentic by checking if data "ABCC" represents consumable container 2 being authentic in a table stored in the vaporizer (S103). The operation of the vaporizer system 3 is activated if the consumable container is determined to be authentic (S104).

Claims

1. A vaporizer (1) configured to be connected to a consumable container (2) for vaporizing a consumable contained in the consumable container (2), a vaporizer connecting surface (120) of the vaporizer (1) being connected to a consumable container connecting surface (220) of the consumable container (2) when the vaporizer (1) is connected to the consumable container (2), wherein the vaporizer (1) comprises one or more detecting units (101) comprising a resilient member on the vaporizer connecting surface (120), on which the resilient member can take a projected or retracted position, configured to detect one or more aspects of the shape of the consumable container connecting surface (220) encoding information about the consumable container (2) by detecting whether or not or to which extent the resilient member is in a projected or retracted position when the vaporizer (1) is connected to the consumable container (2).
2. The vaporizer (1) according to the preceding claim, wherein the resilient member is configured to detect indentations and/or protrusions (201) arranged on a predetermined area of the consumable container connecting surface (220).
3. The vaporizer (1) according to the preceding claim, wherein the detecting units (101) is arranged on a main level and/or in a recess underneath the main level of the vaporizer connecting surface (120).
4. The vaporizer (1) according to the preceding claim, wherein the resilient member is configured to detect different depth and/or height levels of the indentations and/or protrusions (201).
5. The vaporizer (1) according to any one of the preceding claims, wherein the vaporizer (1) comprises a decoding unit configured to decode the information encoded by the one or more aspects of the shape of the consumable container connecting surface (220).
6. The vaporizer (1) according to any one of the preceding claims, wherein the resilient member is a pogo pin.
7. The vaporizer (1) according to the preceding claim, wherein further information is determined by detecting if the pogo pin is electronically connected with a conducting surface of the container.

8. The vaporizer (1) according to any one of the preceding claims, wherein the vaporizer (1) comprises an operation unit, which is configured to check a table stored in the vaporizer (1) against data obtained by detecting the one or more aspects of the shape of the consumable container connecting surface (220).
- 5 9. A consumable container (2) configured to be connected to a vaporizer (1) according to any one of the preceding claims and containing a consumable for being vaporized in the vaporizer (1), the consumable container (2) comprising a consumable container connecting surface (220) being connected to a vaporizer connecting surface (120) of the vaporizer (1) when the consumable container (2) is connected to the vaporizer (1), the shape of the consumable container connecting surface (220) having one or more aspects which encode information about the consumable container (2).
- 10 10. The consumable container (2) according to the preceding claim, wherein at least parts of the consumable container connecting surface (220) are made of a conductible material.
- 15 11. The consumable container (2) according to claims 9 or 10, wherein the one or more aspects of the shape of the consumable container connecting surface (220) comprises indentations and/or protrusions (201) at a predetermined area of the consumable container connecting surface (220).
- 20 12. The consumable container (2) according to the preceding claim, wherein the information is encoded by the presence of absence of indentations and/or protrusions (201) on the consumable container connecting surface (220), and/or the depth and/or height levels of the different indentations and/or protrusions (201).
- 25 13. A vaporizer system (3) comprising a vaporizer (1) according to any one of claims 1 to 8 and a consumable container (2) according to any one of claims 9 to 12.
- 30 14. A method of obtaining information about a consumable container (2) according to any one of claims 9 to 12, configured to be connected to a vaporizer (1) according to any one of claims 1 to 8, comprising the step of:
detecting which ones of the resilient members of the vaporizer (1) are pressed down and/or how far a resilient member is pressed down when the vaporizer (1) is connected to the consumable container (2),
decoding the information on the basis of the detection,
wherein the information is preferably decoded by checking a table stored in the vaporizer (1) against data obtained by the detection.
- 35 15. The method according claim 14, further comprising the step of indicating at least some of the obtained information to the user.

Patentansprüche

- 40 1. Verdampfer (1), der konfiguriert ist, um mit einem Verbrauchsbehälter (2) zum Verdampfen eines Verbrauchsmaterials, das in dem Verbrauchsbehälter (2) enthalten ist, verbunden zu werden, wobei eine Verdampferverbindungsfläche (120) des Verdampfers (1) mit einer Verbrauchsbehälterverbindungsfläche (220) des Verbrauchsbehälters (2) verbunden ist, wenn der Verdampfer (1) mit dem Verbrauchsbehälter (2) verbunden ist, wobei der Verdampfer (1) eine oder mehrere Erfassungseinheiten (101) umfasst, die ein spannkraftiges Element auf der Verdampferverbindungsfläche (120) umfassen, auf der das spannkraftige Element eine vorstehende oder zurückgezogene Position einnehmen kann, die konfiguriert ist, um einen oder mehrere Aspekte der Form der Verbrauchsbehälterverbindungsfläche (220) zu erfassen, die Informationen über den Verbrauchsbehälter (2) codiert, indem erfasst wird, ob oder in welchem Ausmaß sich das spannkraftige Element in einer vorstehenden oder zurückgezogenen Position befindet, wenn der Verdampfer (1) mit dem Verbrauchsbehälter (2) verbunden ist.
- 45 2. Verdampfer (1) nach dem vorhergehenden Anspruch, wobei das spannkraftige Element konfiguriert ist, um Vertiefungen und/oder Vorsprünge (201) zu erfassen, die auf einem vorbestimmten Bereich der Verbrauchsbehälterverbindungsfläche (220) angeordnet sind.
- 50 3. Verdampfer (1) nach dem vorhergehenden Anspruch, wobei die Erfassungseinheiten (101) auf einer Hauptebene und/oder in einer Aussparung unter der Hauptebene der Verdampferverbindungsfläche (120) angeordnet sind.
- 55

EP 3 984 385 B1

4. Verdampfer (1) nach dem vorhergehenden Anspruch, wobei das spannkraftige Element konfiguriert ist, um unterschiedliche Tiefen- und/oder Höhenebenen der Vertiefungen und/oder Vorsprünge (201) zu erfassen.
5. Verdampfer (1) nach einem der vorhergehenden Ansprüche, wobei der Verdampfer (1) eine Decodiereinheit umfasst, die konfiguriert ist, um die Informationen zu decodieren, die durch den einen oder die mehreren Aspekte der Form der Verbrauchsbehälterverbindungsfläche (220) codiert sind.
6. Verdampfer (1) nach einem der vorhergehenden Ansprüche, wobei das spannkraftige Element ein Pogostift ist.
10. Verdampfer (1) nach dem vorhergehenden Anspruch, wobei weitere Informationen durch Erfassen bestimmt werden, ob der Pogostift elektronisch mit einer leitenden Fläche des Behälters verbunden ist.
8. Verdampfer (1) nach einem der vorhergehenden Ansprüche, wobei der Verdampfer (1) eine Betriebseinheit umfasst, die konfiguriert ist, um eine in dem Verdampfer (1) gespeicherte Tabelle gegen Daten zu prüfen, die durch Erfassen des einen oder der mehreren Aspekte der Form der Verbrauchsbehälterverbindungsfläche (220) erhalten werden.
15. 9. Verbrauchsbehälter (2), der konfiguriert ist, um mit einem Verdampfer (1) nach einem der vorhergehenden Ansprüche verbunden zu werden, und der ein Verbrauchsmaterial enthält, um in dem Verdampfer (1) verdampft zu werden, wobei der Verbrauchsbehälter (2) eine Verbrauchsbehälterverbindungsfläche (220) umfasst, die mit einer Verdampferverbindungsfläche (120) des Verdampfers (1) verbunden ist, wenn der Verbrauchsbehälter (2) mit dem Verdampfer (1) verbunden ist, wobei die Form der Verbrauchsbehälterverbindungsfläche (220) einen oder mehrere Aspekte aufweist, die Informationen über den Verbrauchsbehälter (2) codieren.
20. 10. Verbrauchsbehälter (2) nach dem vorhergehenden Anspruch, wobei mindestens Teile der Verbrauchsbehälterverbindungsfläche (220) aus einem leitenden Material hergestellt sind.
25. 11. Verbrauchsbehälter (2) nach Anspruch 9 oder 10, wobei der eine oder die mehreren Aspekte der Form der Verbrauchsbehälterverbindungsfläche (220) Vertiefungen und/oder Vorsprünge (201) an einem vorbestimmten Bereich der Verbrauchsbehälterverbindungsfläche (220) umfassen.
30. 12. Verbrauchsbehälter (2) nach dem vorhergehenden Anspruch, wobei die Informationen durch das Vorhandensein oder Nichtvorhandensein von Vertiefungen und/oder Vorsprüngen (201) auf der Verbrauchsbehälterverbindungsfläche (220) und/oder die Tiefen- und/oder Höhenebenen der unterschiedlichen Vertiefungen und/oder Vorsprünge (201) codiert sind.
35. 13. Verdampfersystem (3), umfassend einen Verdampfer (1) nach einem der Ansprüche 1 bis 8 und einen Verbrauchsbehälter (2) nach einem der Ansprüche 9 bis 12.
40. 14. Verfahren zum Erhalten von Informationen über einen Verbrauchsbehälter (2) nach einem der Ansprüche 9 bis 12, der konfiguriert ist, um mit einem Verdampfer (1) nach einem der Ansprüche 1 bis 8 verbunden zu werden, umfassend den folgenden Schritt:

Erfassen, welche der spannkraftigen Elemente des Verdampfers (1) nach unten gedrückt werden und/oder wie weit ein spannkraftiges Element nach unten gedrückt wird, wenn der Verdampfer (1) mit dem Verbrauchsbehälter (2) verbunden ist,
Decodieren der Informationen auf der Basis der Erfassung,
wobei die Informationen vorzugsweise durch Prüfen einer in dem Verdampfer (1) gespeicherten Tabelle gegen Daten, die durch die Erfassung erhalten werden, decodiert werden.
50. 15. Verfahren nach Anspruch 14, ferner umfassend den Schritt des Anzeigens mindestens einiger der erhaltenen Informationen für den Benutzer.

Revendications

55. 1. Un vaporisateur (1) configuré pour être relié à un conteneur de consommable (2) pour vaporiser un consommable contenu dans le conteneur de consommable (2), une surface de liaison de vaporisateur (120) du vaporisateur (1) étant reliée à une surface de liaison de conteneur de consommable (220) du conteneur de consommable (2) lorsque

EP 3 984 385 B1

- le vaporisateur (1) est relié au conteneur de consommable (2), dans lequel le vaporisateur (1) comprend une ou plusieurs unités de détection (101) comprenant un organe élastique sur la surface de liaison de vaporisateur (120), sur laquelle l'organe élastique peut prendre une position saillante ou rétractée, configurées pour détecter une ou plusieurs aspects de la forme de la surface de liaison de conteneur de consommable (220) qui codent une information relative au conteneur de consommable (2), par détection si l'organe élastique est ou non, ou dans quelle proportion, dans une position saillante ou rétractée lorsque le vaporisateur (1) est relié au conteneur de consommable (2).
- 5
2. Le vaporisateur (1) selon la revendication précédente, dans lequel l'organe élastique est configuré pour détecter des indentations et/ou des reliefs (201) agencés sur une zone prédéterminée de la surface de liaison de conteneur de consommable (220).
- 10
3. Le vaporisateur (1) selon la revendication précédente, dans lequel les unités de détection (101) sont agencées sur un niveau principal et/ou dans un creux au-dessous du niveau principal de la surface de liaison de vaporisateur (120) .
- 15
4. Le vaporisateur (1) selon la revendication précédente, dans lequel l'organe élastique est configuré pour détecter des niveaux différents de profondeur et/ou de hauteur des indentations et/ou des reliefs (201).
5. Le vaporisateur (1) selon l'une des revendications précédentes, dans lequel le vaporisateur (1) comprend une unité de décodage configurée pour détecter l'information codée par les un ou plusieurs aspects de la forme de la surface de liaison de conteneur de consommable (220).
- 20
6. Le vaporisateur (1) selon l'une des revendications précédentes, dans lequel l'organe élastique est une broche Pogo.
7. Le vaporisateur (1) selon la revendication précédente, dans lequel en outre une information est déterminée en détectant si la broche Pogo est électroniquement reliée à une surface conductrice du conteneur.
- 25
8. Le vaporisateur (1) selon l'une des revendications précédentes, dans lequel le vaporisateur (1) comprend une unité opérationnelle, qui est configurée pour rechercher dans une table stockée dans le vaporisateur (1) des données obtenues par détection des un ou plusieurs aspects de la forme de la surface de liaison de conteneur de consommable (220).
- 30
9. Un conteneur de consommable (2) configuré pour être relié à un vaporisateur (1) selon l'une des revendications précédentes et contenant un consommable destiné à être vaporisé dans le vaporisateur (1), le conteneur de consommable (2) comprenant une surface de liaison de conteneur de consommable (220) qui est reliée à une surface de liaison de vaporisateur (120) du vaporisateur (1) lorsque le conteneur de consommable (2) est relié au vaporisateur (1), la forme de la surface de liaison de conteneur de consommable (220) possédant un ou plusieurs aspects qui codent une information relative au conteneur de consommable (2).
- 35
10. Le conteneur de consommable (2) selon la revendication précédente, dans lequel au moins des parties de la surface de liaison de conteneur de consommable (220) sont réalisées en un matériau pouvant être conducteur.
- 40
11. Le conteneur de consommable (2) selon les revendications 9 ou 10, dans lequel les un ou plusieurs aspects de la forme de la surface de liaison de conteneur de consommable (220) comprennent des indentations et/ou des reliefs (201) sur une zone prédéterminée de la surface de liaison de conteneur de consommable (220).
- 45
12. Le conteneur de consommable (2) selon la revendication précédente, dans lequel l'information est codée par la présence ou l'absence d'indentations et/ou de reliefs (201) sur la surface de liaison de conteneur de consommable (220), et/ou par les niveaux de profondeur et/ou de hauteur des différentes indentations et/ou reliefs (201).
- 50
13. Un système de vaporisateur (3) comprenant un vaporisateur selon l'une des revendications 1 à 8 et un conteneur de consommable selon l'une des revendications 9 à 12.
14. Un procédé d'obtention d'une information relative à un conteneur de consommable (2) selon l'une des revendications 9 à 12, configuré pour être relié à un vaporisateur (1) selon l'une des revendications 1 à 8, comprenant les étapes de :
- 55
- détection de ceux des organes élastiques du vaporisateur (1) qui sont enfoncés, et/ou du degré auquel un organe élastique est enfoncé, lorsque le vaporisateur (1) est relié au conteneur de consommable (2), et le décodage de l'information sur la base de la détection,

EP 3 984 385 B1

dans lequel l'information est de préférence décodée par confrontation d'une table stockée dans le vaporisateur (1) avec les données obtenues par la détection.

- 5 **15.** Le procédé selon la revendication 14, comprenant en outre l'étape d'indication à l'utilisateur d'au moins certaines des informations obtenues.

10

15

20

25

30

35

40

45

50

55

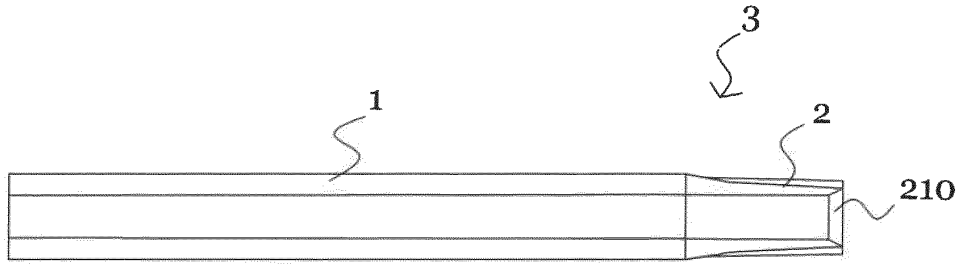

Fig. 1a

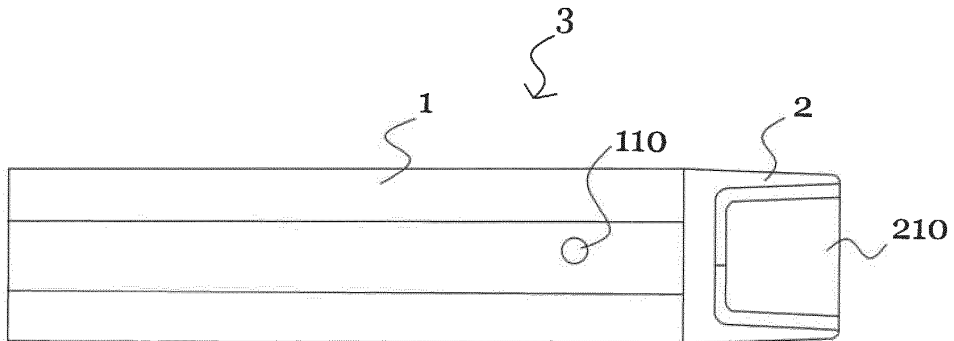

Fig. 1b

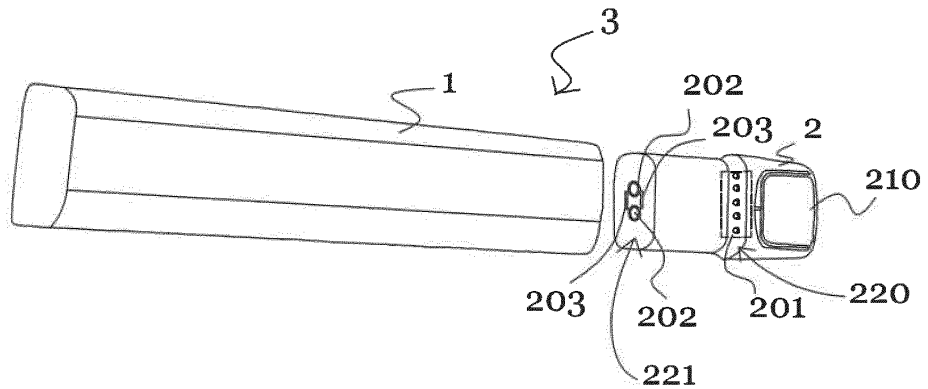
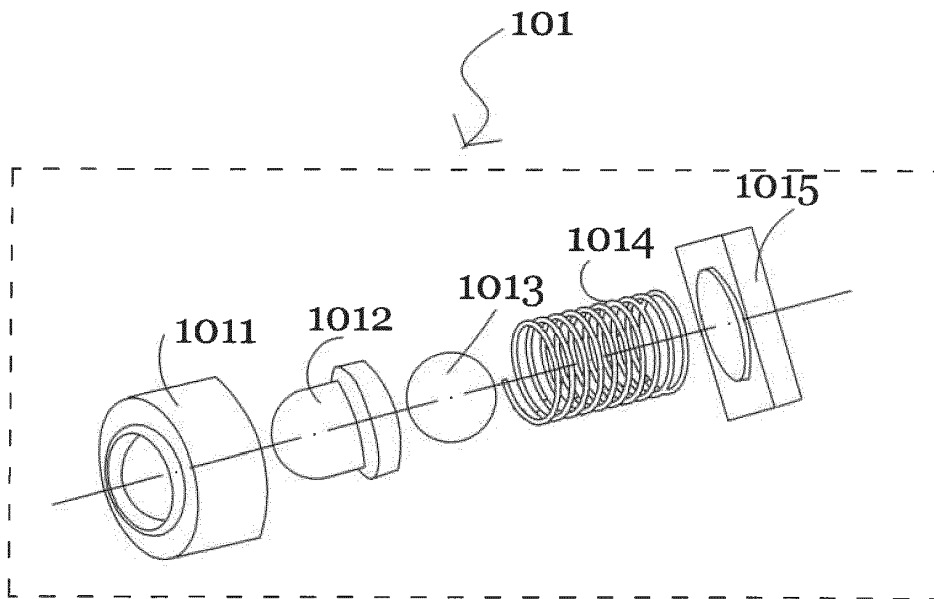
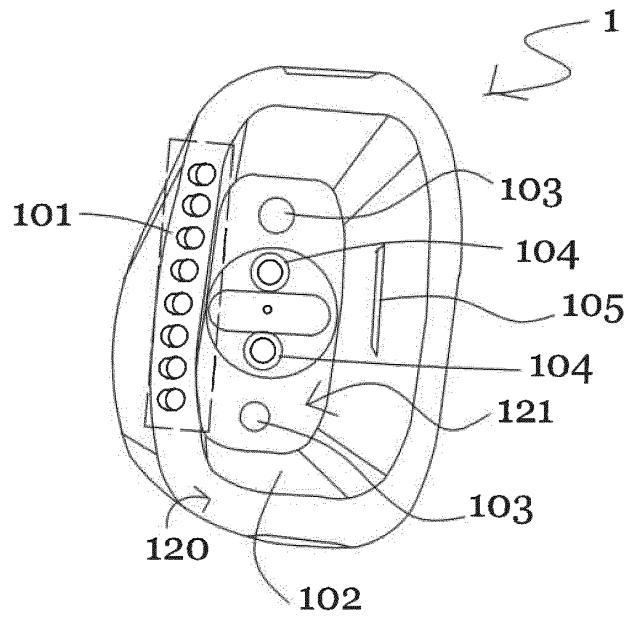
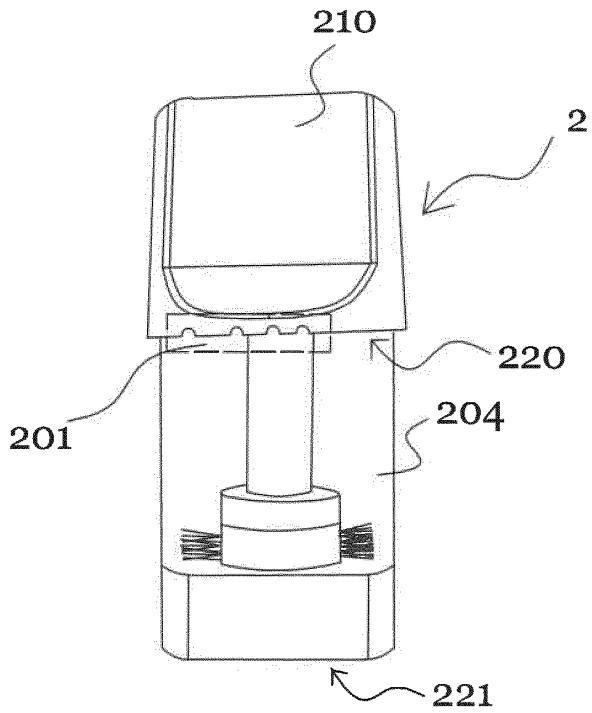

Fig. 1c



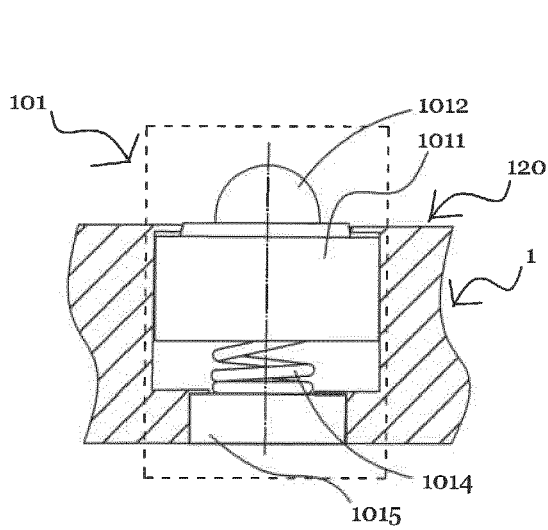

Fig. 3a

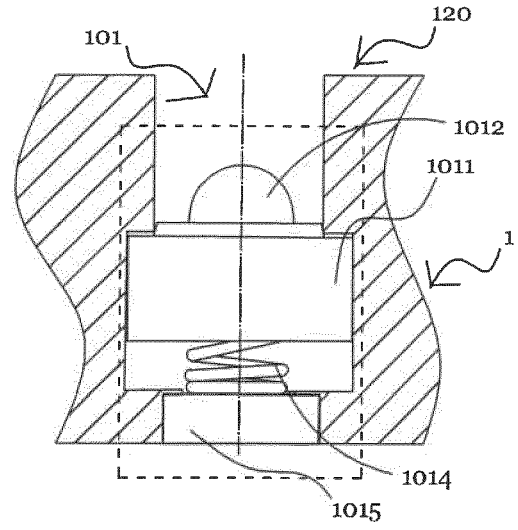

Fig. 3b

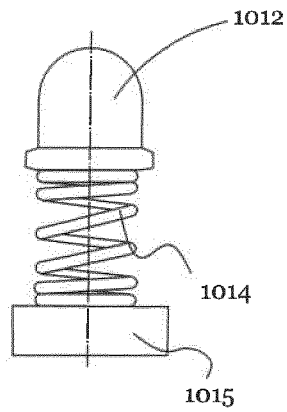

Fig. 3c

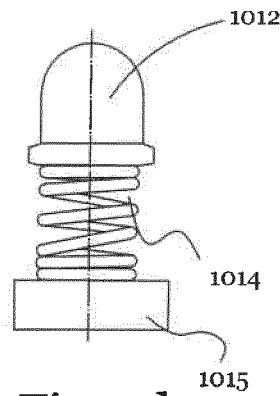

Fig. 3d

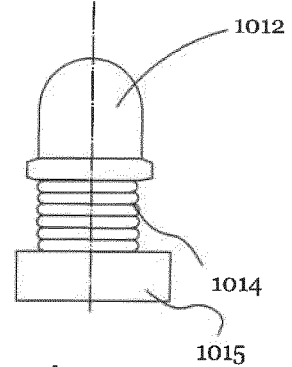

Fig. 3e

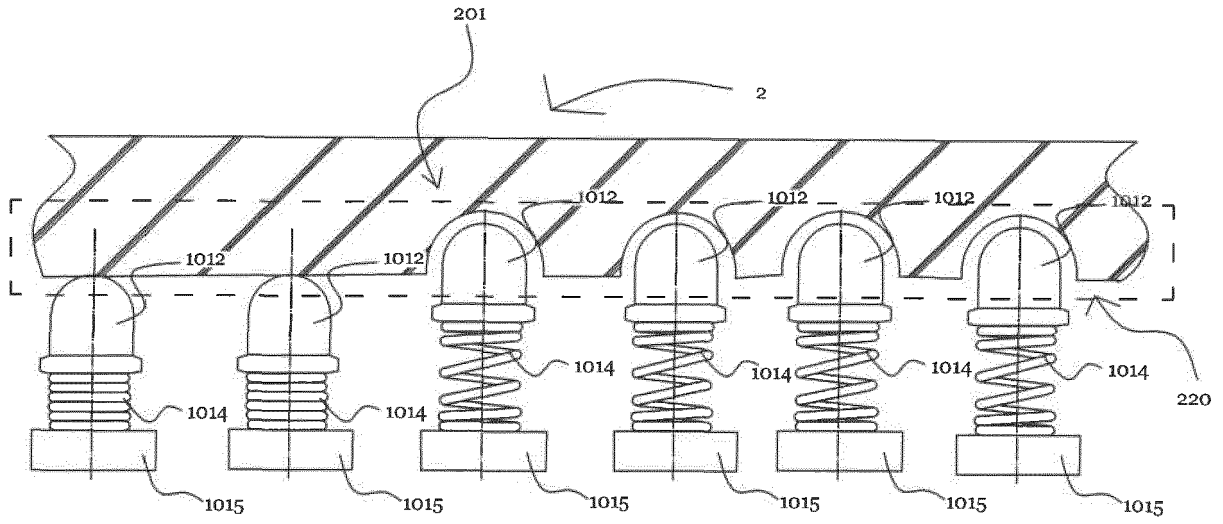

Fig. 4a

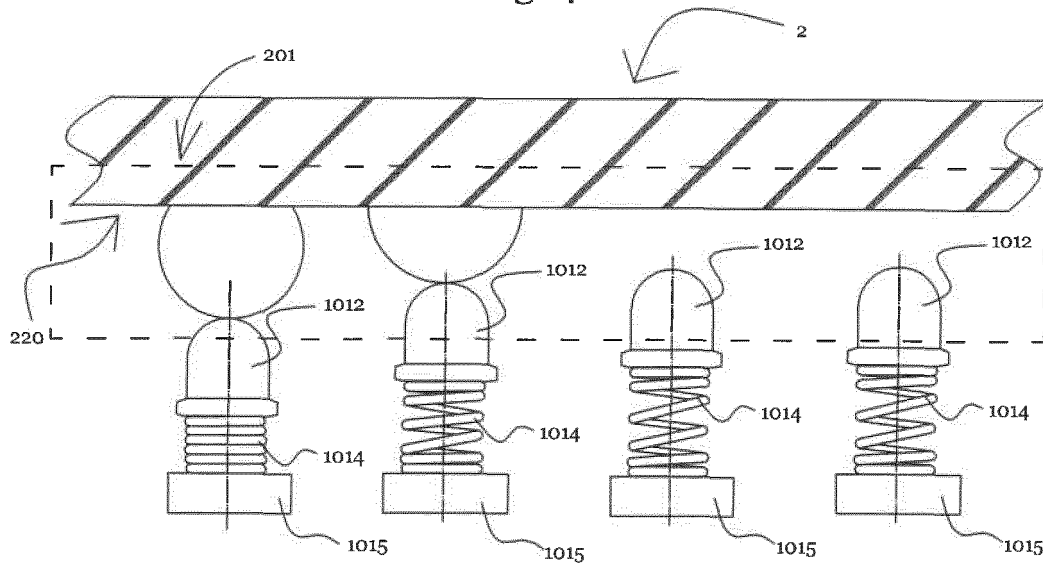

Fig. 4b

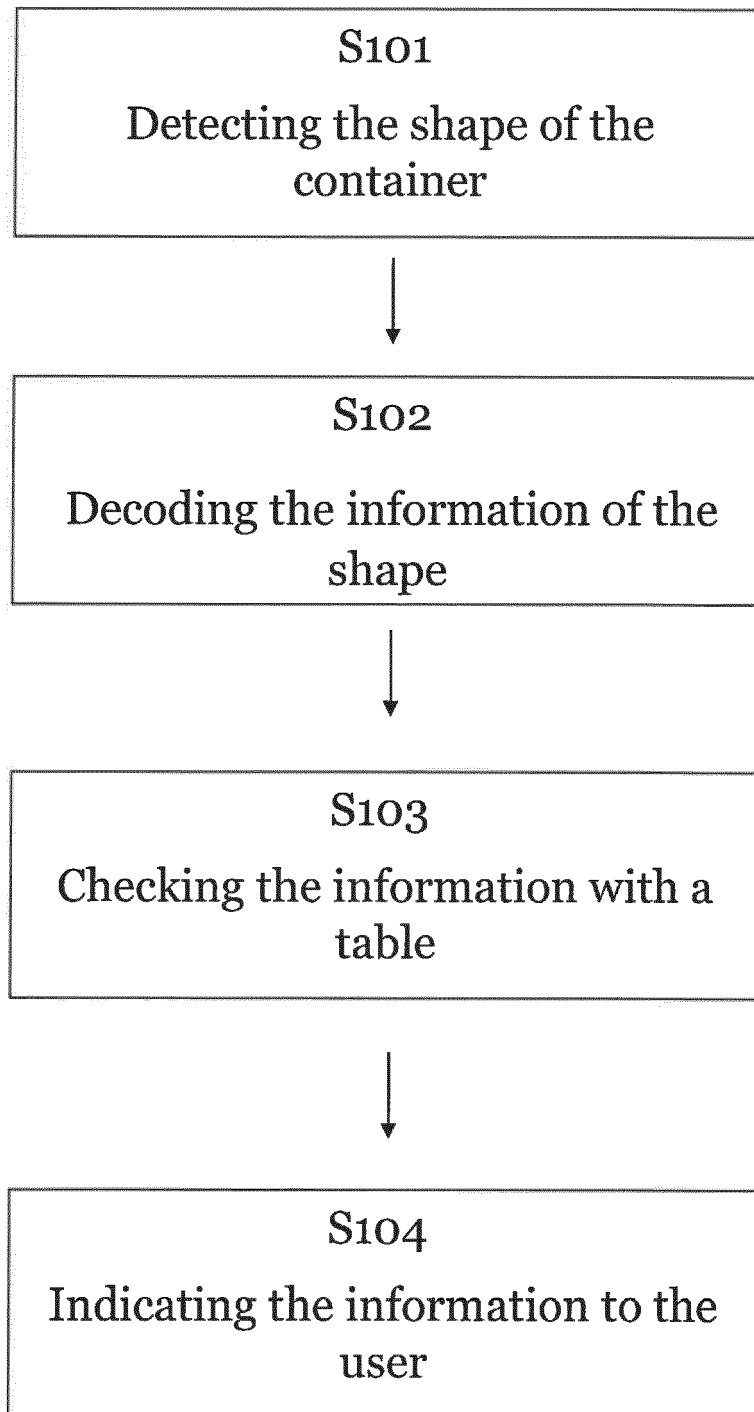

Fig. 5

REFERENCES CITED IN THE DESCRIPTION

This list of references cited by the applicant is for the reader's convenience only. It does not form part of the European patent document. Even though great care has been taken in compiling the references, errors or omissions cannot be excluded and the EPO disclaims all liability in this regard.

Patent documents cited in the description

- CN 11095991 A [0005]
- WO 2019129866 A [0005]