

(No Model.)

3 Sheets—Sheet 1.

S. F. VAN CHOATE.
ELECTRIC ARC LAMP.

No. 268,155.

Patented Nov. 28, 1882.

Fig. 1.

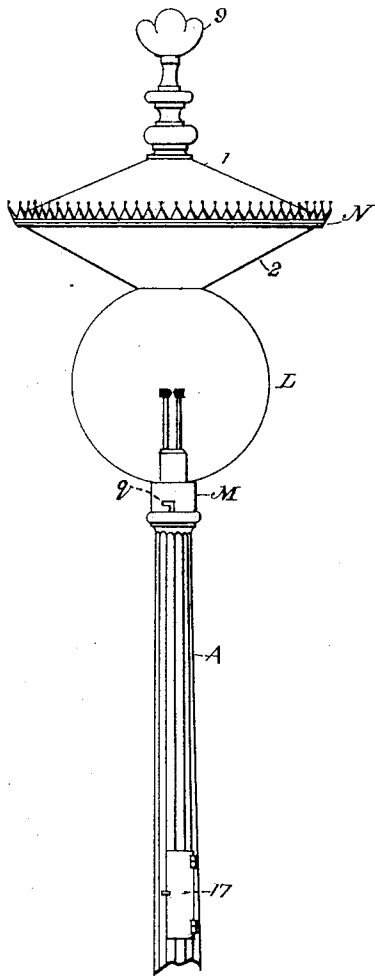
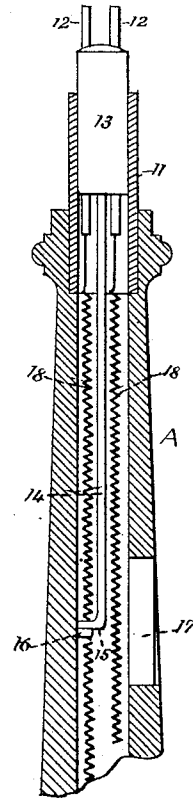

Fig. 5.



ATTEST:

Julian H. Burdette.
Chas O'Neil

INVENTOR:

S. F. Van Choate
By H. C. Townsend
Atty.

S. F. VAN CHOATE.

ELECTRIC ARC LAMP.

No. 268,155.

Patented Nov. 28, 1882.

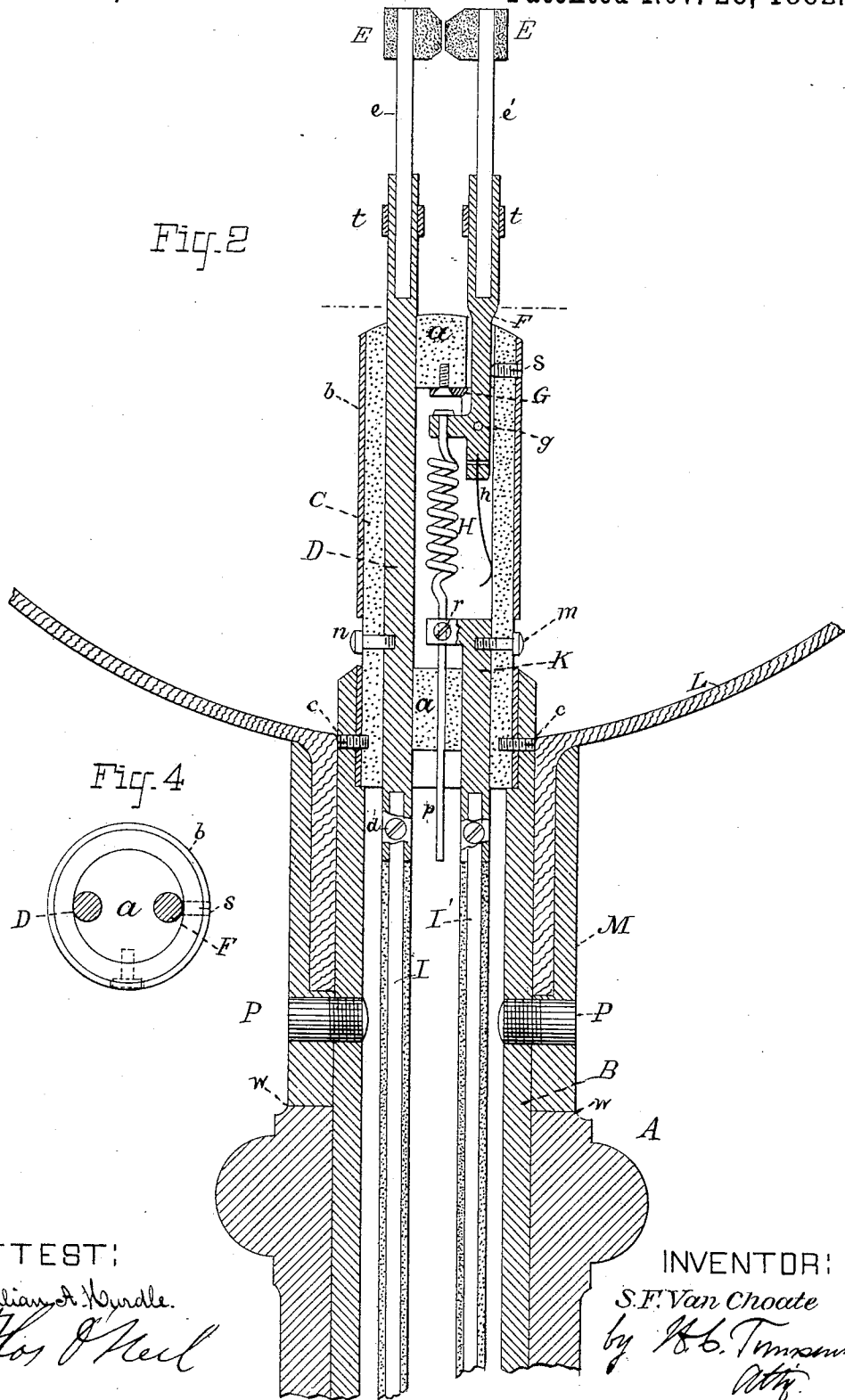

ATTEST:

Julian A. Hyde.
Chas. J. Keil

INVENTOR:

S. F. Van Choate
by *H. B. Townsend*
Atty.

S. F. VAN CHOATE.

ELECTRIC ARC LAMP.

No. 268,155.

Patented Nov. 28, 1882.

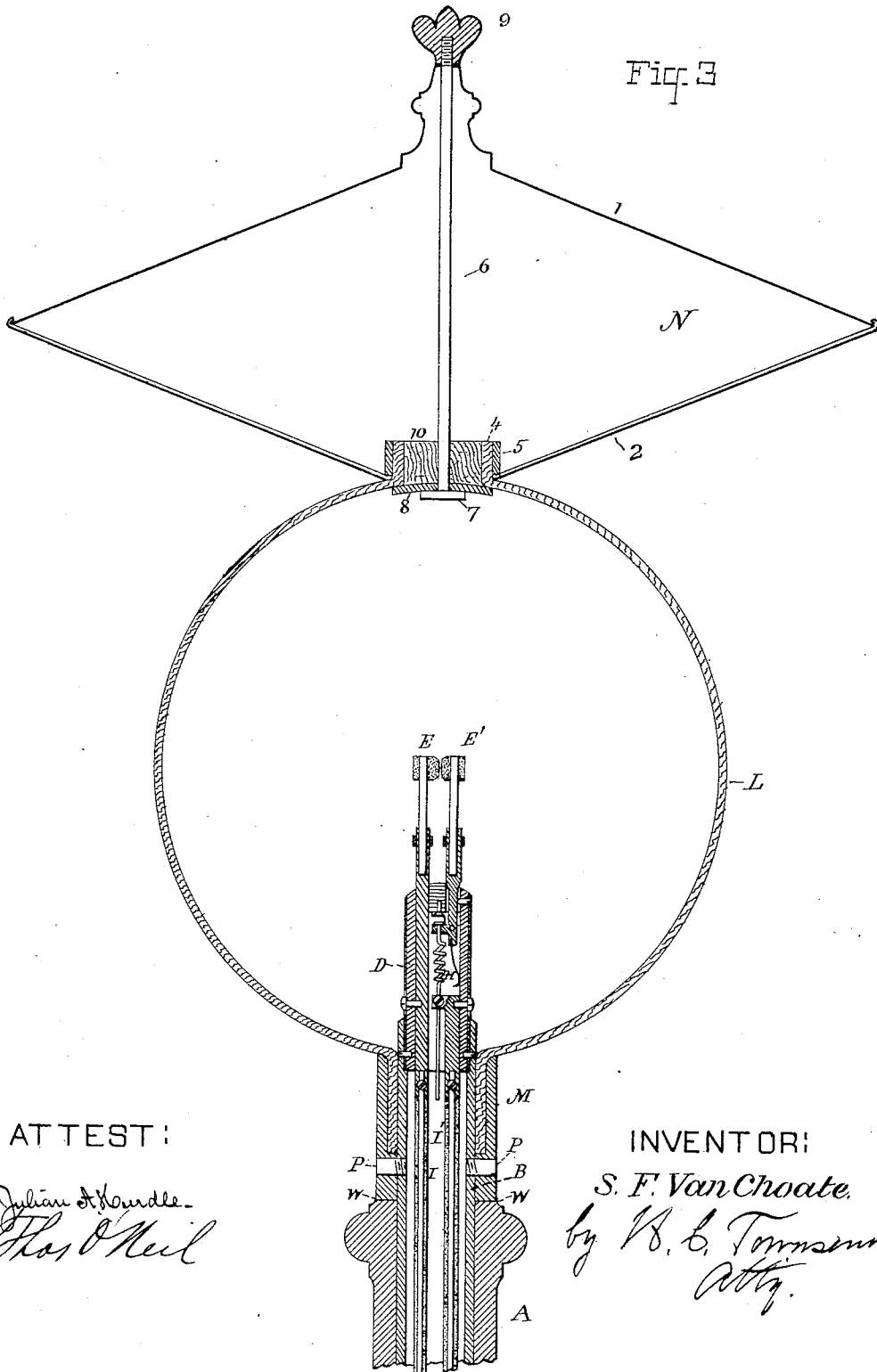

ATTEST:

Julian S. Hurdle.
Thos. Neil

INVENTOR:

S. F. Van Choate.
by W. B. Townsend
Atty.

UNITED STATES PATENT OFFICE.

SILVANUS F. VAN CHOATE, OF NEW YORK, N. Y.

ELECTRIC-ARC LAMP.

SPECIFICATION forming part of Letters Patent No. 268,155, dated November 28, 1882.

Application filed June 1, 1881. (No model.)

To all whom it may concern:

Be it known that I, SILVANUS F. VAN CHOATE, a citizen of the United States, residing at New York, in the county of New York and State of New York, have invented new and useful Improvements in Electric-Arc Lamps, of which the following is a specification.

The general object of my invention is to produce a simple, compact, and durable electric lamp, suitable for either outdoor or indoor use, without the employment of clock-work regulators and electro-magnetic devices, and to dispense with all parts or attachments which in lights of the arc type obscure the light and produce shadows.

My invention consists, first, in certain novel devices for forming and determining the length of arc between two pieces of refractory material whose rate of consumption is so slow as not to require an adjustment of the pieces toward one another during the time for which the light is ordinarily required to burn without intermission; second, in an improved construction of the supporting parts, applicable in some features not only to arc-lamps employing a refractory non-volatilizable material, but also to those in which a strip or rod of high electrical resistance, heated to incandescence by the passage of the current, is used.

In the accompanying drawings, Figure 1 is an elevation of my lamp mounted upon a post. Fig. 2 is an enlarged vertical section of the lamp proper. Fig. 3 is a vertical section, drawn to another scale, of the complete lamp with its hood and reflector, showing the means employed for securing the reflector to the globe surrounding the light. Fig. 4 is a top view of the support or holder in which are contained the supporting-rods or conductors leading to the electrodes. Fig. 5 is a sectional view of a modification.

A represents a hollow post, of cast-iron or other suitable material, upon which the lamp is mounted.

Within the upper part of the post is a cylinder or tube of brass, B, secured in place by screws or bolts passing through the hollow post and into the tube.

Entering the upper part of the tube B, and secured therein by screws *c*, is a tube of insu-

lating material, C, surrounded with a thin supporting-cylinder, *b*, of brass or other metal, at whose upper and lower ends are insulating-plugs, *a a*, secured by screws passing through the tube C, in the manner shown in Fig. 4.

A conducting-rod of copper, D, passing through both plugs and secured by a screw, *n*, terminates at its upper end in a spring-socket, while its lower end extends below the plug *a*, and is also provided with a socket and a binding-screw, *d*, for the reception of an insulated conducting-wire, I, which conveys the electricity to or from the light. The spring-socket upon the upper end of D holds one of the electrodes of the light, said electrode consisting in the present case of a copper wire or pin, *e*, to the upper end of which is secured, by riveting or otherwise, a block of any suitable refractory material, E, between which and a similar block, E', the electric arc is formed. This material may be an alloy of arsenicum, copper, and chloride of sodium, in the proportion of two to three parts of arsenic, five to six parts of copper, and a suitable proportion of chloride of sodium, combined by heat in a closed crucible, after the manner described in an application for Letters Patent of the United States filed by me April 18, 1881, No. 31,143.

The block E' is secured to a copper pin or wire, which is seated in a spring-socket formed in the upper end of a rocking elbow-lever, F, pivoted or fulcrumed at *g* in a bracket, G, secured to the lower side of the upper plug, *a*. A flat spring, *h*, secured in the lower end of the lever F, and bearing upon the inner side of the insulating-tube C, tends to swing the lever so as to separate the electrodes E and E'. When the lamp is not in use, and before the current is turned on, this tendency on the part of the spring *h* is overcome by the action of a stout spring, H, of suitable metal—such as brass—which fits tightly in a perforation in the short arm of the lever F, and is riveted or flattened at its upper end, so that it may exert a downward pull upon the arm. The other end passes through and is clamped in a lug projecting from a conducting-rod, K, secured in place by a screw, *r*. The rod K, like D, passes through the lower plug, *a*, and is provided at its lower end with a socket and clamp-screw

for the reception of one of the conducting-wires I. Spring H may be adjusted to any desired tension by means of its extension *p* and the screw *r*. The spring H serves not only to
 5 bring the electrodes into contact, but also to complete the circuit between the lever F and the lower conducting-rod, K. When no current is passing its tension is sufficient to overcome the strength of spring *h*, and thus hold
 10 the electrodes in contact. When, however, the current passes it is heated and lengthens, so as to cease acting upon the lever, and at the same time allow the weaker spring, *h*, which is not in the electrical circuit, to act and separate the electrodes so as to form the arc. The
 15 distance to which the electrodes shall be separated is determined by the adjustable stop-screw *s*, against which the lever F is thrown by the action of the smaller spring. The sockets in the upper end of the holders D and F
 20 are made to grasp the electrodes firmly by splitting or sawing them longitudinally, while sliding collars *t*, of brass or other suitable material, which may be moved up and down, serve to more securely hold the wires *e e'* in place. The burners E and E' are secured to the ends of the pins *e* and *e'* by swaging the tops of the pins, thus making good contact. They may be of any suitable material which is highly refractory and consumes but slowly under the action of the arc. The spring sockets or holders D and F allow of a ready and convenient replacement of the burners and make good electrical connection.
 30 A globe, L, of translucent material, surrounds the light proper, and is formed with a neck at its bottom, ground to fit in a sleeve, M, of brass or other suitable material, within which it is secured by cement or otherwise. This sleeve is slotted, in the manner shown in Fig. 1 at *q*, upon diametrically-opposite sides, after the manner of a bayonet-joint, and locks upon pins P P, projecting from the tube B. As shown in Fig. 2, the lower edge of the cylinder M,
 45 when the globe is in place, is seated closely upon a step or shoulder, *w*, upon the post A, thus effectually excluding dirt and dust from the globe.
 For the purpose of utilizing the rays from the
 50 light which would otherwise pass upward and be lost, I attach to the upper part of the globe a conical reflector and hood, N. The reflector 2 is placed with its apex downward, so as to effectually diffuse the light-rays in the proper directions, and is secured at its larger end to an ornamental cap-piece of sheet metal. The configuration of these various parts forms the subject of a Design Patent filed of even date herewith. The hood and reflector are secured to
 60 the globe by the devices shown in Fig. 3. The conical reflector 2 is hollow and is truncated. Its truncated portion is seated upon and embraces the upper portion of the globe, which is itself perforated at the top, and provided with an upwardly-projecting neck, 4, which is embraced by a metallic collar, 5, secured to

the inside of the opening in the reflector. A bolt, 6, between the headed end of which and the inner surface of the globe is interposed a washer, 8, of some suitable material like copper, to form an extended bearing-surface for
 70 the bolt upon the inner surface of the globe, passes upward through the neck, while an ornamental screw-nut, 9, resting upon the upper portion of the hood or cap-piece 1, engages
 75 with a screw-thread upon the upper end of the bolt and serves to hold the parts firmly together. A plug, 10, of suitable material, surrounds the bolt at the point where it passes through the neck and serves to keep the rod
 80 in a central position.

By the above construction it will be seen that I dispense entirely with the use of supporting arms or rods about the globe, which tend to obscure the light and produce shadows.
 85 In this respect the construction of the supports for the electrodes and the light proper, as shown in Figs. 2 and 3, possesses advantages, as it is very compact and does not obscure the light and produces shadows in a downward
 90 direction.

It is obvious that the construction of the holder or support for the electrodes herein described may be used with advantage for incandescent electric lights. In such case the
 95 incandescent portion of the light would consist simply of an inverted-U or other desirable shaped piece of refractory conducting material seated in the upper spring-sockets. In the latter case the parts employed for separating and adjusting the electrodes would not be necessary, and F could be of the same construction and would be supported in the same way as the rod and socket D. It is obvious that the various parts may be supported in a
 105 bracket instead of upon a post.

Fig. 5 is a sectional elevation, showing the manner in which my lamp is constructed when it is desired to avoid the use of a ladder, or the removal of the translucent globe and hood
 110 when the burners of the lamp are to be renewed or repaired, or when the spring is to be adjusted. In this figure, A is the hollow cast-iron or other support. 11 is a metallic tube fitted into the top of post A, and serving
 115 as the finishing or terminal casing of carriers or sockets 12; and the case or cylinder 13 is a round tube of suitable metal or material carrying or containing the mechanisms which insulate and regulate the terminals or burners
 120 of the lamp. The tube or case corresponds to the tube C *b* in Fig. 2, except that it is not secured to the tube 11, corresponding to B, Fig. 2, by screw-pins, but is so constructed as to slide or move up and down freely in the
 125 hollow formed in the tube and post.

A rod or projecting tang, 14, is connected to the movable case 13, and extends downward within the hollow of the post sufficiently to be within reach of a person when standing on the
 130 sidewalk. At the lower extremity of handle or tang 14 is a fixture or projection, 15, which,

upon turning the tang to one side, can be held in position by a fixture or projection, 16, attached to the post A. At or near the point where the projection 16 and lower end of the tang are located is a door or opening, 17, in the side of the post, and by the opening of which the tang or rod can be unlocked and lowered at pleasure, so as to bring down the case and the burners of the lamp to a point opposite the opening in the post, and in such a manner that the burners of the lamp can be inserted and the spring adjusted, replaced, or repaired without removing the globe or hood at the top of the post. The wires 18 18, forming the conductors of the lamp, are flexible, so as to allow the free movement of the cylinder 13 up and down in the lamp.

I am aware that it is not new to employ a straight rigid expansible piece for holding the electrodes together in the same way as the spiral spring herein described, and I therefore make no claim to such a construction. By the employment of a spring I am enabled to more readily adjust the lamp, and the action is more delicate and prompt.

What I claim as my invention is—

1. The combination, substantially as described, of the insulating-tube C, with its plugs *a a*, rod D, the pivoted lever F, conducting-spring H, and spring *h*, the two latter for adjusting the electrodes and conveying the current thereto.

2. The combination, with the movable holder, of two springs acting in opposition to one another upon the holder, one of said springs serving to convey the current to the electrodes and when not acted upon by the current to hold them in contact, and the other weaker than the first, but acting when the first spring is elongated by the heating effects of the current to separate the electrodes and form the arc.

3. The combination, substantially as described, of a stationary and a movable electrode of refractory material, a spring acting upon the movable electrode and tending to

separate the electrodes to form the arc, a spiral conducting-spring acting upon the same electrode, and tending, when not heated by the current, to force the electrodes into contact, and an adjustable stop for determining the amount of separation of the electrodes.

4. The combination, with the rocking holder G, carrying one of the refractory electrodes, of the conducting spiral spring H, fixed at one end to a stationary support and connected at the other to the rocking holder, said spring being applied, in the manner described, so as to tend, when cold, to pull the electrode toward its opposite electrode, and when heated by the passage of the current through it to relax so as to allow the electrodes to be separated.

5. The combination, with the movable holder carrying one of the refractory electrodes, of an adjustable spiral actuating-spring, forming a path for the current, and tending, when cold, to hold the electrodes together, and means for separating the electrodes when the spiral spring is relaxed by the heating effects of the current passing through it.

6. The combination of the hollow post, provided with a door or opening with the tube or plug 13, supporting the light and adapted to slide up and down in said post, and means whereby the tube or plug may be held in a raised position.

7. The combination of the hollow post, provided with a door or opening, with a carrier or support for the operating parts of the light, and means, substantially as described, whereby said carrier may be raised and lowered or held in a raised position, substantially as described.

8. The combination, with the carrier or support 13 for the operating parts of the lamp, of the tang or rod 15 and the step or support 16, substantially as and for the purpose described.

SILVANUS F. VAN CHOATE.

Witnesses:

JOHN J. DIFFLEY,
H. C. TOWNSEND.