

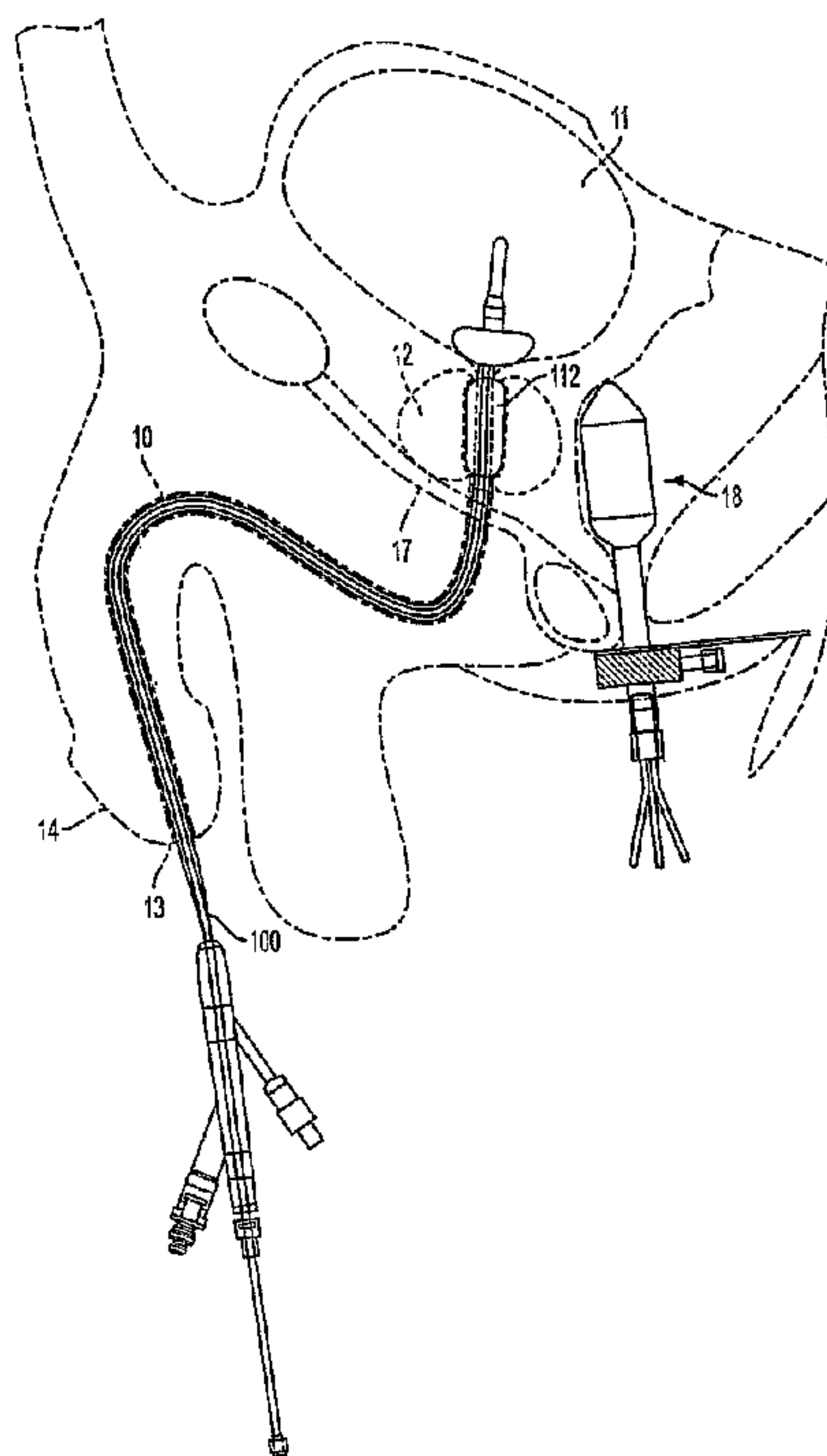

(86) Date de dépôt PCT/PCT Filing Date: 2003/02/19  
 (87) Date publication PCT/PCT Publication Date: 2003/08/28  
 (45) Date de délivrance/Issue Date: 2013/04/23  
 (85) Entrée phase nationale/National Entry: 2004/08/11  
 (86) N° demande PCT/PCT Application No.: US 2003/004512  
 (87) N° publication PCT/PCT Publication No.: 2003/070298  
 (30) Priorités/Priorities: 2002/02/15 (US60/356,750);  
 2002/09/13 (USPCT/US02/29048)

(51) Cl.Int./Int.Cl. *A61B 18/04* (2006.01),  
*A61F 7/12* (2006.01), *A61N 5/04* (2006.01)  
 (72) Inventeurs/Inventors:  
 MON, JOHN, US;  
 FENN, ALAN J., US  
 (73) Propriétaire/Owner:  
 MEDIFOCUS, INC., US  
 (74) Agent: SIM & MCBURNEY

(54) Titre : PROCEDE ET APPAREIL DE TRAITEMENT DE TISSUS PROCHES D'UN CONDUIT CORPOREL PAR THERMOCOMPRESSIION ET ADMINISTRATION DE MEDICAMENTS  
 (54) Title: METHOD AND APPARATUS TREATING TISSUE ADJACENT A BODILY CONDUIT WITH THERMOCOMPRESSIION AND DRUGS



(57) **Abrégé/Abstract:**

A method and apparatus (100) of treating tissue adjacent a bodily conduit using thermotherapy, while preventing obstructions of the bodily conduit due to edema, includes injection of a drug-encapsulated within a heat-sensitive carrier, such as a liposome, within a region of tissue to be treated. The heat produced by the energy-emitting source (110) heats a portion of the tissue surrounding the bodily conduit to a temperature of approximately 43 °C for a time sufficient to destroy the heated portion of the tissue. In addition, the heat produced by the energy-emitting source (110) activates the heat-sensitive carrier to activate the release of the encapsulated drug and the drug targets the tissue to be heated. The focused energy of the energy-emitting source together with the compression acting on the target area can assist in delivering drugs to the target area so that a natural stent has a long term efficacy.

(12) INTERNATIONAL APPLICATION PUBLISHED UNDER THE PATENT COOPERATION TREATY (PCT)

(19) World Intellectual Property  
Organization  
International Bureau



(43) International Publication Date  
28 August 2003 (28.08.2003)

PCT

(10) International Publication Number  
**WO 2003/070298 A3**

(51) International Patent Classification<sup>7</sup>: **A61B 18/04**

[US/US]; 14712 Locustwood Avenue, Silver Spring, MD 20905 (US). FENN, Alan, J. [US/US]; 4 Sherman Bridge Road, Wayland, MA 01778 (US).

(21) International Application Number:  
PCT/US2003/004512

(22) International Filing Date: 19 February 2003 (19.02.2003)

(25) Filing Language: English

(26) Publication Language: English

(30) Priority Data:  
60/356,750 15 February 2002 (15.02.2002) US  
PCT/US02/29048  
13 September 2002 (13.09.2002) US

(71) Applicant (for all designated States except US): **CELSION CORPORATION** [US/US]; 10220-I Old Columbia Road, Columbia, MD 21046 (US).

(72) Inventors; and

(75) Inventors/Applicants (for US only): **MON, John**

(74) Agent: **VOORHEES, Catherine, M.**; Venable, Baetjer, Howard & Civiletti, LLP, 1201 New York Avenue, NW, Suite 1000, P.O. Box 34385, Washington, DC 20043-9998 (US).

(81) Designated States (*national*): AE, AG, AL, AM, AT, AU, AZ, BA, BB, BG, BR, BY, BZ, CA, CH, CN, CO, CR, CU, CZ, DE, DK, DM, DZ, EC, EE, ES, FI, GB, GD, GE, GH, GM, HR, HU, ID, IL, IN, IS, JP, KE, KG, KP, KR, KZ, LC, LK, LR, LS, LT, LU, LV, MA, MD, MG, MK, MN, MW, MX, MZ, NO, NZ, OM, PH, PL, PT, RO, RU, SC, SD, SE, SG, SK, SL, TJ, TM, TN, TR, TT, TZ, UA, UG, US, UZ, VC, VN, YU, ZA, ZM, ZW.

(84) Designated States (*regional*): ARIPO patent (GH, GM, KE, LS, MW, MZ, SD, SL, SZ, TZ, UG, ZM, ZW), Eurasian patent (AM, AZ, BY, KG, KZ, MD, RU, TJ, TM),

[Continued on next page]

(54) Title: METHOD AND APPARATUS TREATING TISSUE ADJACENT A BODILY CONDUIT WITH THERMOCOMPRESSSION AND DRUGS

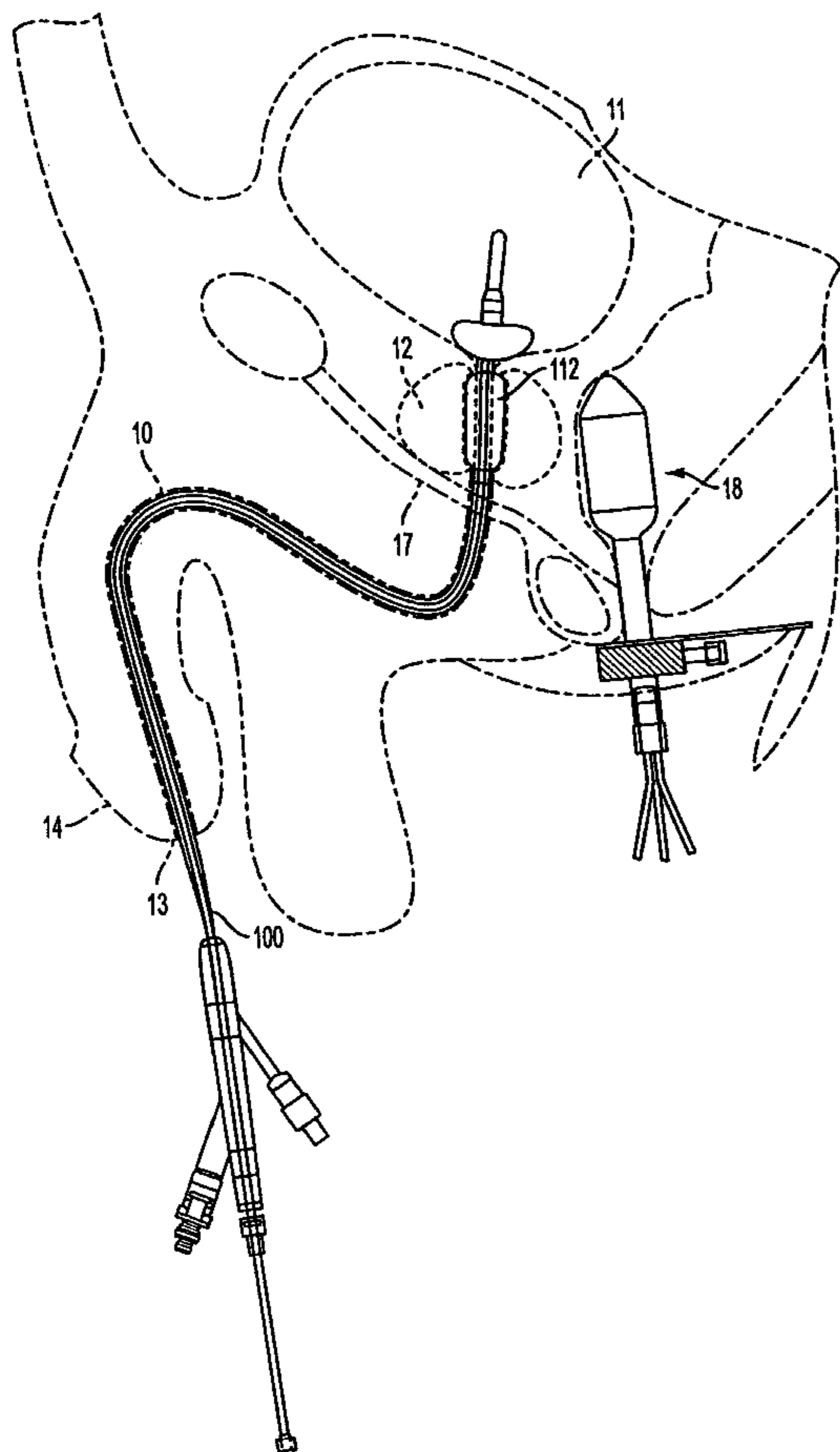

(57) Abstract: A method and apparatus (100) of treating tissue adjacent a bodily conduit using thermotherapy, while preventing obstructions of the bodily conduit due to edema, includes injection of a drug-encapsulated within a heat-sensitive carrier, such as a liposome, within a region of tissue to be treated. The heat produced by the energy-emitting source (110) heats a portion of the tissue surrounding the bodily conduit to a temperature of approximately 43 °C for a time sufficient to destroy the heated portion of the tissue. In addition, the heat produced by the energy-emitting source (110) activates the heat-sensitive carrier to activate the release of the encapsulated drug and the drug targets the tissue to be heated. The focused energy of the energy-emitting source together with the compression acting on the target area can assist in delivering drugs to the target area so that a natural stent has a long term efficacy.

WO 2003/070298 A3

**WO 2003/070298 A3**



European patent (AT, BE, BG, CH, CY, CZ, DE, DK, EE, ES, FI, FR, GB, GR, HU, IE, IT, LU, MC, NL, PT, SE, SI, SK, TR), OAPI patent (BF, BJ, CF, CG, CI, CM, GA, GN, GQ, GW, ML, MR, NE, SN, TD, TG).

**(88) Date of publication of the international search report:**

12 February 2004

**Published:**

— *with international search report*

*For two-letter codes and other abbreviations, refer to the "Guidance Notes on Codes and Abbreviations" appearing at the beginning of each regular issue of the PCT Gazette.*

# METHOD AND APPARATUS TREATING TISSUE ADJACENT A BODILY CONDUIT WITH THERMOCOMPRESSSION AND DRUGS

[001]

5

## Background of the Invention

### 1. Field of the Invention

[002] The present invention generally relates to a system and method for administering  
focused energy to a body using either a single energy applicator or multiple microwave  
applicators, warmed fluid and compression in order to treat visible tumors and microscopic  
10 malignant and benign cells in tissue with thermotherapy. In particular, the present  
invention relates to a transurethral catheter for microwave thermal and warming therapy  
with compression of prostate tissue adjacent a urethra to create a biological stent.

### 2. Description of the Prior Art

[003] In order to treat the prostate with thermotherapy, it is necessary to heat a significant  
15 portion of the prostate gland while sparing healthy tissues in the prostate as well as the  
surrounding tissues including the urethral and rectal walls of a patient. The prostate gland  
encircles the urethra immediately below the bladder. The prostate, which is the most  
frequently diseased of all internal organs, is the site of a common affliction among older  
men, benign prostatic hyperplasia (BPH), acute prostatitis, as well as a more serious  
20 affliction, cancer. BPH is a nonmalignant, bilateral nodular tumorous expansion of prostate  
tissue occurring mainly in the transition zone of the prostate. Left untreated, BPH causes

obstruction of the urethra that usually results in increased urinary frequency, urgency, incontinence, nocturia and slow or interrupted urinary stream.

[004] Recent treatment of BPH includes transurethral microwave thermotherapy in which microwave energy is employed to elevate the temperature of tissue surrounding the prostatic urethra above about 45° C, thereby thermally damaging the tumorous prostate tissue. U.S. Patent Nos. 5,330,518 and 5,843,144 describe methods of ablating prostate tumorous tissue by transurethral thermotherapy, the subject matter of which is incorporated by reference. However, improvements still need to be made in this type of therapy to further maintain or enhance the patency of the urethra after the thermotherapy treatment. In particular, urine flow is not always improved despite ablation of the tumorous tissue causing constriction of the urethra because edema produced by the transurethral thermo-therapy treatment blocks the urethra passage resulting in patients treated by the above methods to be fitted with catheters for several days or weeks after the thermotherapy treatment.

[005] U.S. Patent Nos. 5,007,437, 5,496,271 and 6,123,083 disclose transurethral catheters with a cooling balloon in addition to the anchoring or Foley balloon and are incorporated by reference herein. However, these patents circulate fluid, which acts as a coolant for removing heat preferentially from the non-prostatic tissue adjacent thereto, through the cooling balloons. The '083 patent further discloses the use of a thermotherapy catheter system taught by U.S. Patent No. 5,413,588 that employs chilled water between about 12°-15°C as the coolant. Chilled water significantly cools the urethra adjacent the cooling balloon. Likewise, the '271 patent describes a coolant as the fluid to keep the urethral wall temperatures cool. This chilling of the urethra does not aid in maintaining an opening within the heated urethra after the cooling balloon is removed, and reduces the therapeutic effect in the tissue immediately adjacent the urethral wall.

[006] Another known alternative to thermal surgery, as described in U.S. Patent No. 5,499,994, is to insert a dilation balloon in the urethra and to expand the dilation balloon to compress the obstructed urethra. However, the expansion of the dilation balloon occurs over 24 hours and the patient still is not cured of the diseased prostate and can cause adverse effects (e.g., tearing of the urethral walls). U.S. Patent No. 6,102,929 describes a post-operative procedure where the prostate tissue is expanded after the surgical procedure to enlarge the urethra to enable a patient to void comfortably. This expansion requires insertion of another device and requires the device to remain in the patient for a day or more.

10 [007] In view of the fact that post-treatment catheters or other devices are still considered necessary by the medical community, further improvements are needed in thermotherapy to avoid the obstruction caused by edema and to maintain and enhance the opening of the urethra.

### 15 **Summary of the Invention**

[008] The present invention is directed to a device and a method for thermally treating tissue adjacent a bodily conduit, such as a urethra, while preventing obstructions of the bodily conduit due to edema. To achieve this object, the instant invention employs a catheter with an energy-emitting source and a compression balloon surrounding the energy-emitting source through which a warmed fluid flows to warm the bodily conduit walls adjacent the compression balloon.

[009] While the instant invention will be described with respect to a preferred embodiment where the bodily conduit is the urethra and prostatic tissue is to be treated by thermotherapy, the combination of warmed fluid, compression and microwaves can be used to achieve the above goal in other bodily conduits including, but not limited to,

cardiovascular, esophageal, nasal pharynx, and rectal cavities. That is, it is a goal of the instant invention to open up bodily conduits so that the normal function of that conduit is not hampered. The power to the energy-emitting source and diameters and shaping of the compression balloon and catheter will vary depending upon the tissue or bodily conduit to  
5 be treated.

[010] A minimally invasive RF, microwave, or ultrasound focused-energy producing system that compresses the targeted area is used in combination with heat-sensitive liposomes encapsulating pharmaceutical agents, for minimally invasive targeted treatment of large tumor masses, as well as the treatment of non-cancerous enlarged prostate. The  
10 focused energy heats the targeted area and activates the heat-sensitive liposomes and releases drugs in targeted tissue in accordance with the invention.

[011] Unlike known techniques that circulate a coolant to cool the urethral walls, the instant invention circulates a warmed fluid to maintain the temperature of the urethra above 30°C. Applicants recognized that a biological stent or molded opening was not able  
15 to be formed with cooled circulation fluid (i.e., fluid circulated into a patient in the range of 25°C - 30°C). A preferred range of temperature for the warmed fluid would be between 30° to 60° C. A preferred example would be to circulate fluid into a patient at 35°C. Applicants have formed a biological stent when the external temperature of the warmed fluid before circulation through a patient measures 33° C.

[012] According to the invention, a select volume of collagen-containing tissue surrounding the urethra is heated to a temperature greater than about 43° C for time sufficient to substantially destroy the select volume of tissue. Prior to energizing the energy-emitting source, the preshaped compression balloon is filled with the warmed fluid to expand the urethral walls compressing the prostate thereby reducing blood flow in the  
25 prostate surrounding the urethral walls so that the energy-absorptive heating is more

efficient in the region of constricted blood supply. As a result, the proteins of the urethral walls become denatured or are unraveled in the presence of the heat emitted from the energy-emitting source. The warmed fluid, which expands the compression balloon, supports the denaturing process while preventing the absorbed, energy-emitted heat from burning the urethral walls. This denaturing allows the urethral walls to conform to the expanded shape of the urethra created by the compression balloon and reduces the elasticity of the urethral walls so that a stent reinforcement period following the heating naturally solidifies the expanded shape resulting in a biological stent. That is, the expanded bodily conduit walls do not return to their previous shape after the compression balloon is deflated and removed thereby achieving a natural opening in the a bodily conduit, such as a urethra.

[013] According to a preferred embodiment of the invention, a stent reinforcement period of approximately 10 minutes or less follows the heating step. The stent reinforcement period maintains the pressure of the compression balloon after power to the energy-emitting source has been turned off so that a solidified expanded urethra is achieved minutes after thermotherapy and a catheter or other device is not necessary.

[014] The compression balloon is generally cylindrical with a sloped area on both sides of the compression balloon and is symmetrical along the length of the diameter according to a preferred embodiment. The position of the energy-emitting source in the preferred embodiment may be fixed. However, the compression balloon may be of any shape to create a desired mold or stent within a bodily conduit or urethra and may be asymmetrical along the length of the catheter.

[015] The compression balloon needs to maintain about 10-25 psi against the urethral wall along the length of the catheter with the preferred level of pressure being about 15 psi.

The compression balloon may have a variable diameter along the length of the catheter.

Alternatively, the compression balloon may be a single balloon or multiple balloons.

[016] In one embodiment, the diameter of the compression balloon varies across the radius to achieve an asymmetric molding of the bodily conduit. Alternative shapes of the  
5 compression balloon would include cone-shaped cylinders where the apex is adjacent the bladder neck or directed away from the bladder neck depending on the desired biological stent. These cone-shaped cylinders would enable the energy-emitted heat to focus on a particular area surrounding the bodily conduit, as well as create a biological stent or opening corresponding to this shape.

10 [017] According to the invention, a warmed fluid is preferably circulated through the compression balloon in conjunction with an outflow restriction so that the pressure of flow in the balloon is maintained at about 10-25 psi. The positioning of the inlet and outlet orifices in the compression balloon enables laminar flow within the compression balloon. Further, the inlet and outlet orifices in the compression balloon are arranged as to  
15 minimize air pockets in the balloon and thus, "hot spots" which occur as a result of the air pockets.

[018] In addition to the various shapes of the compression balloon, the compression balloon could be partially covered with a grounded or ungrounded conductive material that shields or absorbs the energy-emitting rays so that the heat could be reduced at some  
20 portions of the prostatic tissue and focused at other portions. In this embodiment, the energy-emitting source or microwave antenna may be movable so that the position of its energy-emitting portion can vary to optimize the heating of tissue for a particular therapy. The preferred location and movement, if any, of the energy-emitting source would depend on the size, shape and the shielding of the compression balloon.

[019] In another embodiment, the focused radiation together with the compression from the compression balloon may be used to activate heat-sensitive liposomes carrying a drug. Consequently, a thermodynamic therapy system including a thermally activated drug delivery system, which is provided within the bloodstream of a patient under therapy, efficiently transfers heat so that drug delivery within the prostate can be improved. The drug delivery system releases a selected drug at the treatment area in response to the treatment area being heated by the focused radiation. A higher concentration of released pharmaceutical agent carried in the heat-sensitive liposomes or other heat-sensitive drug carrier can result in a long-term efficacy of the treatment.

10 In accordance with an aspect of the present invention, there is provided the use of thermotherapy for treating tissue adjacent a bodily conduit, said thermotherapy comprises: an energy-emitting source containing a catheter for use in a bodily conduit, said energy-emitting source for use to provide focused energy to heat tissue to be treated adjacent the bodily conduit; a compression balloon disposed on said catheter for use to expand the  
15 bodily conduit walls and compress the tissue to be treated; an encapsulated drug within a heat-sensitive carrier used within the region of the tissue to be treated; and approximately 43° C heat for use to heat a portion of the tissue surrounding the bodily conduit for a time sufficient to destroy the heated portion of the tissue via the energy-emitting source where the heat activates the heat-sensitive carrier to  
20 activate the release of the encapsulated drug targeting the tissue to be heated.

In accordance with another aspect of the present invention, there is provided an apparatus of treating tissue adjacent to a bodily conduit using thermotherapy comprising: an energy-emitting source containing catheter adapted to be inserted into a bodily conduit so that an energy-emitting source is positioned adjacent a region of tissue to be treated  
25 so that focused energy from the energy-emitting source heats the tissue to be treated adjacent the bodily conduit; a compression balloon disposed on the catheter; means for providing a circulating fluid over 30° C for inflating the compression balloon to a pressure sufficient to expand walls of the bodily conduit and to compress the tissue to be treated; and means for injecting a drug encapsulated within a heat-sensitive carrier  
30 within the region of tissue to be treated; wherein the energy-emitting source heats a portion of the tissue surrounding the bodily conduit to a temperature of approximately 43°C for a time sufficient to destroy the heated portion of the tissue via the energy-emitting source where the heat activates the heat-sensitive carrier to activate the release of the encapsulated drug and the drug targets the tissue to be heated.

In accordance with one aspect of the present invention, there is provided the use of thermotherapy for treating tissue adjacent a bodily conduit, said thermotherapy comprises: a catheter defining a central lumen and containing an energy-emitting source within the central lumen the catheter for use in a bodily conduit, said energy-emitting source for use to provide focused energy to heat tissue to be treated adjacent the bodily conduit; a compression balloon disposed on said catheter for use to expand the bodily conduit walls and compress the tissue to be treated; a plurality of inlets disposed at a first location near a proximal end portion of the compression balloon for use in circulating a fluid into the compression balloon to inflate the compression balloon to a pressure sufficient to expand the bodily conduit walls; a plurality of outlets disposed at a second location near a distal portion of the compression balloon for use to circulate the fluid out of the compression balloon, the first location being disposed proximally of the second location, the plurality of outlets in fluid communication with the central lumen; an encapsulated drug within a heat-sensitive carrier for use within the region of the tissue to be treated; and approximately 43° C heat for use to heat a portion of the tissue surrounding the bodily conduit for a time sufficient to destroy the heated portion of the tissue via the energy-emitting source where the heat activates the heat-sensitive carrier to activate the release of the encapsulated drug targeting the tissue to be heated.

In accordance with one aspect of the present invention, there is provided an apparatus of treating tissue adjacent to a bodily conduit using thermotherapy comprising: a catheter defining a central lumen and containing an energy-emitting source within the central lumen, the catheter adapted to be inserted into a bodily conduit so that an energy-emitting source is positioned adjacent a region of tissue to be treated so that focused energy from the energy-emitting source heats the tissue to be treated adjacent the bodily conduit, the catheter defining a central lumen; a compression balloon disposed on the catheter; a plurality of inlets disposed at a first location near a proximal end portion of the compression balloon for circulating a fluid into the compression balloon to inflate the compression balloon to a pressure sufficient to expand the bodily conduit walls; means for providing a circulating fluid over 30° C for inflating the compression balloon to a pressure sufficient to expand

walls of the bodily conduit and to compress the tissue to be treated; and means for injecting a drug encapsulated within a heat-sensitive carrier within the region of tissue to be treated; wherein the energy-emitting source heats a portion of the tissue surrounding the bodily conduit to a temperature of approximately 43°C for a time sufficient to destroy the heated portion of the tissue via the energy-emitting source where the heat activates the heat-sensitive carrier to activate the release of the encapsulated drug and the drug targets the tissue to be heated.

### **Brief Description of the Drawings**

[020] These and other features and advantages of the invention will be further understood from the following detailed description of the preferred embodiment with reference to the accompanying drawings in which:

FIG. 1 is a vertical sectional view of a male pelvic region showing urinary organs affected by benign prostatic hyperplasia and an inserted catheter according to the invention with inflated compression and Foley balloons;

FIG. 2 is an enlarged portion of FIG. 1;

FIG. 3 is a plan view of the urethral catheter of the present invention;

FIG. 3a is a cross-sectional view of the urethral catheter of FIG. 3 taken along line a-a; FIG. 3b shows an alternative embodiment of the warmed fluid pumping system;

FIG. 4 illustrates the fluid flow through the catheter for inflation of the compression balloon;

FIGS. 5a and 5b are schematic, cross-sectional views of a urethra showing the

compression balloon in the uninflated and inflated states, respectively to illustrate the expansion of the urethral walls and prostate according to the invention;

FIG. 6 is a schematic cross-sectional view of the urethra illustrating an inflated, asymmetric compression balloon according to the invention; and

5 FIGS. 7a-d illustrate alternative compression balloon shapes and techniques for additional shielding implementations.

### **Detailed Description Of The Preferred Embodiments**

[021] The present invention is directed to a device and a method for thermally treating  
10 tissue adjacent a bodily conduit, such as a urethra, while preventing obstructions of the bodily conduit due to edema. In addition to focused energy and compression, drug delivery may aid in long term efficacy of treatment. The following will describe method, systems and alternatives of the method and apparatus according to the present invention.

[022] A first method and apparatus of maintaining or expanding the diameter of the  
15 urethra into a selected urethral shape after microwave thermotherapy treatment for benign prostatic hyperplasia to restore patency to the urethra is illustrated in Figures. 1-6. Figure 1 is a vertical sectional view of a male pelvic region showing the effect of benign prostatic hyperplasia (BPH) on the urinary organs. Urethra 10 is a duct leading from bladder 11, through prostate 12 and out orifice 13 of penis end 14. Benign tumorous tissue growth  
20 within prostate 12 around urethra 10 causes constriction of urethra 10, which interrupts the flow of urine from bladder 11 to orifice 13. The tumorous tissue of prostate 12, which encroaches urethra 10 and causes the constriction (not shown, as compression balloon 112 is inflated), can be effectively removed by heating and necrosing the encroaching  
tumorous tissue. Ideally, with the present invention, periurethral tumorous tissue of  
25 prostate 12 anterior and lateral to urethra 10 is heated and necrosed while avoiding

unnecessary and undesirous damage to urethra 10 and to adjacent healthy tissues, such as external sphincter 17, rectum 18, and bladder neck 19.

[23] Figure 2 is an enlarged sectional view of Figure 1 illustrating specific anatomical features including urethra 10 and bladder 11 and showing a catheter 100 according to the invention with an inflated compression balloon 112 and an inflated Foley or anchoring balloon 118. As shown on Figures 1-4, the instant invention employs a catheter 100 with an energy-emitting source 110 and a compression balloon 112 surrounding the energy-emitting portion of source 110 through which a warmed fluid flows to warm the urethra walls adjacent the compression balloon. A selective heating of benign tumorous tissue in prostate 12 (transurethral thermotherapy) is made possible by energy-emitting-containing catheter 100 of the present invention. A rectal probe 102 with a number of sensors is inserted into rectum 18 and measures the amount of heat generated by the absorbed emitted energy at the rectal wall.

[024] As shown in Figure 2, three sensors 104 are mounted on probe 102. The sensors are preferably integrally mounted at differing radial locations on the probe and spaced approximately 1 centimeter from one another. Foley balloon 118 is inserted into a patient's bladder so that the proximal end of the compression balloon is located at the patient's prostate immediately distal of the bladder neck. The length of compression balloon 112 varies depending upon the size of a patient's bladder. A typical length of the compression balloon would be about 40 millimeters and the length can range from 25 to 60 millimeters.

[025] Catheter 100 would be around 18 French (French is a measurement equal to .333 mm or .013 inch). Since the average diameter of a male adult human is about 22 French, the deflated compression balloon 112 that surrounds the catheter would add approximately 2 French so that diameter of catheter 100 and balloon 112 would be less than that of the patient's urethra for ease of insertion and less pain for the patient. Multi-Lumen Shaft 100

and associated molded parts are preferably extruded of a medical grade polymer sold by Concept Polymer Incorporated under the trademark C-Flex™. The compression balloon is preferably molded from a medical grade polyester material sold by Allied under the trademark PET™, that has a limit of stretch based on its initial maximum molded shape.

5 Alternative materials can include a silicone material manufactured by Dow Corning Inc. under the trade name Silastic R™ type Q7-4850 and type Q7-4765, for the shaft extrusion and the molded manifold, and Elastosil type LR3003/30Us for the anchoring balloon 118. The material of catheter 100 preferably has a Shore D hardness between 50D and 80D.

[026] After full insertion (i.e., the deflated Foley balloon reaching into the patient's  
10 bladder), a fluid (sterile water) is pumped through the Foley inflation valve 113 thereby to inflate Foley balloon 118 and hold the catheter within the patient's urethra. Inflation valve 113 maintains fluid in the Foley balloon with the desired pressure so that the catheter is anchored in the patient. However, the catheter is still capable of limited longitudinal movement with respect to the urethra. After Foley balloon 118 has been inflated, a warmed  
15 fluid, preferably a low-loss liquid (e.g., deionized or sterile water), is slowly pumped through the one or more catheter inflation/circulation lumens 120 (Figure 3a) into the prostate compression balloon 112 to inflate the same expanding the urethral walls and maintaining the temperature of the urethral walls above 30°C. The diameter of the inflated compression balloon would be approximately in the range of 25 - 60 French. The warmed  
20 fluid used to inflate compression balloon 112 is preferably a minimally energy absorptive solution which conducts microwaves to the tissue to be heated more efficiently.

[027] A typical implementation of a catheter according to the invention is shown in Figure 3. Foley balloon 118 is deflated in this Figure. As shown on the left-hand side of the Figure, a Foley inflation valve 113, a warmed, sterile-fluid intake 115a and a sterile-  
25 fluid outtake 115b are provided to receive fluid. The sterile-fluid intake and outtake 115a,

115b enable the circulation of sterile fluid in the compression balloon during  
thermotherapy and maintain the desired pressure to achieve the specific fluid flow pattern  
and distribution of fluid within the balloon. A central lumen 126 receives the energy-  
emitting source 110, which may be an antenna in the form of a coaxial cable. As shown in  
5 Figure 3a, protrusions 127 are formed in central channel 126 in order to keep energy-  
emitting source 110 centralized inside catheter 100 and to create channels for the outtake  
fluid flow. Protrusions 127 enable the distance between the energy-emitting source and  
outside wall of the catheter to remain constant thereby ensuring a consistent heating  
pattern at the energy-emitting portion of the source 110. The energy emitting source 110  
10 is directed coupled to the low-loss fluid to maximize emitted power and to cool the shaft of  
the energy-emitted source.

[028] As shown in Figure 4, orifices 122, 124 are employed in one or more of catheter  
lumens 120 on both sides of compression balloon 112 so that warmed fluid can be pumped  
through lumens 120 into compression balloon 112 at one end and out at the other end. The  
15 warmed water is then circulated through central orifice 126, which holds an energy-  
emitting source 110, such as a microwave antenna, and flows out of catheter 100 external  
of a patient. The placement and diameter of the orifices 122, 124 enables sufficient fluid  
flow and pressure of about 10-25 psi to be maintained in compression balloon 112 during  
the entire thermotherapy treatment. In the preferred embodiment, outtake-fluid-side  
20 channel is fitted with a restrictive orifice 116 to limit the compression balloon pressure for  
maximum fluid flow through compression balloon 112. The restrictive orifice 116, in an  
alternative embodiment, can be located immediately external to the catheter in the  
connective tubing (e.g., 115a, 115b) used to connect the catheter to the external fluid  
warming pumping system (Figure 3b). The pressurized circulation of the warmed fluid is  
25 such that air pockets are reduced in the inflated balloon. Accordingly, air pockets in the

compression balloon, which may result in "hot spots" causing burns on the urethral walls, are avoided. This results in the desired compression of the prostatic urethral tissue, without burning the urethral walls, which is maintained during and after the thermotherapy treatment.

5 [029] It is desired to heat the diseased prostate tissue to a therapeutic temperature (greater than about 43°C) while maintaining the temperature of the non-prostate tissue lining the urethra above 30°C. The non-prostate tissue includes the urethral wall and adjacent tissue and is disposed between the energy-emitting source 110 and prostatic tissue 12. The energy-emitting portion 110a of source 110 is disposed in catheter 100 so that it rests  
10 within the compression balloon 112. Energy-emitting portion 110a preferably emits an irradiating microwave field, which varies as an inverse function (e.g., inverse square) of the distance between the energy-emitting portion 110a (e.g., microwave antenna) and the tissue to be heated. Consequently, the non-prostate tissue of urethral wall 10, which is closer to energy-emitting portion 110a than prostatic tissue 12, would be heated to a higher  
15 temperature than the prostatic tissue to be treated. Likewise, proximate prostate tissue would be heated to a higher temperature than more distal prostate tissue.

[030] U.S. Patent No. 5,007,437 to Sterzer discloses the use of a balloon to compress the prostate tissue and to move the urethral wall away from the microwave antenna, which produces the heat. This method reduced the microwave field intensity and the resultant  
20 heat produced at the urethral wall by moving the urethral wall further from the heat-producing antenna. However, Sterzer also employed a circulating fluid to continuously cool the urethral wall while the urethral wall was inflated. Applicants recognized that this circulating coolant was preventing the urethral wall and adjacent prostatic tissue from reaching a temperature sufficient to denature the protein or enable plastic remodeling. As  
25 a result, Applicants theorized that the use of an inflated prostate compression balloon

together with the circulation of warmed fluid would mitigate the denaturing problem, as shown in Figures 5a and 5b.

[031] Figures 5a and 5b respectively show a cross-section of a deflated compression balloon and a cross-section of an inflated compression balloon. The radial distances from energy-emitting source or microwave antenna 110 to distal prostatic tissue 202 and proximal tissue 204, which includes the urethral wall and adjacent non-prostatic tissue, when compression balloon 112 is deflated are smaller than those distances are when compression balloon 112 is inflated. As shown, inflated compression balloon 112 forms a symmetrical toroid extending around the entire circumference of the urethral catheter. Specifically, the radial distance  $R_{1b}$  from microwave antenna 110 to the inner circumference of proximal tissue 204 with inflated compression balloon 112 is significantly larger than the corresponding radial distance  $R_{1a}$  with deflated compression balloon 112. Similarly, the radius  $R_{2b}$  to the inner circumference of prostate tissue 202 with inflated compression balloon 112 is significantly larger than the corresponding radial distance  $R_{2a}$  with deflated compression balloon 112. Because prostate tissue is soft and compressible, the difference between the outer and inner radii  $R_{3b}$  and  $R_{2b}$  of prostate tissue 202 with inflated compression balloon 112 is substantially reduced with respect to the corresponding difference between radii  $R_{3a}$  and  $R_{2a}$  with deflated compression balloon 112.

[032] Consequently, the inflated compression balloon causes the prostate 12 to be compressed from the urethral wall thereby decreasing the thickness of the tissue between the compressed wall of the urethra and the margins of the prostate capsule. The tissue more distal 202 is not as compressed as the tissue more proximal to the urethra 204. Since the actual tissue thickness through which the energy emitted by the antenna 110 is less, the energy deposited is more evenly distributed throughout the entire prostate capsule. This

makes it possible to heat the prostatic tissue more evenly and to higher therapeutic temperatures without heating any part of the non-prostatic tissue beyond its maximum safe temperature.

[033] At the same time the inflated compression balloon 112 constricts the blood flow in the compressed prostate so that the irradiated heat is not carried away by the natural blood flow and thus makes this tissue more susceptible to heating by the emitted energy. Since the overall tissue thickness is reduced the amount of energy required to effectively heat the prostate tissue 204 to a therapeutic temperature is reduced. Conversely, in typical non-compressed therapies, the amount of energy required to raise the temperature of the more distal prostatic tissue 202, that may be adjacent to the rectal wall to a maximize safe temperature of 41°C will be significantly higher than required according to the invention. Thus, it is possible to heat the prostatic tissue more evenly and to higher temperatures without heating any part of the non-prostatic tissue beyond its safe maximum temperature.

[034] In order to heat proximal tissue 204 above a predetermined collagen transition temperature during a microwave thermotherapy treatment, warmed fluid above 30°C, preferably in the range of about 31°C - 60°C, is circulated through compression balloon 112, in contrast to a coolant. As a result, the urethral wall and adjacent tissue is sufficiently denatured so that a natural biological stent can be formed after the thermotherapy treatment.

[035] The warming of the urethral wall above 30°C and maintaining of this temperature serves to denature the proteins of the urethral wall; but does not heat the urethral wall beyond a maximum safe temperature. This denaturing allows the urethral walls to conform to the expanded shape of the urethra created by compression balloon 112 and reduces the elasticity of the urethral walls so that a stent reinforcement period following the heating of

the thermotherapy treatment naturally solidifies the expanded shape resulting in a biological stent. That is, the expanded urethral walls do not return to their previous shape after the compression balloon is deflated and removed thereby achieving a natural opening in the a bodily conduit, such as a urethra.

5 [036] The stent reinforcement period that follows the termination of the heating of the prostatic tissue requires that the compression balloon remain inflated at the desired pressure of 10-25 psi for less than about 10 minutes. During this reinforcement period, fluid typically no longer needs to be circulated through the compression balloon as only the maintaining of the pressure in the compression balloon serves to solidify the biological  
10 stent. That is, The stent reinforcement period maintains the pressure of the compression balloon after power to the energy-emitting source has been turned off so that a solidified expanded urethra is achieved minutes after thermotherapy and a urine drainage catheter or other device is not necessary.

[037] Compression balloon 112 is generally cylindrical with a sloped area on both sides  
15 of the compression balloon and is symmetrical along the length of the diameter according to a preferred embodiment. However, compression balloon 112 may be of any shape to create a desired mold or stent within a bodily conduit or urethra. As shown in Figure 6, the compression balloon 112' on catheter 100 is designed so that it inflates asymmetrically around catheter 100. The asymmetrical balloon 112' inflates a bodily conduit so that a  
20 region of tissue adjacent the bodily conduit receives more or less radiate energy from the energy- emitting source 110 depending upon the width of the inflated compression balloon 112'. The wider the inflated compression balloon, the more compressed the tissue adjacent the bodily conduit and the further from the heat producing source.

[038] Compression balloon 112 needs to maintain about 10-25 psi against the urethral  
25 wall along the length of the catheter with the preferred level of pressure being about 15 psi.

The compression balloon may have a variable diameter along the length of the catheter, as shown in Figs 7a-7d. Alternatively, the compression balloon may be a single balloon or multiple balloons.

[039] In one embodiment, the diameter of the compression balloon varies across the  
5 radius to achieve an asymmetric molding of the bodily conduit. This shape is shown in Figure 7a where the compression balloon only expands to about 27 French in the middle and 46 F on either end. Alternative shapes of the compression balloon would include cone-shaped cylinders (Figs. 7b-c) where the apex is adjacent the bladder neck or directed  
10 away from the bladder neck depending on the desired biological stent. These cone-shaped cylinders would enable the energy-emitted to be selectively focused on a particular area surrounding the bodily conduit, as well as create a biological stent or opening corresponding to this shape. Alternatively, the cone-shaped or other desired shaped  
balloons may provide preferentially localized therapy for a non-specific disease.

[040] In addition to the various shapes of the compression balloon, the compression  
15 balloon could be covered with a material that shields the energy-emitting rays so that the heat could be reduced at some portions of the prostatic tissue and focused at other portions. That is, the shielding would enable preferential heating of prostatic tissue. In this embodiment, the effective heating area of the catheter/balloon/antenna combination is controlled by a selective addition of distally located shielding material provided along the  
20 shaft of the catheter either internally or externally applied. Alternatively or in addition to the catheter shielding material, shielding material may be applied on a surface of the compression balloon, either internally or externally.

[041] The applied shielding when grounded selectively absorbs microwave energy  
emitted from the energy-emitting source or antenna to modify the heating pattern and to  
25 control the deposition of heat into the surrounding target tissue. To electrical ground the

shield, internally connected lead wires are passed through the fluid circulation lumens or embedded in the catheter shaft material and are connected to the most distal end of the catheter. These wires are then terminated to the external electrical surface of the energy-emitting source and/or terminated separately to a system grounding point for the adequate  
5 dissipation of the absorbed emitted energy. The amount and location of shielding provided on either the catheter shaft and/or the compression balloon is variable depending upon the desired heating pattern.

[042] In this embodiment, the energy-emitting source 110 or microwave antenna may be movable so that the position of its energy-emitting portion 110a can vary to optimize the  
10 heating of tissue for a particular therapy. As shown in Figure 3b, a longitudinal antenna locator device 128 would be able to move the antenna and lock the same into the desired position. The preferred location and movement, if any, of the energy-emitting source would depend on the size, shape and the shielding of the compression balloon.

[043] Accordingly, the method and apparatus of the present invention ablate the diseased  
15 tissue causing an obstruction in the bodily conduit, while forming a natural or biological stent in the bodily conduit so edema or swelling does not close the bodily conduit. As a result, an unobstructed opening in a bodily conduit, such as the urethra, is formed after the stent reinforcement period.

[044] Moreover, the circulation of warmed fluid, expansion and heating according to the  
20 invention effectively plastically remodels the collagen rich surrounding tissue into a selected shape having a desired expanded diameter. Thus, the instant invention can increase the patency of the prostatic urethra and surrounding tissue by increasing a urethral diameter.

[045] More efficient drug delivery may be achieved when used in combination with the  
25 above-described focused energy and compression thermotherapy treatment. Liposomes are

microscopic man-made lipid particles (organic compounds including the fats, fat-like compounds and the steroids) that can be engineered to entrap drugs, creating new pharmaceuticals with enhanced efficacy, better safety or both. In particular, the instant invention employs heat-sensitive liposomes. Thus, the toxicity of effective drugs can be targeted to cancerous tumors or the enlarged prostate due prostatitis through the use of liposome technology. Particular lipids are chosen to make liposomes with liquid-crystal phase transitions in the range of about 40° to 45° C where the liposomes undergo abrupt changes in physical properties. Liposomes can have one or more aqueous compartments that contain the pharmaceutical agent. These aqueous compartments are enclosed by a lipid bilayer. While the preferred temperature for activation of the drug carrier or liposome is approximately 41°C, lower temperature activation can be realized.

[046] A specific formulation for a heat-sensitive or thermosensitive liposome is described in U.S. Pat. No. 5,094,854 . Through the use of a higher concentration of liposomes, than in the prior art, the instant invention should increase the amount of generic or pharmaceutical drug released in the prostate. This increased drug per unit area is a result of the higher concentration and the focused energy employed with the compression of the target area.

[047] Although the present invention has been described with reference to preferred embodiments, workers skilled in the art will recognize that changes may be made in form and detail without departing from the spirit and scope of the invention.

We claim:

1. The use of thermotherapy for treating tissue adjacent a bodily conduit, said thermotherapy comprises:

a catheter defining a central lumen and containing an energy-emitting source within the central lumen the catheter for use in a bodily conduit, said energy-emitting source for use to provide focused energy to heat tissue to be treated adjacent the bodily conduit;

a compression balloon disposed on said catheter for use to expand the bodily conduit walls and compress the tissue to be treated;

a plurality of inlets disposed at a first location near a proximal end portion of the compression balloon for use in circulating a fluid into the compression balloon to inflate the compression balloon to a pressure sufficient to expand the bodily conduit walls;

a plurality of outlets disposed at a second location near a distal portion of the compression balloon for use to circulate the fluid out of the compression balloon, the first location being disposed proximally of the second location, the plurality of outlets in fluid communication with the central lumen; an encapsulated drug within a heat-sensitive carrier for use within the region of the tissue to be treated; and

approximately 43° C heat for use to heat a portion of the tissue surrounding the bodily conduit for a time sufficient to destroy the heated portion of the tissue via the energy-emitting source where the heat activates the heat-sensitive carrier to activate the release of the encapsulated drug targeting the tissue to be heated.

2. The use of claim 1, wherein the compression balloon surrounds the catheter and the energy-emitting source in the region of the tissue to be treated, and the compression balloon is to be inflated to a pressure sufficient to expand the bodily conduit walls and to compress the tissue to be treated with a warmed fluid; and the pressure in the compression balloon is to be maintained after heating is terminated for a time period sufficient to reinforce the expanded position of the bodily conduit walls such that the expanded bodily conduit walls remain open after the removal of the energy-emitting containing catheter.

3. The use of claim 2, wherein the warmed fluid for inflating the compression balloon maintains the therapeutic level of warmth of the bodily conduit while avoiding

burning of the bodily conduit walls.

4. The use of claim 1, wherein said encapsulated drug is for use before the introduction of said heat.

5. The use of claim 4, wherein said encapsulated drug is at the targeted tissue when said heat is to be introduced to heat the portion of the tissue surrounding the bodily conduit.

6. An apparatus of treating tissue adjacent to a bodily conduit using thermotherapy comprising:

a catheter defining a central lumen and containing an energy-emitting source within the central lumen, the catheter adapted to be inserted into a bodily conduit so that an energy-emitting source is positioned adjacent a region of tissue to be treated so that focused energy from the energy-emitting source heats the tissue to be treated adjacent the bodily conduit, the catheter defining a central lumen;

a compression balloon disposed on the catheter;

a plurality of inlets disposed at a first location near a proximal end portion of the compression balloon for circulating a fluid into the compression balloon to inflate the compression balloon to a pressure sufficient to expand the bodily conduit walls;

means for providing a circulating fluid over 30° C for inflating the compression balloon to a pressure sufficient to expand walls of the bodily conduit and to compress the tissue to be treated; and

means for injecting a drug encapsulated within a heat-sensitive carrier within the region of tissue to be treated; wherein the energy-emitting source heats a portion of the tissue surrounding the bodily conduit to a temperature of approximately 43°C for a time sufficient to destroy the heated portion of the tissue via the energy-emitting source where the heat activates the heat-sensitive carrier to activate the release of the encapsulated drug and the drug targets the tissue to be heated.

7. The apparatus of claim 6, wherein the tissue to be treated is the prostate and the drug encapsulated within a heat-sensitive carrier treats prostatitis.

8. The apparatus of claim 6, wherein the carrier is a heat-sensitive liposome.

9. The apparatus of claim 6, wherein the inflated compression balloon maintains pressure of about 10-25 psi during at least a portion of the thermotherapy.
10. The apparatus of claim 6, wherein the compression balloon surrounds the catheter and the energy-emitting source.
11. The apparatus of claim 6, wherein the energy-emitting source is a microwave antenna.
12. The use of claim 1, wherein the tissue is the prostate.
13. The use of claim 1, wherein the encapsulated drug treats prostatitis.

1/5

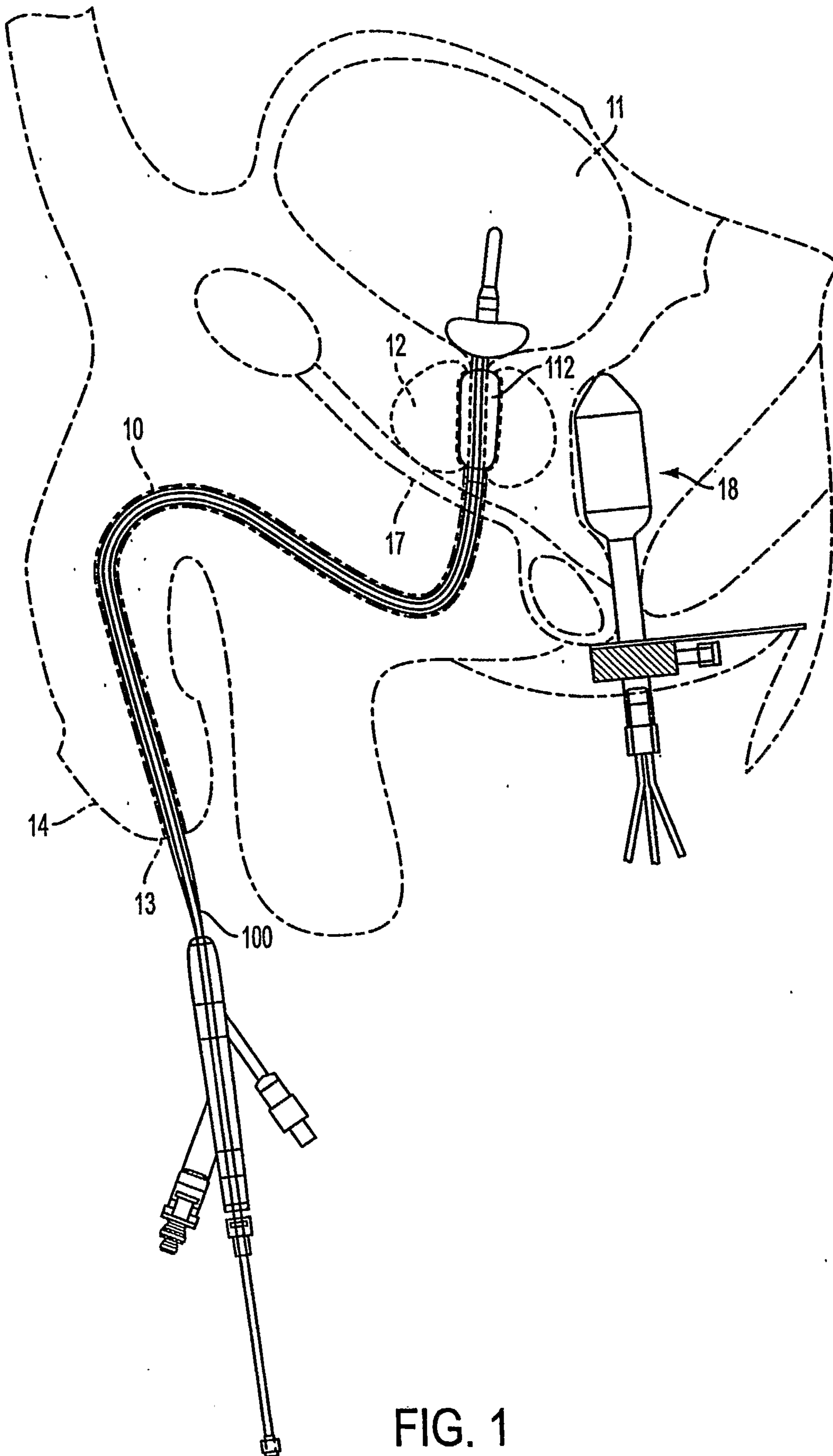

FIG. 1

2/5

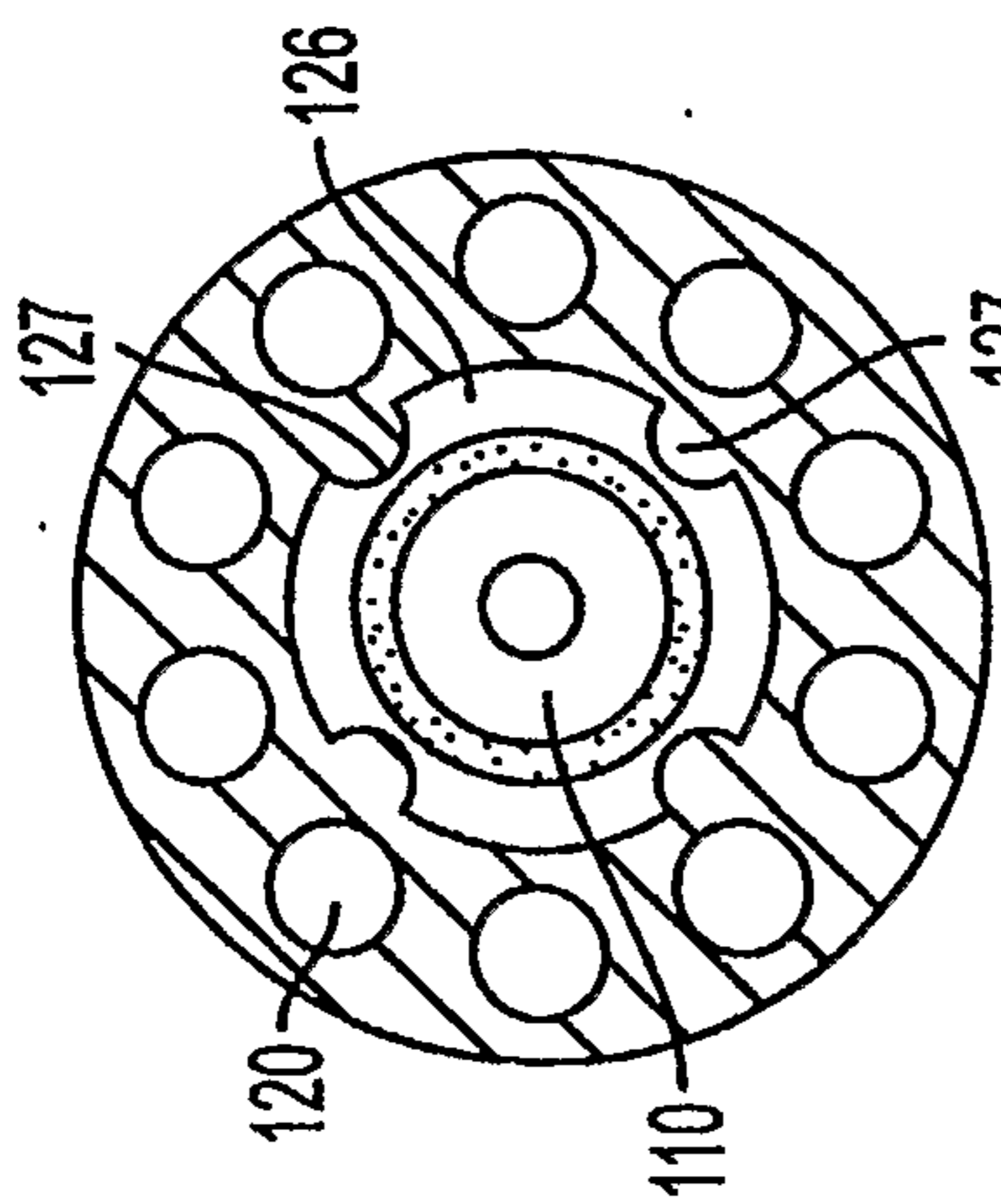
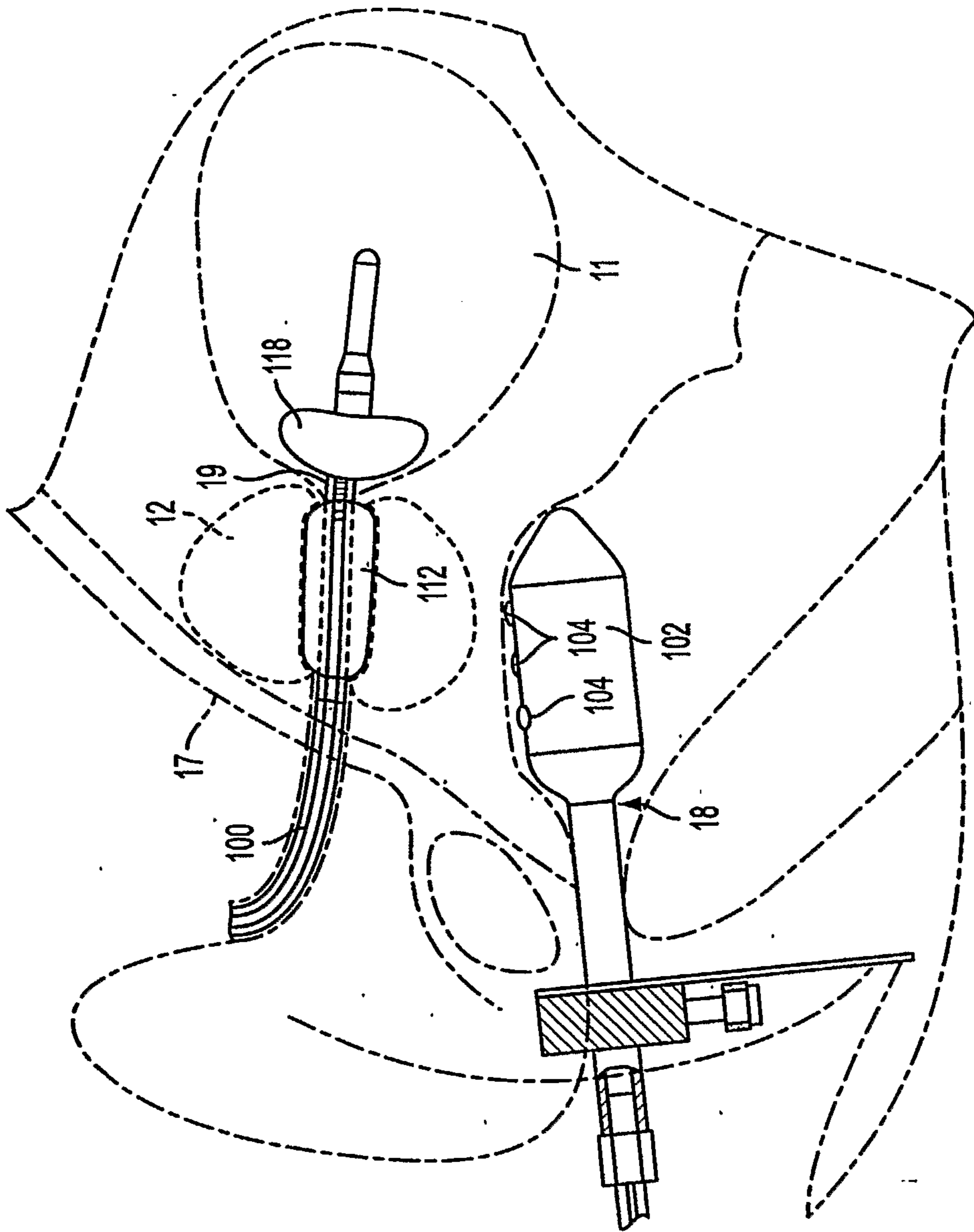

FIG. 3a

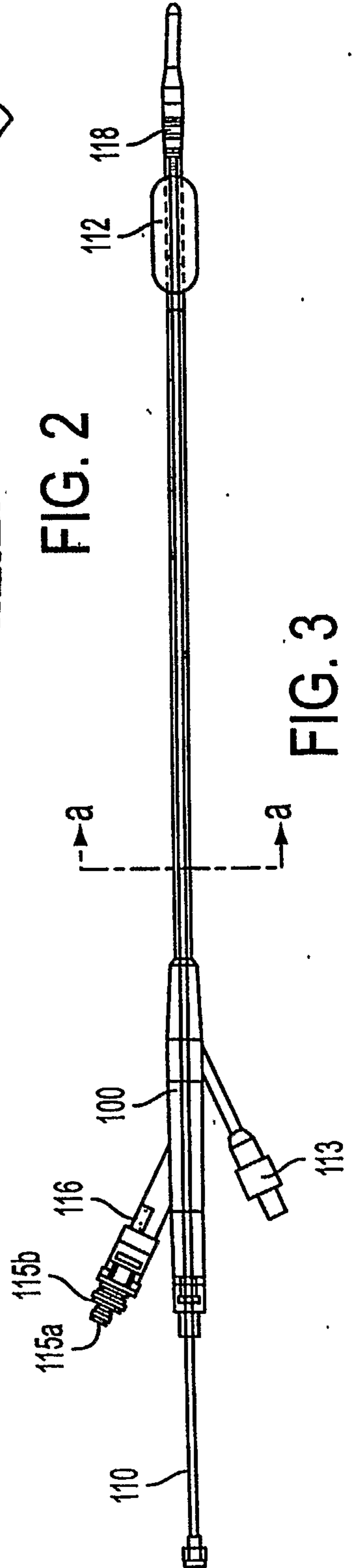

FIG. 2

FIG. 3

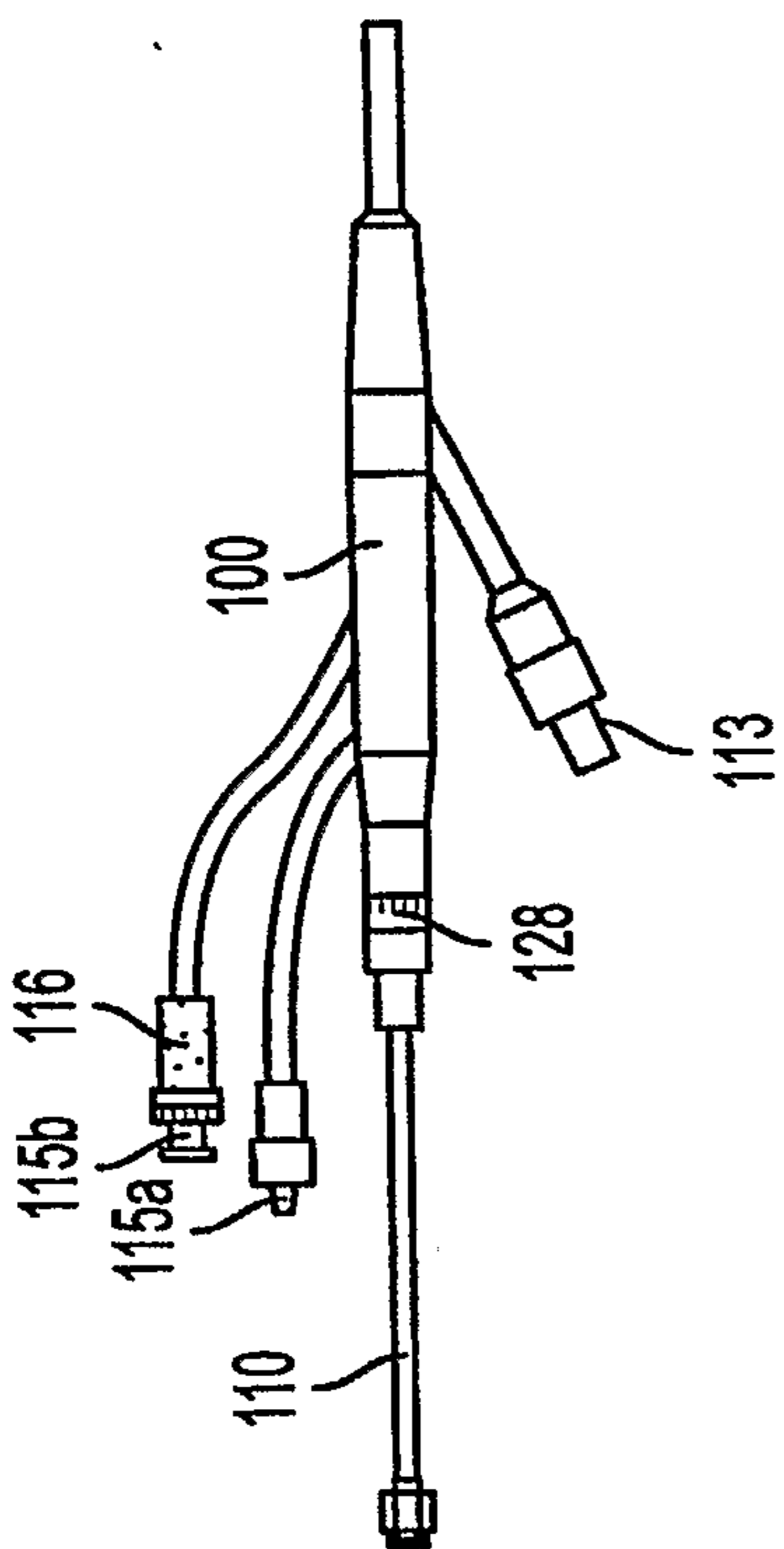

FIG. 3b

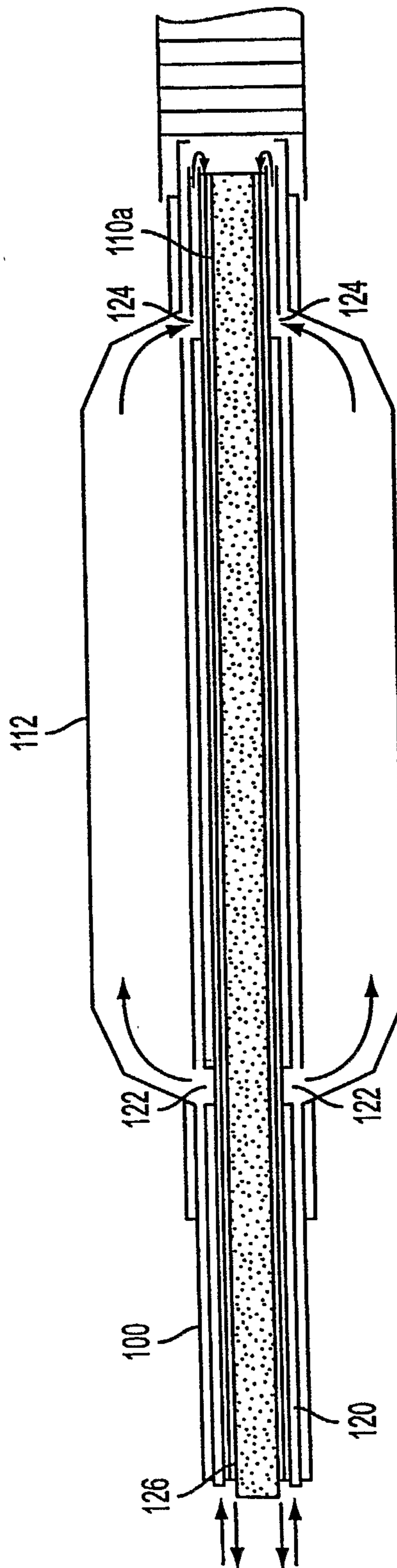

FIG. 4

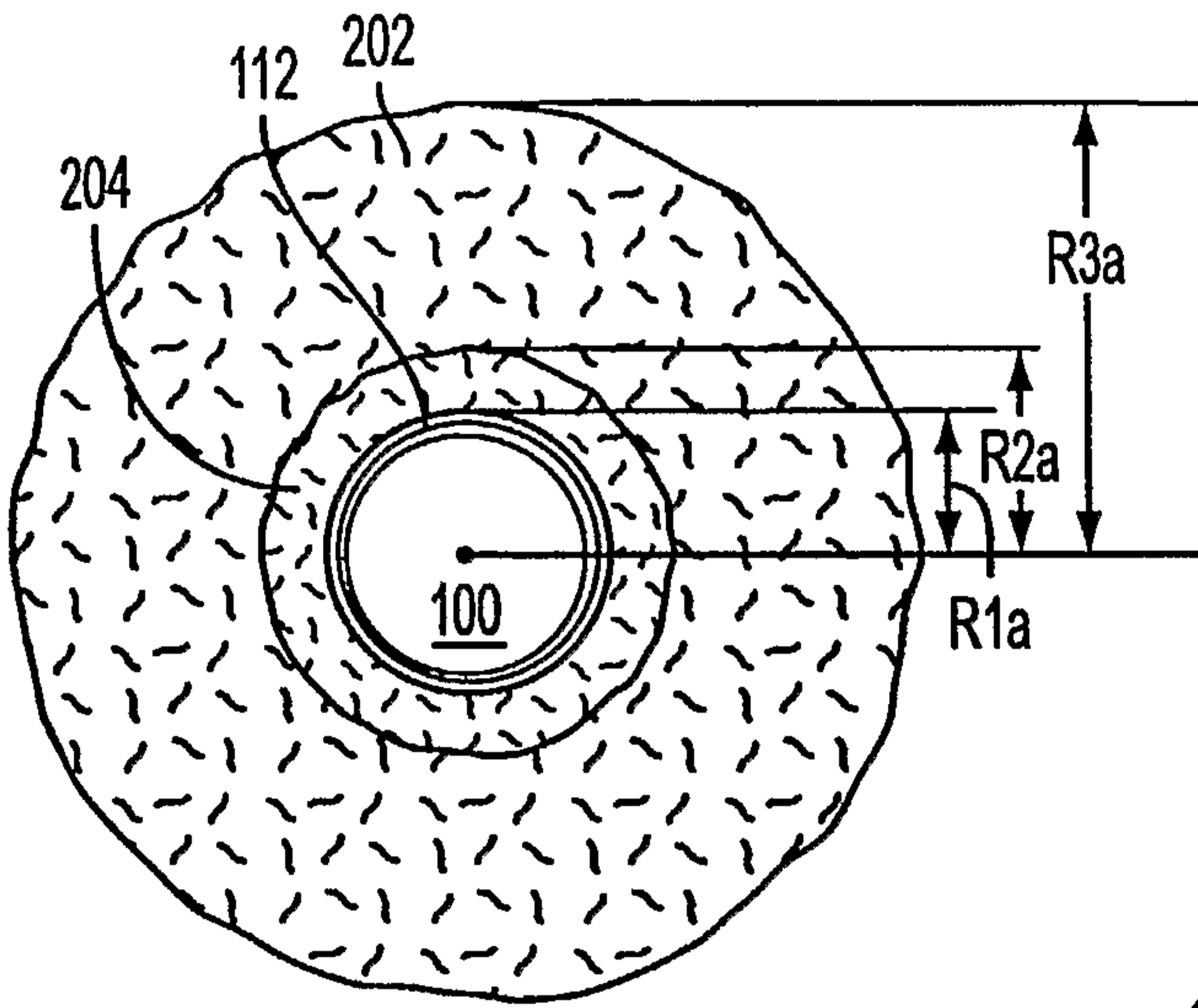

FIG. 5a

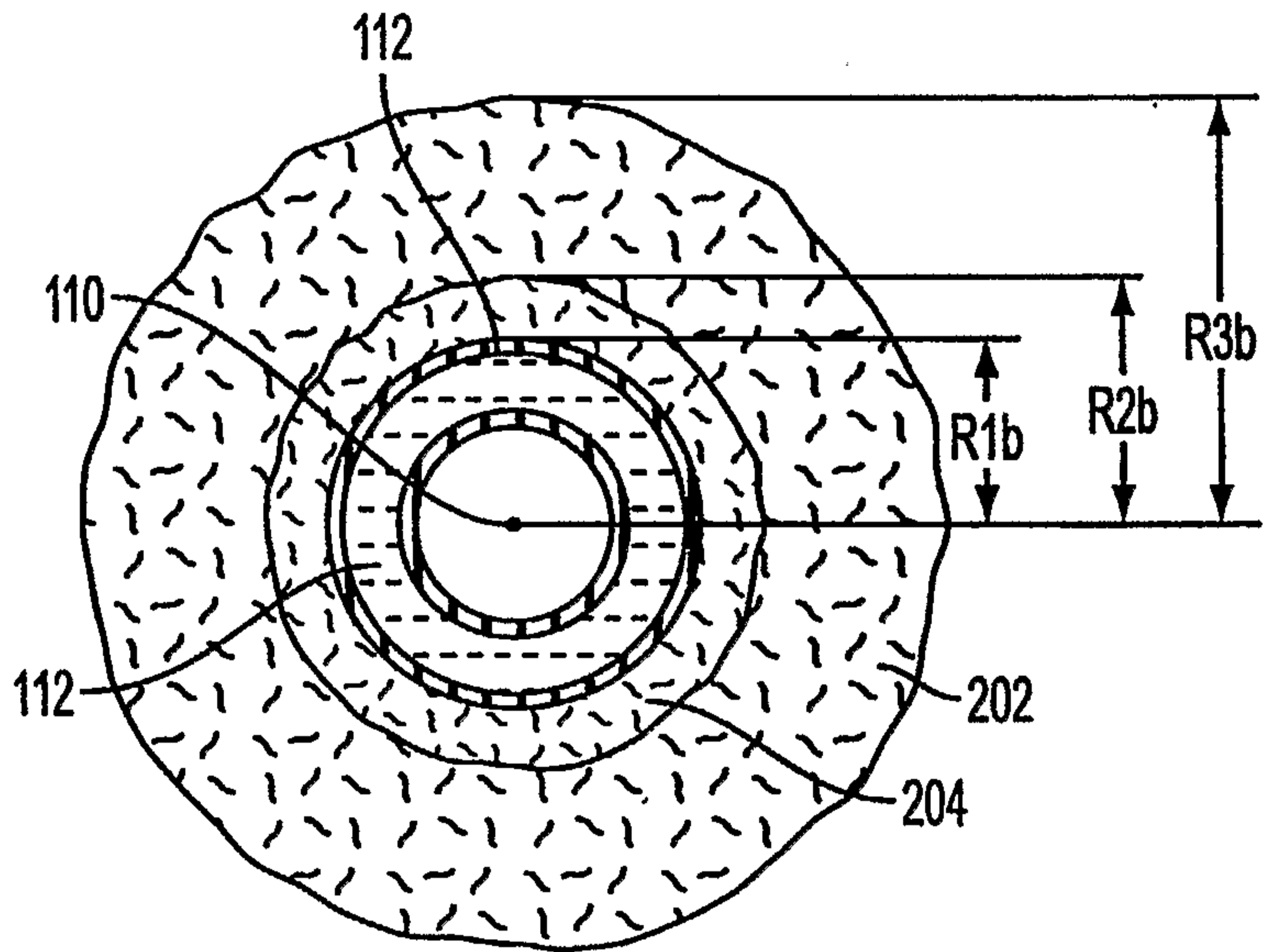

FIG. 5b

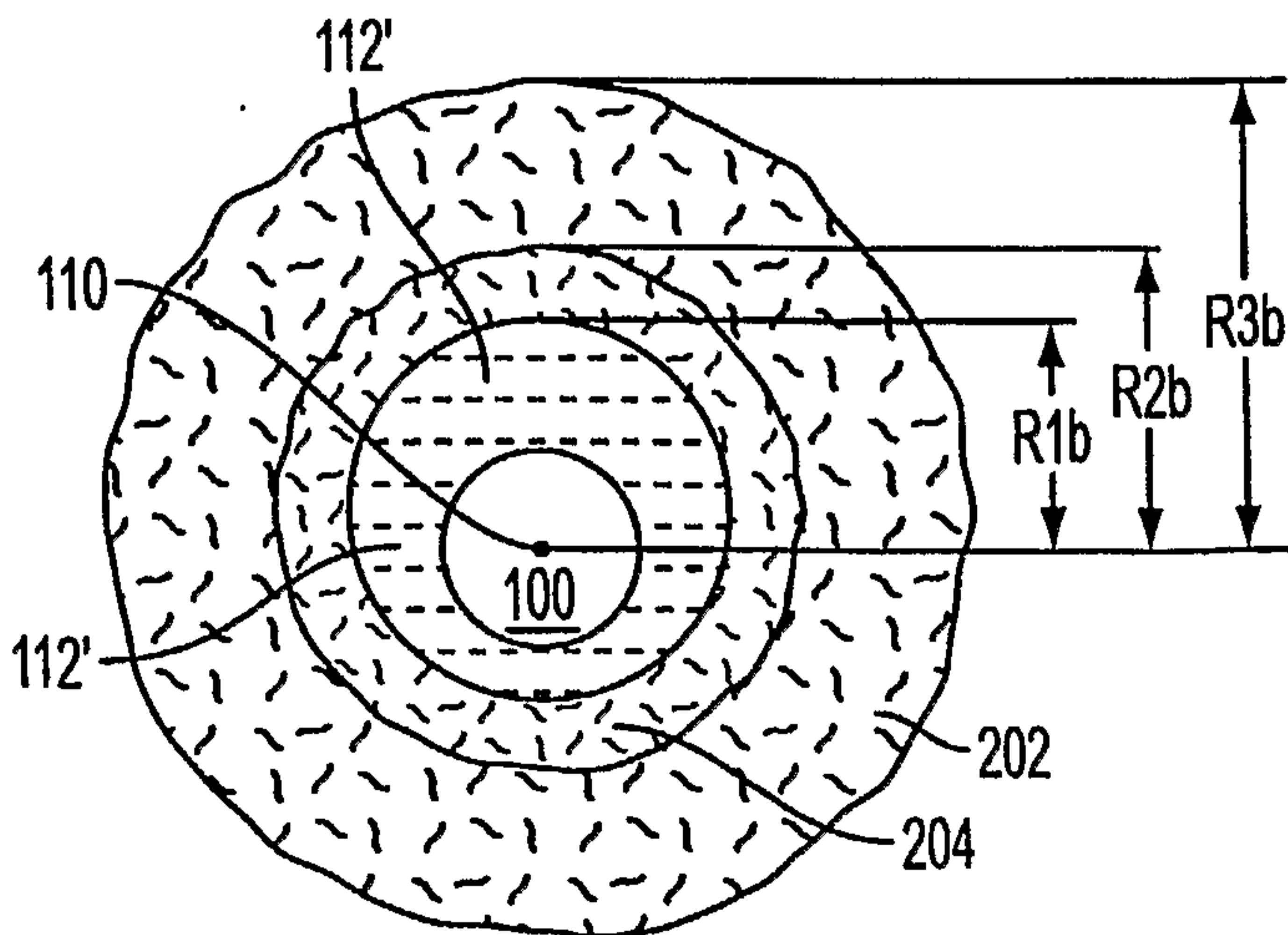

FIG. 6

5/5

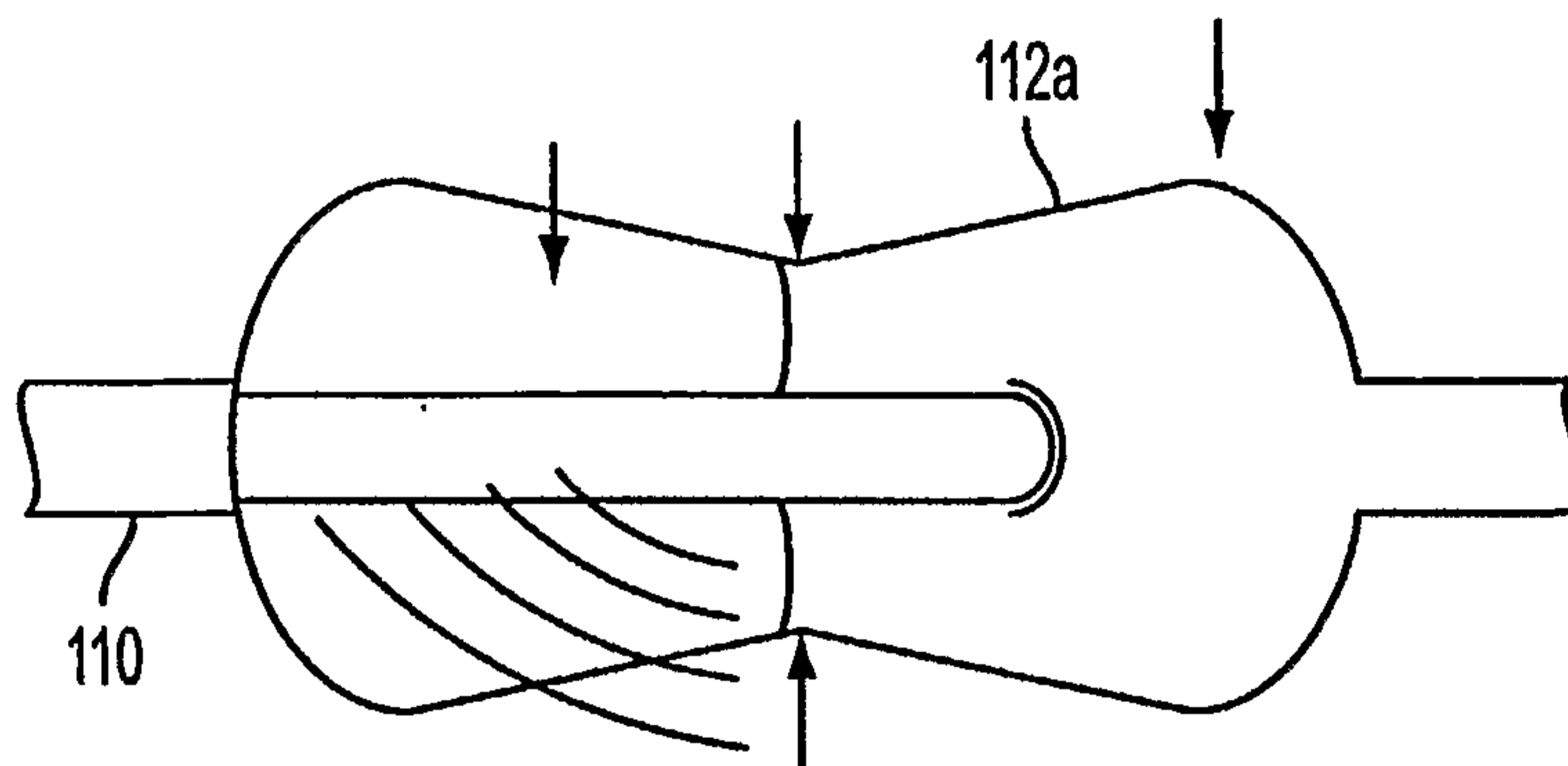

FIG. 7a

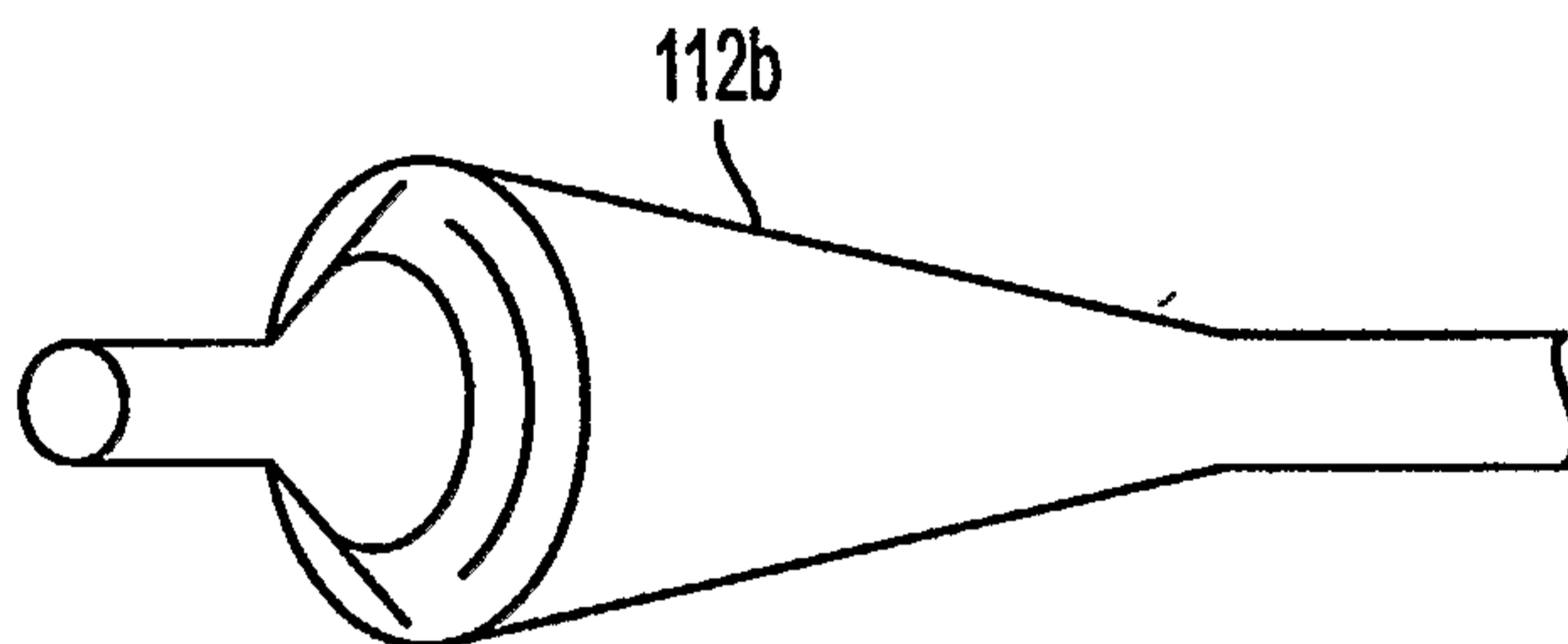

FIG. 7b

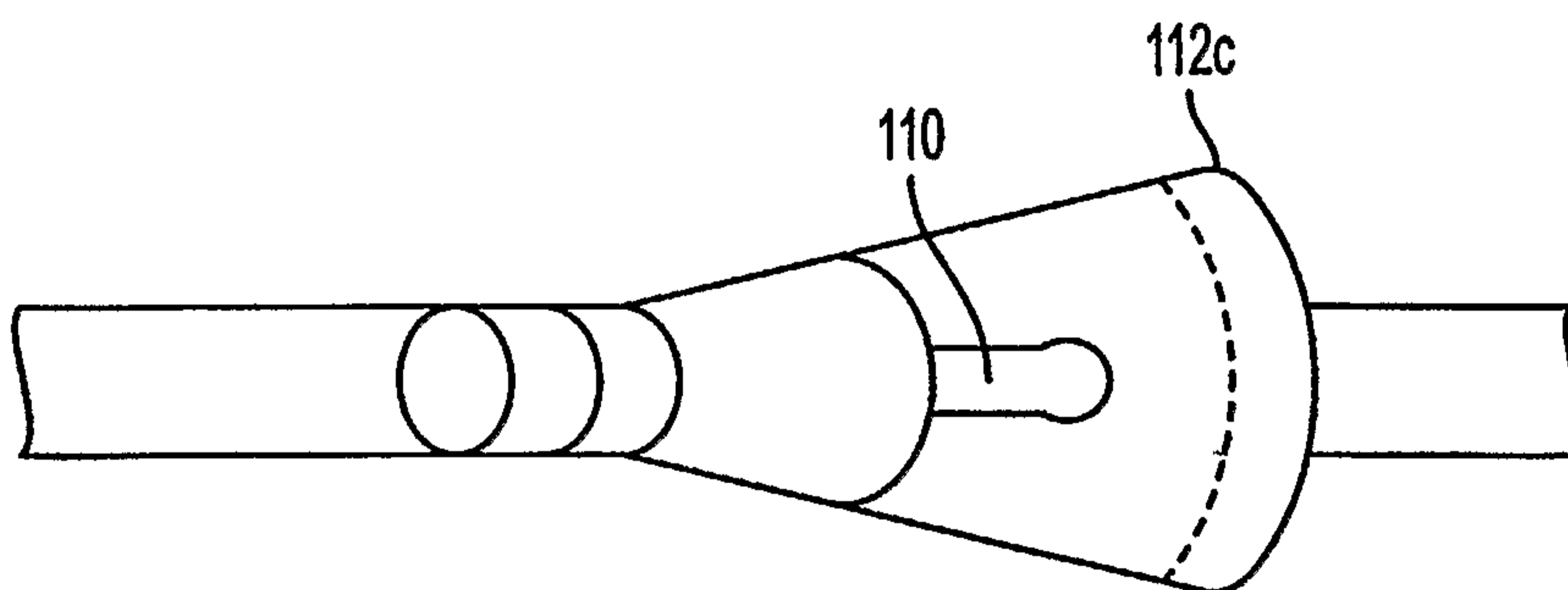

FIG. 7c

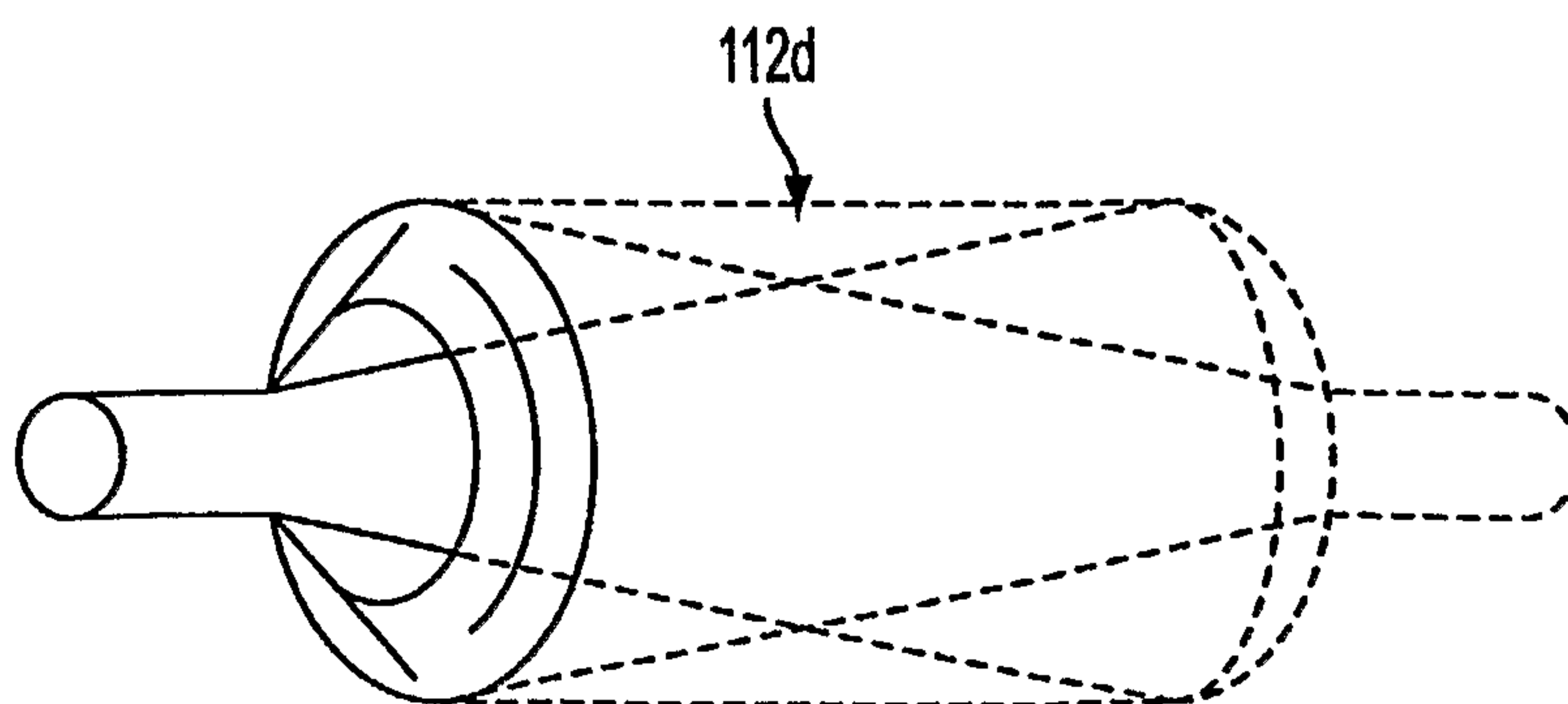

FIG. 7d

