



US00D855394S

(12) **United States Design Patent** (10) **Patent No.:** **US D855,394 S**
Funnell, II et al. (45) **Date of Patent:** **** *Aug. 6, 2019**

(54) **OVEN HANDLE**

(56) **References Cited**

(71) Applicant: **BSH Home Appliances Corporation**, Irvine, CA (US)

U.S. PATENT DOCUMENTS

(72) Inventors: **Richard W. Funnell, II**, Huntington Beach, CA (US); **Andrew Roberson**, Long Beach, CA (US); **Graham Sadtler**, Huntington Beach, CA (US)

| | | | | | | |
|----------|---|---|---------|-------------|-------|----------|
| D530,561 | S | * | 10/2006 | Kim | | D7/351 |
| D550,502 | S | * | 9/2007 | Jeon | | D7/350.1 |
| D568,100 | S | * | 5/2008 | Jeon | | D7/402 |
| D570,646 | S | * | 6/2008 | Jeon | | D7/402 |
| D572,110 | S | * | 7/2008 | Busalt | | D8/316 |
| D580,698 | S | * | 11/2008 | Kim | | D7/348 |
| D612,677 | S | * | 3/2010 | Jeon | | D15/89 |
| D633,329 | S | * | 3/2011 | Baek | | D7/351 |
| D670,527 | S | * | 11/2012 | Kim | | D7/340 |
| D710,646 | S | * | 8/2014 | Borjesson | | D7/349 |
| D724,889 | S | * | 3/2015 | Borjesson | | D7/349 |
| D736,055 | S | * | 8/2015 | Funnell, II | | D8/315 |
| D741,104 | S | * | 10/2015 | Funnell, II | | D7/348 |
| D745,310 | S | * | 12/2015 | Funnell, II | | D7/349 |

(73) Assignee: **BSH Home Appliances Corporation**, Irvine, CA (US)

(*) Notice: This patent is subject to a terminal disclaimer.

(**) Term: **15 Years**

(Continued)

(21) Appl. No.: **29/594,551**

Primary Examiner — Sheryl Lane

Assistant Examiner — Nicole C Shiflet

(22) Filed: **Feb. 21, 2017**

(74) *Attorney, Agent, or Firm* — Michael E. Tschupp; Andre Pallapies; Brandon G. Braun

Related U.S. Application Data

(62) Division of application No. 29/544,360, filed on Nov. 3, 2015, now Pat. No. Des. 784,751, which is a division of application No. 29/456,409, filed on May 31, 2013, now Pat. No. Des. 747,912.

(57) **CLAIM**

The ornamental design for an oven handle, as shown and described.

(51) **LOC (12) Cl.** **07-02**

(52) **U.S. Cl.** **D7/402**

(58) **Field of Classification Search**

USPC D7/387, 402-409, 393, 394, 323, 331, D7/332-337, 339, 340, 346-349, 351, D7/354, 358; D12/500, 501, 502, 204; D8/319, 316, 315; D15/89
CPC F24C 15/36; F24C 15/107; F24C 15/024; F24C 3/08; F24C 3/124; F24C 7/08; F24C 7/081; F24C 7/082; F24C 7/087; A47J 37/042; A47J 37/07; A47J 37/12; A47J 37/129; A47J 37/1295

DESCRIPTION

FIG. 1 is a front perspective view of an oven handle showing our new ornamental design; FIG. 2 is a front perspective view thereof, on an enlarged scale and without surrounding environment; FIG. 3 is a front view thereof; FIG. 4 is a rear view thereof; FIG. 5 is a right side view thereof, with the left side view thereof being a mirror image thereof; and, FIG. 6 is a top view thereof, with the bottom view being a mirror image thereof.

The broken lines represent environment and form no part of the claimed design.

See application file for complete search history.

1 Claim, 2 Drawing Sheets

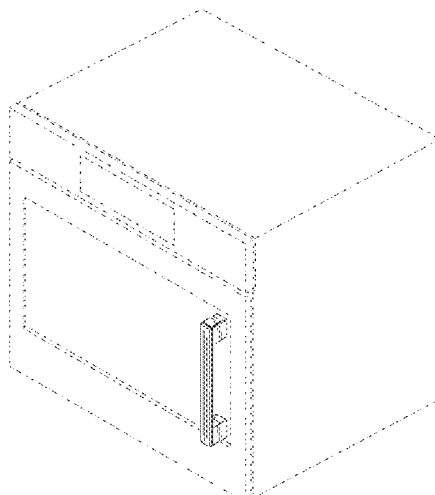

(56)

References Cited

U.S. PATENT DOCUMENTS

| | | | | |
|--------------|---------|-------------|-------|--------|
| D745,311 S * | 12/2015 | Funnell, II | | D7/349 |
| D747,912 S * | 1/2016 | Funnell, II | | D7/348 |
| D747,948 S * | 1/2016 | Funnell, II | | D8/315 |
| D748,424 S * | 2/2016 | Funnell, II | | D7/348 |
| D750,413 S * | 3/2016 | Funnell, II | | D7/348 |
| D750,414 S * | 3/2016 | Funnell, II | | D7/348 |
| D751,854 S * | 3/2016 | Funnell, II | | D7/349 |
| D762,415 S * | 8/2016 | Chung | | D7/405 |
| D784,751 S * | 4/2017 | Funnell, II | | D7/348 |
| D784,752 S * | 4/2017 | Funnell, II | | D7/348 |
| D785,399 S * | 5/2017 | Funnell, II | | D7/349 |
| D786,611 S * | 5/2017 | Funnell, II | | D7/348 |

* cited by examiner

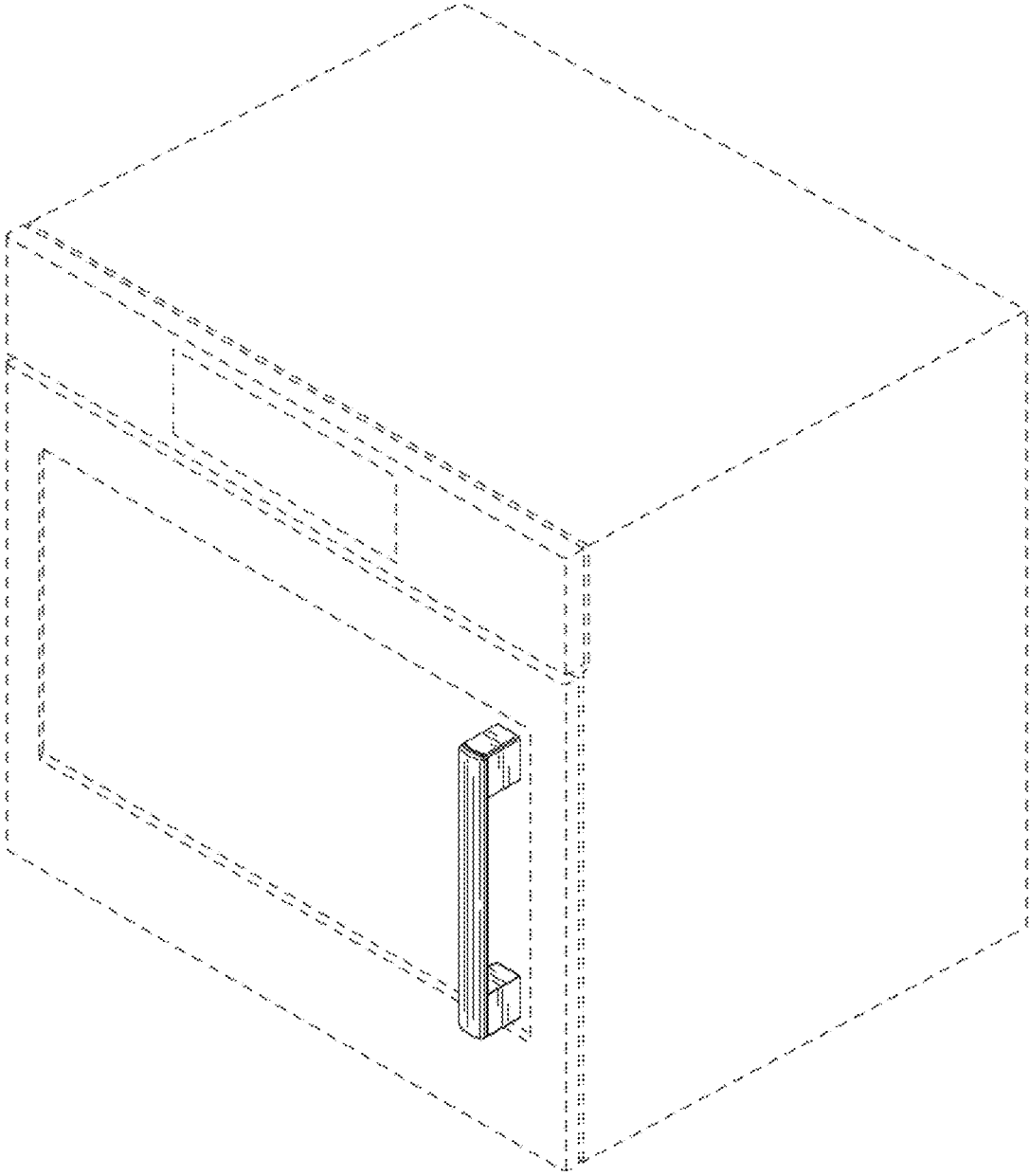

FIG. 1

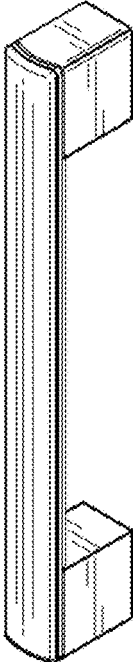

FIG. 2



FIG. 3

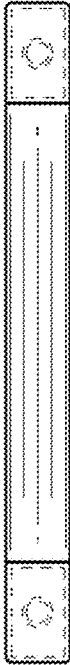

FIG. 4



FIG. 5

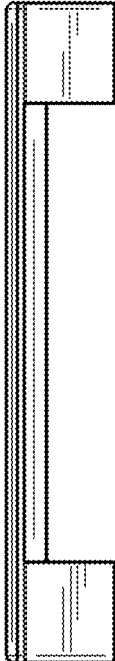

FIG. 6