

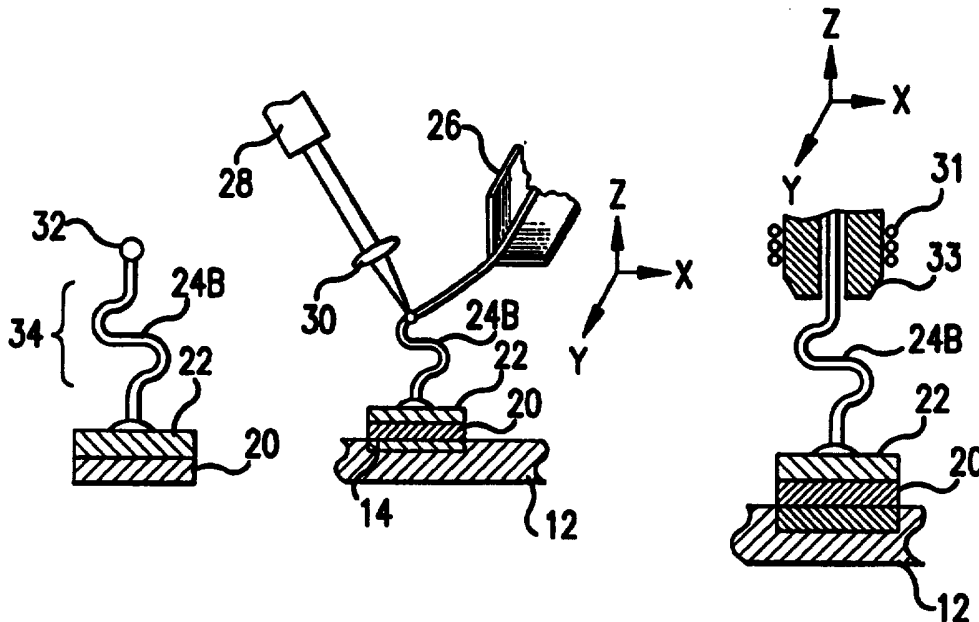

INTERNATIONAL APPLICATION PUBLISHED UNDER THE PATENT COOPERATION TREATY (PCT)

<p>(51) International Patent Classification ⁶ : H01L 21/66, 23/498, 23/49, 21/60</p>	<p>A1</p>	<p>(11) International Publication Number: WO 96/14659 (43) International Publication Date: 17 May 1996 (17.05.96)</p>
<p>(21) International Application Number: PCT/US95/14482 (22) International Filing Date: 6 November 1995 (06.11.95) (30) Priority Data: 08/335,262 7 November 1994 (07.11.94) US (71) Applicant: MICRON TECHNOLOGY, INC. [US/US]; 8000 S. Federal Way, Boise, ID 83706-9632 (US). (72) Inventors: FARNWORTH, Warren, M.; P.O. Box 2004, S. Banner, Nampa, ID 83686-7271 (US). AKRAM, Salman; Apartment #33, 3713 Gekeler Road, Boise, ID 83706 (US). WOOD, Alan, G.; 1366 E. Versailles Court, Boise, ID 83706 (US). (74) Agent: FLETCHER, Michael, G.; P.O. Box 4433, Houston, TX 77210 (US).</p>		<p>(81) Designated States: AL, AM, AT, AU, BB, BG, BR, BY, CA, CH, CN, CZ, DE, DK, EE, ES, FI, GB, GE, HU, IS, JP, KE, KG, KP, KR, KZ, LK, LR, LS, LT, LU, LV, MD, MG, MK, MN, MW, MX, NO, NZ, PL, PT, RO, RU, SD, SE, SG, SI, SK, TJ, TM, TT, UA, UG, UZ, VN, European patent (AT, BE, CH, DE, DK, ES, FR, GB, GR, IE, IT, LU, MC, NL, PT, SE), OAPI patent (BF, BJ, CF, CG, CI, CM, GA, GN, ML, MR, NE, SN, TD, TG), ARIPO patent (KE, LS, MW, SD, SZ, UG). Published <i>With international search report. Before the expiration of the time limit for amending the claims and to be republished in the event of the receipt of amendments.</i></p>

(54) Title: METHOD FOR FORMING CONTACT PINS FOR SEMICONDUCTOR DICE AND INTERCONNECTS



(57) Abstract

A method for forming contact pins adapted to form an electrical connection with a mating contact location is provided. In a first embodiment, the contact pins are formed on an interconnect used for testing a semiconductor die and are adapted to establish an electrical connection with the bond pads of the die. In a second embodiment, the contact pins are formed directly on the bond pads of a die and can be used for establishing a permanent or temporary electrical connection to the pads. The contact pins include a base portion attached to the die or interconnect, a compliant spring segment, and a contact ball at the tip. The contact pins are formed using a wire bonding process or a welding process in which a metal wire is simultaneously heated and shaped into a compliant structure as it is attached to the die or interconnect.

FOR THE PURPOSES OF INFORMATION ONLY

Codes used to identify States party to the PCT on the front pages of pamphlets publishing international applications under the PCT.

AT	Austria	GB	United Kingdom	MR	Mauritania
AU	Australia	GE	Georgia	MW	Malawi
BB	Barbados	GN	Guinea	NE	Niger
BE	Belgium	GR	Greece	NL	Netherlands
BF	Burkina Faso	HU	Hungary	NO	Norway
BG	Bulgaria	IE	Ireland	NZ	New Zealand
BJ	Benin	IT	Italy	PL	Poland
BR	Brazil	JP	Japan	PT	Portugal
BY	Belarus	KE	Kenya	RO	Romania
CA	Canada	KG	Kyrgystan	RU	Russian Federation
CF	Central African Republic	KP	Democratic People's Republic of Korea	SD	Sudan
CG	Congo	KR	Republic of Korea	SE	Sweden
CH	Switzerland	KZ	Kazakhstan	SI	Slovenia
CI	Côte d'Ivoire	LI	Liechtenstein	SK	Slovakia
CM	Cameroon	LK	Sri Lanka	SN	Senegal
CN	China	LU	Luxembourg	TD	Chad
CS	Czechoslovakia	LV	Latvia	TG	Togo
CZ	Czech Republic	MC	Monaco	TJ	Tajikistan
DE	Germany	MD	Republic of Moldova	TT	Trinidad and Tobago
DK	Denmark	MG	Madagascar	UA	Ukraine
ES	Spain	ML	Mali	US	United States of America
FI	Finland	MN	Mongolia	UZ	Uzbekistan
FR	France			VN	Viet Nam
GA	Gabon				

5

10 **METHOD FOR FORMING CONTACT PINS FOR
SEMICONDUCTOR DICE AND INTERCONNECTS**

15 This invention relates generally to semiconductor manufacture and more particularly to a method for forming compliant metal contact pins on active semiconductor dice and silicon interconnects. The contact pins are particularly suited to testing unpackaged die in the manufacture of known good die (KGD).

20 Bare or unpackaged semiconductor dice are used extensively in the manufacture of electronic devices. Known-good-die (KGD) is a collective term that connotes unpackaged dice having the same quality and reliability as the equivalent packaged product. The demand for known-good-die has led to the development of test procedures for testing unpackaged semiconductor dice.

25 For test and burn-in of an unpackaged die, a carrier replaces a conventional single chip package in the testing process. The carrier typically includes an interconnect element that allows a temporary electrical connection to be made between the die and external test circuitry. In addition, such a carrier must allow the necessary test procedures to be performed without damaging the die. The
30 bond pads on a die are particularly susceptible to damage during the test procedure.

 Recently semiconductor manufacturers have developed carriers for testing discrete, unpackaged die. Different types of carriers are disclosed in U.S. Patent

No. 4,899,107 to Corbett et al. and U.S. Patent No. 5,302,891 to Wood et al., which are assigned to Micron Technology, Inc., and in U.S. Patent No. 5,123,850 to Elder et al., and U.S. Patent No. 5,073,117 to Malhi et al., which are assigned to Texas Instruments.

5

One of the key design considerations for a carrier is the method for establishing a temporary electrical connection with contact locations on the die. These contact locations are typically pads such as bond pads or test pads located on the face of the die. With some carriers, the die is placed face down in the carrier and biased into contact with an interconnect. The interconnect contains the contact structure that physically contacts and forms an electrical connection with the die pads. Exemplary contact structures include wires, needles, and bumps. The mechanisms for making electrical contact include piercing the native oxide of the die pad with a sharp point, breaking or burnishing the native oxide with a bump, or scrubbing the native oxide with a contact adapted to move across the die pad.

10
15

These different contact structures are designed to establish an electrical connection with the bond pads of a die under test. Preferably this connection is low-resistance and ohmic. Low-resistance connotes a resistance that is negligible. An ohmic connection is one in which the voltage appearing across the connection is proportional to the current flowing for both directions of current flow. In the past it has been difficult to establish a low-resistance ohmic connection with bond pads while minimizing damage to the pads. A bond pad may only be about 1μ thick and is thus relatively easy to damage. In general, each of the above noted contact structures will displace the bond pad metallization and damage the pad.

20
25

In addition to forming a low-resistance ohmic connection, it is also desirable for a contact structure to be compliant in nature. Sometimes an arrangement of bond pads may present a sloped or irregular surface topography. This may be due to the mounting arrangement of the die in the carrier or to the

30

uneven topography of the bond pads across the surface of the die. It is thus advantageous to form the interconnect with compliant contacts adapted to conform to the vertical location of the bond pad. In a similar manner, it is desirable for the contact to possess a resiliency which permits it to return to its original position for reuse.

In view of the foregoing, there is a need in the art for improved contact structures for testing and manufacturing semiconductor dice. Accordingly, it is an object of the present invention to provide a method for forming metal contact pins suitable for testing unpackaged semiconductor dice.

It is a further object of the present invention to provide an improved contact structure that can be used to form contacts for temporary interconnects and can also be used to form contacts on an active semiconductor dice.

It is yet another object of the present invention to provide an improved metal contact pin that is compliant, resilient and adapted to form a temporarily electrical connection with a bond pad without damage to the die.

Other objects, advantages, and capabilities of the present invention will become more apparent as the description proceeds.

In accordance with the present invention an improved contact structure and a method for forming the contact structure are provided. The contact structure, simply stated, comprises metal contact pins attached to a substrate. In a first embodiment of the invention the substrate is a silicon interconnect and the contact pins are attached to the interconnect in electrical communication with conductive traces. In a second embodiment, the substrate is an active semiconductor die and the contact pins are attached to die pads (e.g., bond pads, tests pads) on the die. In either case, the contact pins are suitable for forming an electrical connection with a mating contact location that is low resistance and ohmic.

The contact pins are formed with a compliant structure to permit flexure as the contact pins are biased against the mating contact location to form an electrical connection. As an example, an interconnect having contact pins and a die having flat bond pads may be placed together in a test carrier. As the interconnect and die are biased together in the carrier, the contact pins on the interconnect form an electrical connection with the bond pads on the die. The compliant structure of the contact pins permits flexure to accommodate variations in the mating topographies. The compliant structure can include a flexible spring segment for the contact pins or an angled mounting arrangement for the contact pins. In addition, the contact pins can include a contact ball on the end to facilitate the formation of an electrical connection.

There are two preferred methods for attaching the contact pins to the die pads of a semiconductor die or to the substrate of an interconnect. These attachment methods are wire bonding and welding. During the attachment process, the contact pins are formed with a compliant structure, such as a spring segment, using localized heating and bending. Localized heating and bending can be accomplished with a laser working in conjunction with a wire bonder or a welding tool. A heated capillary wire feed system can also be used to heat and bend the contact pins during the attachment process. The contact ball is preferably formed on an end of each contact pin at the completion of the attachment process.

Figures 1A-1E are schematic cross sectional drawings illustrating the steps in forming contact pins on a semiconductor die in accordance with the invention using a wire bonding process;

25

Figure 2 is a schematic cross sectional drawing of contact pins wire bonded to a semiconductor die at an angle to provide a compliant contact structure;

Figure 3A is a schematic view illustrating a contact pin having a compliant structure formed as a spring segment;

30

Figure 3B is a schematic view illustrating a heating and shaping process for forming the contact pin of Figure 3A which uses a laser and wire bonding tool;

5 Figure 3C is a schematic view illustrating a heating and shaping process for forming the contact pin of Figure 3A which uses a heated capillary tool;

Figures 4A and 4B illustrate alternate embodiment contact pins having compliant structures formed as spring segments;

10 Figures 5A-5E are schematic cross sectional drawings illustrating steps in forming contact pins on a semiconductor die in accordance with the invention using a welding process;

15 Figure 6A is a perspective view of an interconnect having contact pins formed in accordance with the invention;

Figure 6B is an enlarged view of a portion of Figure 6A;

20 Figure 6C is an enlarged cross sectional view of a contact pin mating with a flat bond pad on a semiconductor die to establish an electrical connection;

25 Figure 7A is a schematic drawing illustrating a portion of an interconnect having contact pins formed in accordance with the invention with a spring segment;

30 Figure 7B is a schematic drawing illustrating a portion of an interconnect having contact pins formed in accordance with the invention and mounted at an angle with respect to a substrate of the interconnect to provide a compliant structure; and

30

Figure 8 is a perspective view of an interconnect having two different embodiments of contact pins formed in accordance with the invention.

Referring now to Figures 1A-1E the method of the invention is illustrated
5 for forming contact pins on an active semiconductor die 10. As shown in Figure 1A, the semiconductor die 10 is a conventional die that includes a silicon substrate 12 on which integrated circuits have been formed. Bond pads 14 are in electrical communication with the integrated circuits. During the manufacturing process the die 10 is fabricated on a wafer with a large number of other dice. Each die 10 on
10 the wafer can subsequently be singulated by saw cutting.

The bond pads 14 of the die 10 are embedded in a passivation layer (not shown). The bond pads 14 are typically polygonal (e.g.i square) metal pads, about $100\mu\text{m}$ on a side, which are separated by a space of about 50 to $100\mu\text{m}$.
15 Typically, the bond pads 14 are formed of aluminum (Al) using a metallization process. Metals other than aluminum are sometimes used to form the bond pads on a semiconductor die but aluminum is most prevalent. The aluminum bond pads 14 are used for establishing an electrical connection between the integrated circuits on the die and the outside world. Depending on the application, an electrical
20 connection to the bond pads is made using various methods such as wire bonding, tape automated bonding or flip chip bonding. The present invention allows this connection to be made using a contact pin formed with a compliant structure.

Initially, as shown in Figure 1B, a layer of photoresist 16 is spun onto the
25 wafer containing the die 10. The layer of photoresist 16 is exposed, developed and etched to form a mask having openings 18. The openings 18 are in alignment with the bond pads 14 and have the same peripheral configuration as the bond pads 14.

30 Next, as shown in Figure 1C, an intermediate pad 20, formed of a conductive material such as copper, is deposited in the openings 18 and onto the

bond pads 14. The intermediate pad 20 is on the order of $1\ \mu\text{m}$ to $50\ \mu\text{m}$ in thickness and is approximately the same size as the bond pads 14. The purpose of the intermediate pad 20 is to allow a solder pad 22 (Figure 1D), formed of a solderable material such as nickel, to be attached to the aluminum bond pad 14.

5 Although the solder pad 22 can be deposited directly to the aluminum bond pad 14, the intermediate pad 20 formed of a material such as copper, bonds more readily to the aluminum bond pad 14.

The intermediate pad 20 is deposited using an electroless electrolytic

10 plating process. Various metal films including copper (Cu), nickel (Ni), gold (Au) and palladium (Pd) can be deposited through electroless deposition using aqueous solutions comprising metal ions and reducing agents. Electroless plating is often used to form contacts by filling a via with a deposited metal. As an example, in the present application for depositing Cu on Al, the aqueous base solution contains

15 Cu^{++} ions and ascorbic acid reducing agents. The intermediate pad 20 is plated onto the bond pad 14 to a thickness that is less than the thickness of the layer of photoresist 16. This permits the same opening 18 to be used for a subsequent plating process.

20 Next, as shown in Figure 1D, the solder pad 22 is deposited on the copper pad 20. The solder pad 22 may also be deposited using an electroless plating process. As an example, an aqueous solution containing Ni^{+} ions and dimethyl aminoborane reducing agents can be used to deposit a nickel solder pad 22. The solder pad 22 has a thickness of from $1\ \mu\text{m}$ to $50\ \mu\text{m}$ and an outer peripheral

25 configuration that matches the intermediate pad 20 and the aluminum bond pad 14. The solder pad 22 is formed of a material that can be easily soldered such as nickel, nickel alloys or gold.

Next, as shown in Figure 1E, a contact pin 24 is attached to the solder pad

30 22. The contact pin 24 is formed of wire having a thickness of about 1 to 5 mils. Suitable materials for the contact pin 24 include copper, gold, nickel alloys and

spring steel alloys. The contact pin 24 is attached to the solder pad 22 using a wire bonding apparatus. The contact pin 24 may be bonded directly to the solder pad 22 or a solder material 25 may be used during the wire bonding process.

5 Wire bonding apparatus are well known in the art. Wire bonding apparatus are manufactured by Kulicke and Soffa Industries, Inc., Horsham, PA and Mitsubishi Denki, Japan. U.S. Patent No. 3,894,671 to Kulicke, Jr. et al. and U.S. Patent No. 4,877,173 - to Fujimoto et al. disclose representative wire bonding apparatus.

10

 During the wire bonding process the end of the wire which forms the base 25 (Figure IE) of the contact pin 24, is heated by an electrical discharge or a hydrogen torch to a molten state. This forms a ball of molten metal on the base 25 of the contact pin 24. The molten ball is then pressed by a bonding tool
15 against the solder pad 22. Ultrasonic vibrations are also applied to the molten ball as it is pressed against the solder pad 22. This mechanically bonds the wire to the solder pad 22. The wire is then electrically opened or sheared to form the contact pin 24.

20

 Following the wire bonding process the layer of photoresist 16 can be stripped from the substrate 12. Depending on the photoresist formulation this can be accomplished using a suitable wet chemical stripper. In addition, a protective layer (not shown) can then be applied to the substrate 12 to protect the surface of the substrate and limit the stresses applied to the contact pin substrate interface
25 from the motion of the contact pins 24.

 With reference to Figure 2, a compliant structure can be achieved by positioning the contact pin 24A at an acute angle with respect to the plane of the substrate 12. The contact pin 24 is thus able to flex as indicated by arrows 26 as
30 it is biased against a mating component (e.g., a contact on a printed circuit board).

The contact pin 24A may be positioned at an angle by appropriate manipulation of the bonding tool of the wire bonding apparatus.

With reference to Figures 3A and 3B, a technique for forming another
5 compliant contact structure for a contact pin 24B is shown. As shown in Figure
3A, the contact pin 24B includes a compliant structure formed as a spring segment
34. In addition, the contact pin 24B includes a contact ball 32 on the end. The
contact ball 32 facilitates electrical connection of the contact pin 24B with a
mating contact location, such as a pad, formed on an interconnect or other
10 substrate (e.g., circuit board).

Figure 3B illustrates a process for forming the shaped contact pin 24B with
a compliant spring segment 34. In an automated wire bonding apparatus,
movement of a wire bonding tool 26 in the x, y and z directions is under computer
15 control. Using appropriate software, the wire bonding tool 26 can be moved in a
path to manipulate a length of wire to form the spring segment 34 (Figure 3A).
The spring segment 34 includes a flat s-shaped segment as shown, or may be
formed with multiple coils twisted into a spiral. At the same time that the wire
bonding tool 26 is moving a length of wire through a specified path, a laser 28
20 focused through a lens 30 initiates localized heating of the wire. This softens the
wire material so that it can be formed into the desired shape, which upon cooling
will be permanent. The laser 28 or an electrical discharge arrangement or
separate shearing member, is then operated to clip the wire. The contact ball 32
(Figure 3A) is formed using the laser 28 to heat the end of the contact pin 24B
25 and form a molten ball. Alternately, the electrical discharge arrangement or a
hydrogen torch can be used to form the contact ball 32 (Figure 3A) at the end of
the contact pin 24B.

Figure 3C illustrates another technique for heating and shaping a length of
30 wire using a heated capillary wire feed system. This technique is essentially the
same as that previously explained for Figure 3B. In this case, a capillary tool 33

having a heating element 31 is moved in a path to manipulate the length of wire for shaping. One suitable heated capillary tool 33 is manufactured by Kulicke and Soffa Industries, Inc., 507 Prudential Road, Horsham, PA 19044 and is a component of a wire bonding apparatus.

5

Figures 4A and 4B illustrate alternate embodiment contact pins 24C and 24D. In Figure 4A, the contact pin 24C is formed with a spring segment 38 that has multiple s-shaped segments. In Figure 4B a contact pin 24D is formed with a spring segment 40 having multiple s-shaped segments that are wider at the base.

10 In each case the spring segment 38 may be flat, as shown or formed with a spiral twist.

Referring now to Figures 5A-5E an alternate embodiment process for forming contact pins on the semiconductor die 10 is shown. The alternate

15 embodiment process attaches contact pins 24W (Figure 5E) to the bond pads 14 of the die 10 using welding rather than wire bonding.

Initially a shorting layer 36 is blanket deposited over the substrate 12 and bond pads 14 of the semiconductor die 10. The shorting layer 36 is preferably
20 formed of a highly conductive material such as copper. Other suitable materials include nickel or aluminum. The shorting layer is deposited using a suitable metallization process such as electrolytic plating, chemical vapor deposition or sputtering. The shorting layer 36 functions as an electrical path for a welding current. This helps to shunt the welding current away from the integrated circuits
25 which may be adversely affected by the.

Next, as shown in Figure 5B, a layer of photoresist 42 is deposited on the shorting layer 36. The layer of photoresist 42 is developed and etched to form a mask having a pattern of openings 44. Each opening 44 extends through the layer
30 of photoresist 42 to the shorting layer 36 and is aligned with a bond pad 14 of the die 12.

Next, as shown in Figure 5C weld pads 46 are deposited in the openings 44 and onto the shorting layer 36. The weld pads 46 are deposited using an electroless deposition process as previously described. The weld pads 46 are formed of a material that can be easily welded. Suitable materials include nickel, gold and copper.

Next as shown in Figure 5D, contact pins 24W are welded to the weld pads 46 using a welding process. In some embodiments the weld pads 46 are not required as the contact pins 24W can be welded directly to the shorting layer. Welding apparatus for semiconductor manufacture are similar in construction to wire bonding apparatus and are used for the same purposes. Suitable welding apparatus are manufactured by the previously identified wire bonder manufactures. With minor modifications to the electrical circuitry, flame-off components and grounding of the workholder, such a wire bonding apparatus can be modified to perform the functions previously outlined in Figures 3D and 3C (i.e., heating and shaping).

In general, a welding apparatus uses an electric current to generate the heat necessary to form molten material at the interface of two metals. For the present application the welding current is passed through the contact pins 24W and to the weld pads 46. The shorting layer 36 provides a closed loop to carry the current through all of the weld pads 46 formed on the die 10. The welding current forms molten metal at the interface of each contact pin 24W and its respective weld pad 46 and bonds these elements together.

Next as shown in Figure 5E, the layer of photoresist 42 is stripped. In addition, the shorting layer 36 is patterned and etched so that base pads 48 are formed. This forms a stacked structure on each aluminum bond pad 14 which includes the base pad 48, the weld pad 46 and the welded contact pin 24W. In addition, a protective layer (not shown) can be applied to protect the surface of the substrate 12 and limit the stresses applied to the contact pin-weld spot interface

from the motion of the contact pin 24W. During the welding process, the contact pins 24W can be angled to form a compliant structure as previously described. In addition, compliant structures comprising spring segments may be formed substantially as previously described by simultaneously heating and moving a length of wire which forms the contact pin 24W.

Referring now to Figures 6A and 6B, an interconnect 50 having contact pins 56 formed in accordance with the invention is shown. The interconnect 50 includes a substrate 52 and a pattern of circuit traces 54 formed on the substrate 52 as an aid in constructing and subsequently using the interconnect 50. The circuit traces 54 can be formed by depositing and patterning a conductive metal. A pattern of alignment fiducials 53 is also formed on the substrate 52.

A preferred material for the substrate 52 is silicon which will have the same coefficient of thermal expansion as a silicon die. Other suitable materials include ceramic and silicon on sapphire. The interconnect 50 is adapted for use with a carrier for testing bare or unpackaged semiconductor dice. The interconnect 50 is adapted to establish temporary electrical communication between a semiconductor die retained in the carrier and external test circuitry. U.S. Patent No. 5,302,891 to Wood et al. entitled "Discrete Die Burn-In For Nonpackaged Die" discloses a carrier that uses an interconnect.

In use, the interconnect 50 is placed within a test carrier, along with a die, and the contact pins 56 formed on the interconnect 50 are placed in contact with the bond pads on the die to establish an ohmic contact. The circuit traces 54 of the interconnect are then placed in electrical communication with external test circuitry. As an example, the circuit traces 54 may be wire bonded to external connectors on the carrier which connect to the test circuitry.

As shown in Figure 6B, the contact pins 56 are formed on the circuit traces 54. The circuit traces 54 are formed of a conductive material such as a thick film

metal which is patterned as it is deposited on the substrate 52 (e.g., screen printing). As shown in Figure 6C, the contact pin 56 includes a c-shaped segment 64. In addition, the contact pin 56 includes a base portion 68 that attaches to the circuit trace 54 and a tip portion 66 adapted to contact a bond pad 70 of a die under test. The contact pins 56 may be formed substantially as previously described using a wire bonding process or a soldering process. Exemplary dimension for the contact pins include a diameter of 1 to 5 mils and a height of from 3 to 10 mils.

10 Referring now to Figures 7A-7C, alternate embodiment interconnects having contact pins formed in accordance with the invention are shown. In Figure 7A, an interconnect 50A includes a silicon substrate 52A, a circuit trace 54A and a contact pin 60. The contact pin 60 is formed on the circuit trace 54A using a wire bonding process substantially as previously described. The contact pin 60 includes a base portion 76 attached to the circuit trace 54A, a spring segment 72 and a contact ball 62 formed on the end for contacting a bond pad of a die under test. The ball 62 is formed using a gas flame (e.g., hydrogen gas) or electrical discharge as previously described.

20 In Figure 7B an interconnect 50B includes a silicon substrate 52B, a circuit trace 54B and contact pin 60B. In addition, the contact pin 60B includes a base portion 78 and a contact ball 62B for contacting the bond pad of a die under test. In this case, a compliant structure is achieved by attaching the contact pin 60B at an acute angle to the substrate 52B. In other words, the axis of the contact pin 60B is situated at an acute angle with respect to the plane of the substrate 52.B. Furthermore, contact pin 60B rather than being attached directly to the circuit trace 54B, attaches to the circuit trace via a bond site 74 formed on the circuit trace 54B. The bond site 74 is a conductive layer, preferably a metal such as nickel, that is plated or deposited on the circuit trace 54B. As before, the contact ball 62B is formed using a gas flame or electrical discharge.

In Figure 8, an interconnect 50C includes a silicon substrate 52C, circuit traces 54C formed on the substrate 52C and two types of contact pins 56 and 58 formed on the circuit traces 54C. The contact pins 56 have been previously described. Contact pins 58 are straight pins adapted for connection to a socket or female member. In use of the interconnect 50C in a test carrier for a die under test, the contact pins 56 are placed in contact with contact locations on the die. Contact pins 58 are placed in contact with external test circuitry.

Thus the invention provides a method for forming contact pins suitable for use as contacts on active semiconductor dice or contacts on interconnects useful for testing unpackaged semiconductor dice. The contact pins preferably include a compliant structure to permit flexure during the formation of an electrical connection with a contact location on a mating component.

Although the invention has been described in terms of preferred embodiments, it is intended that alternate embodiments of the inventive concepts expressed herein be included within the scope of the following claims.

CLAIMS:

1. A method for forming a contact structure on an interconnect, said contact structure adapted to establish an electrical connection with a contact location on a semiconductor die, comprising:
 - 5 providing a substrate;
 - 10 attaching a wire to the substrate;
 - 15 heating and shaping the wire into a compliant structure; and
 - 20 severing the wire to form a contact pin.
2. The method as claimed in claim 1 and wherein:
 - 25 attaching the wire to the substrate is by wire bonding.
3. The method as claimed in claim 1 and wherein:
 - 30 attaching the wire to the substrate is by welding.
4. The method as claimed in claim 1 and wherein:
 - 35 heating and shaping the wire is with a laser and a wire bonder tool
 - 40 manipulated to bend the wire into a predetermined shape.
5. The method as claimed in claim 1 and wherein:

heating and shaping the wire is with a heated capillary tube.

6. The method as claimed in claim 1 and wherein:

5

the wire is shaped to include a spring segment.

7. The method as claimed in claim 1 and wherein:

10

the wire is shaped with a contact ball on an end thereof.

8. A method for forming a contact pin for an interconnect, said contact pin adapted to establish an electrical connection with a contact location on a semiconductor die, comprising:

15

forming a substrate;

forming a conductive trace on the substrate;

20

forming a metal pin on the substrate in electrical communication with the conductive trace said metal pin formed of a wire that is attached to the substrate and then severed; and

25

heating and shaping the wire as it is attached to the substrate to form a compliant spring segment.

9. The method as claimed in claim 8 and wherein;

30

the compliant spring segment is c-shaped.

10. The method as claimed in claim 8 and wherein:
the compliant spring segment is s-shaped.
5
11. The method as claimed in claim 8 and wherein:
the spring segment is wider at a base.
10
12. The method as claimed in claim 8 and wherein:
the wire is attached to the substrate at an acute angle with respect to a
15 plane of the substrate.
13. The method as claimed in claim 8 and further comprising:
20 forming a contact ball on an end of the length of wire.
14. The method as claimed in claim 8 and wherein:
25 the wire is attached to the substrate by wire bonding the wire to a bond site
formed on the substrate.
15. The method as claimed in claim 8 and wherein:
30 the wire is attached to the substrate by welding.

16. A method for forming a contact pin for an interconnect said contact pin adapted to establish an electrical connection with a contact location on a semiconductor die, comprising:

5

forming a substrate;

forming a conductive trace on the substrate;

10

forming a metal pin on the substrate in electrical communication with the conductive trace said metal pin formed of a wire that is wire bonded to the substrate and then severed; and

15

heating and shaping the wire as it is wire bonded to form the metal pin with a compliant spring segment.

17. The method as claimed in claim 16 and wherein;

20

heating and shaping the wire is by manipulating a wire bonding tool while a laser heats the wire.

18. The method as claimed in claim 16 and wherein:

25

heating and shaping the wire is by manipulating a capillary tube having a heating element.

30

19. The method as claimed in claim 16 and wherein:

the spring segment is attached to the substrate at an acute angle with respect to a plane of the substrate.

5 20. The method as claimed in claim 16 and wherein:

the spring segment is wider at a base than at a tip.

10 21. The method as claimed in claim 16 and further comprising:

forming a ball on an end of the wire.

15 22. The method as claimed in claim 16 and wherein:

the conductive trace includes a bond site and the wire is wire bonded to the bond site.

20

23. A method for forming a contact structure on a semiconductor die, said die including a substrate with integrated circuitry and a die pad in electrical communication with the integrated circuitry, said method comprising:

25 forming a solder pad on the die pad;

attaching a metal wire to the solder pad using a wire bonding process;

heating and shaping the metal wire into a compliant structure as it is wire
30 bonded; and

severing the metal wire to form contact pins on the die pad.

24. The method as claimed in claim 23 and wherein:

5

the metal wire is attached to the substrate at an acute angle with respect to a plane of the substrate to provide the compliant structure.

10 25. The method as claimed in claim 23 and further comprising:

heating and shaping the metal wire with a spring segment as it is attached to the solder pad to provide the compliant structure.

15

26. The method as claimed in claim 23 and further comprising:

forming a contact ball on an end of the metal wire.

20

27. The method as claimed in claim 23 and wherein:

heating the metal wire is with a laser and shaping the metal wire is by manipulating a wire bonding tool.

25

28. The method as claimed in claim 23 and wherein:

heating and shaping the metal wire is with a heated capillary tool.

30

29. A method for forming a contact structure on a semiconductor die having a plurality of die pads in electrical communication with integrated circuitry formed on the die, said method comprising:

5 forming a mask on the substrate having an opening aligned with the die pads;

forming a shorting layer on the substrate to electrically connect the die pads;

10

forming welding pads in the openings in electrical contact with the die pads;

attaching metal wires to the welding pads using a welding process;

15

heating and shaping the metal wires during the welding process into a compliant structure;

severing the metal wire to form contact pins; and

20

removing the shorting layer except in an area in contact with the welding pads.

25

30. The method as claimed in claim 29 and wherein:

the metal wires are attached to the substrate at an acute angle with respect to a plane of the substrate.

30

31. The method as claimed in claim 29 and wherein:

the contact pins are formed with a spring segment during the heating and shaping step.

- 5 32. The method as claimed in claim 29 and further comprising:

 forming a ball on an end of the contact pins.
- 10 33. The method as claimed in claim 29 and wherein:

 heating the metal wire is with a laser.
- 15 34. The method as claimed in claim 29 and wherein:

 heating and shaping the metal wire is with a heated capillary tool.

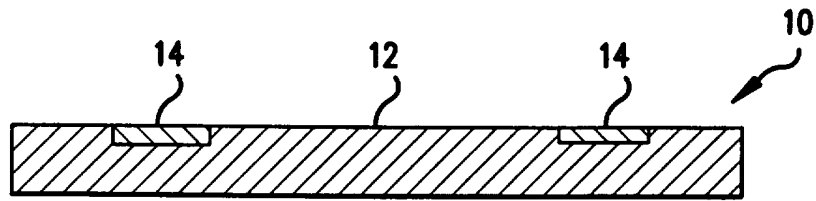

FIG. 1A

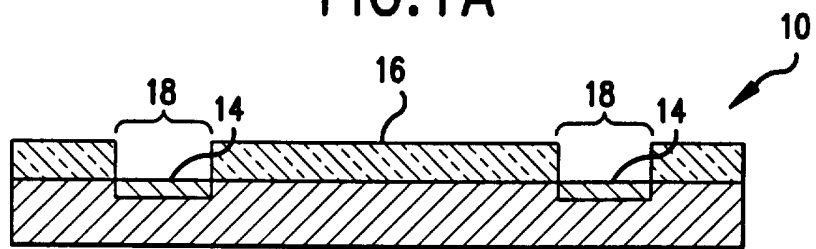

FIG. 1B

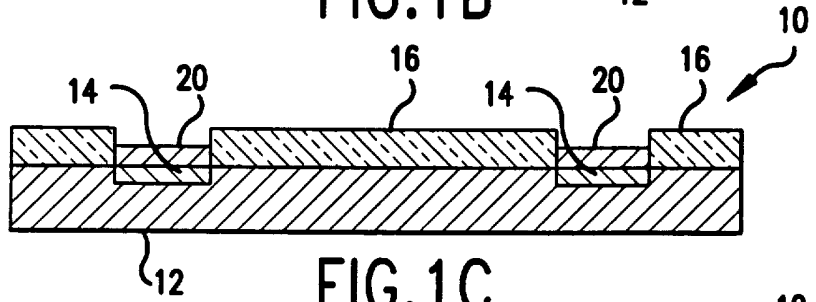

FIG. 1C

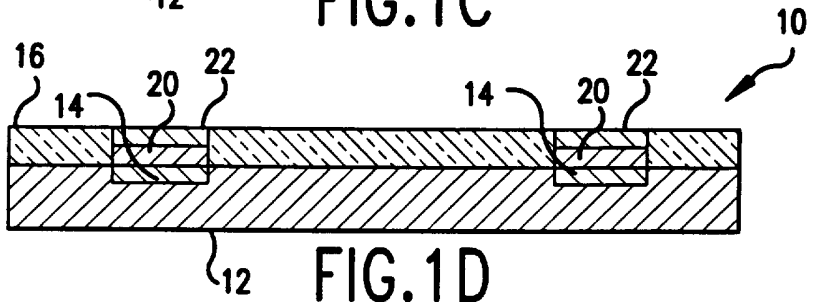

FIG. 1D

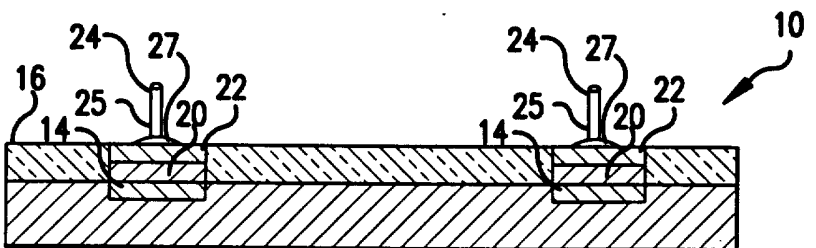

FIG. 1E

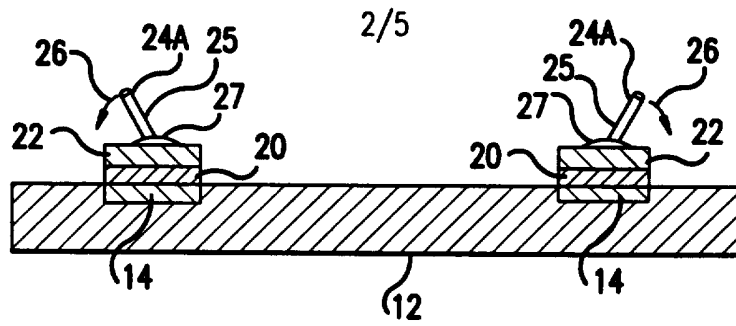

FIG. 2

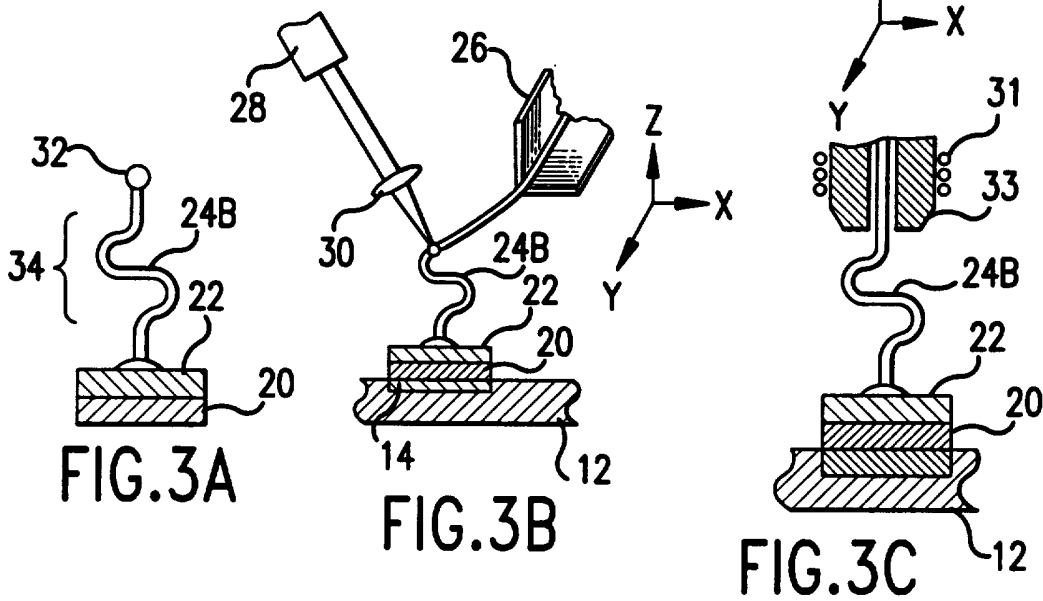

FIG. 3A

FIG. 3B

FIG. 3C

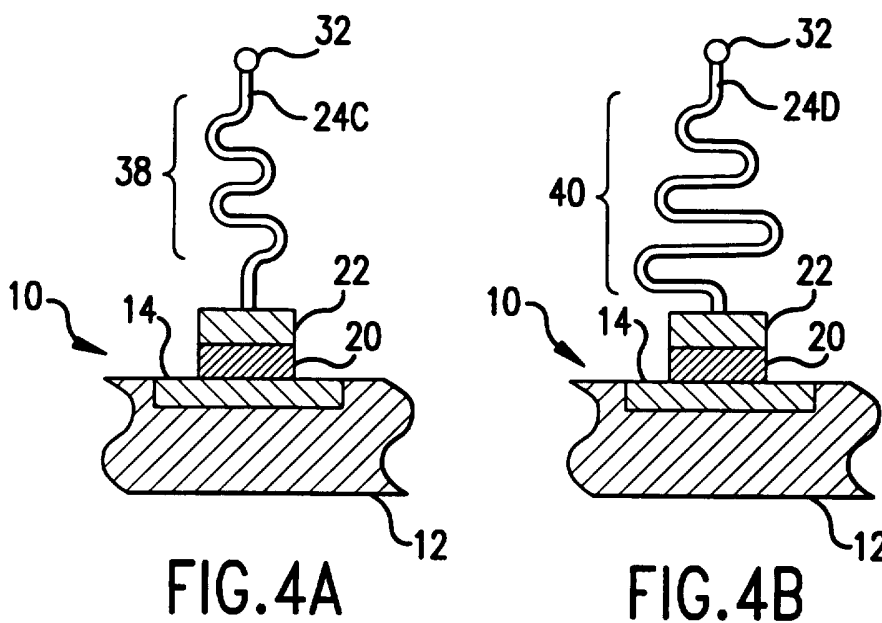
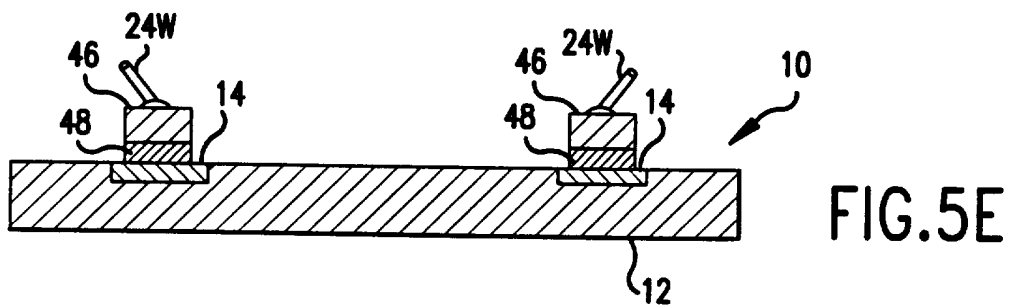
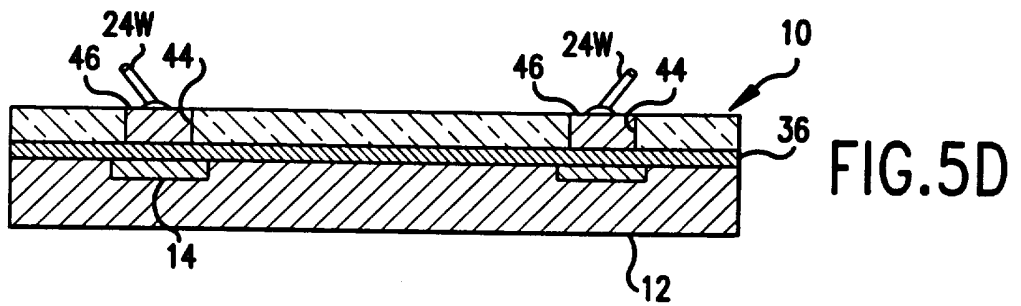
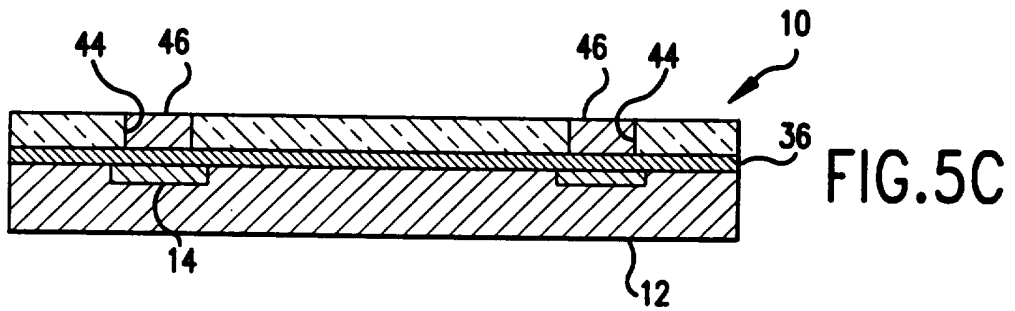
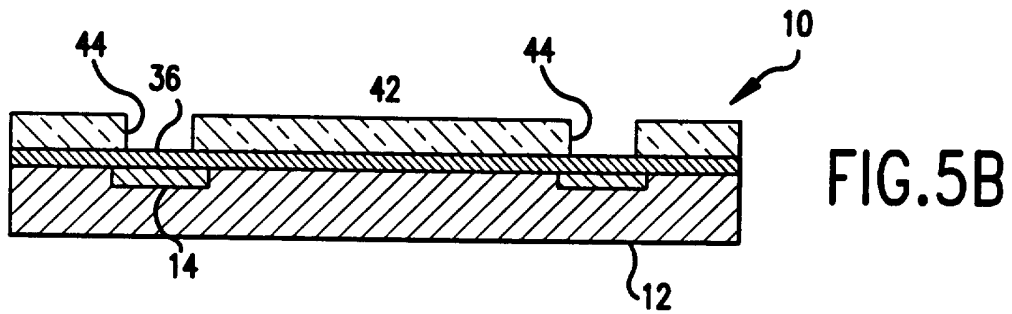
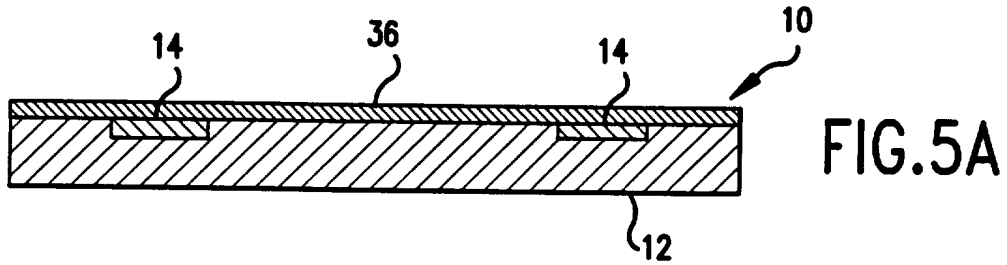

FIG. 4A

FIG. 4B



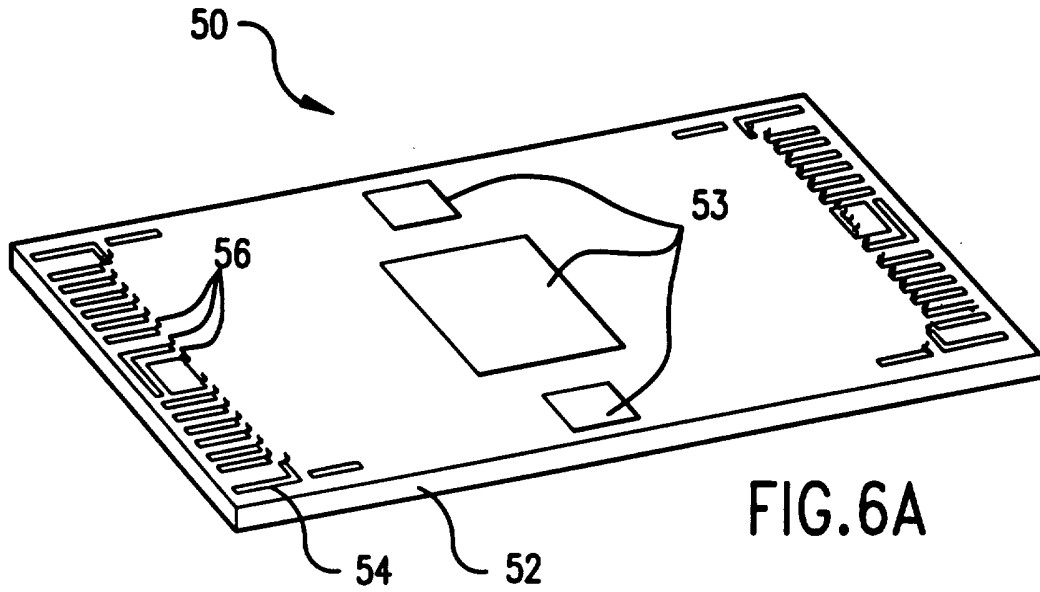

FIG. 6A

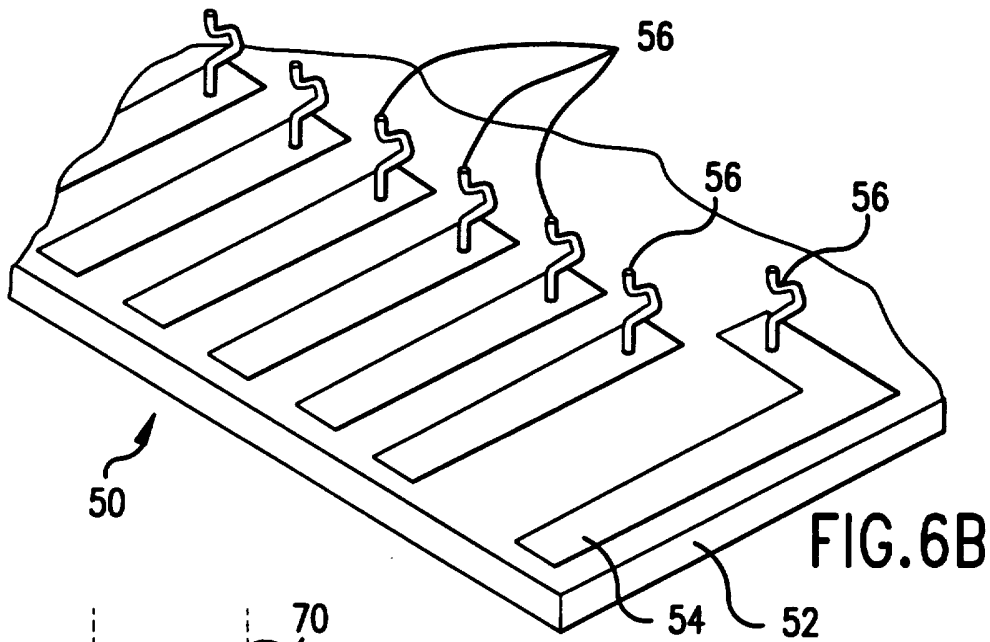

FIG. 6B

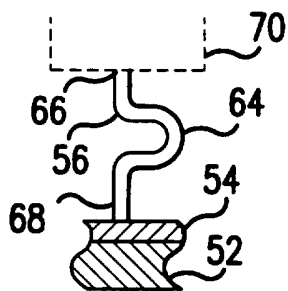

FIG. 6C

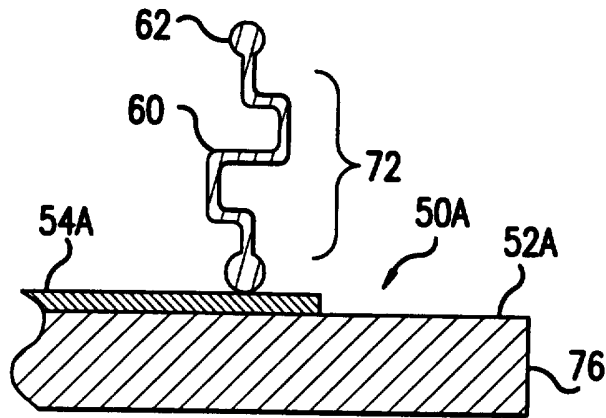

FIG. 7A

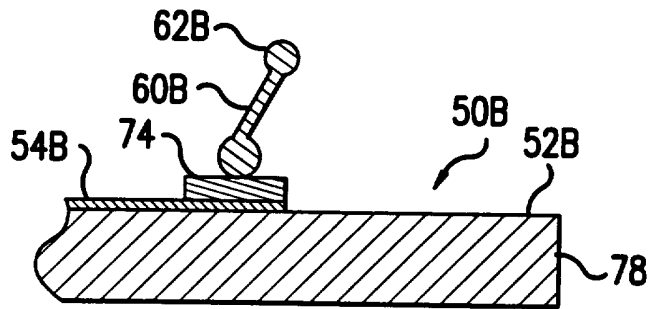

FIG. 7B

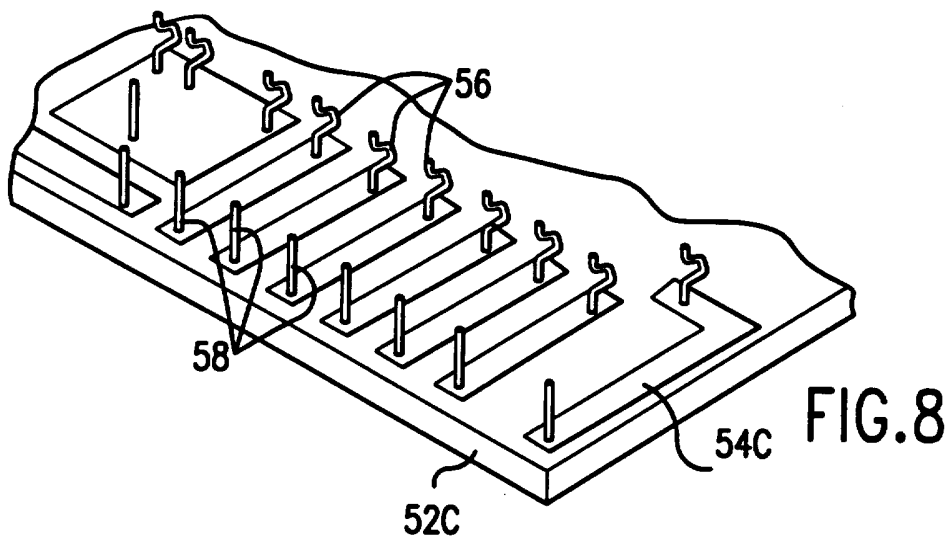

FIG. 8

INTERNATIONAL SEARCH REPORT

International Application No
PCT/US 95/14482

A. CLASSIFICATION OF SUBJECT MATTER
IPC 6 H01L21/66 H01L23/498 H01L23/49 H01L21/60

According to International Patent Classification (IPC) or to both national classification and IPC

B. FIELDS SEARCHED

Minimum documentation searched (classification system followed by classification symbols)
IPC 6 H01L

Documentation searched other than minimum documentation to the extent that such documents are included in the fields searched

Electronic data base consulted during the international search (name of data base and, where practical, search terms used)

C. DOCUMENTS CONSIDERED TO BE RELEVANT

Category *	Citation of document, with indication, where appropriate, of the relevant passages	Relevant to claim No.
X	WO,A,90 11629 (CRAY RESEARCH) 4 October 1990 see the whole document ---	1-3,6-8, 10, 13-16, 21-23, 25,26
X	US,A,4 667 219 (LEE ET AL.) 19 May 1987 see the whole document --- -/--	1-3,6-8, 10, 13-16, 21-23, 25,26

Further documents are listed in the continuation of box C.

Patent family members are listed in annex.

* Special categories of cited documents :

- *A* document defining the general state of the art which is not considered to be of particular relevance
- *E* earlier document but published on or after the international filing date
- *L* document which may throw doubts on priority claim(s) or which is cited to establish the publication date of another citation or other special reason (as specified)
- *O* document referring to an oral disclosure, use, exhibition or other means
- *P* document published prior to the international filing date but later than the priority date claimed

- *T* later document published after the international filing date or priority date and not in conflict with the application but cited to understand the principle or theory underlying the invention
- *X* document of particular relevance; the claimed invention cannot be considered novel or cannot be considered to involve an inventive step when the document is taken alone
- *Y* document of particular relevance; the claimed invention cannot be considered to involve an inventive step when the document is combined with one or more other such documents, such combination being obvious to a person skilled in the art.
- *&* document member of the same patent family

Date of the actual completion of the international search

12 March 1996

Date of mailing of the international search report

21.03.96

Name and mailing address of the ISA
 European Patent Office, P.B. 5818 Patentlaan 2
 NL - 2280 HV Rijswijk
 Tel. (+ 31-70) 340-2040, Tx. 31 651 epo nl,
 Fax: (+ 31-70) 340-3016

Authorized officer

 Prohaska, G

INTERNATIONAL SEARCH REPORT

International Application No
PCT/US 95/14482

C.(Continuation) DOCUMENTS CONSIDERED TO BE RELEVANT

Category *	Citation of document, with indication, where appropriate, of the relevant passages	Relevant to claim No.
X	IBM TECHNICAL DISCLOSURE BULLETIN, vol. 26, no. 1, June 1983 NEW YORK US, page 251 H.W. LORBER ET AL. 'Non-Adhering Probe for Contacting Solder Pads' see the whole document ---	1,8,9
A	US,A,5 158 467 (GRABBE ET AL.) 27 October 1992 see the whole document ---	1-34
A	US,A,5 067 007 (KANJI ET AL.) 19 November 1991 see the whole document ---	1-34
A	US,A,5 130 768 (WU ET AL.) 14 July 1992 ---	
P,X	WO,A,95 14314 (FORMFACTOR) 26 May 1995 see the whole document -----	1-10, 12-16, 18-26,28

INTERNATIONAL SEARCH REPORT

Information on patent family members

International Application No PCT/US 95/14482
--

Patent document cited in search report	Publication date	Patent family member(s)	Publication date
WO-A-9011629	04-10-90	US-A- 5098305 AU-B- 4313389	24-03-92 22-10-90

US-A-4667219	19-05-87	NONE	

US-A-5158467	27-10-92	DE-A- 4236822 FR-A- 2683397 JP-A- 6194412	06-05-93 07-05-93 15-07-94

US-A-5067007	19-11-91	JP-A- 1313969	19-12-89

US-A-5130768	14-07-92	NONE	

WO-A-9514314	26-05-95	US-A- 5476211	19-12-95
