

April 8, 1969

N. S. KHOURY

3,437,229

SOFT LIFT TAB

Filed April 28, 1967

FIG. 1

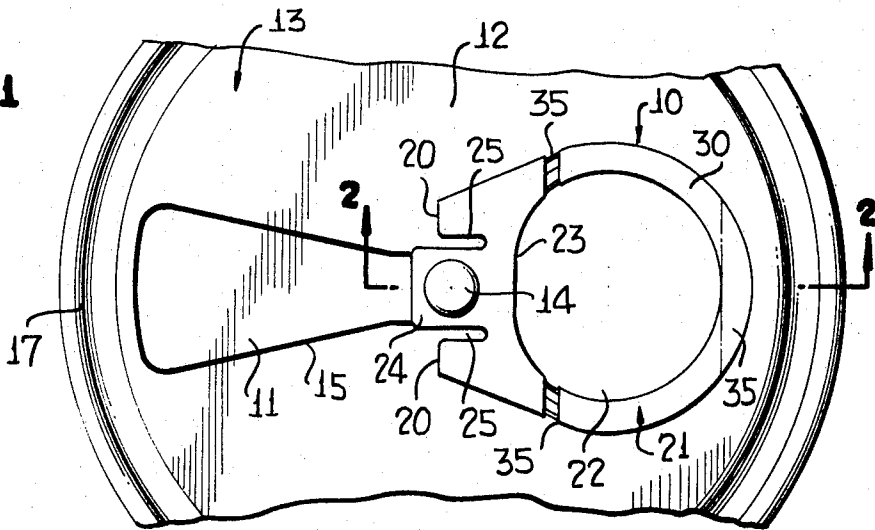

FIG. 2

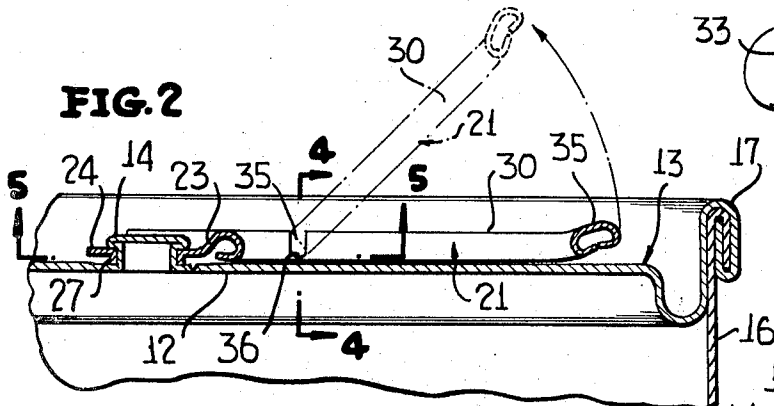

FIG. 4

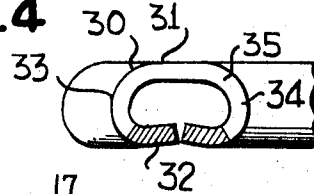

FIG. 3

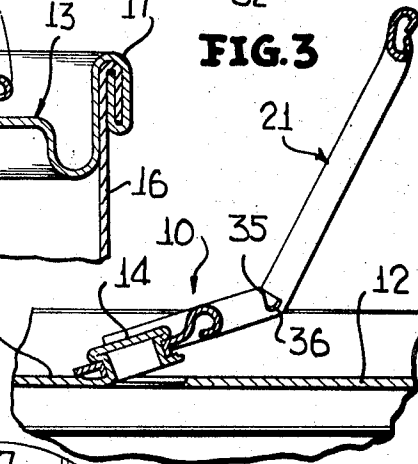

FIG. 5

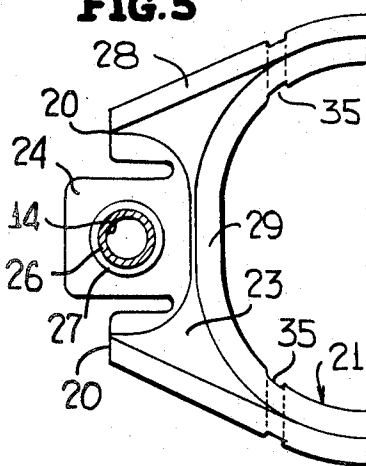
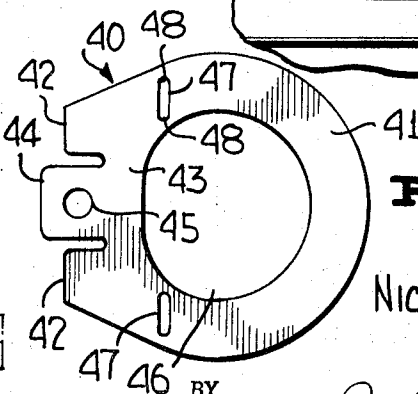

FIG. 6



INVENTOR
NICK S. KHOURY

BY
Mason, Porter, Miller & Brown
ATTORNEYS

1

3,437,229

SOFT LIFT TAB

Nick S. Khoury, Worth, Ill., assignor to Continental Can Company, Inc., New York, N.Y., a corporation of New York

Filed Apr. 28, 1967, Ser. No. 634,661

Int. Cl. B65d 17/20

U.S. Cl. 220—54

11 Claims

2

ABSTRACT OF THE DISCLOSURE

This disclosure has to do with a pull tab for an easy opening container wherein the pull tab is of the lever type and one end thereof must be lifted in order to effect a rupture of the associated container element. The pull tab has a ring portion which is weakened adjacent its connection to the remainder of the pull tab whereby when an initial lifting force is applied to the ring portion, it will bend upwardly a sufficient distance to facilitate the gripping thereof, after which abutment portions will engage to provide a rigid connection between the ring portion and the remainder of the pull tab in the direction of lifting movement.

This invention particularly relates to pull tabs for easy opening containers wherein considerable force is required to effect the initial rupture of container elements. Because the pull tabs are purposely designed to be rigid so they may function as levers, it is quite difficult to initially lift the pull tab so that it may be gripped sufficient to exert the necessary lifting force thereon to effect the rupture of the container element. This is particularly true with respect to small diameter cans wherein that end of the pull tab which is to be lifted is disposed in a recessed position closely adjacent the double seam of the can.

In the past, the above-mentioned deficiencies of pull tabs have been overcome by hingedly connecting the lifting portion of the pull tab to the remainder thereof. However, this has several disadvantages including the fact that the pull tab must be of a two-piece construction which is much more expensive than the single piece construction presently being utilized. Secondly, when there is a hinged connection between the lifting portion and the remainder of the pull tab, the lifting portion functions as no more than a handle and cannot be utilized for the purpose of obtaining maximum leverage.

In view of the foregoing, it is proposed to provide a pull tab which is of a one-piece construction and which may be economically formed from sheet metal in the same manner as pull tabs are presently being formed, but wherein the pull tab has a ring portion which is provided adjacent its connection with the remainder of the pull tab with a transverse line of weakening whereby when an initial lifting force is applied to the ring portion, the ring portion will hinge and bend upwardly relative to the remainder of the pull tab to a position where it may be readily gripped, after which hinging or bending of the ring portion relative to the remainder of the pull tab will cease and the ring portion will form a rigid extension of the remainder of the pull tab in the general direction of movement.

Another object of this invention is to provide a novel pull tab in accordance with the foregoing wherein the line of weakening is in the form of notches which are transversely aligned and which permit the ready bending of the ring portion through a limited angle, after which material disposed on opposite sides of the notches, into abutting engagement and prevent further relative bending.

Another object of this invention is to pre-form the notches prior to the folding of the metal of the pull tab

out of the blank state whereby the notches may be formed simultaneous with the blanking out of the pull tab blank.

With the above and other objects in view that will hereinafter appear, the nature of the invention will be more clearly understood by reference to the following detailed description, the appended claims and the several views illustrated in the accompanying drawings:

In the drawing:

FIGURE 1 is a fragmentary plan view of an end of a can incorporating the pull tab.

FIGURE 2 is an enlarged fragmentary vertical sectional view taken along line 2—2 of FIGURE 1 and shows more specifically the tab formation, the folded position of the ring portion of the tab being shown in phantom lines.

FIGURE 3 is an enlarged fragmentary vertical sectional view generally similar to the left hand portion of FIGURE 2 and showing the pull tab being utilized to effect the initial rupture of the can end.

FIGURE 4 is an enlarged fragmentary transverse vertical sectional view taken along the line 4—4 of FIGURE 2 and shows the specific notching of the pull tab.

FIGURE 5 is an enlarged fragmentary bottom view of the pull tab taken along the line 5—5 of FIGURE 2 and shows more specifically the notch construction.

FIGURE 6 is a plan view on a small scale of the blank from which the pull tab is formed.

Referring now to the drawing in detail, it will be seen that there is illustrated a pull tab which is formed in accordance with this invention, the pull tab being generally referred to by the numeral 10. The pull tab is illustrated in a typical environmental arrangement wherein it is secured to a tear strip portion 11 of an end panel 12 of a can end, which is generally referred to by the numeral 13, by means of a rivet 14 which is integrally formed with the tear strip portion 11. The tear strip portion 11 is defined by a score line 15 which is formed in the end panel 12. The can end 13 closes one end of a can body 16 and is secured to the can body 16 by means of a conventional double seam 17.

The pull tab 10 is intended to function as a lever to exert a sufficient upwardly directed force through the rivet 14 on one end of the tear strip portion 11 to effect an initial rupture of the end panel 12 along that part of the score line 15 which extends about the starting end of the tear strip portion 11.

The pull tab 10 is of a generally horse shoe shaped configuration and terminates at one end in a pair of transversely spaced fulcrums 20. The other end of the pull tab 10 is in the form of a ring portion 21 having a finger receiving opening 22.

The pull tab 10 also has an integral cross bar 23 which is connected to the horse shoe shaped portion thereof intermediate the ring portion 21 and the fulcrums 20 with the cross bar 23 forming a boundary of the ring portion 21. The cross bar 23 has projecting therefrom a connecting portion 24 which is generally strap-like and which is separated from the horse shoe shaped portion of the pull tab by a pair of longitudinally extending notches 25. The connecting portion 24 projects longitudinally beyond the fulcrums 20 and has formed therein an aperture 26 which receives a rivet 14. The aperture 26 is reinforced by a depending annular flange 27.

The pull tab 10 is reinforced by an outer reversely curled peripheral hem 28 and an inner reversely curled peripheral hem 29, the hem 29 being continuous, surrounding the opening 22, and having a portion thereof extending along the cross bar 23. The free edges of the hems 28 and 29 substantially abut one another around a major part of the ring portion 21 whereby the ring portion 21 is defined by a tubular border part, as is best shown in FIGURE 4. The tubular border part is identified by the

numeral 30 and may be considered to include an upper wall 31, a lower wall 32 and a pair of connecting walls 33 and 34.

It is to be noted that the end of the pull tab 10 remote from the fulcrums 20 is disposed closely adjacent the double seam 17. Thus, it is difficult to engage this end of the pull tab 10 to effect the lifting thereof, as is required in the tearing out of the tear strip portion 11. In order to facilitate the initial lifting of the pull tab 10, the extreme end portion of the tubular border part 30 is bent upwardly as at 35. While the tab may be engaged because of this upward offsetting of the extreme end of the ring portion 21, sufficient lifting force still cannot be applied without difficulty. Accordingly, in accordance with this invention, the ring portion 21 is provided with a transverse line of weakening in the form of a pair of transversely aligned notches 35. The notches 35 are disposed adjacent the cross bar 23 and extend through the outer wall 31 and the connecting walls 33 and 34, as is clearly shown in FIGURE 4. These notches 35 terminate in rounded ends 36, as is clearly shown in FIGURES 2 and 3, so as to eliminate stress points which would result in the tearing of the metal of the pull tab 10 through the bottom wall 32.

Due to the provision of the notches 35, it will be apparent from FIGURE 2 that a lifting force exerted on the remote end of the ring portion 21 will effect the ready bending of the ring portion 21 along the transverse line of the notches 35 to an upstanding position, as is shown by dotted lines in FIGURE 2. When the ring portion 21 reaches the elevated position shown in dotted lines in FIGURE 2, the metal of the outer wall 31 of the tubular bore part 30 comes into abutment and prevents further bending or hinging of the ring portion 21 relative to the remainder of the pull tab. When a further upwardly directed force is applied to the ring portion 21, it functions as a rigid element with the remainder of the pull tab and the desired leverage is obtained to effect the rupture of the end panel 12 along the score line 15, as is shown in FIGURE 3. It will thus be apparent that the simple formation of the notches 35 has an extremely desirable beneficial effect.

Reference is now made to FIGURE 6 wherein there is illustrated a blank 40 from which the pull tab 10 is formed. The blank 40 is formed flat from sheet metal and includes a generally horse shoe shaped body portion 41 which terminates at one end thereof in a pair of transversely aligned and spaced fulcrum defining ends 42. The horse shoe shaped body portion 41 is connected together adjacent the fulcrum defining ends 42, but spaced longitudinally therefrom, by a transverse cross bar 43 which is integral with the horse shoe shaped body 41. The cross bar 43 has a strap portion 44 projecting therefrom in spaced relation from the horse shoe shaped body 41. The connecting strap 44 has an aperture 45 formed therein and the combined shapes of the horse shoe shaped body 41 and the cross bar 43 define a large opening 46 with that portion of the blank 40 surrounding the opening 46 being generally considered a ring portion.

It is to be understood that the blank 40 is formed by a stamping or punching operation. At the time the blank 40 is being punched from a metal sheet, particularly when the aperture 45 is being formed, a pair of notches 47 are punched in the horse shoe shaped body 41 along a transverse line extending through the opening 46 and disposed adjacent the cross bar 43. These notches 47 have rounded ends 48.

From the foregoing description of the blank 40, it will be readily apparent that the notches 47, which become the notches 35 of the pull tab 10, are readily formed at no added expense except for the necessary tooling to form the punches. After the blank 40 has been formed, it is shaped in the conventional manner into the pull tab 10 without the notches 47 in any way affecting the shaping operation. Thus, the above-described beneficial notches

35 may be provided without any material additional costs or difficulties in fabrication.

Although only a preferred embodiment of the invention has been specifically illustrated and described herein, it is to be understood that minor variations may be made in the disclosed pull tab without departing from the spirit and scope of the invention, as defined by the appended claims.

I claim:

1. In a pull tab of the lever type which is secured to a container tear panel for effecting the removal thereof and wherein said pull tab is formed of sheet metal and is formed at one end with means for facilitating attachment to a container tear panel and at the other end with a ring portion to facilitate the lifting of said pull tab, the improvement residing in the provision of a transverse weakening line in said ring portion adjacent the connection of said ring portion with the remainder of said pull tab whereby when an initial lifting force is applied to said pull tab second end said ring portion will bend along said weakening line to an upstanding position whereat said ring portion may be fully engaged.

2. The pull tab of claim 1 wherein said pull tab has cooperating portions for limiting the bending of said ring portion to said upstanding position.

3. The pull tab of claim 1 wherein said ring portion is defined by a tubular border part of said pull tab, and said weakening line is in the form of a pair of transversely aligned notches in upper portions of said border part with the portions of said border part being engageable to limit the bending of said ring portion.

4. The pull tab of claim 1 wherein said ring portion is defined by a tubular border part of said pull tab, said tubular border including spaced upper and lower walls and intermediate connecting walls, and said weakening line being in the form of a pair of transversely aligned notches in said upper wall and said intermediate connecting walls of said border part with portions of said upper wall on opposite sides of said notch being engageable to limit the bending of said ring portion.

5. The pull tab of claim 4 wherein each notch has rounded end for eliminating stress points and preventing undesired tearing of said border part during continued lifting of said ring portion.

6. The pull tab of claim 4 wherein it is visually determinable that said notches were pre-formed by punching.

7. The pull tab of claim 4 wherein said notches are punched notches.

8. A blank for a pull tab comprising a sheet metal member having a generally horseshoe shaped outline terminating in two transversely spaced fulcrum defining ends, an integral transverse portion disposed adjacent said fulcrum defining ends and having a part thereof defining means for facilitating the connecting of the pull tab to another member, said sheet metal member having an opening therein immediately adjacent said transverse portion, and a pair of notches formed in said sheet metal member in transverse alignment along a line passing through said opening adjacent said transverse portion.

9. The blank of claim 8 wherein said notches have rounded ends.

10. In a pull tab of the lever type which is secured to a removable tear panel for effecting the removal thereof and wherein said pull tab is formed of sheet metal and is formed with a grip portion at one end and at least one securing means for facilitating attachment of said pull tab to said tear panel, the improvement residing in the provision of a transverse weakening generally in said grip portion and intermediate said one end and that securing means disposed adjacent to said grip portion for facilitating an initial bending of said pull tab when a light initial lifting force is applied thereto whereby said grip portion will tilt to a readily accessible position whereat said grip portion may be more posi-

5

tively gripped and a greater force applied to said pull tab.

11. A container of the easy opening type, said container having a removable panel portion of the tear-out type to facilitate the opening of said container, and a pull tab of the lever type secured to said removable panel portion for effecting the removal thereof, said pull tab being formed of sheet metal and having means at one end thereof facilitating attachment thereof to said removable panel portion and a ring portion at the other end thereof for facilitating the lifting of said pull tab, and said pull tab having a transverse weakening line in said ring portion adjacent the connection of said ring por-

6

tion with the remainder of said pull tab whereby when an initial lifting force is applied to said pull tab second end said ring portion will bend along said weakening line to an upstanding position whereat said ring portion may be fully engaged.

References Cited

UNITED STATES PATENTS

3,221,924	12/1965	Harvey et al.	220—54
3,349,949	10/1967	Brown et al.	220—54

GEORGE T. HALL, *Primary Examiner.*