

(19) World Intellectual Property
Organization
International Bureau



(43) International Publication Date
14 April 2005 (14.04.2005)

PCT

(10) International Publication Number
WO 2005/032425 A1

- (51) International Patent Classification⁷: **A61F 2/06**
- (21) International Application Number:
PCT/US2004/028426
- (22) International Filing Date:
1 September 2004 (01.09.2004)
- (25) Filing Language: English
- (26) Publication Language: English
- (30) Priority Data:
60/503,375 16 September 2003 (16.09.2003) US
10/930,523 31 August 2004 (31.08.2004) US
- (71) Applicant (for all designated States except US): **COOK INCORPORATED** [US/US]; 750 Daniels Way, Bloomington, IN 47404 (US).
- (72) Inventor: **DITTMAN, Jay, A.**; 421 W. 6th Street, Apartment B, Bloomington, IN 47404 (US).
- (74) Agent: **RICHARDSON, James, A.**; Brinks Hofer Gilson & Lione, Suite 1600, One Indiana Square, Indianapolis, IN 46204 (US).
- (81) Designated States (unless otherwise indicated, for every kind of national protection available): AE, AG, AL, AM, AT, AU, AZ, BA, BB, BG, BR, BW, BY, BZ, CA, CH, CN, CO, CR, CU, CZ, DE, DK, DM, DZ, EC, EE, EG, ES, FI, GB, GD, GE, GH, GM, HR, HU, ID, IL, IN, IS, JP, KE, KG, KP, KR, KZ, LC, LK, LR, LS, LT, LU, LV, MA, MD, MG, MK, MN, MW, MX, MZ, NA, NI, NO, NZ, OM, PG, PH, PL, PT, RO, RU, SC, SD, SE, SG, SK, SL, SY, TJ, TM, TN, TR, TT, TZ, UA, UG, US, UZ, VC, VN, YU, ZA, ZM, ZW.
- (84) Designated States (unless otherwise indicated, for every kind of regional protection available): ARIPO (BW, GH, GM, KE, LS, MW, MZ, NA, SD, SL, SZ, TZ, UG, ZM, ZW), Eurasian (AM, AZ, BY, KG, KZ, MD, RU, TJ, TM), European (AT, BE, BG, CH, CY, CZ, DE, DK, EE, ES, FI, FR, GB, GR, HU, IE, IT, LU, MC, NL, PL, PT, RO, SE, SI, SK, TR), OAPI (BF, BJ, CF, CG, CI, CM, GA, GN, GQ, GW, ML, MR, NE, SN, TD, TG).
- Published:**
— with international search report
- For two-letter codes and other abbreviations, refer to the "Guidance Notes on Codes and Abbreviations" appearing at the beginning of each regular issue of the PCT Gazette.

(54) Title: PROSTHESIS DEPLOYMENT SYSTEM

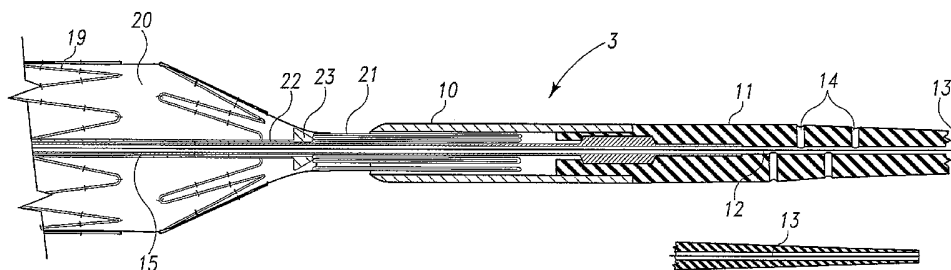

(57) Abstract: An introducer for an expandable endovascular prosthesis (20) having a self expanding stent (21) has a distal prosthesis positioning mechanism (2) and a proximal prosthesis retention mechanism (3). The proximal prosthesis retention mechanism (3) includes a cylindrical sleeve (10) adapted to retain the self expanding stent (21). A release mechanism (22,23) extends proximally from the distal prosthesis positioning mechanism (2) exerts a force in the proximal direction on the self expanding stent (21) to retain the self expanding (21) stent in the cylindrical sleeve (10).

WO 2005/032425 A1

PROSTHESIS DEPLOYMENT SYSTEM

BACKGROUND OF THE INVENTION

1. Technical Field.

[0001] This invention relates to a medical device and, in particular, a method and means for retaining and releasing an expandable, intraluminal prosthesis for the endovascular repair of diseased or damaged vessels.

[0002] Throughout this specification the terms proximal and proximally are used for a position or direction towards the patient's heart and the terms distal and distally are used for a position or direction away the patient's heart.

2. Related Art.

[0003] The deployment of intraluminal prostheses into the lumen of a patient from a remote location by the use of a deployment device or introducer has been disclosed in a number of earlier patents and patent applications. United States Patent No. 4,562,596 entitled "Aortic Graft, Device and Method for Performing an Intraluminal Abdominal Aortic Aneurysm Repair", which is herein incorporated by reference, proposes the retention of a self expanding graft within a sleeve until it is to be deployed, at which time the sleeve is withdrawn and the graft is allowed to expand. United States Patent No. 4,665,918 entitled "Prosthesis System and Method", which is herein incorporated by reference, proposes a system and method for the deployment of a prosthesis in a blood vessel. The prosthesis is positioned between a delivery catheter and an outer sheath and expands outwardly upon removal of the sheath.

[0004] United States Patent No. 4,950,227 entitled "Stent Delivery System", which is herein incorporated by reference, proposes the delivery of a stent by mounting the stent to the outside of an inflatable catheter and retaining the ends of an unexpanded stent by fitting a sleeve over either end of the stent. Expansion of the stent is caused by inflation of the catheter between the sleeves so that the ends of the stent are withdrawn from the respective sleeves and the stent released and expanded into position.

[0005] United States Patent No. 5,387,235 entitled “Endovascular Transluminal Prosthesis for Repair of Aneurysm”, discloses apparatus and methods of retaining grafts onto deployment devices. These features and other features disclosed in US Patent No. 5,387,235 could be used with the present invention, and the disclosure of US Patent No. 5,387,235 is herein incorporated by reference.

[0006] United States Patent No. 5,720,776 entitled “Expandable Transluminal Graft Prosthesis for Repair of Aneurysm” discloses improved barbs with various forms of mechanical attachment to a stent. These features and other features disclosed in US Patent No. 5,720,776 could be used with the present invention, and the disclosure of US Patent No. 5,720,776 is herein incorporated by reference.

[0007] United States Patent No. 6,206,931 entitled “Graft Prosthesis Materials” discloses graft prosthesis materials and a method for implanting, transplanting replacing and repairing a part of a patient and particularly the manufacture and use of a purified, collagen based matrix structure removed from a submucosa tissue source. These features and other features disclosed in US Patent No. 6,206,931 could be used with the present invention, and the disclosure of US Patent No. 6,206,931 is herein incorporated by reference.

[0008] PCT Patent Publication Number No. WO99/29262 entitled “Endoluminal Aortic Stents” discloses a fenestrated prosthesis for placement where there are intersecting arteries. This feature and other features disclosed in PCT Patent Publication Number No. WO99/29262 could be used with the present invention, and the disclosure of PCT Patent Publication Number No. WO99/29262 is herein incorporated by reference.

[0009] PCT Patent Publication Number No. WO03/034948 entitled “Prostheses for Curved Lumens” discloses prostheses with arrangements for bending the prosthesis for placement into curved lumens. This feature and other features disclosed in PCT Patent Publication Number No. WO03/034948 could be used with the present invention, and the disclosure of PCT Patent Publication Number No. WO03/034948 is herein incorporated by reference.

[0010] United States Published Patent Application No. 20030233140 entitled “Trigger Wire System” discloses release wire systems for the release of stent grafts

retained on introducer devices. This feature and other features disclosed in United States Published Patent Application No. 20030233140 could be used with the present invention, and the disclosure of United States Published Patent Application No. 20030233140 is herein incorporated by reference.

[0011] United States Published Patent Application No. 20040098079 entitled "Thoracic Aortic Stent Graft Deployment Device" discloses introducer devices adapted for deployment of stent grafts particularly in the thoracic arch. This feature and other features disclosed in United States Published Patent Application No. 20040098079 could be used with the present invention and the disclosure of United States Published Patent Application No. 20040098079 is herein incorporated by reference.

[0012] United States Published Patent Application No. 20040054396 entitled "Stent-Graft Fastening" discloses arrangements for fastening stents onto grafts particularly for exposed stents. This feature and other features disclosed in United States Published Patent Application No. 20040054396 could be used with the present invention, and the disclosure of United States Published Patent Application No. 20040054396 is herein incorporated by reference.

[0013] PCT Patent Publication Number No. WO03/053287 entitled "Stent Graft with Improved Graft Adhesion" discloses arrangements on stent grafts for enhancing the adhesion of such stent grafts into walls of vessels in which they are deployed. This feature and other features disclosed in PCT Patent Publication Number No. WO03/053287 could be used with the present invention, and the disclosure of PCT Patent Publication Number No. WO03/053287 is herein incorporated by reference.

[0014] PCT Patent Publication Number No. WO98/53761 entitled "A Prosthesis and a Method and Means of Deploying a Prosthesis", which is herein incorporated by reference, discloses various embodiments of an introducer for positioning an expandable endovascular prosthesis in a lumen of a patient. In one disclosed embodiment, the introducer includes a trigger wire mechanism to control the release of a proximal portion of the prosthesis. It would be desirable to provide a method and apparatus to deploy a graft prosthesis that provides a controlled release of a proximal portion of the prosthesis without the need for a trigger wire.

SUMMARY

[0015] An introducer for an expandable, endovascular prosthesis with a self expanding stent has proximal and distal prosthesis positioning mechanisms. The proximal prosthesis positioning mechanism has a cylindrical sleeve and a first control member to selectively disengage the cylindrical sleeve from the prosthesis. The distal prosthesis positioning mechanism has a distal retention section and a second control member to selectively disengage the distal retention section from the prosthesis. The first control member includes a first region coupled to the distal prosthesis positioning mechanism that extends longitudinally therefrom. The first control member also includes a second region that is coupled to the first region. The second region selectively and proximally disengages the self expanding stent to retain the self expanding stent in the cylindrical sleeve.

[0016] A method of placing a prosthesis into an internal lumen with an insertion assembly includes a step of inserting the insertion assembly including the prosthesis into the internal lumen and withdrawing a sheath from the insertion assembly to expose the prosthesis. A force is exerted on the prosthesis in a proximal direction by a release mechanism to retain the prosthesis in a prosthesis retention mechanism of the insertion assembly. The prosthesis retention mechanism is moved proximally away from the release mechanism to release the prosthesis from the insertion assembly. The sheath is replaced onto the insertion assembly, and the insertion assembly is retracted.

[0017] The invention can be better understood with reference to the following drawings and description. The components in the figures are not necessarily to scale, emphasis instead being placed upon illustrating the principles of the invention. Moreover, in the figures, like referenced numerals designate corresponding parts throughout the different views.

BRIEF DESCRIPTION OF THE DRAWINGS

[0018] FIG 1 is a perspective view of an introducer with a prosthesis partially deployed.

[0019] FIG 2 is a sectional detail view of a portion of the introducer around the distal end of the prosthesis.

[0020] FIG 3 is a sectional detail view of a portion of the introducer around the proximal end of the prosthesis.

[0021] FIG 4 is a sectional detail view of a portion of the introducer around the haemostatic seal.

[0022] FIG 5 is a sectional detail view of a portion of the introducer around the trigger wire release mechanism.

[0023] FIG 6 is a sectional detail view of the introducer around the pin vise clamp and the medical reagent introduction tube.

[0024] FIG 7 is a sectional view of the introducer of FIG 1 fully loaded and ready for introduction into a patient.

[0025] FIG 8 is a side elevation view, partially in section, of the introducer of FIG 7 in a first stage of deployment of the prosthesis.

[0026] FIG 9 is a side elevation view, partially in section, of the introducer of FIG 7 at the release of the proximal end stage of deployment.

[0027] FIG 10 is a side elevation view, partially in section, of the introducer of FIG 7 at the release of the distal end stage of deployment.

[0028] FIG 11 is a side elevation view, partially in section, of the introducer of FIG 7 showing an advancement of the distal attachment mechanism to the proximal attachment mechanism.

[0029] FIG 12 is a side elevation view, partially in section, of the introducer of FIG 7 showing the withdrawal of the introducer from within the expanded prosthesis.

DETAILED DESCRIPTION OF THE PREFERRED EMBODIMENTS

[0030] FIG 1 shows a prosthesis 20, and an endovascular deployment system, also known as an introducer, for deploying the prosthesis 20 in a lumen of a patient during a medical procedure. The introducer includes an external manipulation section 1, a distal positioning mechanism and attachment region 2, and a proximal positioning mechanism and attachment region 3. During a medical procedure to deploy the

prosthesis 20, the distal and proximal attachment regions 2 and 3 will travel through the lumen within a patient to a desired deployment site. The external manipulation section 1, which is acted upon by a user to manipulate the introducer, remains outside of the patient throughout the procedure.

[0031] The prosthesis 20 comprises a tubular graft material, such as Dacron, with self expanding stents 19 attached thereto. The self expanding stents 19 cause the prosthesis 20 to expand following disengagement from the introducer. The prosthesis 20 also includes a self expanding zigzag stent 21 that extends from the prosthesis proximal end. When disengaged from the introducer, the self expanding zigzag stent 21 anchors the proximal end of the prosthesis 20 to the lumen.

[0032] FIG 3 shows the proximal attachment region 3 in greater detail. The proximal attachment region 3 includes a cylindrical sleeve 10. The cylindrical sleeve 10 has a long tapered flexible extension 11 extending from the sleeve proximal end. The flexible extension 11 has an internal longitudinal aperture 12. The longitudinal aperture 12 facilitates advancement of the tapered flexible extension 11 along an insertion wire 13. The aperture 12 also provides a channel for the introduction of medical reagents. For example, it may be desirable to supply a contrast agent to allow angiography to be performed during placement and deployment phases of the medical procedure.

[0033] A thin walled tube 15, which can be made of metal, is fastened to the extension 11. The thin walled tube 15 is flexible so that the introducer can be advanced along a relatively tortuous vessel, such as a femoral artery. The flexibility of the thin walled tube 15 allows manipulation longitudinally and rotationally of the proximal attachment region 3. The thin walled tube 15 extends through the introducer to the manipulation section 1, terminating at a connection means 16, as shown in FIG 6.

[0034] Regarding the introduction of reagents, FIG 6 shows that the connection means 16 is adapted to accept a syringe to facilitate the introduction of reagents into the thin walled tube 15. The thin walled tube 15 is in fluid communication with the aperture 12 of the flexible extension 11. Therefore, reagents introduced into

connection means 16 can flow through the aperture 12 and emanate from the apertures 14.

[0035] As shown in FIG 2, a tube 41, which can be made of a suitable plastic, is coaxial and radially outside the thin walled tube 15. The tube 41 is "thick walled", that is to say the thickness of the wall of tube 41 is several times that of the thin walled tube 15. A sheath 30 is coaxial and radially outside the thick walled tube 41. The thick walled tube 41 and the sheath 30 extend distally to the manipulation region 1, as shown in FIG 4.

[0036] FIGS 2 and 3 illustrate retention, and distal and proximal release mechanisms of the introducer, respectively. During the placement phase of the medical procedure, the prosthesis 20 can be retained in a compressed condition by the sheath 30. The sheath 30 extends distally to a gripping and haemostatic sealing means 35 of the external manipulation section 1, shown in FIG 4.

[0037] During assembly of the introducer, the sheath 30 can be advanced over the cylindrical sleeve 10 of the proximal attachment region 3 while the prosthesis 20 is held in a compressed state by an external force. A distal attachment (retention) section 40 is formed in the thick walled tube 41 to retain the distal end of the prosthesis 20. Alternatively, the distal attachment section 40 can be a separate piece coupled to the thick walled tube 41.

[0038] A thin walled cannula 22 is also formed in the thick walled tube 41. Alternatively, the thin walled cannula 22 can be a separate piece coupled to the thick walled tube 41. The thin walled cannula 22 extends from the distal attachment section 40 to a conical tip 23. The conical tip 23 can be either coupled to the end of the thin walled cannula 22 or formed in the thick walled tube 41. The thick walled tube 41, the thin walled cannula 22, and the conical tip 23 are each coaxial with and radially outside the thin walled tube 15.

[0039] When the prosthesis 20 is in a compressed condition, the self expanding zigzag stent 21 is retained in the cylindrical sleeve 10 by the conical tip 23. The conical tip 23 asserts pressure on the distal end of the self expanding stent 21 in the proximal direction, holding the self expanding zigzag stent 21 in the cylindrical sleeve 10 without the need for a trigger wire. The self expanding stent 21 is

disengaged by first retracting the sheath 30, and then sliding the proximal attachment region 3, including the cylindrical sleeve 10, away from the conical tip 23. Once the cylindrical sleeve 10 has cleared the self expanding stent 21, the stent 21 will expand. The thin walled cannula 22 and the conical tip 23 form a control member to selectively disengage the cylindrical sleeve 10 from the prosthesis 20 by exerting force on (pushing) the self expanding stent 21 into the cylindrical sleeve 10 until the prosthesis 20 is positioned at a desired site in the lumen.

[0040] The distal end 42 of the prosthesis 20 is retained by the distal attachment section 40 of the thick walled tube 41. The distal end 42 of the prosthesis 20 has a loop 43 through which a distal trigger wire 44 extends. The distal trigger wire 44 extends through an aperture 45 in the distal attachment section 40 into the annular region between the thin walled tube 15 and the thick walled tube 41. As shown in FIG 5, the distal trigger wire 44 extends through the annular space between the thick walled tube 41 and the thin walled tube 15 to the manipulation region 1. The distal trigger wire 44 exits the annular space at a distal wire release mechanism 25. The distal trigger wire 44 and the distal wire release mechanism 25 form a control member to selectively disengage the distal retention section 40 from the prosthesis 20 when it is positioned at a desired site in a lumen of a patient.

[0041] FIG 4 shows the haemostatic sealing means 35 of the external manipulation section 1 shown in greater detail. The haemostatic sealing means 35 includes a haemostatic seal 27 a side tube 29. The haemostatic seal 27 includes a clamping collar 26 that clamps the sheath 30 to the haemostatic seal 27. The haemostatic seal 27 also includes a seal ring 28, which can be made of silicone. The seal ring 28 forms a haemostatic seal around the thick walled tube 41. The side tube 29 facilitates the introduction of medical reagents between the thick walled tube 41 and the sheath 30.

[0042] FIG 5 shows a proximal portion of the external manipulation section 1. The release wire actuation section has a body 36 that is mounted onto the thick walled tube 41. The thin walled tube 15 passes through the body 36. The distal wire release mechanism 25 is mounted for slidable movement on the body 36. A clamping screw 37 prevents inadvertent early disengagement of the distal end 42 of the prosthesis 20. A haemostatic seal 38 is provided so the trigger wire 44 can extend out

through the body 36 to the release mechanism 25 without unnecessary blood loss during the medical procedure.

[0043] FIG 6 shows a distal portion of the external manipulation section 1. A pin vise 39 is mounted onto the distal end of the body 36. The pin vise 39 has a screw cap 46. When screwed in, the vise jaws 47 clamp against and engage the thin walled tube 15. When the vise jaws 47 are engaged, the thin walled tube 15 can only move with the body 36, and hence the thin walled tube 15 can only move with the thick walled tube 41. With the screw cap 46 tightened, the entire assembly, except for the external sheath 30, can be moved as one.

[0044] FIGS 7 through 12 show the various stages of the deployment of the prosthesis 20 during the medical procedure. A guide wire 13 is introduced into a lumen such as the femoral artery and advanced until its tip is beyond the region into which the prosthesis 20 is to be deployed.

[0045] In FIG 7, the introducer assembly is shown fully assembled ready for introduction into a patient. The prosthesis 20 is retained at each of its ends by the proximal and distal retaining assemblies respectively, and compressed by the external sheath 30. If it is an aortic aneurism which is to be grafted, the introducer assembly can be inserted through a femoral artery over the guide wire 13 in the form as shown in FIG 7, and positioned by well-known radiographic techniques (not discussed here).

[0046] In FIG 8, the introducer assembly is in a desired position for deployment of the prosthesis 20. The external sheath 30 is withdrawn to just proximal of the distal attachment section 40. This action disengages the middle portion of the prosthesis 20 so that it can expand radially. The proximal self expanding stent 21, however, is still retained within the cylindrical sleeve 10. Also, the distal end 42 of the prosthesis 20 is still retained within the external sheath 30.

[0047] By release of the pin vise 39 to allow small movements of the thin walled tube 15 with respect to the thick walled tube 41, the prosthesis 20 can be lengthened or shortened or rotated or compressed for accurate placement in the desired location within the lumen. X-ray opaque markers (not shown) can be placed along the prosthesis 20 to assist with placement of the prosthesis.

[0048] In FIG 9, the screw cap 46 of the pin vise 39 has been loosened so that the thin walled tube 15 can be pushed in a proximal direction to move the proximal attachment sleeve 10 in a proximal direction. When the proximal attachment sleeve 10 no longer surrounds the self expanding stent 21 at the proximal end of the prosthesis 20, the self expanding stent 21 expands. When the stent 21 expands, the hooks or barbs 24 on the self expanding stent 21 grip into the walls of the lumen of the patient to hold the proximal end of the prosthesis 20 in place.

[0049] At this point, the distal end 42 of the prosthesis 20 is still retained by the distal attachment section 40, with the loop 43 retained therein. The external sheath 30 has been withdrawn to a position distal of the distal attachment section 40 to allow the distal end 42 of the prosthesis 20 to expand. At this point, the distal end 42 of the prosthesis 20 can still be moved. Consequently, the prosthesis 20 can still be rotated or lengthened or shortened or otherwise moved to for accurate positioning. Where the prosthesis 20 to be deployed is a bifurcated graft, the movement at this stage may ensure that the shorter leg is directed in the direction of the contra-iliac artery.

[0050] In FIG 10, the distal end 42 of the prosthesis 20 has been disengaged by removal of the distal trigger wire 44. At this stage, the distal trigger wire release mechanism 25 and the distal trigger wire 44 can be removed completely. This removal can be accomplished by passing the distal wire release mechanism 25 over the pin vise 39 and the connection means 16. The loop 43 of the terminal distal self expanding zigzag stent 19 is thus disengaged, and the prosthesis 20 is now free to expand to the walls of the vessel. At this point, the introducer is ready to be removed.

[0051] In FIG 11, the first stage of removal is shown. First, the distal attachment section 40 is advanced until the conical tip 23 is received in the rear of the proximal attachment sleeve 10. Next, the proximal attachment sleeve 10, the tapered flexible extension 11, and the distal attachment section 40, including the thin walled cannula 22 and the conical tip 23, are removed together, as shown in FIG 12.

[0052] In FIG 12, the sheath 30 has been advanced to cover the join between the proximal attachment sleeve 10 and the distal attachment section 40. The sheath 30 can be removed with the proximal attachment sleeve 10, the tapered flexible

extension 11 and the distal attachment section 40. Alternatively, these items could be removed separately, followed by removal of the external sheath 30.

[0053] Throughout this specification, unless the context requires otherwise, the words “comprise” and “include” and variations such as “comprising” and “including” will be understood to imply the inclusion of an item or group of items, but not the exclusion of any other item or group items.

[0054] While various embodiments of the invention have been described, it will be apparent to those of ordinary skill in the art that many more embodiments and implementations are possible within the scope of the invention. Furthermore, although various indications have been given as to the scope of this invention, the invention is not limited to any one of these but may reside in two or more of these combined together. Accordingly, the invention is not to be restricted except in light of the attached claims and their equivalents.

CLAIMS

1. An introducer for an expandable, endovascular prosthesis (20), the introducer comprising:

a distal prosthesis positioning mechanism (2) including a distal retention section (40) adapted to retain a distal portion (42) of an expandable endovascular prosthesis (20) and a first control member (25, 44) to selectively disengage the distal retention section (40) from the retained distal portion (42) of the prosthesis (20); and

a proximal prosthesis positioning mechanism (3) including a cylindrical sleeve (10) adapted to retain a proximal portion (21) of the prosthesis (20) and a second control member (22,23) to selectively disengage the cylindrical sleeve (10) from the proximal portion (21) of the prosthesis (20);

wherein the second control member includes a first region (22) coupled to the distal prosthesis positioning mechanism extending longitudinally therefrom, and a second region (23) coupled to the first region adapted to selectively and proximally engage a self expanding stent of said prosthesis to retain the self expanding stent in the cylindrical sleeve.

2. The introducer of claim 1, comprising a tube (41), wherein the first region (22) is coupled to and extends proximally from the tube.

3. The introducer of claim 1, comprising a tube (41), wherein the second region (23) is coupled to and extends proximally from the tube.

4. The introducer of any of claims 1-3, wherein the first region (22) is formed from the tube (41).

5. The introducer of any of claims 1-3, wherein the second region (23) is formed from the tube (41).

6. The introducer of claim 1, wherein the first region (22) includes a cannula.
7. The introducer of claim 6, comprising a tube (41), wherein the cannula is formed from the tube.
8. The introducer of claim 1, wherein the second region includes a conical tip (23).
9. The introducer of claim 8, comprising a tube (41), wherein the conical tip is formed from the tube.
10. The introducer of claim 1, comprising a tube (41), wherein the distal retention section (40) is coupled the tube (41).
11. The introducer of claim 1, comprising a tube (41), wherein the distal retention section (40) is formed from the tube (41).
12. The introducer of any of claims 1-3, 6-10 or 11, comprising a control arrangement (15, 41) for controlling the length of said prosthesis.
13. The introducer of any of claims 1-3, 6-10 or 11, comprising a rotational arrangement (15, 41) by which the relative angular orientation of the proximal and distal portions of said prosthesis can be adjusted.
14. The introducer of any of claims 1-3, 6-10 or 11, further comprising a control section (1) coupled to the proximal prosthesis positioning mechanism (3) and maintained external to the patient for selectively and proximally disengaging the second region (23) from the self expanding stent when the prosthesis (20) is positioned at a desired site in a lumen.
15. The introducer of claim 14, comprising a tube (41) coupled between the control section (1) and the first region (22) of the second control member.
16. The introducer of claim 14, comprising a tube (41) coupled between the control section (1) and the second region (23) of the second control member.

17. The introducer of claim 14, comprising a tube (41), wherein the first region (22) is formed from the tube (14).

18. The introducer of claim 14, comprising a tube (41), wherein the second region (23) is formed from the tube (14).

19. The introducer of claim 14, wherein the first region (22) comprises a cannula.

20. The introducer of claim 19, comprising a tube (41), wherein the cannula is formed from the tube.

21. The introducer of claim 14, wherein the second region (23) comprises a conical tip.

22. The introducer of claim 21, comprising a tube (41), wherein the conical tip is formed from the tube.

23. The introducer of claim 14, comprising a control arrangement (15, 41) for controlling the length of said prosthesis.

24. The introducer of claim 14, comprising a rotational arrangement (15, 41) by which the relative angular orientation of the proximal and distal portions of said prosthesis can be adjusted.

25. The introducer of claim 14, comprising a prosthesis positioning mechanism (2) coupled between the control section and the control member.

26. The introducer of claim 25, wherein the prosthesis positioning mechanism includes a distal attachment section (40), the control section comprises a tube (41), and the distal attachment section is coupled to the tube.

27. A method of placing a prosthesis into an internal lumen with an insertion assembly according to any of claims 1-3, 6-10 or 11, the method including the steps of:

- a. inserting the insertion assembly including the prosthesis into the internal lumen;
- b. withdrawing a sheath from the insertion assembly to expose the prosthesis;
- c. exerting force on the prosthesis in a proximal direction with a release mechanism to retain the prosthesis in a prosthesis retention mechanism of the insertion assembly;
- d. moving the prosthesis retention mechanism proximally away from the release mechanism to disengage the prosthesis from the insertion assembly;
- d. replacing the sheath onto the insertion assembly; and
- e. retracting the insertion assembly.

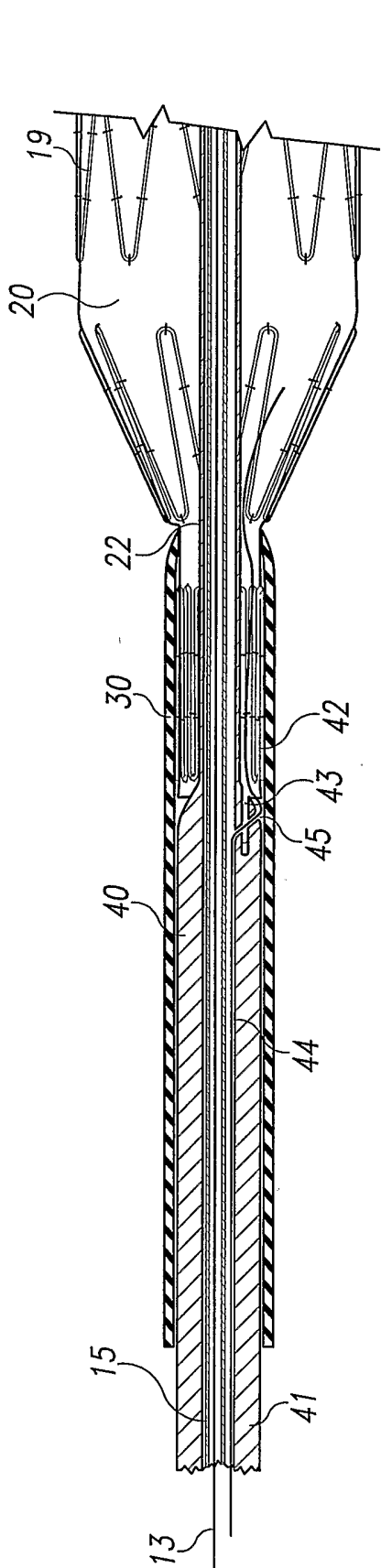

Fig. 2

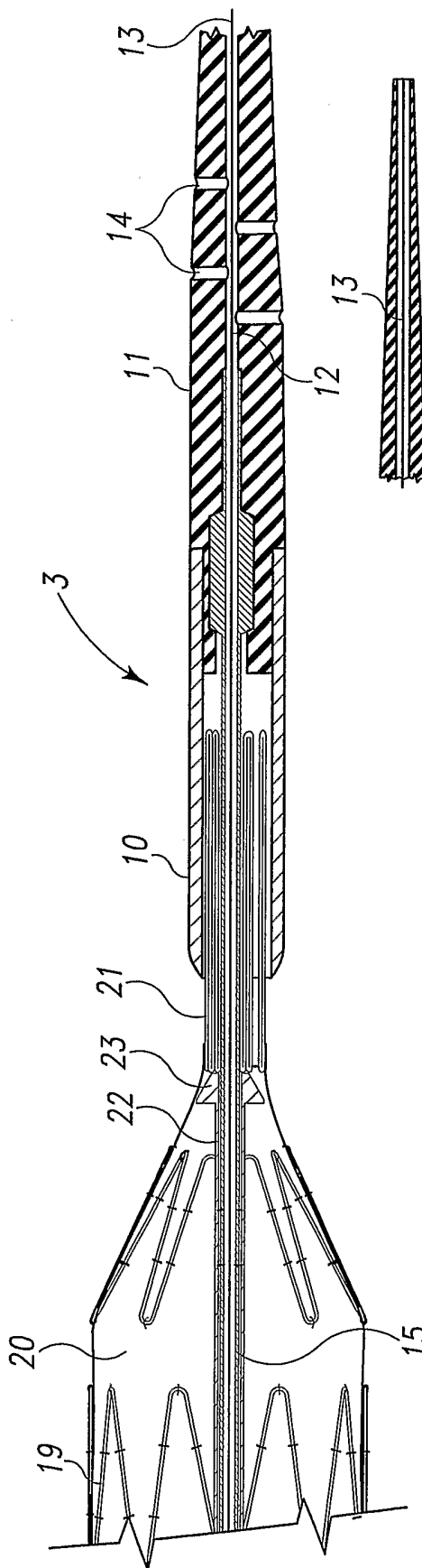

Fig. 3

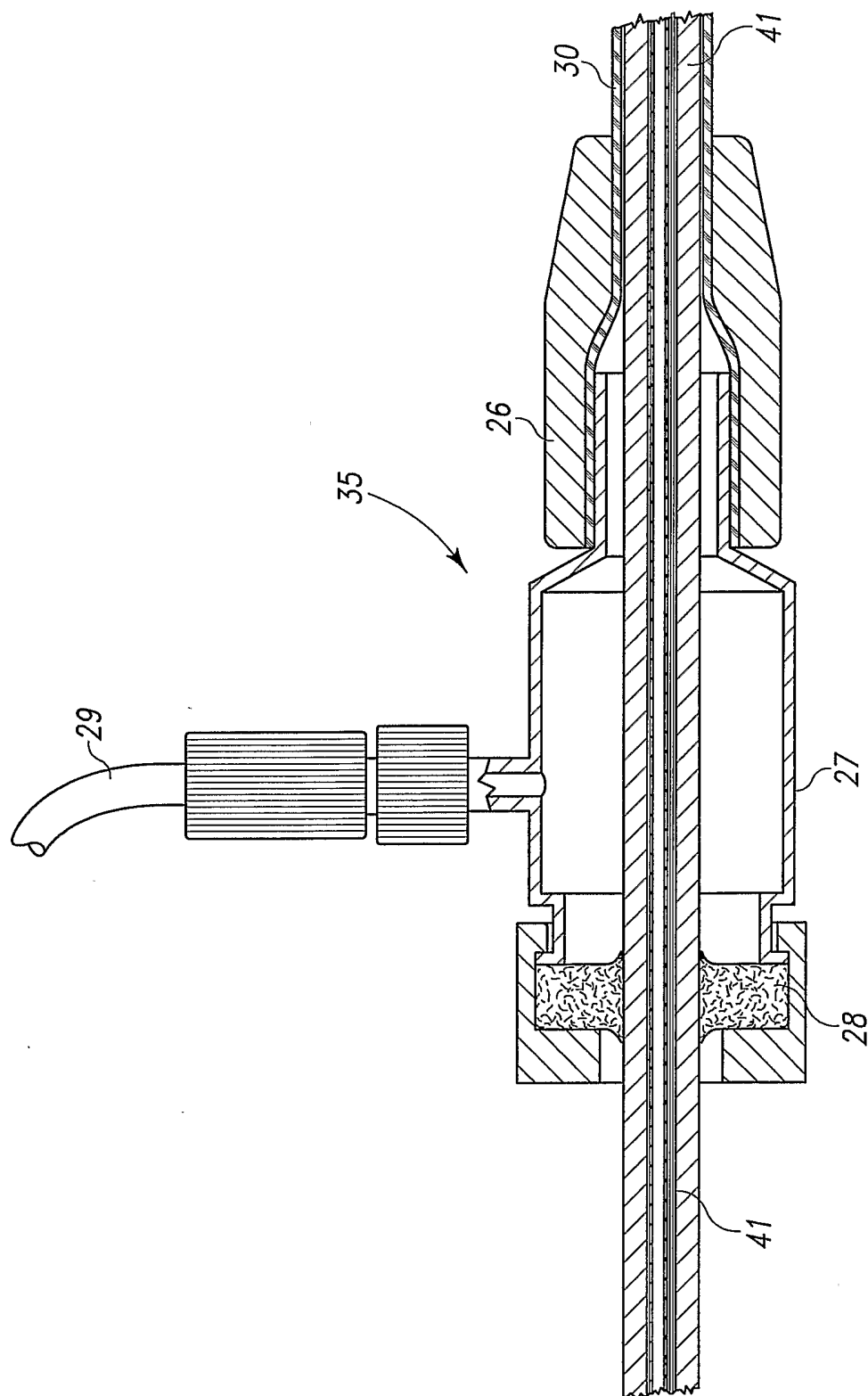

Fig. 4

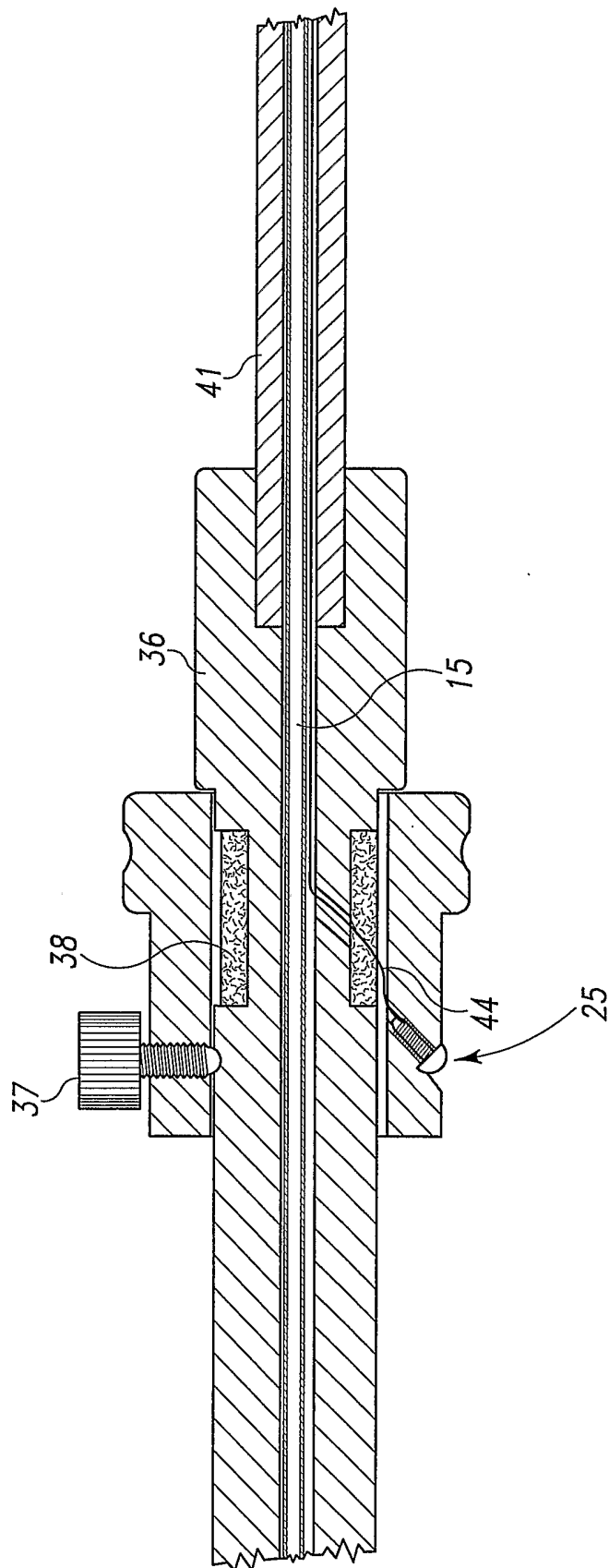

Fig. 5

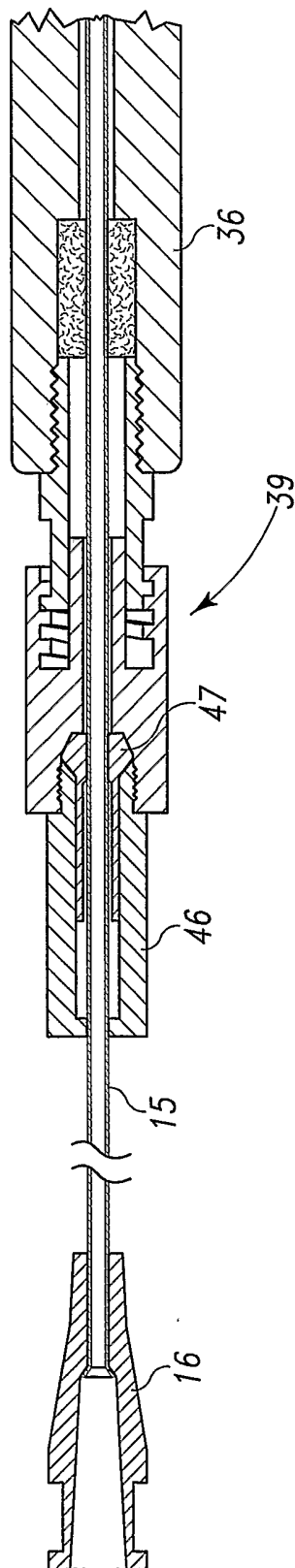

Fig. 6

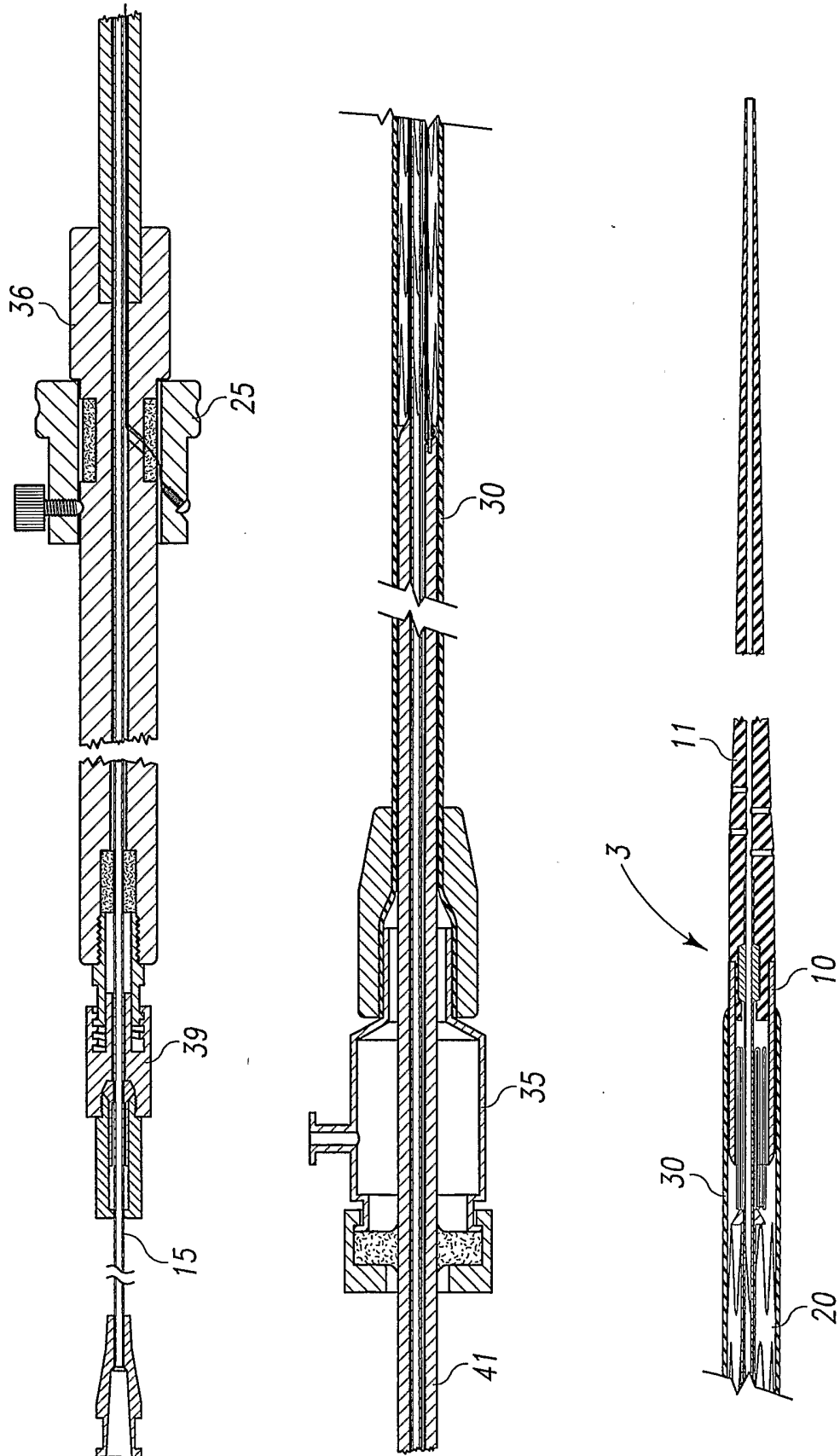

Fig. 7

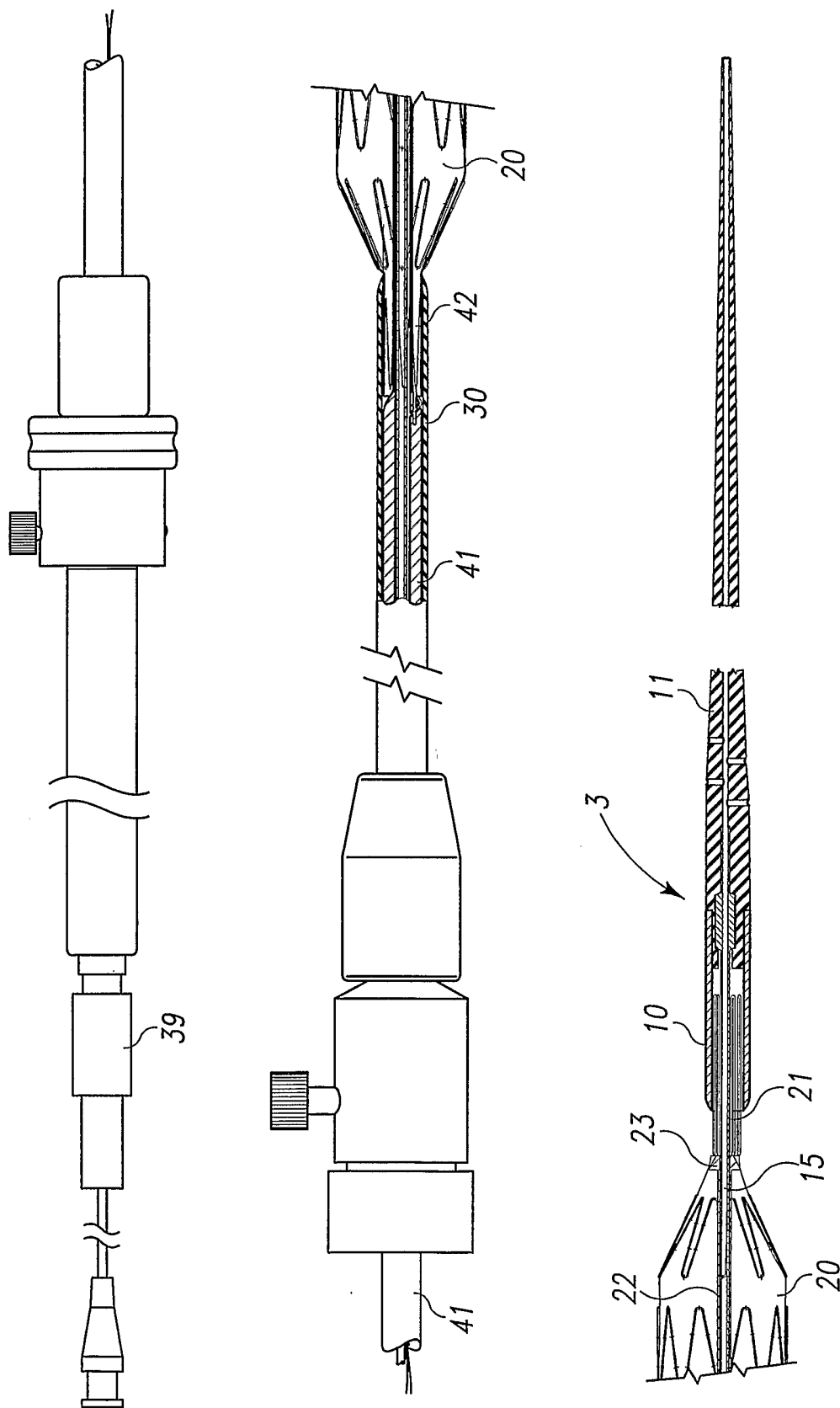

Fig. 8

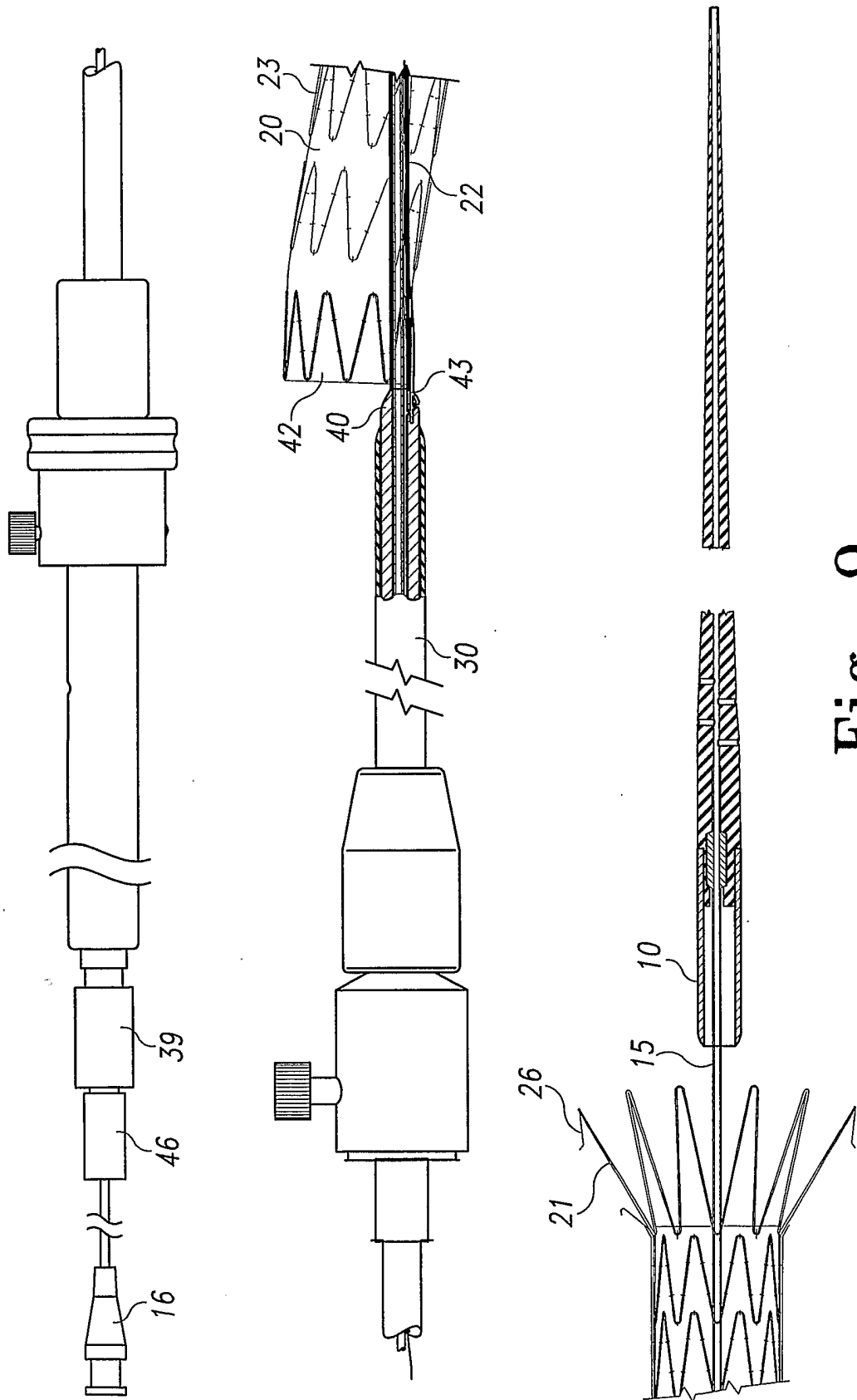

Fig. 9

9/11

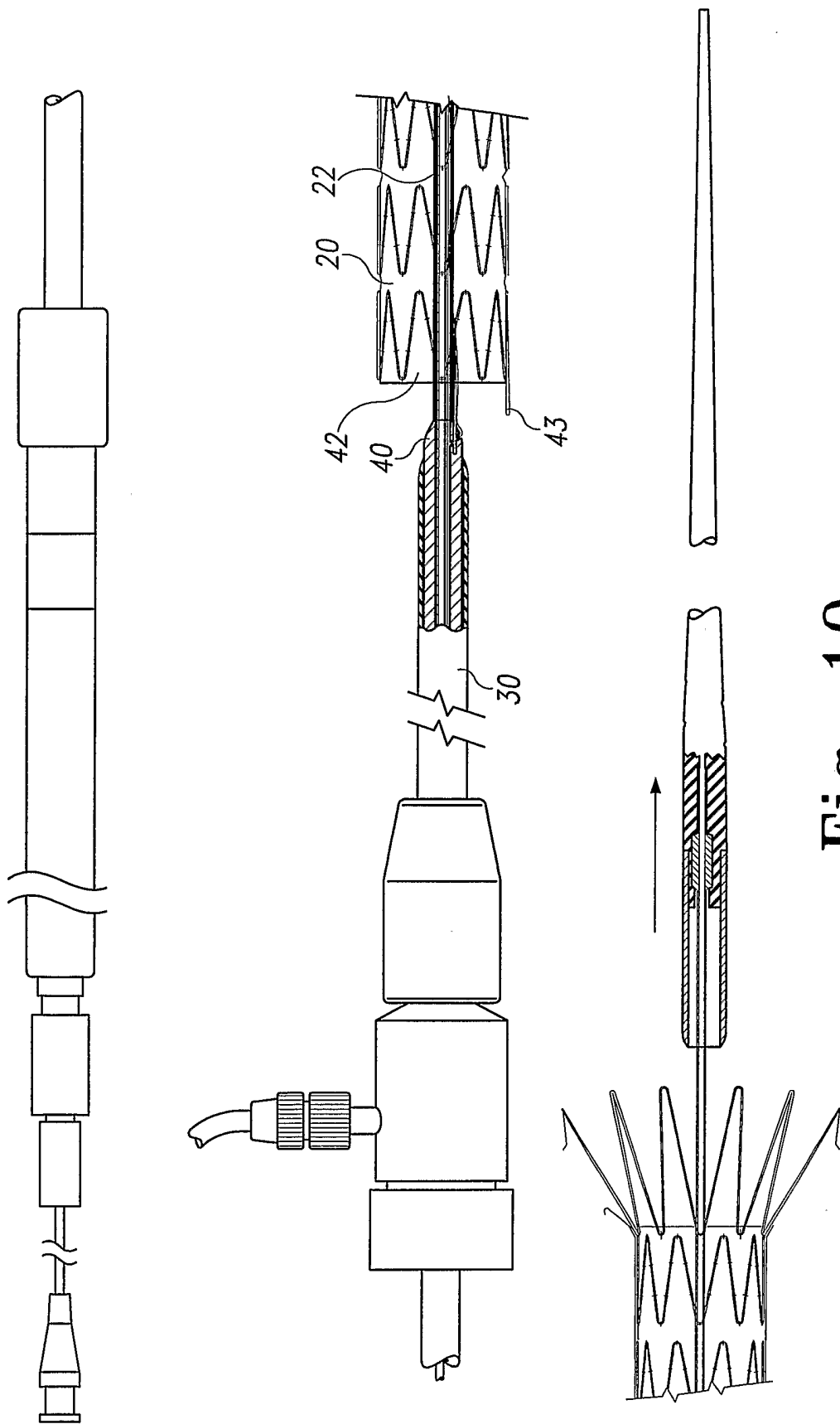

Fig. 10

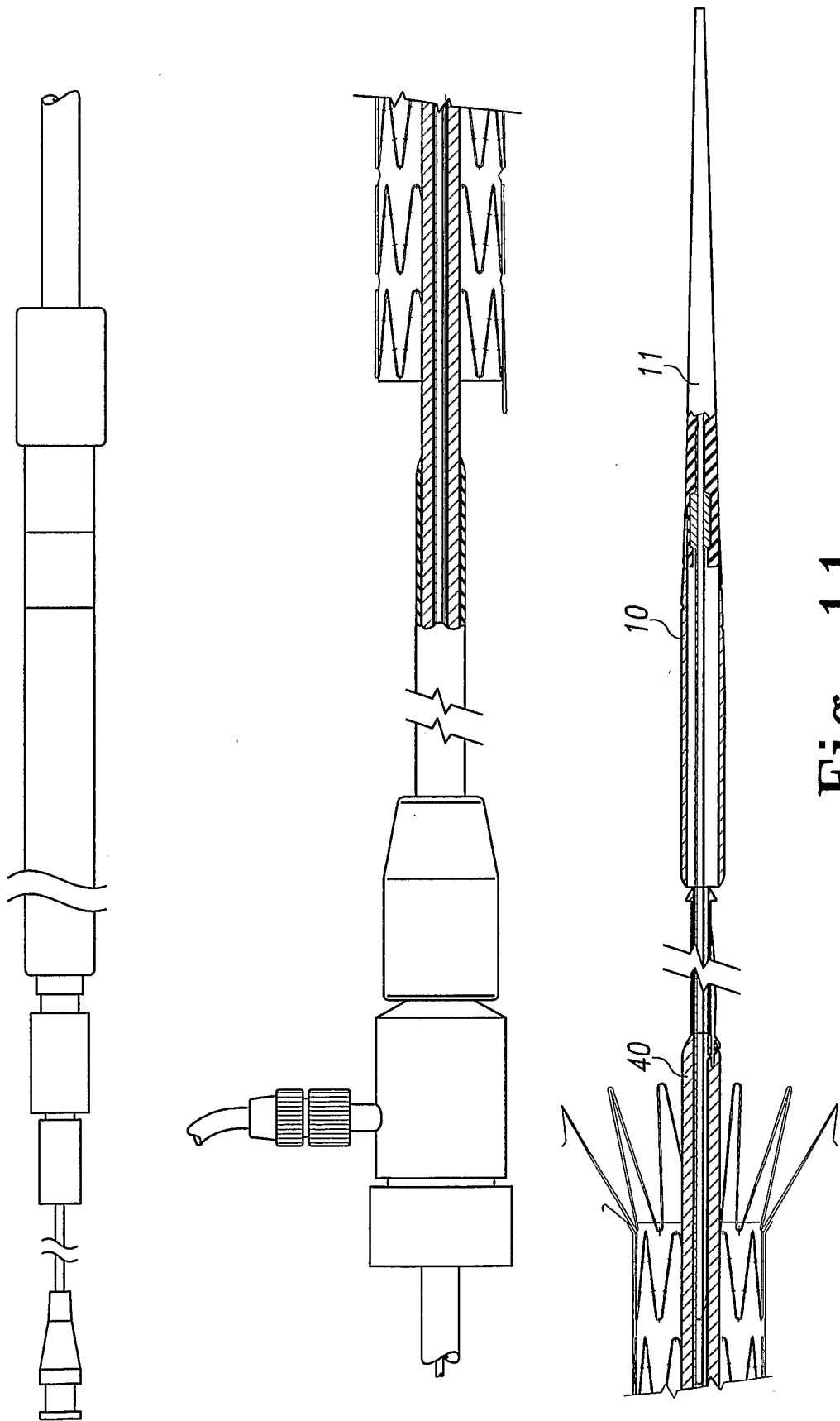

Fig. 11

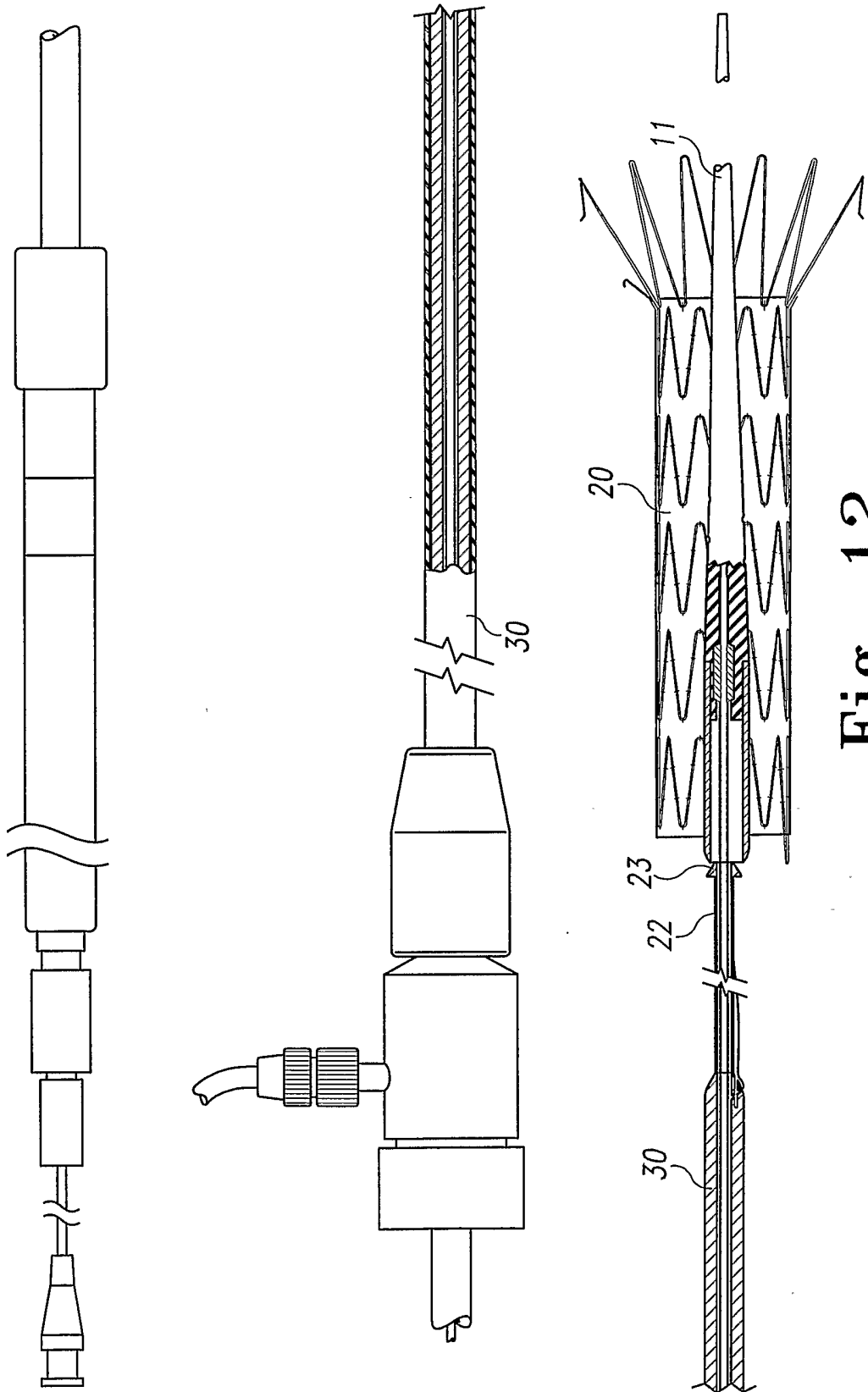

Fig. 12

INTERNATIONAL SEARCH REPORT

International Application No
PCT/US2004/028426A. CLASSIFICATION OF SUBJECT MATTER
IPC 7 A61F2/06

According to International Patent Classification (IPC) or to both national classification and IPC

B. FIELDS SEARCHED

Minimum documentation searched (classification system followed by classification symbols)
IPC 7 A61F

Documentation searched other than minimum documentation to the extent that such documents are included in the fields searched

Electronic data base consulted during the international search (name of data base and, where practical, search terms used)

EPO-Internal

C. DOCUMENTS CONSIDERED TO BE RELEVANT

Category °	Citation of document, with indication, where appropriate, of the relevant passages	Relevant to claim No.
A	WO 98/53761 A (HARTLEY DAVID ; COOK WILLIAM A AUSTRALIA (AU); LAWRENCE BROWN MICHAEL) 3 December 1998 (1998-12-03) the whole document	1-26
A	EP 0 684 022 A (ENDOVASCULAR TECH INC) 29 November 1995 (1995-11-29) column 10 - column 35; figures	1-26
A	US 2002/099432 A1 (YEE CARL E) 25 July 2002 (2002-07-25) the whole document	1-26

 Further documents are listed in the continuation of box C. Patent family members are listed in annex.

° Special categories of cited documents :

- *A* document defining the general state of the art which is not considered to be of particular relevance
- *E* earlier document but published on or after the international filing date
- *L* document which may throw doubts on priority claim(s) or which is cited to establish the publication date of another citation or other special reason (as specified)
- *O* document referring to an oral disclosure, use, exhibition or other means
- *P* document published prior to the international filing date but later than the priority date claimed

- *T* later document published after the international filing date or priority date and not in conflict with the application but cited to understand the principle or theory underlying the invention
- *X* document of particular relevance; the claimed invention cannot be considered novel or cannot be considered to involve an inventive step when the document is taken alone
- *Y* document of particular relevance; the claimed invention cannot be considered to involve an inventive step when the document is combined with one or more other such documents, such combination being obvious to a person skilled in the art.
- *&* document member of the same patent family

Date of the actual completion of the international search

17 January 2005

Date of mailing of the international search report

25/01/2005

Name and mailing address of the ISA

European Patent Office, P.B. 5818 Patentlaan 2
NL - 2280 HV Rijswijk
Tel. (+31-70) 340-2040, Tx. 31 651 epo nl,
Fax: (+31-70) 340-3016

Authorized officer

Serra i Verdaguer, J

INTERNATIONAL SEARCH REPORT

national application No.
PCT/US2004/028426

Box II Observations where certain claims were found unsearchable (Continuation of item 2 of first sheet)

This International Search Report has not been established in respect of certain claims under Article 17(2)(a) for the following reasons:

1. Claims Nos.: 27
because they relate to subject matter not required to be searched by this Authority, namely:
Rule 39.1(iv) PCT - Method for treatment of the human or animal body by surgery
2. Claims Nos.:
because they relate to parts of the International Application that do not comply with the prescribed requirements to such an extent that no meaningful International Search can be carried out, specifically:
3. Claims Nos.:
because they are dependent claims and are not drafted in accordance with the second and third sentences of Rule 6.4(a).

Box III Observations where unity of invention is lacking (Continuation of item 3 of first sheet)

This International Searching Authority found multiple inventions in this international application, as follows:

1. As all required additional search fees were timely paid by the applicant, this International Search Report covers all searchable claims.
2. As all searchable claims could be searched without effort justifying an additional fee, this Authority did not invite payment of any additional fee.
3. As only some of the required additional search fees were timely paid by the applicant, this International Search Report covers only those claims for which fees were paid, specifically claims Nos.:
4. No required additional search fees were timely paid by the applicant. Consequently, this International Search Report is restricted to the invention first mentioned in the claims; it is covered by claims Nos.:

Remark on Protest

- The additional search fees were accompanied by the applicant's protest.
- No protest accompanied the payment of additional search fees.

INTERNATIONAL SEARCH REPORT

International Application No
PCT/US2004/028426

Patent document cited in search report		Publication date	Patent family member(s)	Publication date
WO 9853761	A	03-12-1998	AU 736368 B2	26-07-2001
			AU 7513298 A	30-12-1998
			WO 9853761 A1	03-12-1998
			CA 2283782 A1	03-12-1998
			EP 1014888 A1	05-07-2000
			JP 2001526574 T	18-12-2001
EP 0684022	A	29-11-1995	US 5628783 A	13-05-1997
			AT 259625 T	15-03-2004
			AU 1644499 A	29-04-1999
			AU 698892 B2	12-11-1998
			AU 6219396 A	31-10-1996
			AU 669448 B2	06-06-1996
			AU 7143894 A	23-11-1995
			CA 2130138 A1	13-11-1995
			CA 2257663 A1	13-11-1995
			CA 2302116 A1	13-11-1995
			DE 69532567 D1	25-03-2004
			DE 69532567 T2	16-12-2004
			EP 0684022 A2	29-11-1995
			JP 8038486 A	13-02-1996
			US 6682557 B1	27-01-2004
			US 6322587 B1	27-11-2001
			US 6355061 B1	12-03-2002
			US 6235050 B1	22-05-2001
			US 5769885 A	23-06-1998
			US 5824044 A	20-10-1998
US 2004153143 A1	05-08-2004			
US 6663666 B1	16-12-2003			
US 6039758 A	21-03-2000			
US 2002099432	A1	25-07-2002	US 2002029076 A1	07-03-2002
			US 6398802 B1	04-06-2002
			US 2004049256 A1	11-03-2004
			AU 5319900 A	09-01-2001
			CA 2377338 A1	28-12-2000
			EP 1187577 A1	20-03-2002
			JP 2003502107 T	21-01-2003
			WO 0078248 A1	28-12-2000