

(19) **DANMARK**

(10) **DK/EP 2995234 T3**



(12) **Oversættelse af
europæisk patentskrift**

Patent- og
Varemærkestyrelsen

-
- (51) Int.Cl.: **A 47 L 9/02 (2006.01)**
- (45) Oversættelsen bekendtgjort den: **2017-04-24**
- (80) Dato for Den Europæiske Patentmyndigheds bekendtgørelse om meddelelse af patentet: **2017-01-25**
- (86) Europæisk ansøgning nr.: **15182633.6**
- (86) Europæisk indleveringsdag: **2015-08-27**
- (87) Den europæiske ansøgnings publiceringsdag: **2016-03-16**
- (30) Prioritet: **2014-08-28 IT MI20141519**
- (84) Designerede stater: **AL AT BE BG CH CY CZ DE DK EE ES FI FR GB GR HR HU IE IS IT LI LT LU LV MC MK MT NL NO PL PT RO RS SE SI SK SM TR**
- (73) Patenthaver: **New Ermes Europe S.r.l., Via Risorgimento, 19, 21020 Crosio della Valle (VA), Italien**
- (72) Opfinder: **Roschi, Riccardo, c/o NEW ERMES EUROPE S.r.l., Via Risorgimento, 19, 21020 Crosio della Valle (VA), Italien**
- (74) Fuldmægtig i Danmark: **PATRADE A/S, Fredens Torv 3A, 8000 Århus C, Danmark**
- (54) Benævnelse: **Sugedyse for en støvsuger eller lignende med støv-ophvirvlende anordning.**
- (56) Fremdragne publikationer:
DE-A1-102012 104 706
GB-A- 543 133
GB-A- 191 507 450
US-A- 2 626 419

DESCRIPTION

[0001] The present invention relates to a suction nozzle to be fitted to an electric household appliance for performing cleaning by means of suction, such as a vacuum cleaner, an electric broom or a multi-purpose drum vacuum cleaner or a robot vacuum cleaner, for sucking up dust and/or fluids and/or dirt from a surface. In particular, the present invention relates to a suction nozzle with a dust-raising device.

[0002] An example is given in US-A-2626419.

[0003] As is known, a vacuum cleaner, an electric broom or a similar electric household appliance for performing cleaning by means of suction comprises a suction nozzle for sucking up dust, dirt or fluids from a surface. In the sector of electric household appliances, a suction nozzle is generally referred to by the term "brush". For the purpose of the present description, therefore, the terms "suction nozzle" and "brush" are considered to be equivalent. Again for the purpose of the present invention, the term "vacuum cleaner" will be used with a broad meaning so as to include all those apparatus, for professional or domestic use, which perform cleaning by means of suction. Therefore, the term "vacuum cleaner" will comprise a vacuum cleaner, an electric broom, a so-called multi-purpose drum vacuum cleaner or a robot vacuum cleaner, a centralized suction system for domestic or industrial use and an apparatus for supplying and sucking in steam.

[0004] Basically a known suction nozzle comprises a base plate shaped so as to have at least one base plate channel open towards a surface to be vacuumed, a suction channel which, during use, is joined to the base plate and is in fluid communication with the base plate and optionally a covering body which can be connected to the base plate/suction channel assembly. The other end of the suction channel communicates with a suction tube usually via a rotatable joint. Also known are suction nozzles in which the suction channel, during use, is joined to the covering body.

[0005] In the present description and the claims the expression "width" of a suction nozzle, will be understood as meaning the maximum dimension (or footprint) of a suction nozzle without the covering body and calculated substantially parallel to a longitudinal axis of the base plate channel.

[0006] In the present description and the claims the expression "suction efficiency" will be understood as meaning essentially the ratio, in percentage terms, of the vacuumed material to the material to be vacuumed. The vacuuming tests are carried out in accordance with the provisions of the standard EN 60312-1:2013-05.

[0007] Although different suction nozzles which perform the function of sucking dust and/or fluids and/or dirt from a surface in a sufficiently efficient manner are available on the market, the Applicant has noticed that there exists the need to improve the performance of the known suction nozzles. In particular, the Applicant has noticed the need to increase the efficiency for suction of dust and dirt from surfaces which are not compact or are fibrous, such as carpets, rugs, mats, stair or hallway carpets or the like.

[0008] The Applicant has discovered that the suction efficiency on these surfaces is increased by suitably shaping the front and/or rear edge of the base plate channel so as to raise the material to be vacuumed when the suction nozzle is pushed forwards and/or pulled backwards.

[0009] According to an embodiment, the invention relates to a suction nozzle for a vacuum cleaner or the like, comprising a base plate with a base plate channel open towards the surface to be vacuumed, wherein said base plate channel comprises a first edge, a second edge, a first channel wall, a second channel wall and a channel bottom substantially opposite an opening formed between said first edge and said second edge, wherein said first channel wall comprises a first main wall and said second channel wall comprises a second main wall; wherein said first and second main walls are inclined so as to converge towards the bottom and wherein said first channel wall also comprises a first edge wall inclined so as to diverge from the second main wall towards the bottom.

[0010] The first edge wall forms a first tooth. The first main wall and the first edge wall form an obtuse angle greater than 90°.

[0011] The angle formed between the first main wall and the first edge wall is preferably between about 110° and about 165°, more preferably between 120° and 165°. In a preferred embodiment which has produced optimum results it is equal to about 150°-152°.

[0012] The first channel wall may be the front wall or the rear wall of the base plate channel.

[0013] According to an embodiment, said second channel wall also comprises a second edge wall inclined so as to diverge from the first main wall towards the bottom. The second edge wall forms a second tooth. The second main wall and the second edge wall form an obtuse angle greater than 90° and less than 180° .

[0014] The angle formed between the second main wall and the second edge wall is preferably between about 110° and about 165° , more preferably between 110° and 145° . In a preferred embodiment which has produced optimum results it is equal to about 130° - 132° .

[0015] The dust-raising device according to the invention comprises the first tooth and/or the second tooth. The main action of the (first and/or second) tooth is that of moving the fibers of the surface to be cleaned (carpets, rugs, mats, etc.). Therefore, by moving the fibers, the dust is detached more easily from the surface to be cleaned and is therefore more easily sucked up.

[0016] The first tooth is preferably provided substantially along the whole first edge. Alternatively it may be provided only along a central portion of the first edge or only along two end sections of said first edge or along the central portion of the first edge and along the end sections of the first edge or along a plurality of discrete sections of the first edge.

[0017] The second tooth is preferably provided substantially along the whole second edge. Alternatively it may be provided only along a central portion of the second edge or only along two end sections of the second edge or along the central portion of the second edge and along the end sections of the second edge or along a plurality of discrete sections of the second edge.

[0018] Preferably, the first tooth has a substantially triangular shape with a height of between about 1 mm and about 1.5 mm.

[0019] Preferably, the first tooth has a width of between about 0,5 mm and about 1 mm.

[0020] Preferably, the first edge surface forms an angle of about 40° - 65° with respect to a horizontal plane between said first edge and said second edge.

[0021] Preferably, the second tooth has a substantially triangular shape with a height of a between about 0,5 mm and about 1 mm.

[0022] Preferably, the second tooth has a width of between about 0.5 mm and about 1 mm.

[0023] Preferably, the second edge surface forms an angle of about 30° - 60° with respect to a horizontal plane between said first edge and said second edge.

[0024] Preferably, the base plate channel has a central portion offset with respect to the end sections.

[0025] The suction nozzle may have a front strip inclined at an angle of between 12° and 18° with respect to a plane in which the first edge and the second edge of the base plate channel lie.

[0026] Preferably, the suction nozzle comprises a rear strip having a width greater than the width of the front strip and wherein the rear strip has an inclined part and a flat part and wherein the inclined part is configured so that, during use, the suction nozzle may rotate upwards when pulled backwards and wherein the inclined part of the rear strip is inclined at an angle of between about 12° and about 18° with respect to the plane in which the first and second edges of the channel lie.

[0027] The present invention will become clearer from the following detailed description, provided by way of a non-limiting example, to be read with reference to the accompanying drawings, in which:

- Figure 1 shows a schematic cross-sectional view of a suction nozzle according to a first embodiment of the present invention;
- Figure 2 shows a schematic cross-sectional view of a suction nozzle according to a second embodiment of the present invention;
- Figure 3 shows a schematic cross-sectional view of a suction nozzle according to a third embodiment of the present invention;
- Figure 4 is a schematic plan view of a base plate of a suction nozzle according to an embodiment of the present invention;
- Figure 5.1 is a cross-sectional view, on a larger scale, of the base plate channel of the embodiment shown in Figure 1;

- Figure 5.2 is a cross-sectional view, on a larger scale, of the base plate channel of the embodiment shown in Figure 2; and
- Figure 5.3 is a cross-sectional view, on a larger scale, of the base plate channel of the embodiment shown in Figure 3.

[0028] In the various figures, for the sake of clarity, some components not considered essential for the present invention have been omitted. In particular, the pedal and the associated control mechanism for moving a bristled support or a rubber fin which could be present in some embodiments are not shown. The suction nozzle is denoted overall by the reference number 1.

[0029] With reference to the various figures, the suction nozzle 1 comprises a base plate 2 with at least one base plate channel 3 open downwards, namely towards a surface to be vacuumed. Preferably it comprises also a curved and suitably shaped suction channel 4 and a rotatable joint 5 rotating about an axis 6. The assembly consisting of the channel 3, the channel 4 and the joint 5 forms the suction duct 7.

[0030] The base plate 2 and the base plate channel 3 are described in greater detail hereinbelow.

[0031] The base plate 2 (Figure 4) has preferably a more or less rectangular shape with rounded corner edges. It has a greater dimension (length) L2 and a smaller dimension (width) W2. The base plate channel 3 extends substantially (at least partly) parallel to the length L2 of the base plate 2.

[0032] The base plate channel 3 extends substantially over the entire length L2 of the base plate, from one end to the other. The base plate channel 3 may be substantially straight or, as shown in Figure 4, have a central portion offset with respect to the end sections. The present invention is not limited to either embodiment.

[0033] The shape of the base plate channel 3, in plan view, has preferably a front edge 31 which is substantially straight and parallel to the front edge 21 of the base plate 2 or is formed with straight sections joined by curved sections.

[0034] The rear edge 32 of the base plate channel 3 is preferably parallel to the rear edge 22, of the base plate along its whole length L2 except for optionally the ends 33 which are preferably inclined towards the front edge 31 such that the width of the base plate channel 3 is gradually reduced.

[0035] Preferably, the minimum width of the base plate channel is between 40% and 60% of its maximum width. The maximum width of the base plate channel 3 is 5-7% of the length L2 of the base plate channel 3.

[0036] In a preferred embodiment, the minimum width is substantially 50% of the maximum width. For example, for a base plate with L2=253 mm and a base plate channel 3 with a width of about 16.4 mm, the minimum width of the base plate channel at the ends 33 is about 8.22 mm.

[0037] Each of the two end sections 33 of base plate channel 3 with decreasing width has a length L33 (measured parallel to the front edge 21) of between 9% and 13% of the length of the base plate channel. Preferably it is equal to about 11.7%. In the embodiment in which the length L2 of the base plate is equal to 253 mm, each of the sections L33 measures about 29 mm.

[0038] The front strip 34 between the front edge 21 of the base plate and the front edge 31 of the channel 3 has a smaller width and is inclined so that, during use, the suction nozzle 1 may rotate downwards when pushed forwards.

[0039] Preferably, the front strip 34 is inclined at an angle of between 12° and 18° with respect to a horizontal plane H defined by the front edge 31 and rear edge 32 of the base plate channel 3. Preferably, in a central position, a band 35 of velvet or similar material is provided in order to trap between its fibers dust and other micro particles. It may be glued to the front strip 34 and optionally inset in a cavity not shown.

[0040] The rear strip 36 between the rear edge 22 of the base plate and the rear edge 32 of the base plate channel 3 has a width greater than the width of the front strip 34. In one embodiment, the rear strip 36 has an inclined part and a flat part. The inclined part is configured so that, during use, the suction nozzle 1 may rotate upwards when pulled backwards.

[0041] Preferably, the inclined part of the rear strip 36 is inclined at an angle of between about 12° and about 18° with respect to the plane H. Preferably, in a central position a band 35 of velvet or similar material is provided in order to trap between its fibers dust and other micro particles. It may be glued to the rear strip 36 and optionally inset in a cavity not shown.

[0042] The base plate channel 3 is open towards the surface to be vacuumed. The channel 3 is formed by the front edge 31, the rear edge 32, a front wall, a rear wall and the bottom 331. The bottom 331 is substantially opposite the opening formed between the front edge 31 and the rear edge. During use, the front and rear edges rest on the surface to be vacuumed.

[0043] In the present description and in the claims, the term "front" may be replaced by the term "first" or "second". Similarly, the term "rear" may be replaced by the term "second" or "first".

[0044] The front wall comprises a main front wall 311 and, similarly, the rear wall comprises a main rear wall 321. Each of the two main (front and rear) walls extends from the bottom of the channel 3 towards the respective (front and rear) edges. If an edge surface (which will be described below) is present, the main wall terminates where the edge wall starts. If an edge surface is not present, the main wall is flat, without discontinuities and terminates at the edge.

[0045] The main front wall 311 and the main rear wall 321 are inclined so as to converge towards the bottom 331, as clearly shown in Figures 5.1, 5.2 and 5.3.

[0046] According to a first embodiment of the present invention, along at least a part of the front wall, a front edge wall 312 inclined so as to diverge from the rear end wall 321 towards the bottom 331 is provided. The front edge wall forms a front tooth 8 (Figure 1 and Figure 5.1) configured to engage with the surface to be cleaned so as to favor the raising of dust or other particles from the fibrous support of the surface to be cleaned. The front tooth 8 may be provided along the whole front edge 31 (both on the straight sections and on the curved sections). Alternatively, the front tooth 8 may be provided along a part thereof (for example along the central portion and/or along the side sections). Alternatively, less preferably, the front tooth 8 may be formed by segments separated by toothless sections so as to form a comb-like configuration.

[0047] The front tooth 8 favors separation of the dust from the fibrous support of the surface to be cleaned, especially when the suction nozzle 1 is pulled backwards.

[0048] As shown in the larger-scale view of Figure 5.1, the front tooth 8 has a substantially triangular shape projecting downwards and towards the inside of the channel 3 of the base plate 2.

[0049] In one embodiment, the front tooth 8 has a height 81 of between about 1 mm and about 1.5 mm. Preferably it has a height 81 of about 1.4 - 1.5 mm. The height 81 is measured with respect to the plane of the front strip 34.

[0050] In one embodiment, the front tooth 8 has a width 82 of between about 0.5 mm and about 1 mm. Preferably it has a width 82 of about 0.7 - 0.8 mm. The width 82 is measured in a direction perpendicular to the front surface 311 of the channel 3.

[0051] Therefore, the front edge wall 312 extends inside the base plate channel 3 from the front edge 31 and has an extension which may be easily calculated based on the height measurement 81 and width measurement 82. The front main wall 311 and the front edge wall 312 form an obtuse angle, namely an angle greater than 90°.

[0052] The angle formed between the front main wall 311 and the front edge wall 312 is preferably between about 110° and about 165°, more preferably between 120° and 165°. In a preferred embodiment which has produced optimum results it is equal to about 150°-152°.

[0053] In one embodiment, the front tooth 8 forms an angle 83 with the horizontal plane H which joins together the front edge 31 and the rear edge 32, equal to about 60° - 80°. Preferably it is equal to about 65°-75°. More preferably it is equal to about 70°.

[0054] In one embodiment, the front tooth 8 forms an angle 84 with the front strip 34 equal to about 40°-60°. Preferably it is equal to about 50°-55°. In a preferred embodiment, the angle 84 is equal to about 52°.

[0055] Preferably the tip of the front tooth 8 is substantially in the form of a sharp edge.

[0056] According to a second embodiment of the present invention, along at least a part of the rear wall, a rear edge wall 322 inclined so as to diverge from the front main wall 311 towards the bottom 331 is provided. The rear edge wall forms a rear tooth 9 (Figure 2 and Figure 5.2) configured to engage with the surface to be cleaned so as to favor the raising of dust or other particles from the fibrous support of the surface to be cleaned. The rear tooth 9 may be provided along the whole rear edge 32 (both on the straight sections and on the curved sections). Alternatively, the rear tooth 9 may be provided along a part thereof (for example along the central portion and/or along the side sections). Alternatively, less preferably, the rear tooth 9 may be formed by segments separated by toothless sections so as to form a comb-like configuration.

[0057] The rear tooth 9 favors separation of the dust from the fibrous support of the surface to be cleaned, especially when the suction nozzle 1 is pushed forwards.

[0058] As shown in the larger-scale view of Figure 5.2, the rear tooth 9 has a substantially triangular shape projecting downwards and towards the inside of the channel 3 of the base plate 2.

[0059] In one embodiment, the rear tooth 9 has a height 91 of between about 0.5 mm and about 1 mm. Preferably it has a height 91 of about 0.5 - 0.8 mm. More preferably it has a height 91 of about 0.7 mm. The height 91 is measured with respect to the plane of the rear strip 36.

[0060] The height 91 of the rear tooth is preferably less than the height 81 of the front tooth 81.

[0061] In one embodiment, the rear tooth 9 has a width 92 of between about 0.5 mm and about 1 mm. Preferably it has a width 92 of about 0.7 - 0.8 mm. The width 92 is measured in a direction perpendicular to the rear surface 321 of the channel 3.

[0062] Therefore, the rear edge wall 322 extends inside the base plate channel 3 from the rear edge 32 and has an extension which can be easily calculated based on the height measurement 91 and width measurement 92. The rear main wall 321 and the rear edge wall 322 form an obtuse angle, namely an angle greater than 90°.

[0063] The angle formed between the rear main wall 321 and the rear edge wall 322 is preferably between about 110° and about 165°, more preferably between 110° and 145°. In a preferred embodiment which has produced optimum results it is equal to about 130°-132°.

[0064] In one embodiment, the rear tooth 9 forms an angle 93 with the horizontal plane H which joins together the front edge 31 and the rear edge 32, equal to about 30° - 60°. Preferably it is equal to about 40°-60°. In a preferred embodiment, the angle 93 is equal to about 45°.

[0065] Preferably the tip of the rear tooth 9 is substantially in the form of a sharp edge.

[0066] Figures 3 and 5.3 show a third embodiment of the present invention. The third embodiment is substantially a combination of the first embodiment with front tooth 8 and the second embodiment with rear tooth 9. All the comments made for the first and second embodiments are applicable to the third embodiment and will not be repeated.

[0067] The dimensions and the inclination of the front edge wall 312 may remain unchanged along the whole front edge 31 or may vary. In the same way, the dimensions and the inclination of the rear edge wall 322 may remain unchanged along the whole rear edge 32 or may vary.

[0068] During use, the front edge wall 312 and/or the rear edge wall 322 rub against the surface to be cleaned, which may be a non-compact or fibrous surface, such as a carpet, rug, mat, stair or hallway carpet or the like. The friction favors raising of dust (or other trapped particles) which are therefore more effectively vacuumed. In addition to raising dust, the teeth bend the fibers and open up interstices which, once again, facilitate suction of the particles.

[0069] In addition to the friction effect, the (front and/or rear) edge wall reduces slightly the width of the opening of the base channel and thus improves the suction performance compared to a base plate channel without teeth.

REFERENCES CITED IN THE DESCRIPTION

This list of references cited by the applicant is for the reader's convenience only. It does not form part of the European patent document. Even though great care has been taken in compiling the references, errors or omissions cannot be excluded and the EPO disclaims all liability in this regard.

Patent documents cited in the description

- US2626419A [0002]

PATENTKRAV

- 5 1. Sugedyse (1) for en støvsuger eller lignende, omfattende en basisplade (2) med en basispladekanal (3), som er åben mod en overflade, der skal ren-suges,
- 10 - hvorved basispladekanal (3) omfatter en første kant (31; 32), en anden kant (32; 31), en første kanalvæg, en anden kanalvæg og en kanalbund (331) i det væsentlige beliggende over for en åbning, som er dannet mellem den første kant (31; 32) og den anden kant (32; 31),
- 15 - hvorved den første kanalvæg omfatter en første hovedvæg (311; 321), og den anden kanalvæg omfatter en anden hovedvæg (321; 311);
- 20 - hvorved den første og den anden hovedvæg (311; 321) er anbragt med en hældning, så de konvergerer mod bunden (331), og
- hvorved den første kanalvæg (311; 321) også omfatter en første kantvæg (312; 322) med en sådan hældning, at den divergerer fra den anden hovedvæg (321; 311) hen imod bunden (331), således at en vinkel, der er større end 90° og mindre end 180° , dannes mellem den første kantvæg (312; 322) og den første hovedvæg (311; 321).
- 25 2. Sugedyse ifølge krav 1, hvorved den anden kanalvæg (321; 311) også omfatter en anden kantvæg (322; 312), der har en sådan hældning, at den divergerer fra den første hovedvæg (311; 321) hen imod bunden (331), således at en vinkel, der er større end 90° og mindre end 180° , dannes mellem den anden kantvæg (322; 312) og den anden hovedvæg (321; 311).
- 30 3. Sugedyse (1) ifølge krav 1 eller krav 2, hvorved den første kantvæg (312; 322) er tilvejebragt i det væsentlige langs hele den første kant (31; 32).
- 35 4. Sugedyse (1) ifølge krav 1, 2 eller 3, hvorved den anden kantvæg (322; 312) er tilvejebragt i det væsentlige langs hele den anden kant (32; 31).

5. Sugedyse (1) ifølge et hvilket som helst af de foregående krav, hvorved den første kantvæg (312; 322) er skråtstillet i en vinkel (83) på cirka 60° - 80° i forhold til et plan (H), som ligger mellem den første kant (31) og den anden kant (32).
- 5
6. Sugedyse (1) ifølge et hvilket som helst af de foregående krav, hvorved den anden kantvæg (322; 312) er skråtstillet i en vinkel (93) på cirka 30° - 60° i forhold til et plan (H), i hvilken den første kant (31) og den anden kant (32) ligger.
- 10
7. Sugedyse (1) ifølge et hvilket som helst af de foregående krav, hvorved basispladekanalen (3) i det væsentlige er retlinjet eller har et midterområde, som er forskudt i forhold til ende-områderne.
- 15
8. Sugedyse (1) ifølge et hvilket som helst af de foregående krav, hvorved en frontstrimmel (34) er skråtstillet i en vinkel på mellem 12° og 18° i forhold til et plan, i hvilket den første kant og den anden kant af basispladens kanal (3) ligger.
- 20
9. Sugedyse (1) ifølge krav 8, hvorved en bageste strimmel (36) har en bredde, der er større end bredden af frontstrimlen (34), og hvorved den bageste strimmel (36) har en skråtstillet del og en flad del, og hvorved den skråtstillede del er konfigureret således, at sugedysen (1) under anvendelsen kan dreje opad, når sugedysen trækkes bagud, og hvorved den skråtstillede del af bagstrimlen (36) er skråtstillet en vinkel mellem cirka 12° og cirka 18° i forhold til et plan, i hvilket den første og den anden kant af basispladekanalen (3) ligger.
- 25

DRAWINGS

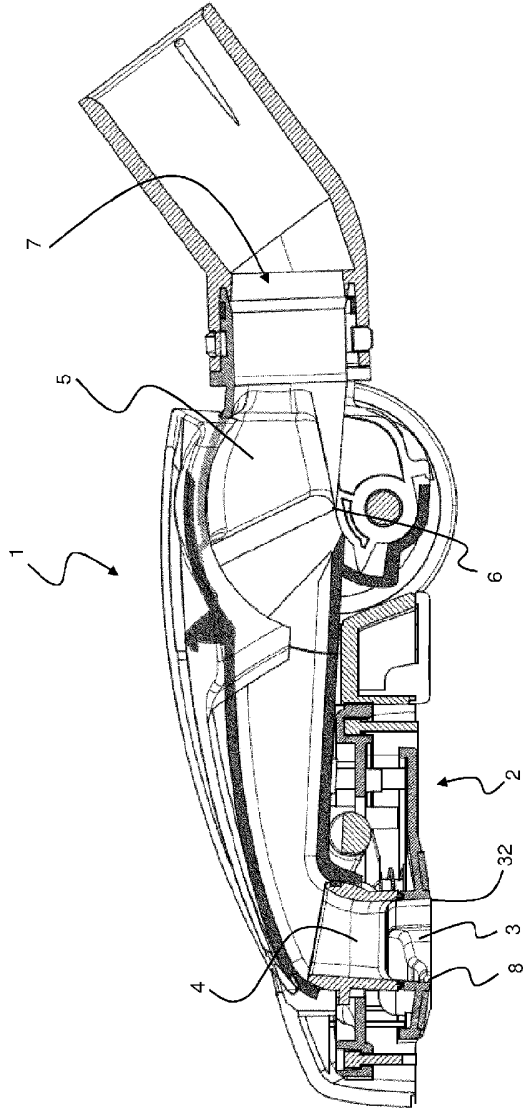

Fig. 1

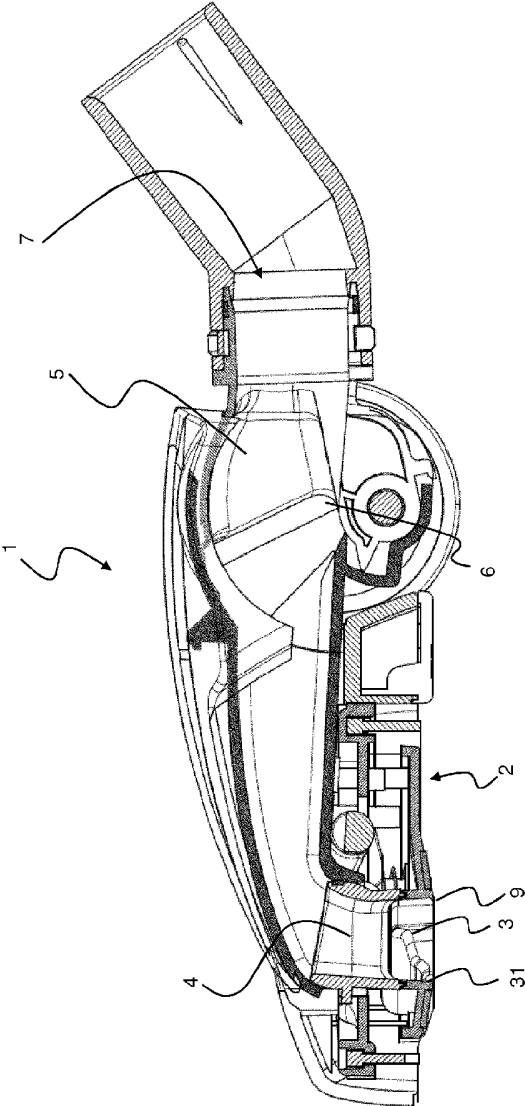

Fig. 2

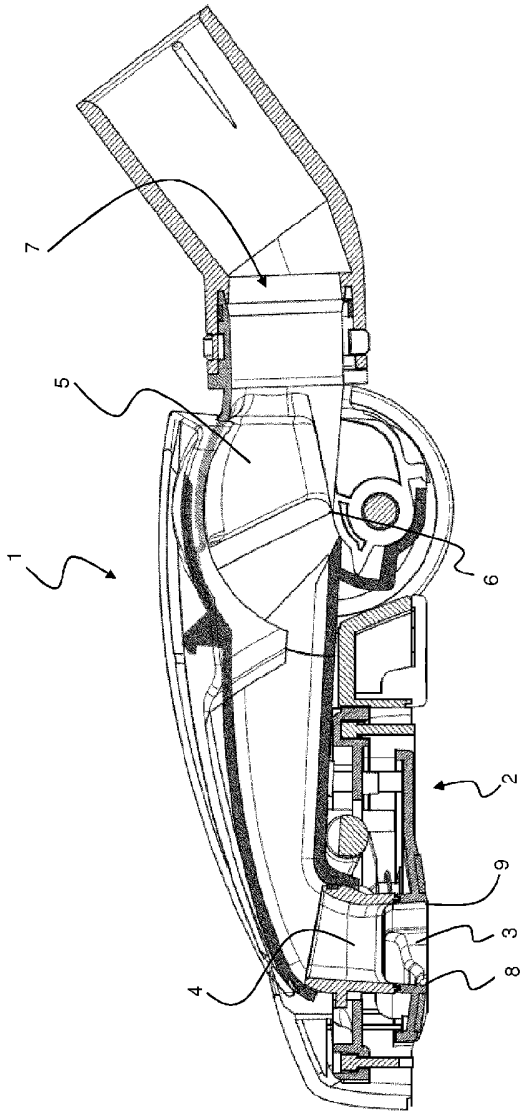

Fig. 3

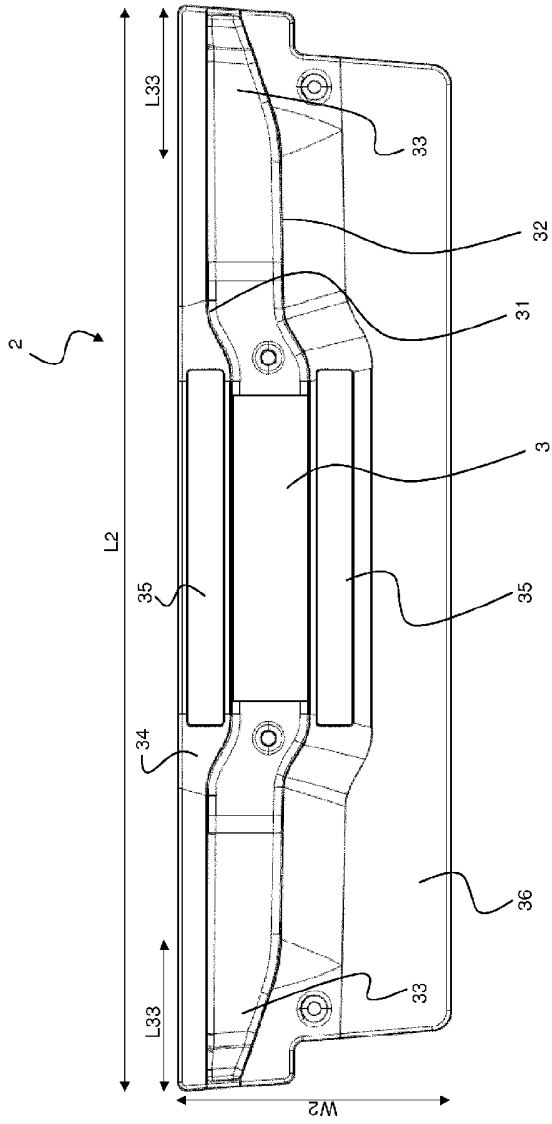

Fig. 4

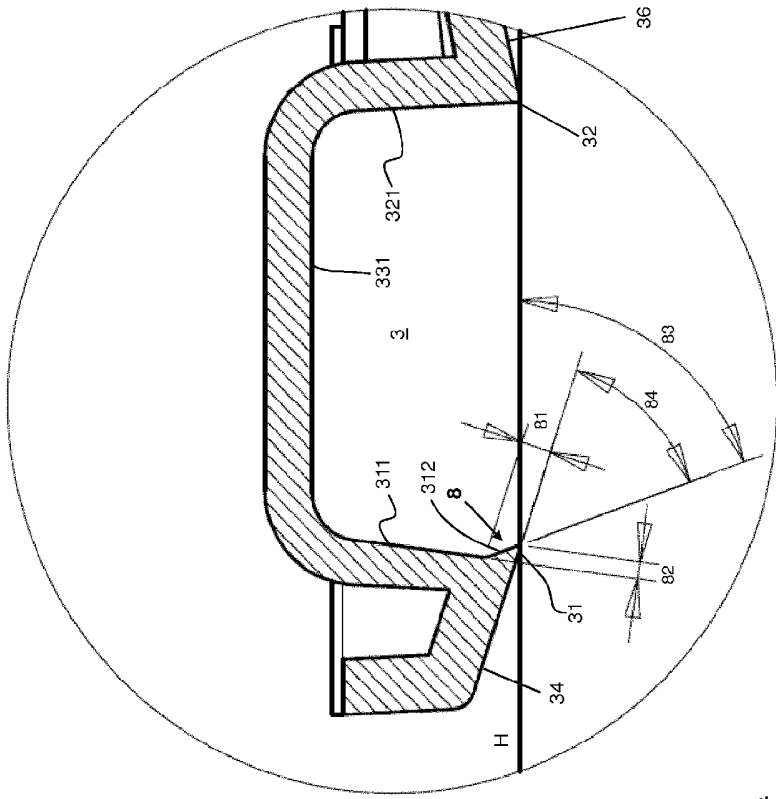

Fig. 5.1

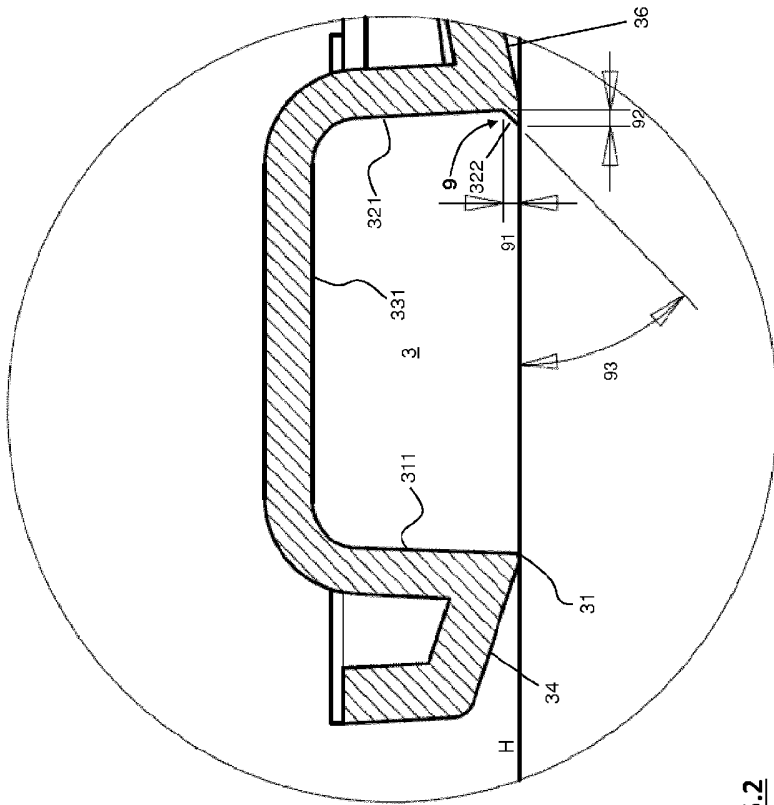

Fig. 5.2

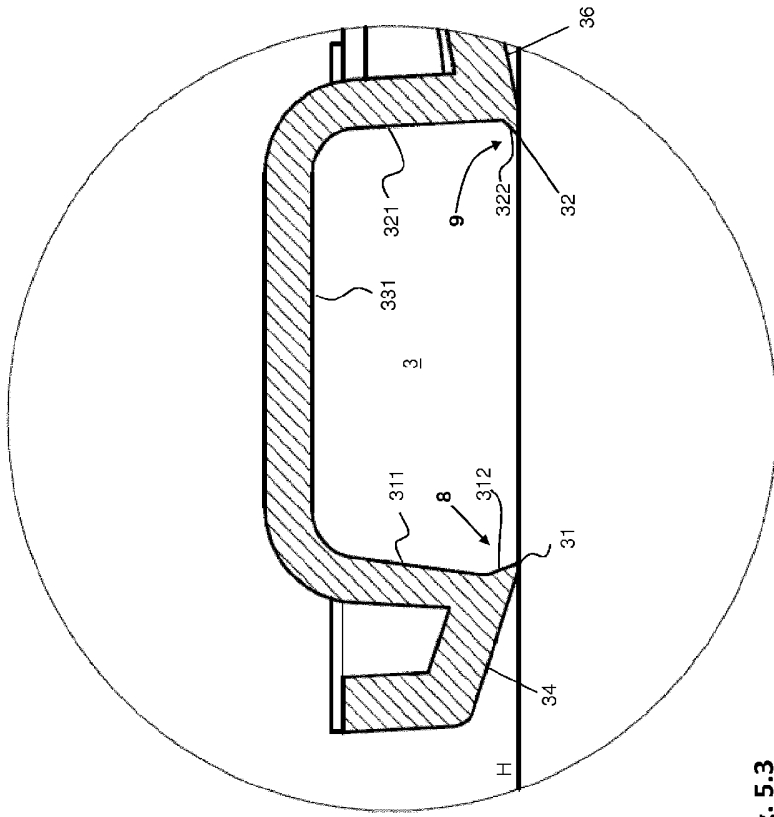

Fig. 5.3