



(51) International Patent Classification:

A61B 17/04 (2006.01) A61F 2/28 (2006.01)
A61F 2/30 (2006.01) A61F 2/46 (2006.01)

(21) International Application Number:

PCT/US2018/022968

(22) International Filing Date:

16 March 2018 (16.03.2018)

(25) Filing Language:

English

(26) Publication Language:

English

(30) Priority Data:

62/472,131 16 March 2017 (16.03.2017) US

(63) Related by continuation (CON) or continuation-in-part (CIP) to earlier application:

US 62/472,131 (CON)
Filed on 16 March 2017 (16.03.2017)

(71) Applicant: CANNUFLOW, INC. [US/US]; 489 Division Street, Campbell, CA 95008 (US).

(72) Inventor: KUCKLICK, Theodore, R.; 489 Division Street, Campbell, CA 95008 (US).

(74) Agent: BACKOFEN, Paul, J.; Crockett & Crockett, PC, 6b Liberty, Suite 145, Aliso Viejo, CA 92656 (US).

(81) Designated States (unless otherwise indicated, for every kind of national protection available):

AE, AG, AL, AM, AO, AT, AU, AZ, BA, BB, BG, BH, BN, BR, BW, BY, BZ, CA, CH, CL, CN, CO, CR, CU, CZ, DE, DJ, DK, DM, DO, DZ, EC, EE, EG, ES, FI, GB, GD, GE, GH, GM, GT, HN, HR, HU, ID, IL, IN, IR, IS, JO, JP, KE, KG, KH, KN, KP, KR, KW, KZ, LA, LC, LK, LR, LS, LU, LY, MA, MD, ME, MG, MK, MN, MW, MX, MY, MZ, NA, NG, NI, NO, NZ, OM, PA, PE, PG, PH, PL, PT, QA, RO, RS, RU, RW, SA, SC, SD, SE, SG, SK, SL, SM, ST, SV, SY, TH, TJ, TM, TN, TR, TT, TZ, UA, UG, US, UZ, VC, VN, ZA, ZM, ZW.

(84) Designated States (unless otherwise indicated, for every kind of regional protection available):

ARIPO (BW, GH, GM, KE, LR, LS, MW, MZ, NA, RW, SD, SL, ST, SZ, TZ, UG, ZM, ZW), Eurasian (AM, AZ, BY, KG, KZ, RU, TJ, TM), European (AL, AT, BE, BG, CH, CY, CZ, DE, DK, EE, ES, FI, FR, GB, GR, HR, HU, IE, IS, IT, LT, LU, LV, MC, MK, MT, NL, NO, PL, PT, RO, RS, SE, SI, SK, SM, TR), OAPI (BF, BJ, CF, CG, CI, CM, GA, GN, GQ, GW, KM, ML, MR, NE, SN, TD, TG).

(54) Title: SYSTEM AND METHOD FOR FIXING SHEET-LIKE MATERIALS TO A TARGET TISSUE

(57) Abstract: The devices, systems and methods herein provide for anchoring of surgical constructs to body tissue. These systems may be used for both biologic implant securement in arthroscopy as well as other sheet and scaffold repair procedures. The system may be used for any soft tissue repair procedure where a synthetic or biologic patch is used, such as joint repair or hernia repair.

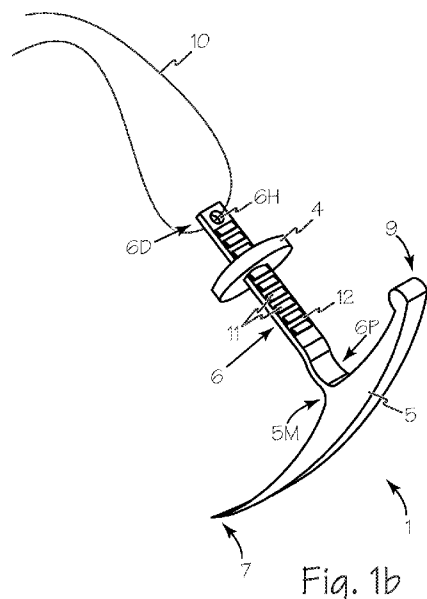

Fig. 1b



Published:

- *with international search report (Art. 21(3))*
- *before the expiration of the time limit for amending the claims and to be republished in the event of receipt of amendments (Rule 48.2(h))*

**System And Method For Fixing Sheet-Like Materials
To A Target Tissue**

This application claims priority to U.S. Provisional Application 62/472,131, filed March 16, 2017.

5 Field of the Inventions

The inventions described below relate to the field of arthroscopic repair of joints.

Background of the Inventions

10 Biologic constructs and other sheet-like surgical implants are growing rapidly in popularity for the repair of joint pathologies. Biologic constructs are a family of biologically derived implants to promote tissue growth or to patch and repair tissue defects and tears. These repairs include the repair of arthritic cartilage, the joining of
15 tendons to bone and the bridging of degenerated rotator cuff in the shoulder. Biologic constructs now occupy an increasingly important place in the orthopedic surgeons armamentarium. One of the key problems with biologic constructs is that the attachment systems have not kept pace
20 with advances in these implants. Staples are among the most common form of biologic sheet attachment but there is concern that simple staples may back out and float around loose in the joint.

Summary

25 The devices, systems and methods described below provide for anchoring of surgical constructs to body tissue. The systems may be used for both biologic implant securement in arthroscopy as well as other sheet and scaffold repair procedures. The system may be used for any soft tissue repair

procedure where a synthetic or biologic patch is used, such as joint repair or hernia repair.

Various implant anchors are described, including a T-bar anchor, a wing shaped anchor and a porcupine anchor. One T-bar anchor uses a strap with teeth that engage a pawl within a locking grommet to secure the sheet implant against the rotator cuff. Another T-bar anchor has an attached suture that connects to a lock button. Another anchor features a sharp end like a curved needle that penetrates the rotator cuff and locks into the tissue when the suture or strap pulls the blunt end backwards. These embodiments securely hold the biologic sheet in place against any suitable tissue such as a rotator cuff, requiring no surgical knot tying, and compress the sheet implant down more securely than a simple staple. The T-bar may go through the rotator cuff or tendon.

The porcupine embodiment is an anchor that has micro molded barbs on the side with a large engaging surface area. This is similar to the way a porcupine quill stays secured in tissue and resists pullout. These microstructured barbs are disposed on a central anchor spike. The head of the anchor comprises a hold-down bar that has additional barbs to hold down the biologic implant sheet.

Brief Description of the Drawings

Figures 1a, 1b and 1c illustrate a T-Bar implant with locking grommet and an implant driver.

Figures 2a and 2b illustrate a lock bar anchor and suture with lock button.

Figures 3a, 3b, 3c, 3d and 3e illustrate a T-bar needle delivery device and T-bar implant.

Figures 4a, 4b, 4c and 4d illustrate a wing anchor and driver.

Figures 5a, 5b and 5c illustrate a porcupine anchor and driver.

5

Detailed Description of the Inventions

Figures 1a, 1b and 1c illustrate a generally T-shaped T-Bar anchor 1 which may be used to secure a sheet like implant such as biological construct 2 to any suitable tissue 3 with a locking grommet 4. The T-Bar anchor comprises implant bar 5 attached at any suitable point such as midpoint 5M to strap 6, thus forming a T-configuration. The implant bar has a sharp end 7 and a blunt or driver end 9. The attachment point is selected to maintain the length 6L of strap 6 to be longer than the distance 5L from the attachment point to the blunt end 9. Strap 6 has a keyhole 6H in distal end 6D for inserting a guide suture such as suture 10. Proximal end 6P of the strap is attached to implant bar 5 at any suitable location between the sharp end and the blunt end such as midpoint 5M. Strap 6 has teeth 11 along one or more sides such as side 12 and the teeth engage locking grommet 4 as in a ratchet. The teeth engage any suitable element within the locking grommet such as a pawl or the interior surface of the locking grommet.

In use, an implant sheet is apposed to tissue at a suitable treatment site. For example, Figure 1a shows a biologic construct 2 apposing rotator cuff tissue 3. The user pulls the guide suture 10 toward blunt end 9 of implant bar 5, which in turn bends or folds strap 6 parallel to the implant bar as illustrated in folded position 13 of Figure 1a. The user then holds T-bar anchor 1 with the pointed end of the implant bar pointed at implant sheet. Implant driver 14 shown has a distal tip 14D which engages the bar implant blunt end 9. Implant driver 14 is used to push the blunt end of the

implant bar, thus driving the sharp end of the implant bar through implant sheet 2 and rotator cuff tissue 3. Once implant bar 5 has reached a desirable position, the user withdraws the driver which allows the implant bar to return to a T-configuration with strap 6 perpendicular to implant bar 5 with the distal end 6D of the strap accessible through the tissue and implant sheet. The user retaining control over guide suture 10 provides insurance against having the entirety of T-bar anchor 1 pass through the implant sheet and the tissue and be unable to be secured with a locking grommet. If necessary, when the strap ends up below sheet 2 and or tissue 3 the user will pull suture 10 to draw the strap back out of the perforation created during insertion of the T-bar through the biological construct and the tissue. Locking grommet 4 is then pushed over distal end 6D of the strap and the lock grommet is pushed along the strap toward the proximal end of the strap engaging teeth 11 to secure the sheet implant against the rotator cuff tissue. Once installed, the perpendicular orientation of implant bar 5 relative to strap 6 results in a generally T-shaped T-bar anchor 1.

Figures 2a and 2b illustrate a lock bar anchor 20 which comprises lock bar 21, suture 22 and lock button 23. Lock bar 21 has a sharp penetrating end 21A and a blunt drive end 21B. The bar has one or two holes 24 in any suitable location such as mid point 21M to engage suture 22 in loop fashion. Suture 22 is fed through one hole 24 and back out through the other hole 24 as shown, so that it may draw the bar toward the lock button securing implant sheet 2 apposing tissue 3 as illustrated in Figure 2b.

In use, the implant sheet 2 is positioned apposing tissue 3 at any suitable treatment site. For example, Figure 2b shows biologic sheet 2 apposing rotator cuff tissue 3. The user extends suture 22 flat along the lock bar 21 with the suture extending through indent or channel 25 in blunt drive

end 21B. The user holds lock bar 21 with pointed end 21A pointing to securement location 26 through implant sheet 2 and drives the lock bar anchor through the implant sheet and the tissue until drive end 21B passes through tissue 3. When all of lock bar 21 passes through tissue 3 the lock bar is allow
5 to rotate until it is perpendicular to suture 22. The user then pulls the sutures taught and inserts the sutures through a lock button to draw the bar and lock button together, thus securing the sheet to the rotator cuff. Once installed, the
10 perpendicular orientation of lock bar 21 relative to suture 22 results in a generally T-shaped lock bar anchor 20.

Figures 3a, 3b, 3c, 3d and 3e illustrate a T-bar implant anchor 30, driver 31 and the T-bar anchor secured to tissue 3. T-bar 32 has a suture such as suture 33 secured at the
15 longitudinal center of the T-bar to form the T-bar implant. A sliding lock grommet such as grommet 34 is slid down suture 33 to secure an implant sheet to any suitable tissue such as tissue 3. T-bar driver 31 has a sharp distal end 35 and a hollow space 36 for holding the T-bar implant just proximal to
20 the sharp distal end of the T-bar driver. The T-bar driver device has a sliding bar 37 operably connected to the handle for ejecting or driving the T-bar implant into the surgical space.

In use, biologic sheet 2 is positioned apposing tissue 3
25 at any suitable treatment site. For example, Figure 3e shows biologic sheet 2 apposing tendon 3. The user loads the T-bar implant into T-bar driver 31 as shown in Figures 3b and 3c. The user slidably engages the delivery device slide 37 to drive the T-bar implant through the biologic sheet and tendon.
30 The user withdraws the T-bar driver leaving T-bar 32 positioned under the tendon with suture 33 attached and extending through the tendon and sheet. The user pulls suture 33 through lock grommet 34 to draw the T-bar and lock grommet together, thereby securing the sheet to the tendon. Once

installed, the perpendicular orientation of T-bar implant 32 relative to suture 33 results in a generally T-shaped T-bar anchor 30.

Figures 4a, 4b, 4c and 4d illustrate a generally T-shaped wing anchor 40 as well as accessories and a driver. Wing anchor 40 has a center post, post 41 with locking ratchet teeth such as teeth 42. Two wings, wings 43, resiliently spring outwardly and extend from center post 41 at its distal end, post root 44. The orientation of wings 43 relative to center post 41 results in generally T-shaped wing anchor 40. Center post 41 has a keyhole, hole 45 positioned at its proximal end 41P for engaging suture 46. Anchor driver 47 has a hollow portion 47H at its distal end sized and dimensioned to engage wing anchor 40 at post root 44 and enclose post 41 as shown in Figure 4c. Wing anchor 40 also includes an obturator tip 40T for penetrating implant sheets and tissue.

In use, biologic sheet 2 is positioned apposing tissue 3 at any suitable treatment site. For example, Figure 4d shows implant sheet 2 apposing rotator cuff 3. The user inserts the suture 46 through hole 45 and holds the suture off to the side. The user holds wing anchor 40 with the pointed obturator tip 40T over the implant sheet. The driver hollow portion is inserted over the wing anchor center post. The user pushes the driver to drive the wing anchor through the implant sheet and tissue 3 into the securement site. Once the wing anchor has fully penetrated tissue 3 the wings will spring away from the driver and post. The user removes the driver while still holding on to the suture. The suture is fed through lock grommet 48 and the lock grommet is pushed distally on the center post to sandwich the lock grommet against the implant sheet and retain the implant sheet in contact with the tissue.

Figures 5a, 5b and 5c illustrate a generally T-shaped porcupine anchor 50 and driver 51. Flexible "porcupine" or microstructured barbs such as barbs 52 are disposed on a central anchor spike 53 along with fixed ratchet teeth 54.

5 The head of anchor 50 comprises a hold-down bar 55, which has side stakes 55A and 55B at opposite ends of the hold-down bar. The combination of central anchor spike 53 and hold-down bar 55 result in a generally T-shaped porcupine anchor 50. Central anchor spike 53 also includes a suture channel or
10 keyhole 56 in the proximal end for a guide suture. Driver 51 is used to push the porcupine anchor into position through any suitable implant sheet to engage tissue with the flexible porcupine quills and the ratchet teeth engaging the tissue and resisting pullout. The distal end of the driver, distal end
15 51D includes anchor mating end 57 sized and dimensioned to frictionally engage hold-down bar 55.

While the preferred embodiments of the devices and methods have been described in reference to the environment in which they were developed, they are merely illustrative of the
20 principles of the inventions. The elements of the various embodiments may be incorporated into each of the other species to obtain the benefits of those elements in combination with such other species, and the various beneficial features may be employed in embodiments alone or in combination with each
25 other. Other embodiments and configurations may be devised without departing from the spirit of the inventions and the scope of the appended claims.

I claim:

1. An implant anchor comprising:

a generally t-shaped body having a central post
perpendicularly secured to a bar;

5 a locking grommet engaging the central post.

2. The implant anchor of claim 1 wherein the central post
further comprises a plurality of ratchet teeth.

3. The implant anchor of claim 1 wherein the central post is
a suture.

10 4. The implant anchor of claim 1 wherein the central post is
a strap.

5. The implant anchor of claim 4 wherein the strap further
comprises a plurality of ratchet teeth.

6. An implant anchoring system comprising:

15 a generally t-shaped body having a central post
perpendicularly secured to a bar;

a locking grommet engaging the central post; and
an anchor driver.

20

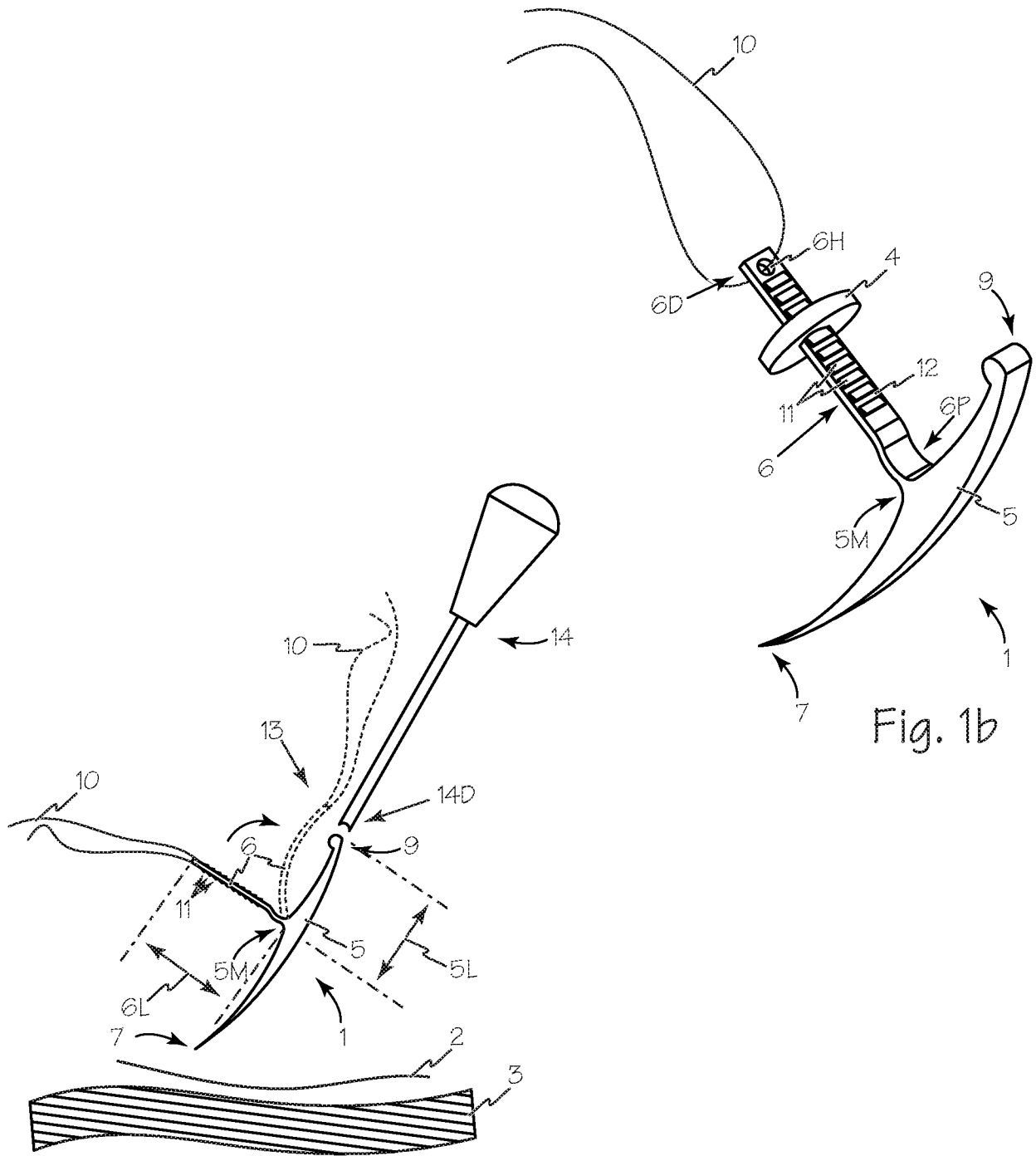

Fig. 1a

Fig. 1b

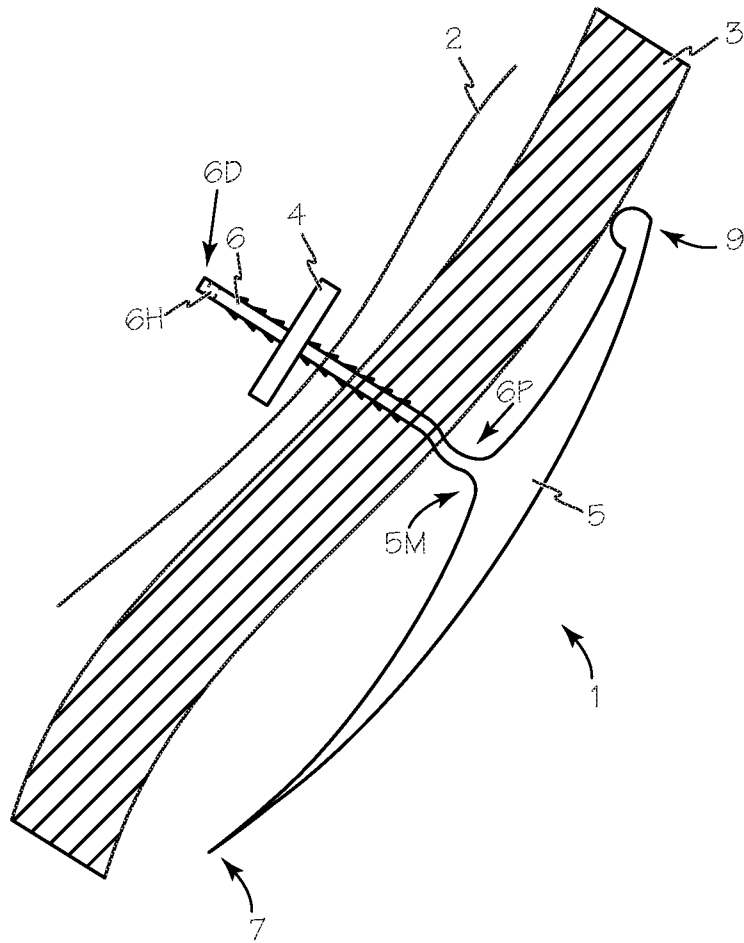

Fig. 1c

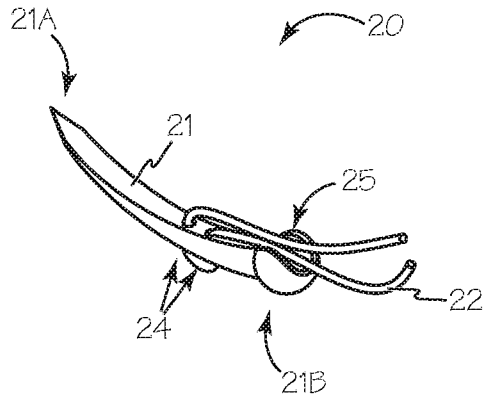

Fig. 2a

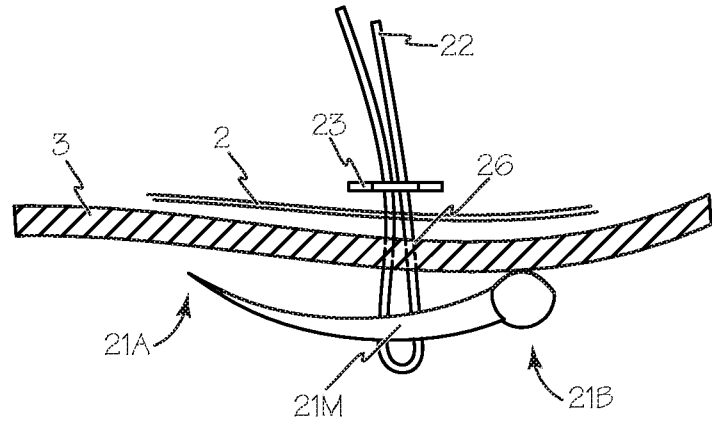
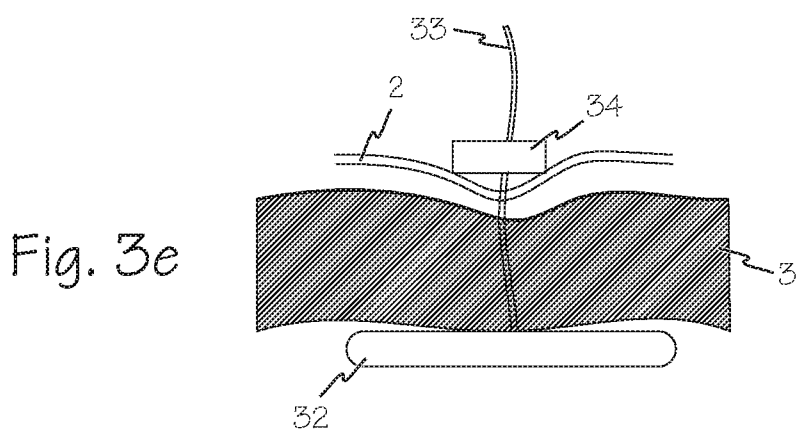
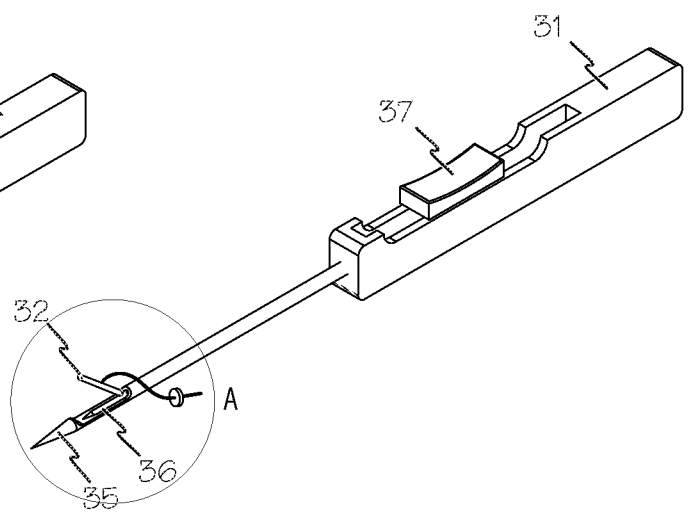
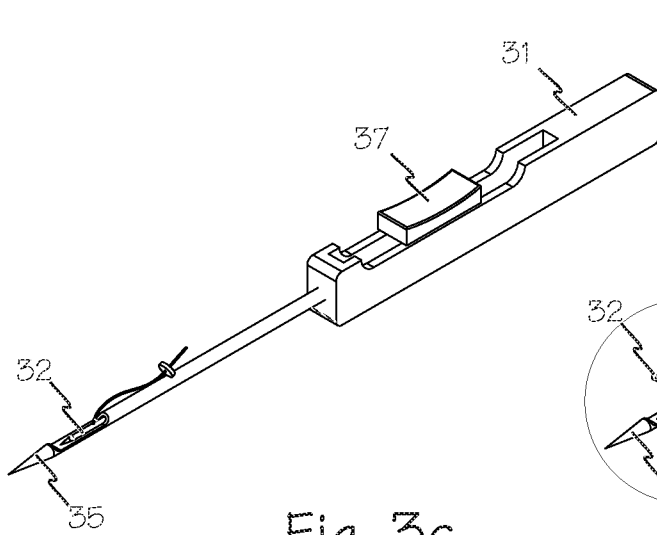
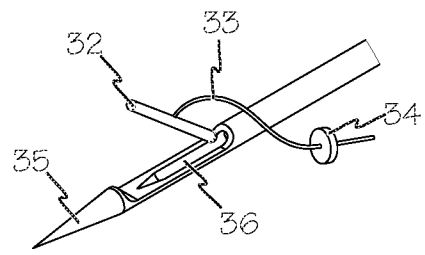
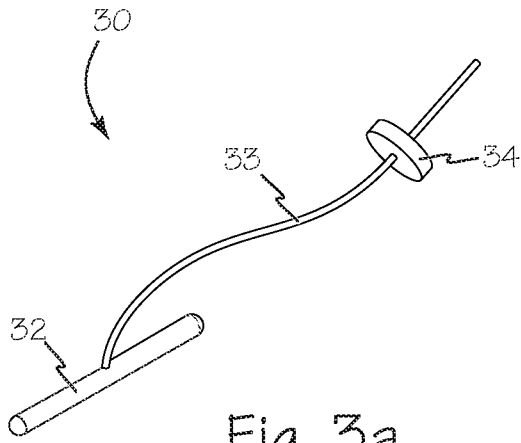

Fig. 2b



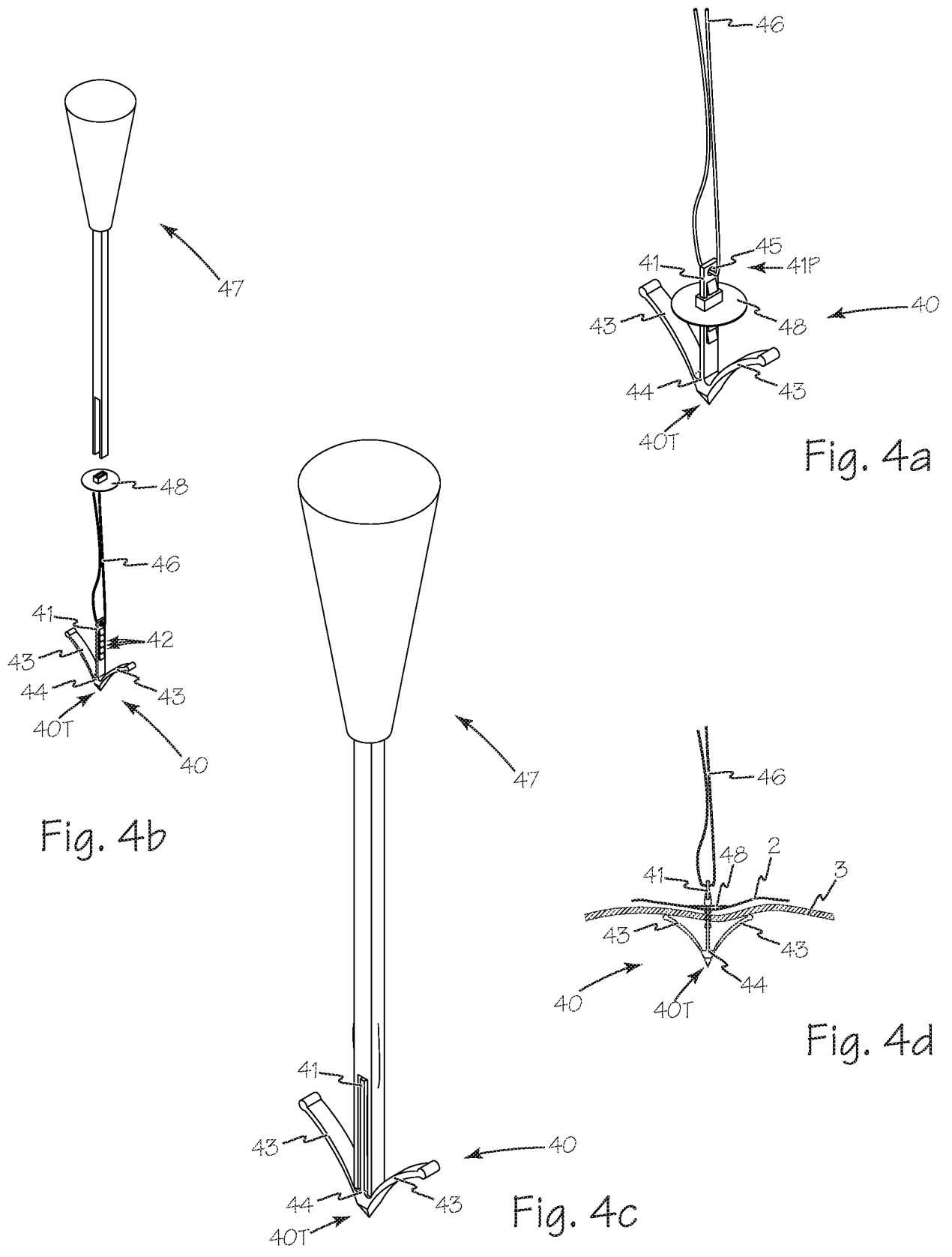

Fig. 4a

Fig. 4b

Fig. 4d

Fig. 4c

6/6

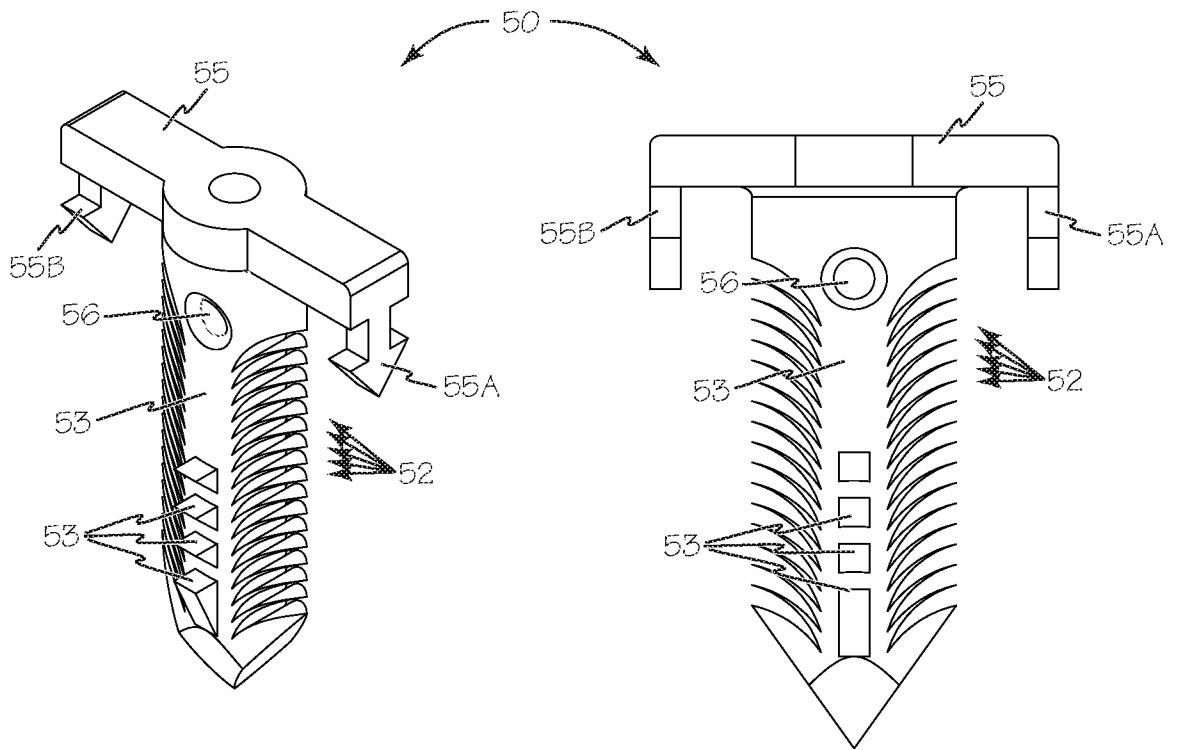

Fig. 5a

Fig. 5b

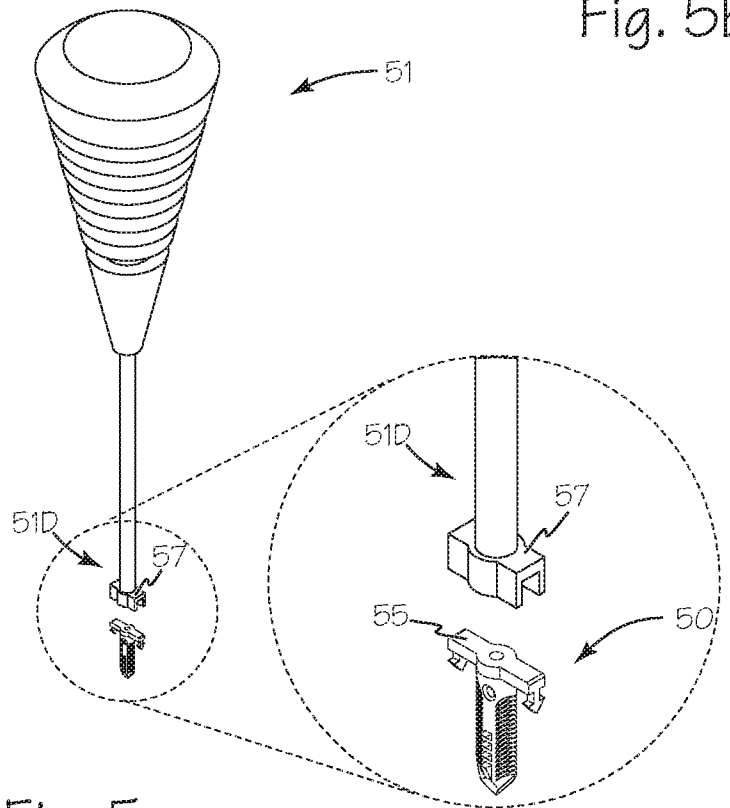

Fig. 5c

A. CLASSIFICATION OF SUBJECT MATTER**A61B 17/04(2006.01)i, A61F 2/30(2006.01)i, A61F 2/28(2006.01)i, A61F 2/46(2006.01)i**

According to International Patent Classification (IPC) or to both national classification and IPC

B. FIELDS SEARCHED

Minimum documentation searched (classification system followed by classification symbols)

A61B 17/04; A61M 31/00; A61B 17/00; A61B 17/88; A61B 17/08; A61F 2/30; A61F 2/28; A61F 2/46

Documentation searched other than minimum documentation to the extent that such documents are included in the fields searched

Korean utility models and applications for utility models

Japanese utility models and applications for utility models

Electronic data base consulted during the international search (name of data base and, where practicable, search terms used)

eKOMPASS(KIPO internal) & Keywords: implant anchor, T-shape body, perpendicular, locking grommet, suture, strap, driver

C. DOCUMENTS CONSIDERED TO BE RELEVANT

Category*	Citation of document, with indication, where appropriate, of the relevant passages	Relevant to claim No.
X	US 5269809 A (HAYHURST, JOHN O. et al.) 14 December 1993 See column 1, line 12 - column 7, line 22; and figure 8.	1-6
X	US 8070743 B2 (KAGAN, JONATHAN et al.) 06 December 2011 See the whole document.	1-6
A	US 7226469 B2 (BENAIVITZ, WILLIAM C. et al.) 05 June 2007 See the whole document.	1-6
A	US 2009-0281568 A1 (CENDAN, JUAN CARLOS et al.) 12 November 2009 See the whole document.	1-6
A	US 2009-0192529 A1 (KAVENEY, MICHAEL) 30 July 2009 See the whole document.	1-6

 Further documents are listed in the continuation of Box C. See patent family annex.

* Special categories of cited documents:

"A" document defining the general state of the art which is not considered to be of particular relevance

"E" earlier application or patent but published on or after the international filing date

"L" document which may throw doubts on priority claim(s) or which is cited to establish the publication date of another citation or other special reason (as specified)

"O" document referring to an oral disclosure, use, exhibition or other means

"P" document published prior to the international filing date but later than the priority date claimed

"T" later document published after the international filing date or priority date and not in conflict with the application but cited to understand the principle or theory underlying the invention

"X" document of particular relevance; the claimed invention cannot be considered novel or cannot be considered to involve an inventive step when the document is taken alone

"Y" document of particular relevance; the claimed invention cannot be considered to involve an inventive step when the document is combined with one or more other such documents, such combination being obvious to a person skilled in the art

"&" document member of the same patent family

Date of the actual completion of the international search

10 July 2018 (10.07.2018)

Date of mailing of the international search report

10 July 2018 (10.07.2018)

Name and mailing address of the ISA/KR

International Application Division

Korean Intellectual Property Office

189 Cheongsa-ro, Seo-gu, Daejeon, 35208, Republic of Korea

Facsimile No. +82-42-481-8578

Authorized officer

Kim, Yeonkyung

Telephone No. +82-42-481-3325



INTERNATIONAL SEARCH REPORT

Information on patent family members

International application No.

PCT/US2018/022968

Patent document cited in search report	Publication date	Patent family member(s)	Publication date
US 5269809 A	14/12/1993	CA 2046010 A1	03/01/1992
		CA 2046010 C	14/05/2002
		EP 0464480 A1	08/01/1992
		EP 0464480 B1	29/03/1995
		JP 04-231946 A	20/08/1992
		JP 3178862 B2	25/06/2001
		KR 10-0178358 B1	01/04/1999
		KR 10-1992-0002095 A	28/02/1992
		US 5041129 A	20/08/1991
		US 8070743 B2	06/12/2011
AU 2003-291087 A1	15/06/2004		
EP 1555970 A1	27/07/2005		
EP 1555970 B1	24/09/2014		
EP 1709508 A2	11/10/2006		
EP 1750595 A2	14/02/2007		
EP 1750595 A4	22/10/2008		
EP 2010270 A2	07/01/2009		
EP 2010270 A4	09/07/2014		
US 2004-0092892 A1	13/05/2004		
US 2004-0148034 A1	29/07/2004		
US 2005-0049718 A1	03/03/2005		
US 2005-0096750 A1	05/05/2005		
US 2005-0240279 A1	27/10/2005		
US 2006-0206063 A1	14/09/2006		
US 2006-0293742 A1	28/12/2006		
US 2007-0010794 A1	11/01/2007		
US 2007-0010866 A1	11/01/2007		
US 2007-0198074 A1	23/08/2007		
US 2009-0149871 A9	11/06/2009		
US 2012-0209164 A1	16/08/2012		
US 2015-0366693 A1	24/12/2015		
US 2017-0056227 A1	02/03/2017		
US 7037344 B2	02/05/2006		
US 7220284 B2	22/05/2007		
US 7794447 B2	14/09/2010		
US 7837669 B2	23/11/2010		
US 7846138 B2	07/12/2010		
US 7892214 B2	22/02/2011		
US 8012135 B2	06/09/2011		
US 8012140 B1	06/09/2011		
US 8182459 B2	22/05/2012		
US 8968270 B2	03/03/2015		
US 9060844 B2	23/06/2015		
US 9561127 B2	07/02/2017		
US 9839546 B2	12/12/2017		
WO 2004-041133 A1	21/05/2004		
WO 2004-046109 A2	03/06/2004		
WO 2004-046109 A3	15/07/2004		

INTERNATIONAL SEARCH REPORT

Information on patent family members

International application No.

PCT/US2018/022968

Patent document cited in search report	Publication date	Patent family member(s)	Publication date
		WO 2005-065412 A2	21/07/2005
		WO 2005-065412 A3	02/08/2007
		WO 2005-110280 A2	24/11/2005
		WO 2005-110280 A3	05/01/2006
		WO 2007-136468 A2	29/11/2007
		WO 2007-136468 A3	06/03/2008
US 7226469 B2	05/06/2007	AT 372724 T	15/09/2007
		AT 498360 T	15/03/2011
		AU 2006-213955 A1	29/03/2007
		AU 2006-213955 B2	15/12/2011
		DE 60037696 T2	08/01/2009
		DE 60222311 T2	21/08/2008
		EP 1031321 A1	30/08/2000
		EP 1031321 B1	09/01/2008
		EP 1234544 A2	28/08/2002
		EP 1234544 A3	02/01/2004
		EP 1234544 B1	12/09/2007
		EP 1584296 A1	12/10/2005
		EP 1762186 A2	14/03/2007
		EP 1762186 A3	26/12/2007
		EP 1762186 B1	16/02/2011
		EP 1762187 A1	14/03/2007
		EP 1762187 B1	22/10/2014
		EP 1797829 A1	20/06/2007
		EP 2630921 A1	28/08/2013
		EP 2630921 B1	25/05/2016
		JP 2007-075616 A	29/03/2007
		JP 5368669 B2	18/12/2013
		KR 10-1233954 B1	15/02/2013
		KR 10-2008-0055815 A	19/06/2008
		US 2005-0222618 A1	06/10/2005
		US 2007-0060922 A1	15/03/2007
		US 2007-0073299 A1	29/03/2007
		US 2007-0150003 A1	28/06/2007
		US 2013-0296937 A1	07/11/2013
		US 2014-0121701 A1	01/05/2014
		US 2015-0342596 A1	03/12/2015
		US 2017-0164940 A1	15/06/2017
		US 2017-0231618 A1	17/08/2017
		US 6517564 B1	11/02/2003
		US 7211088 B2	01/05/2007
		US 8801755 B2	12/08/2014
		US 8821541 B2	02/09/2014
		US 9521999 B2	20/12/2016
		US 9526493 B2	27/12/2016
US 2009-0281568 A1	12/11/2009	WO 2007-147057 A2	21/12/2007
		WO 2007-147057 A3	04/12/2008

INTERNATIONAL SEARCH REPORT

Information on patent family members

International application No.

PCT/US2018/022968

Patent document cited in search report	Publication date	Patent family member(s)	Publication date
US 2009-0192529 A1	30/07/2009	None	