

T. L. & T. J. STURTEVANT.
GRINDING MILL.

No. 522,698.

Patented July 10, 1894.

Fig- 2-

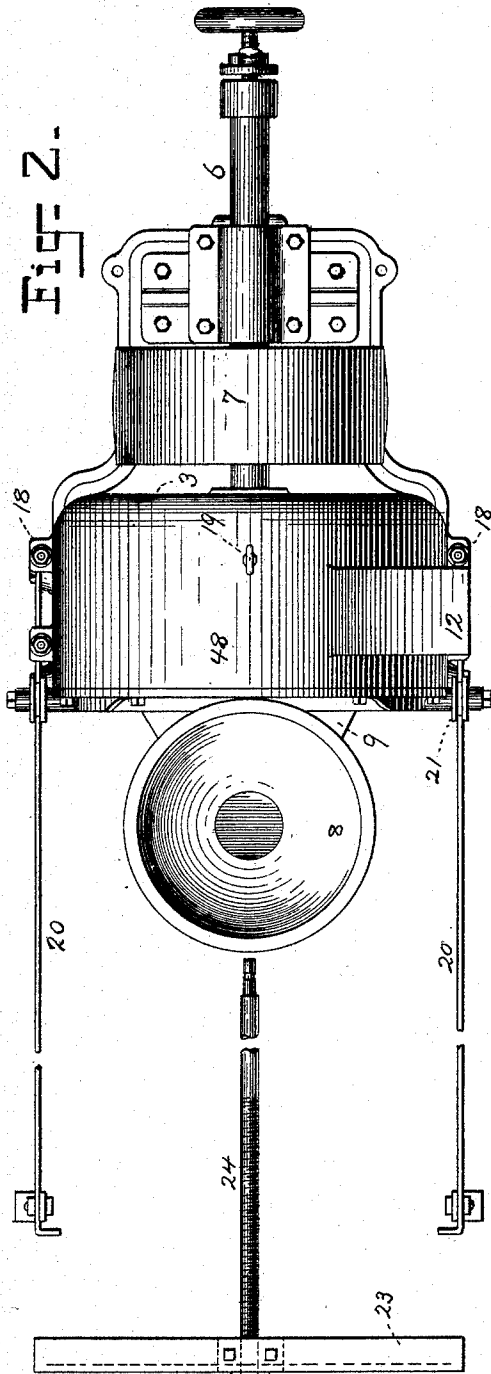
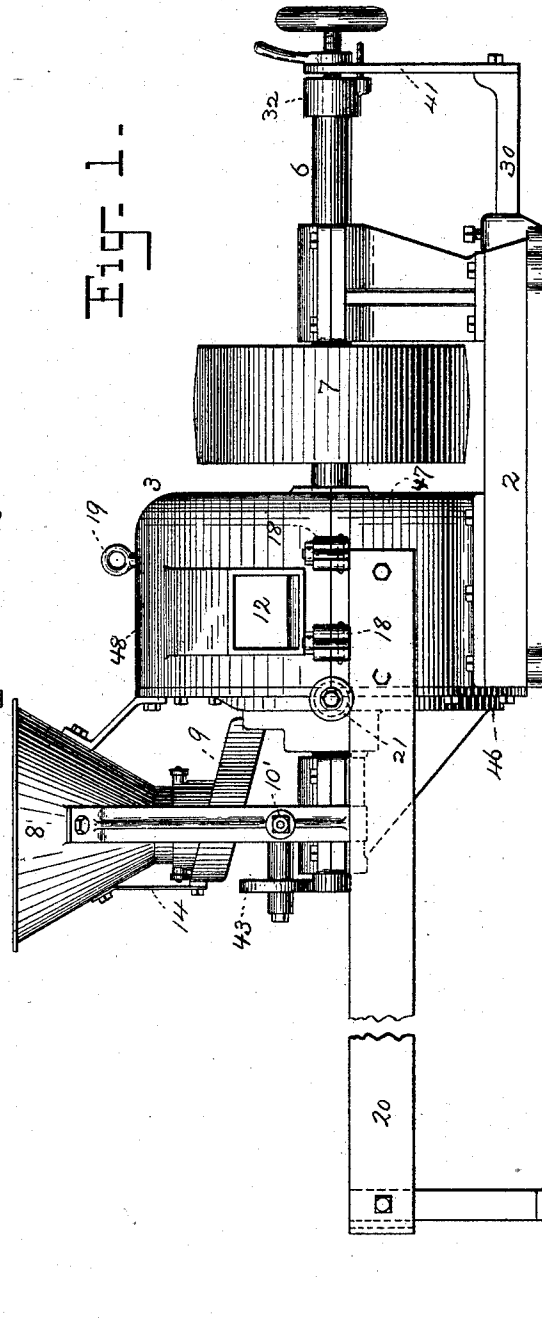

Fig- 1-



Witnesses.
John F. Nelson.
Francis C. Steward

Inventors
Thos. L. Sturtevant.
Thos. J. Sturtevant.
 by *H. C. Lodge Atty.*

T. L. & T. J. STURTEVANT. GRINDING MILL.

No. 522,698.

Patented July 10, 1894.

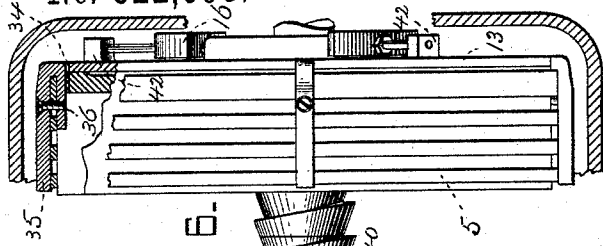

Fig-5-

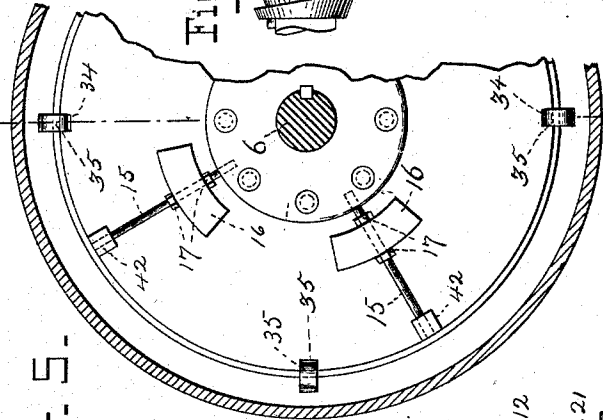

Fig-5-

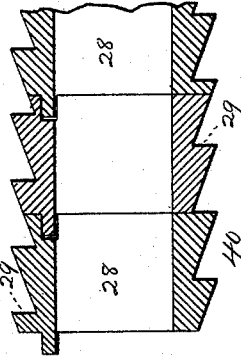

Fig-8-

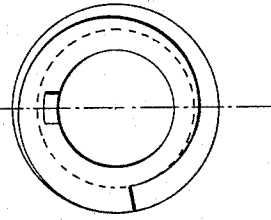

Fig-7-

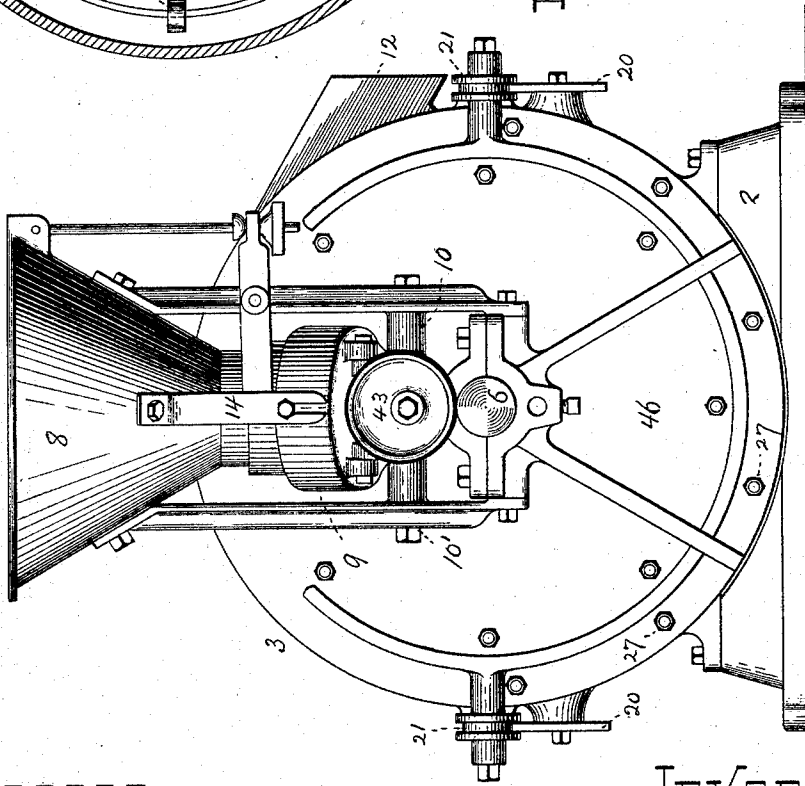

Fig-3-

Witnesses.

John F. Nelson.

Francis C. Stenwood

Inventors

Thos. L. Sturtevant.

Thos. J. Sturtevant.

by H. C. Lodge Atty.

(No Model.)

3 Sheets—Sheet 3.

T. L. & T. J. STURTEVANT. GRINDING MILL.

No. 522,698.

Patented July 10, 1894.

Fig-4-

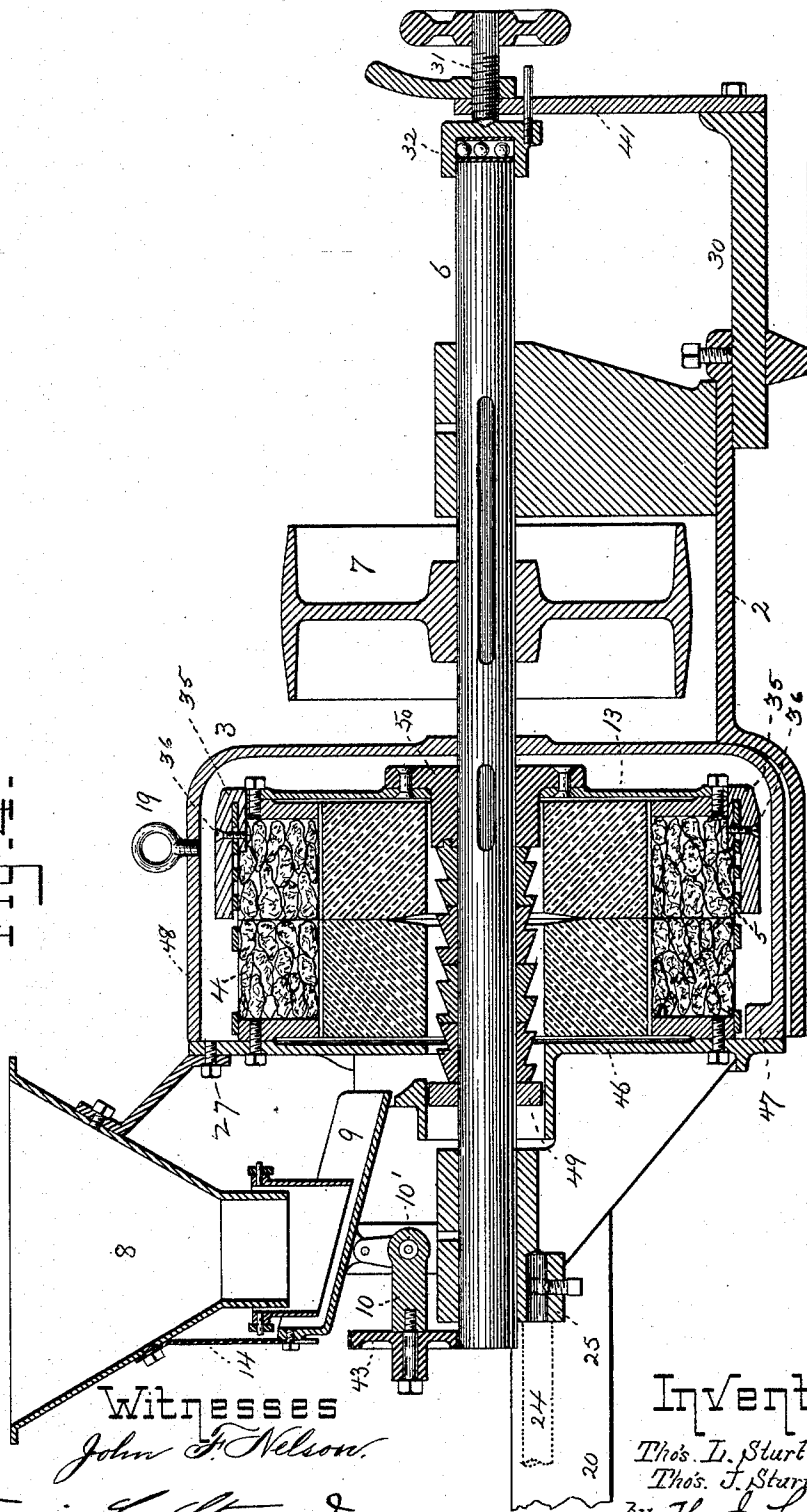

Witnesses
John F. Nelson.
Francis E. Stanwood.

Inventors
Thos. L. Sturtevant,
Thos. J. Sturtevant,
 by *H. C. Lodge Atty.*

UNITED STATES PATENT OFFICE.

THOMAS L. STURTEVANT AND THOMAS J. STURTEVANT, OF QUINCY,
MASSACHUSETTS.

GRINDING-MILL.

SPECIFICATION forming part of Letters Patent No. 522,698, dated July 10, 1894.

Application filed August 26, 1893. Serial No. 484,115. (No model.)

To all whom it may concern:

Be it known that we, THOMAS L. STURTEVANT and THOMAS J. STURTEVANT, citizens of the United States, residing at Quincy, in the
5 county of Norfolk and State of Massachusetts, have invented certain new and useful Improvements in Grinding-Mills; and we do hereby declare the following to be a full, clear, and exact description of the invention, such as will
10 enable others skilled in the art to which it appertains to make and use the same, reference being had to the accompanying drawings, and to figures of reference marked thereon, which form a part of this specification.

15 This invention relates to grinding-mills, particularly that class provided with a stationary bed-stone or grinding disk, and a revolving stone termed a "runner."

Our invention is embodied in the peculiar
20 form and arrangement of various elements whereby the adjustments are facilitated, and the operation and effectiveness of the mill as an entirety are improved.

Our improvements relate severally to mechanism for conveying the material between
25 the grinding disks; to a peculiar method of mounting the runner, likewise to the device for balancing said runner, also to the manner of operating a shaking feed leading from the
30 hopper.

Other prominent and characteristic features will be mentioned in detail and more fully described in the body of the specification.

35 The drawings herewith presented, represent in Figure 1 a side elevation showing the jointed sectional mill casing. Fig. 2 is a plan and Fig. 3 an end elevation, both reduced. Fig. 4 is a longitudinal, vertical section of a
40 grinding mill embodying our invention. Fig. 5 is a rear end view of a portion of the runner showing the balancing device. Fig. 6 is a sectional view of the clearer and the casing in section, with the runner in elevation. Figs.
45 7 and 8 are the detail views showing the manner of interlocking the several parts which go to make up the continuous screw feed, Fig. 8 being in section on the plane indicated in Fig. 7.

50 In the accompanying drawings, we have shown a grinding mill of the class above

premised and composed of a stationary bed piece 2 on which is placed a cylindrical casing 3, adapted to contain the grinding agencies in the form of two disks 4, 5, respectively—a bed-stone and a runner. Longitudinally of the apparatus is mounted a shaft 6
55 which extends centrally through the casing transversely of the latter; said shaft is furnished with a driving pulley 7 and arranged
60 for endwise adjustment to compensate for wear of the stones, and likewise to regulate the degree of fineness in the grinding. The material is fed into a hopper 8 and thence
65 conveyed by a shaking chute 9 to a central feed, since the substance to be ground enters the eyes of the disks and is conveyed radially outward between the stones by centrifugal action during the process of grinding. Having reached the space which exists
70 circumferentially between the grinding disks and the casing 3, it is discharged through the opening 12 in said casing, whence it is conveyed to any suitable storage.

As before stated, the casing contains two
75 grinding disks of any suitable material. The bed-stone 4, so-called, is stationary and bolted to the casing, while the runner 5 by its attachments is adapted to revolve by means of the shaft. One of the most notable features of
80 our invention is involved in the method of mounting the runner, and consists in affixing to said shaft within the casing a flexible plate 13 to which the revoluble disk is bolted. When the runner is forced up against the bed-
85 stone, it stays there, however much the shaft may vibrate, since the shaft is allowed some movement due to the flexibility of the plate 13. Should the stone be rigidly secured to the shaft as is usual, and the shaft be sprung,
90 the stone springs with it, while the faces of the stones separate; hence fine grinding is impossible. Our plan insures that the runner will not be deviated from its proper path of rotation by any moderate movement of the
95 driving shaft.

A further advantage in affixing the runner to a flexible plate is that it allows the revoluble disk to adjust itself in a horizontal or vertical plane, since centrifugal action always
100 tends to hold it in such planes, whether the shaft is exactly true or not. Moreover this

flexible plate affords a certain amount of elasticity, and relieving springs are not necessary.

To provide a balancing device in order to counteract any tendency to throw or travel eccentrically, due to improper distribution of material composing the disk, a series of bosses 42 are formed on the circumference of the flexible plate, while a series of screw-threaded rods 15 are radially positioned, as shown in Fig. 5. Adjustable weights 16 are held in any desired position upon said rods by means of holding nuts 17. In this way, a positive adjustment is easily effected.

The next point of novelty is contained in the hopper-chute 9 and the mechanism for producing a silent feed. Reference to Figs. 1 and 4 shows the chute 9 attached to a rocker-arm 10 pivoted at 10'. Oscillations of this arm are produced by means of an eccentric disk 43, adjusted to bear upon the main shaft and be revolved thereby, the face of this disk is covered with leather or other soft material, to prevent noisy contact of the two metallic surfaces. In lieu of the above, the shaft may be covered. A spring 14 is attached at one end to the hopper, while its free end is adjustably secured to the rear of the chute 9 and holds the eccentric disk in contact with the shaft, which gives the chute a quick spring-like action and compels the material to advance in a positive manner.

Another feature of our mill is involved in the arrangement of the casing, which is composed of a removable end-head 46, a lower semi-cylindrical half 47, and a similar upper half or cap 48.

Our improvements in these particulars are to afford ready means for repairs of the grinding stones or the substitution of new ones for those worn out. As will be seen in Figs. 2 and 3, the cap is secured to the lower part by bolts and nuts 18, while an eyebolt 19 enables said cap to be easily raised by a chain-lift or otherwise. In connection with the removal of the end-head together with the bed-plate, we have provided two parallel guides 20 adapted to receive rollers 21 secured to said end-head, while a removable yoke 23 which interlocks the bent ends of the guides carries a screw-threaded rod 24, one end of which is attached in the tubular boss 25, see Fig. 1. The opposite extremity is furnished with a revoluble hand nut 26. Thus, assuming the head is to be drawn out, the end bolts 27 are removed, the yoke 23 slipped into the bent terminals of the guides, while the end of the rod 24 engages the tubular boss 25 in the frame; the set-screw is then set up. The sleeve nut 26 is now revolved and the rod is retracted, thereby pulling forward the head which is supported by the rollers which travel on the guides. After this act is performed, the cap is lifted off and then when released from connecting parts, the entire shaft with the runner is free to be taken out. No other parts of the mill require to be similarly disturbed, and the ease with which these

several steps are effected—separation of the casing into its several sections; removal of the end-head with the bed-plate, and lifting out of the shaft and the runner—shows the importance of these features of our invention.

Since this class of grinding mill is provided with a central feed, and because of certain difficulties which arise under the present form of feed, we have inclosed the shaft for a certain required distance with a sleeve 40 composed of interlocking annular sections 28, exteriorly screw-threaded, see Figs. 7 and 8 for detail. In lieu of forming this with the usual screw-thread, saw-tooth in cross section, we have provided a ratchet section; hence the vertical face 29 serves as a support or backing and a direct thrust obliquely forward is imparted to all the particles. As the grinding disks become worn, sections of the sleeve-feed are removed by slipping them off the end of the shaft, while they are held in place by a collar 49 fitted with a set-screw. To compel rotation of this sleeve 40 in unison with the shaft, the section adjacent to the hub 50 is adapted to fit a recess in the face of the latter. Thus the several sections are not only interlocked with each other but with the hub, while the collar 49 at the opposite end holds them in place.

To provide for end thrust of the shaft in the event of large foreign particles passing between the stones, and to compel the runner to be constantly pushed toward the bed plate, a horizontal bar 30 is adjustably secured in the frame of the mill, while an upright spring-plate 41 is bolted thereto and supports at its free end a screw bolt 31. This latter regulates the position of a journal-box 32 which is prevented from rotation by the pin which enters the spring-plate.

In the operation of this grinding mill, the material is poured into the hopper, and is then fed by the aid of the shaking chute to the central sectional sleeve-feed, said material entering the eye of the bed-plate, whence it is passed outwardly between the stones to the circumference and finally by mechanism compelled to emerge through the discharge orifice 12 in the shell of the casing. In order to prevent the ground material from packing together and remaining in the space in the casing between the latter and the grinding disks, and further to compel its discharge, a series of clearers 35 are detachably secured to the runner. Said device consists of a straight bar or rod bent upon itself as shown in Fig. 6, and bored transversely to receive a retaining screw 36. The underturned part of said clearer is to enter an aperture 34 in the runner, while the two parts are to straddle one of the bands which girdle the stone, the longer part being of a length about equal to the thickness of the stone. By this construction the clearer can be removed very easily when worn out, by taking out the holding screw, and then withdrawing the clearer

until the bent part is disengaged from the material composing the runner.

What we claim is—

1. In grinding mills the combination with the bed-stone, a revoluble shaft, and a flexible plate affixed transversely thereto, of a runner stone bolted to said flexible plate, substantially as shown.

2. The combination with an inclosing casing, a stationary bed-stone therewithin, a rotary shaft, and a hub affixed to said shaft, of a flexible plate upon said hub, and a runner stone bolted to the plate, substantially as and for purposes explained.

3. In a grinding mill, a rotary shaft, a runner stone carried thereby, a stationary bed-stone, and a hopper having a feed-chute, combined with a rocker-arm connected with said chute, an eccentric disk mounted upon said arm and resting on the shaft, and a plate-spring adjustably secured to the rear end of the chute, substantially as stated.

4. In a grinding mill, the combination with a rotary shaft, a runner stone carried thereby, and a stationary bed stone, of a hopper, a rising and falling feed chute, a spring arm adjustably connecting said hopper and chute, a bell-crank lever pivoted beneath said chute and having one arm connected therewith, and mechanism which connects said bell-crank lever with the said rotary shaft to vibrate the chute, substantially as described.

5. In a grinding mill the combination with a revoluble shaft, suitable grinding agencies, and a stationary hopper, of a feed-chute, its rock-lever, and an eccentric disk mounted upon said lever and faced with soft material, and adapted for rolling contact upon the shaft, substantially as explained.

6. In a grinding mill, the combination with a rotary shaft, of a bed stone, a runner stone carried by said rotary shaft, a horizontal arm adjustably secured to the bed piece of the mill, a vertical spring arm carried by said horizontal arm, a thrust ball-bearing for said rotary shaft carried at the upper end of said vertical arm, a screw for adjusting said thrust bearing and shaft, and a locking nut for said screw, substantially as described.

7. In a grinding mill, the combination with a stationary bed stone, of a rotary shaft, a flexible plate secured to said rotary shaft, a runner stone carried by said flexible plate, bosses formed at intervals on said flexible plate, radial rods mounted in said bosses and the hub of said flexible plate, and weights adjustably mounted on said rods, substantially as described.

8. In a grinding mill, the combination with the grinding agencies, of a rotary shaft upon which one of said grinding agencies is mounted, a casing for said grinding agencies, said casing comprising a stationary lower

half, a removable upper half, and a separable end head, which latter supports the other of said grinding agencies together with a feed hopper and chute, journals on said end head, grooved rollers mounted thereon, suitable ways on which said end head with its supported parts travels, and means for moving the same upon said ways, substantially as described.

9. In a grinding mill, the combination with a rotary shaft, of a runner stone carried thereby, a stationary stone, an inclosing casing for said stones, comprising a stationary lower half, a removable upper half, and a detachable end head provided with supporting rollers, parallel ways upon which said rollers travel, a yoke mounted at the end of said ways, a screw rod carried by said yoke and connected with said end head, and a hand wheel for moving said rod longitudinally.

10. In combination with a runner-stone of a grinding mill, a series of scrapers detachably secured thereto, said scrapers being J shaped, the shorter arm adapted to enter the rear face of the stone, and straddle a band, the longer arm to extend transversely across the periphery of the stone, and operating substantially as explained.

11. In grinding mills, a fixed stone, its inclosing casing, and a runner stone supported upon a rotary shaft, combined with mechanism adapted to advance the shaft endwise to compensate for wear of the stones and consisting of an adjustable plate, a vertical spring bar secured thereto, a non-revoluble journal-box, and a screw which engages the spring-bar and bears against the journal-box, substantially as specified.

12. In a grinding mill, the combination with a rotary shaft, of a runner stone carried thereby, a stationary stone, and an inclosing casing for said stones, said casing comprising a removable end head carrying the bed-stone, a hopper, vibrating feed mechanism, end bearing for rotary shaft and provided with supporting rollers, and a track by which said parts are removable from the runner-stone and the casing, substantially as stated.

13. In a grinding mill, the combination with a rotary shaft, two grinding stones, and feed hopper, of an oscillating feed chute, a bell-crank lever affixed to said chute, a disk mounted upon the free end of the lever, and an eccentric disk attached to the rotary shaft, substantially as described.

In testimony whereof we affix our signatures in presence of two witnesses.

THOMAS J. STURTEVANT.
THOS. L. STURTEVANT.

Witnesses:

H. E. LODGE,
FRANCIS C. STANWOOD.