

April 5, 1966

J. G. FISHER

3,244,314

VENT CAP

Filed July 13, 1964

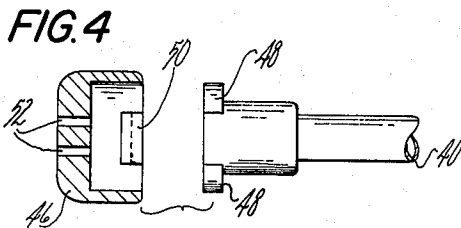
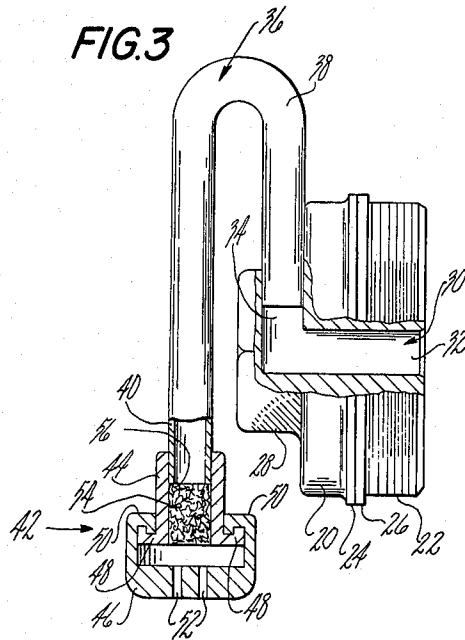
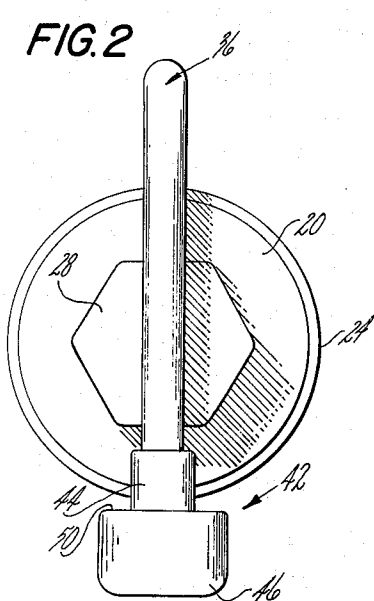
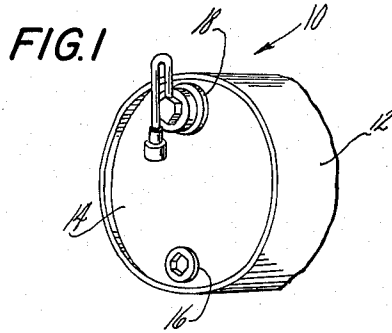

INVENTOR.
JOHN G. FISHER

BY

Mc Connick, Paulding & Huber
ATTORNEYS

1

3,244,314
VENT CAP

John G. Fisher, 20 Meredith St., Springfield, Mass.

Filed July 13, 1964, Ser. No. 382,167

5 Claims. (Cl. 220-44)

This invention relates to and has as its object the provision of an improved vent cap particularly well adapted for use in an end wall of a barrel or other liquid container.

In industrial, commercial and military establishments it is a conventional practice to maintain several barrels of oils, dyes, solvents, etc. in storage with their contents subject to use from time to time. The barrels are conventionally stored on their sides with their end walls substantially vertical and are tapped with small faucets or drains inserted in appropriate openings in the end walls. The end walls of the barrels are normally provided with vent openings and associated plugs or caps. In conventional use, liquid is drawn from the barrels with the vent caps or plugs removed and dust and other foreign matter may enter the barrels with the vent air resulting in contamination of the contents. Moreover, contamination of barrel contents may also result from caps or plugs improperly replaced over vent openings between periods of use.

In accordance with the present invention, the improved vent cap is constructed and arranged to prevent contamination of the contents of a barrel by filtering the air flowing into the barrel during withdrawal of liquid therefrom. The vent cap is not removed from the barrel vent opening during withdrawal of liquid from the barrel and, accordingly, there can be no failure to properly reengage the cap with the vent opening as might result in contamination. After initial tapping of the barrel, the vent cap of the present invention remains in the vent opening until the barrel is empty.

The drawing shows a preferred embodiment of the invention and such embodiment will be described, but it will be understood that various changes may be made from the construction disclosed, and that the drawing and description are not to be construed as defining or limiting the scope of the invention, the claims forming a part of this specification being relied upon for that purpose.

Of the drawing:

FIG. 1 is a fragmentary perspective view showing an end portion of a barrel with the vent cap of the present invention mounted in place thereon;

FIG. 2 is an enlarged end view of the vent cap of the present invention;

FIG. 3 is an enlarged side view of the vent cap partially in section; and

FIG. 4 is an exploded view showing a closure means and a portion of a vent tube forming a part of the vent cap.

Referring particularly to FIG. 1, a conventional barrel is partially shown on its side at 10 with a substantially horizontal side wall 12 and a substantially vertical end wall 14. At a lower portion of the end wall 14 there is provided an opening or plug 16 where the barrel can be tapped for withdrawal of liquid. At an upper portion of the end wall, there is provided a vent opening spaced from the side wall 12 of the barrel and provided with a small flange 18. The opening carries internal threads for the insertion of an externally threaded plug which, in the conventional mode of use mentioned above, is removed for venting the interior of the barrel on withdrawal of liquid.

The vent cap of the present invention is adapted for entry of a threaded body portion in the aforesaid vent opening as shown. Thus, a body portion 20 of the vent

2

cap is provided with threads over a cylindrical portion thereof at 22. The threads extend to a narrow annular flange 24 which has an associated gasket or packing 26. The packing or gasket 26 is preferably formed of a resilient material such as neoprene or nylon. On turning the body portion of the vent cap into the threaded opening of the barrel end wall, the gasket 26 is compressed on engagement with the outer surface of the aforesaid barrel flange 18 to provide for tightening and an air-tight condition of the vent cap in a plurality of selected angular positions of the cap. Thus, the cap may be turned to a closed and air-tight condition at several different angular positions for a purpose to be described.

An outer portion of the body 20 of the vent cap is preferably provided with a projection 28 which may be hexagonal in plan form as shown for engagement with a tightening wrench. Other means of turning the cap may, of course, be employed within the scope of the invention.

A vent opening 30 through the body 20 of the vent cap has inner and outer portions 32, 34. The inner portion 32 extends generally axially while the outer portion 34 communicates therewith and extends generally radially so as to open through the aforesaid projection 28.

A small vent tube 36 is also provided in accordance with the invention and has one end portion thereof in communication with the vent opening 30 and an intermediate portion 38 which is disposed in spaced relationship with the cap body 20 and which projects above the side wall of a barrel on which the cap is mounted. As shown, the tube 36 has an intermediate portion 38 which is bent back upon itself and is generally U-shaped so as to extend upwardly above the side wall 12 of the barrel 10 and thence generally downwardly. The said one end portion of the tube is preferably entered in the portion 34 of the cap vent opening as shown for frictional connection with the cap body. Thus, liquid within the barrel 10 may enter the vent opening 30 and may even enter the tube 36 when the barrel is first tapped and the liquid level is high but the liquid is prevented from flowing through the intermediate portion 38 of the tube which extends above the side wall of the barrel.

The aforementioned gasket 26 and its function in providing for selective tightening of the vent cap can now be more fully appreciated. When the cap is tightened in position in relationship to the barrel 10, it is necessary that the angular position of the cap be such as to provide for the substantially vertical projection of the vent tube 36. Quite obviously, improper tightening of the vent cap with the vent tube displaced substantially from the vertical may result in leakage of liquid outwardly from the barrel through the said tube. The gasket 26 provided for the leak-free angular adjustment of the body 20 as may be required to align the tube 36 with a vertical plane.

Further in accord with the present invention, the tube 36 is provided at its outer or lower end portion 40 with a closure means such as indicated generally at 42. The said closure means preferably comprises an inner part 44 detachably connectible with an outer part 46. As shown, the inner part 44 receives the said outer end portion 40 of the tube in a friction tight fit and has opposing annular flanges 48, 48 at its outer end portion. The flanges 48, 48 extend first radially and then axially inwardly so as to mate with small locking flanges 50, 50 on the outer part 46 of the closure means. The flanges 50, 50 extend radially inwardly from an inner surface of the said outer part 46 and thence axially outwardly. A simple operation of engaging the outer part of the closure means 42 about the inner part and then turning the same through a partial revolution locks the two parts

together for use of the cap. Still further, and with regard particularly to the outer part 46 of the cap, small vent openings 52, 52 provide for the inward flow of air through the closure means, through the tube 36 and through the vent opening 30 in the cap body 20. The said vent openings 52, 52, the tube 36 and the vent opening 30 will be seen to define a continuous vent passageway.

Finally, there is provided in the vent passageway of the cap of the present invention an appropriate filter means. In accordance with the presently preferred practice, the said filter means comprises a small cigarette-type filter 54 disposed within the inner part 44 of the closure means and seated against the outer edge surface 56 of the tube 36. The filter 54 serves to clean the air flowing inwardly through the aforesaid vent passageway whereby wholly to preclude contamination of the liquid within the barrel 10 as aforesaid.

From the foregoing, it will be apparent that the vent cap of the present invention is of desirably simple and yet durable construction. Oil or other liquid within a barrel such as the barrel 10 is prevented from flowing outwardly through the vent passageway comprising the openings 30, 52 and the tube 36. Contamination of the liquid within the barrel is prevented by filtering the vent air entering the barrel and by providing for the continuous engagement of the vent cap in the barrel vent opening. Rain water and the like is prevented from entering the barrel by the particular configuration of the vent cap wherein the openings 52, 52 face downwardly in the closure part 46. Finally, use of the vent cap in a prone barrel has been discussed above but it is to be understood that the cap can be used to advantage in an upright barrel wherein the end wall of the barrel lies in a horizontal plane. The leakage prevention feature of the tube 36 in its projection above the barrel side wall is, of course, unnecessary when the barrel is in an upright attitude but the vent cap of the invention functions otherwise in the manner described. Filtered air is introduced to the barrel as required and yet contamination of the barrel contents is avoided.

I claim:

1. A vent cap adapted for use in association with an opening spaced from the side wall and disposed in a substantially vertical end wall of a barrel or other container, said vent cap comprising a body having a cylindrical portion threaded for engagement with complementary threads associated with the barrel opening, said vent cap having a vent opening therein extending from inner to outer portions thereof, a small generally U-shaped vent tube with one end portion in communication with said vent opening at said outer portion of the vent cap body

and with an intermediate portion disposed in spaced relationship with said cap body and extending above the side wall of the barrel, the other end portion of said tube opening downwardly, a closure means operatively associated with said other end portion of said tube and provided with at least one small vent opening communicating with said vent tube and facing downwardly to avoid the entry of rain water therethrough, and a small filter disposed within said closure means.

2. A vent cap adapted for use in association with an opening spaced from the side wall and disposed in a substantially vertical end wall of a barrel or other container, said vent cap comprising a body having a cylindrical portion threaded for engagement with complementary threads associated with the barrel opening, said vent cap having a vent opening therein extending from inner to outer portions thereof, a small generally U-shaped vent tube with one end portion entered in and frictionally retained in an outer end portion of said vent opening in said vent cap body and with an intermediate portion disposed in spaced relationship with said cap body and extending above the side wall of the barrel, the other end portion of said tube opening downwardly, a closure means operatively associated with said other end portion of said tube and provided with at least one small vent opening communicating with said vent tube and facing downwardly to avoid the entry of rain water therethrough, and a small filter disposed within the vent passageway formed by said vent openings and said vent tube.

3. A vent cap as set forth in claim 2 wherein said closure means comprises detachably connected inner and outer parts, said inner part including an opening for receiving said other end portion of said vent tube.

4. A vent cap as set forth in claim 3 wherein said filter comprises a small cigarette-type filter disposed within said inner and outer parts of said closure means and seated on the edge surface of said other end portion of the vent tube.

5. A vent cap as set forth in claim 4 and including a resilient gasket operatively associated with the threaded cylindrical portion of said cap body to provide for tightening of the vent cap in the barrel opening at a selected angular position of the cap.

References Cited by the Examiner

UNITED STATES PATENTS

1,203,687 11/1916 Bemis.
2,650,673 9/1953 Bering et al. ----- 220-44

50 THERON E. CONDON, *Primary Examiner.*

J. B. MARBERT, *Assistant Examiner.*