

(No Model.)

W. E. SMITH.
SPRING TOOTH HARROW.

No. 522,435.

Patented July 3, 1894.

Fig. 1.

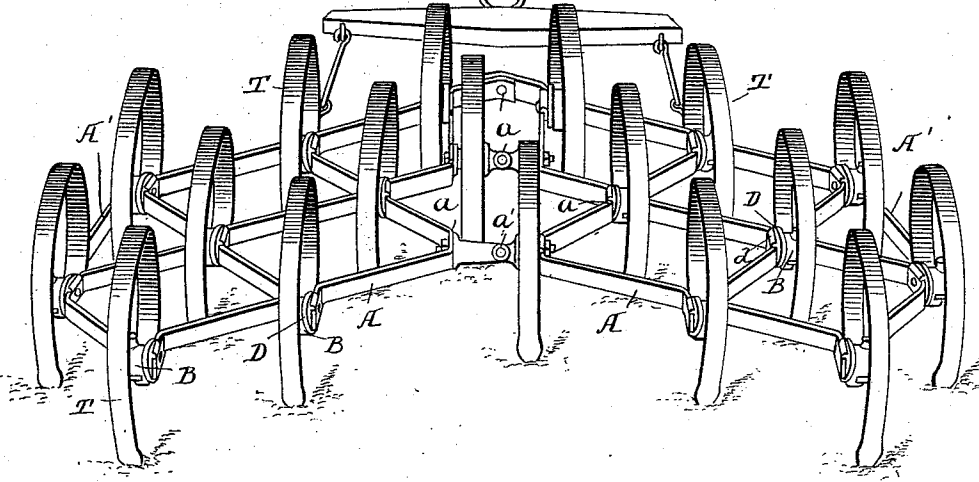

Fig. 2.

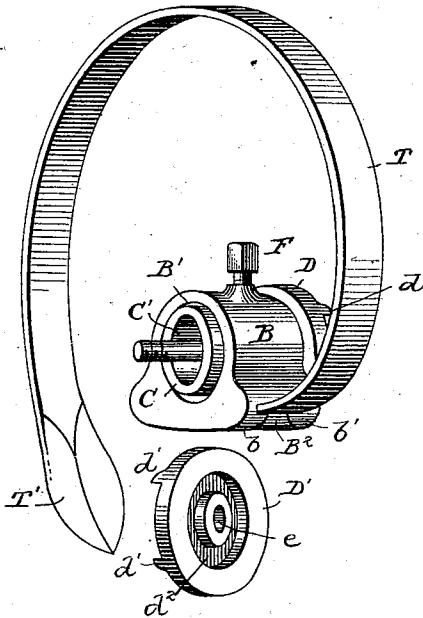
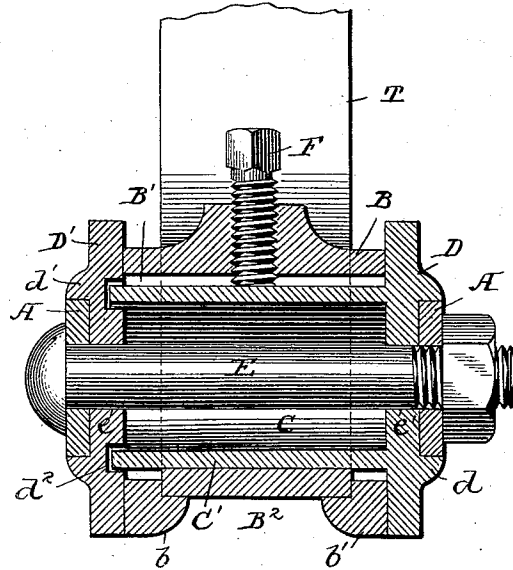

Fig. 3.



Witnesses
Jno. G. Hinkel
A. E. Hansmann

Inventor.
William E. Smith
by Foster Truman
Attorneys

UNITED STATES PATENT OFFICE.

WILLIAM E. SMITH, OF WATKINS, NEW YORK.

SPRING-TOOTH HARROW.

SPECIFICATION forming part of Letters Patent No. 522,435, dated July 3, 1894.

Application filed September 22, 1892. Renewed January 18, 1894. Serial No. 497,332. (No model.)

To all whom it may concern:

Be it known that I, WILLIAM E. SMITH, a citizen of the United States, residing at Watkins, Schuyler county, New York, have invented certain new and useful Improvements in Spring-Tooth Harrows, of which the following is a specification.

My invention relates to spring tooth harrows, and it has for its object to provide means whereby the spring teeth may be adjustably and securely held in position in connection with the frame of the harrow, and to these ends my invention consists in the features of construction, arrangement, and mode of operation substantially as herein set forth.

Referring to the accompanying drawings, Figure 1, is a perspective view of a harrow embodying my invention. Fig. 2, is an enlarged perspective view of one of the harrow teeth, and means for holding it, the parts being detached. Fig. 3, is an enlarged sectional view through the holder and harrow tooth.

I have shown my invention as applied to one form of harrow frame in which the frame is made up of a series of strips or straps A, bent in zig-zag form, and having flat portions *a* by means of which they may be secured together, and in the present instance I have shown the strips or straps held by the same bolts that secure the tooth holder in position. The frame may be of any size, shape or design, and preferably is made of two wings or parts hinged together, as at *a'*, while the outer sides are provided with strengthening strips A'. These strips or straps may be made of wrought iron or other suitable material, and can be forged or otherwise bent in the form desired.

The tooth holder proper consists of a hub or yoke B, which may be made of cast metal or otherwise, and which is provided with a cylindrical opening B', and the under side is provided with lugs or ribs *b, b'* projecting inwardly, and adapted to receive the tooth T, which is shown as being made of spring metal, preferably having a pointed end T'. The hub also has an opening B², through the bottom between the ribs *b, b'* to the cylindrical opening, and the ribs are so arranged that when the tooth is in position, it will extend

slightly into the opening B', as clearly shown in Fig. 3.

Arranged to support the holder and the parts of the frame is a connector C, and this connector consists essentially of a hollow tube C', of a diameter considerably smaller than the opening B' in the hub, and of a length sufficient to extend through the yoke. Mounted on, or connected to this tube is a disk D, and this disk is preferably provided with ribs *d*, on its outer face, the ribs extending parallel across the face and at a distance apart sufficient to receive the frame A. Another disk D', which is preferably separate from the tube, is also provided with ribs *d'*, on its outer face to receive the adjacent portion of the frame, and its inner face is recessed as at *d²* to fit over the end of the tube C', and to allow the disk to be clamped against the face of the hub. These parts may be secured together by any suitable means and I have shown a bolt E, arranged to pass through the opening *e*, in the disk D', through the tube C', and the opening *e'* in the disk D, and through corresponding openings in the parts of the frame A.

It will thus be seen that when the parts are in the position shown in Fig. 3, and the screw is tightened, the hub B is clamped by the disk, and furthermore, the parts of the frame A are also clamped and held in position by the same bolt, so that a single bolt serves not only to secure the parts of the holder and connections together, but also the adjacent parts of the frame of the harrow. In order to secure the tooth in the hub, the tube C is arranged to bear upon the upper face of the tooth, and clamp the tooth between the cylinder and the ribs of the hub, and I have shown a screw F, passing through an opening in the top of the hub, and bearing on the face of the cylinder C, and forcing the cylinder on to the upper face of the tooth, clamping it securely in position. Not only does this secure the tooth in the hub, but also prevents the hub rotating on the cylinder, and adds to the friction of the disk in maintaining the hub in its proper position.

It will be seen that with this device if it is desired to adjust a tooth, it is only necessary

100

to loosen the screw F, when the tooth can be slipped in or out of its socket, and again secured by tightening the screw. Further it will be seen that if the positions of the tooth
 5 and hub are to be adjusted without changing the position of the tooth in the hub, it is only necessary to loosen the bolt E, when the tooth and hub can be adjusted to any desired angle and again secured.

10 All the parts of my device can be cheaply and easily made of strong and durable material, and quickly and easily adjusted for any desired purpose, and the harrow can readily be taken apart, or put together, and the whole
 15 forms a simple and effective device for the purpose specified.

It will be understood that while I have shown the preferred embodiment of my invention, the details of construction may be
 20 varied without departing from the spirit of my invention, and I do not limit myself to the exact details shown.

What I claim is—

1. The combination of the hub and spring
 25 tooth mounted therein, of the cylinder mount-

ed in the hub, and means for pressing the cylinder on to the tooth to secure it in position, substantially as described.

2. The combination with the hub having ribs forming a recess for the reception of the
 30 tooth, and having an opening therethrough, of a cylinder fitting the opening loosely and bearing on the tooth, and means for pressing the cylinder in position, substantially as described.

3. The combination with the hub having a recess for the reception of the tooth, and an opening through it, of a cylinder, the disk having ribs for the reception of the frame,
 35 the bolt for securing the parts together, and
 40 the screw for pressing the cylinder against the face of the tooth, substantially as described.

In testimony whereof I have signed my name to this specification in the presence of
 45 two subscribing witnesses.

WILLIAM E. SMITH.

Witnesses:

JNO. C. COMFORT,
 H. F. HOLLER.