



US006382091B1

(12) **United States Patent**  
**Speranza**

(10) **Patent No.:** **US 6,382,091 B1**  
(45) **Date of Patent:** **May 7, 2002**

(54) **METHOD OF CODING A HIGH-SPEED OBJECT**

(76) Inventor: **Bernard E. Speranza**, 9216 White Oak Ave., Munster, IN (US) 46321

(\*) Notice: Subject to any disclaimer, the term of this patent is extended or adjusted under 35 U.S.C. 154(b) by 0 days.

(21) Appl. No.: **09/727,564**

(22) Filed: **Dec. 1, 2000**

(51) **Int. Cl.<sup>7</sup>** ..... **B41F 17/14; B41F 17/20**

(52) **U.S. Cl.** ..... **101/35; 101/42; 101/41; 101/483; 101/485**

(58) **Field of Search** ..... **101/18, 21, 42, 101/43, 35, 36, 37, 483, 485**

(56) **References Cited**

**U.S. PATENT DOCUMENTS**

3,864,691 A \* 2/1975 Schroeder ..... 346/74.2  
4,506,999 A 3/1985 Robertson ..... 400/121

4,808,018 A 2/1989 Roberston et al. .... 400/121  
4,883,291 A 11/1989 Robertson ..... 283/117  
4,985,715 A 1/1991 Cyphert et al. .... 346/140 R  
5,015,106 A 5/1991 Robertson et al. .... 400/121  
5,074,244 A \* 12/1991 Byers ..... 118/669  
5,144,330 A \* 9/1992 Bennet ..... 347/2  
5,199,109 A 3/1993 Baker ..... 346/1.1

\* cited by examiner

*Primary Examiner*—Daniel J. Colilla

(74) *Attorney, Agent, or Firm*—Wallenstein & Wagner, Ltd.

(57) **ABSTRACT**

A method of coding a high-speed object having a lateral travel path with a multi-digit production series number is disclosed. A first marking member and a second marking member are provided, with the second marking member positioned vertically adjacent the first marking member. A plurality of marking locations are defined and a group of marks are applied along each of the plurality of marking locations. The quantity of marks in each group represents a respective digit of the multi-digit series number.

**10 Claims, 2 Drawing Sheets**

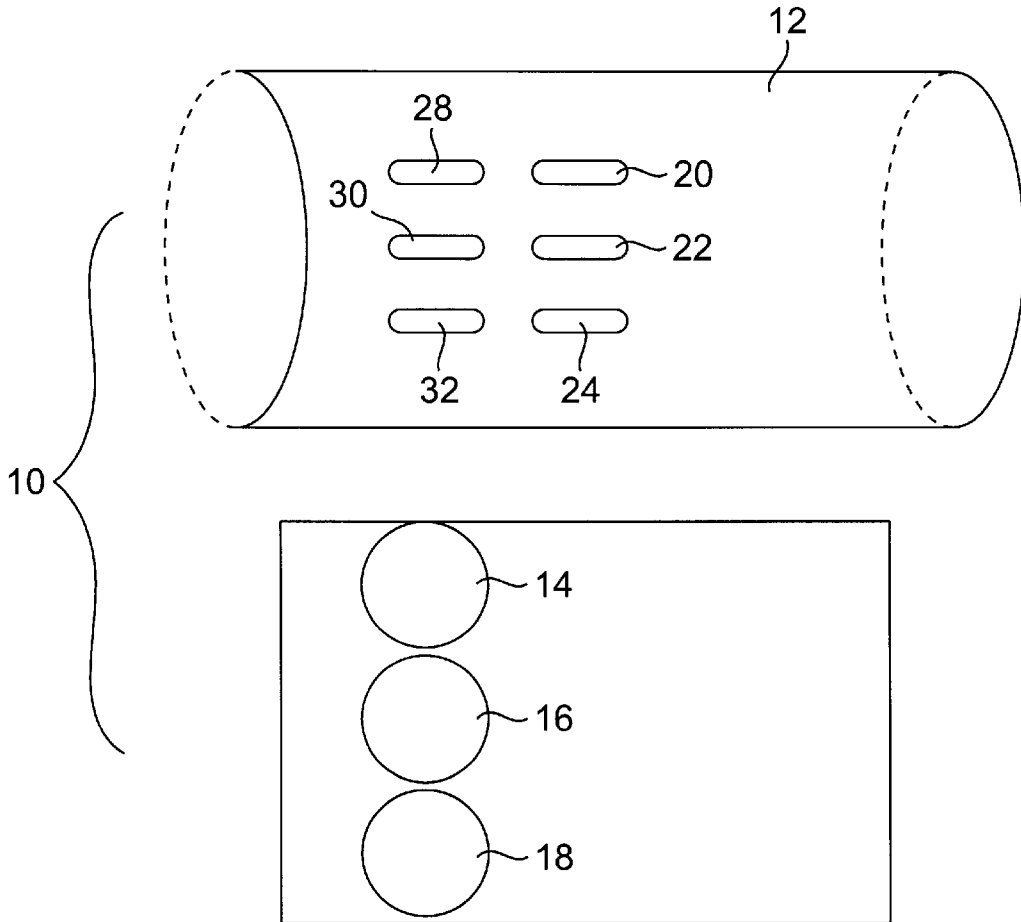

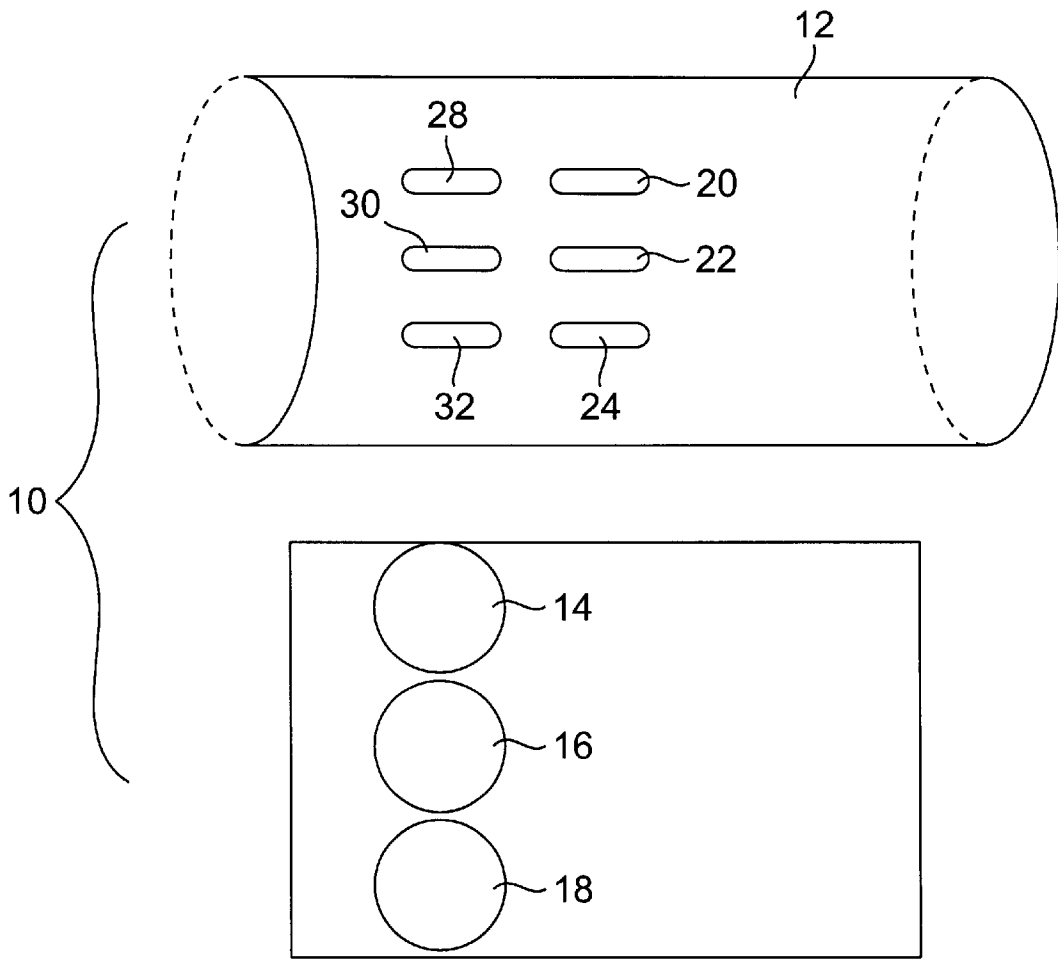

FIG. 1

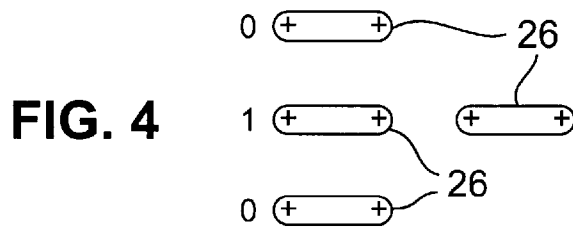

FIG. 4

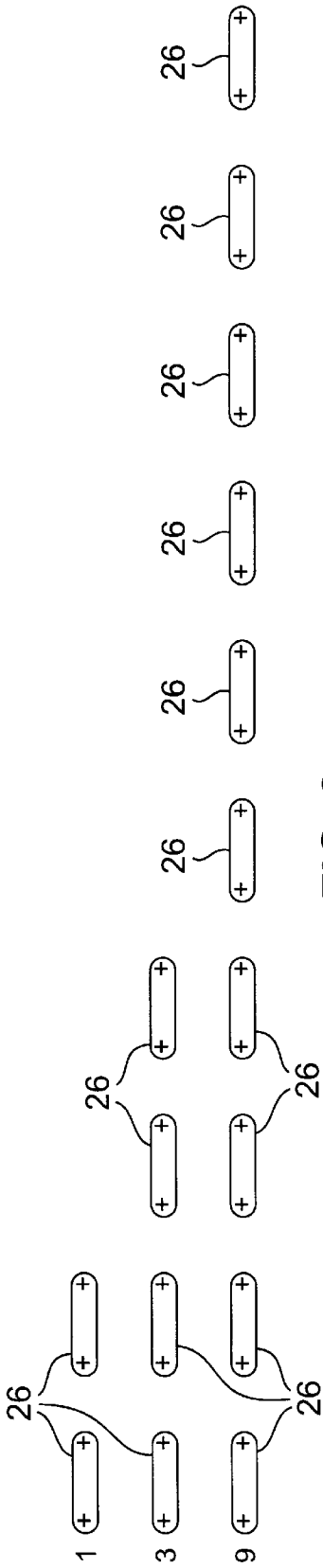

FIG. 2

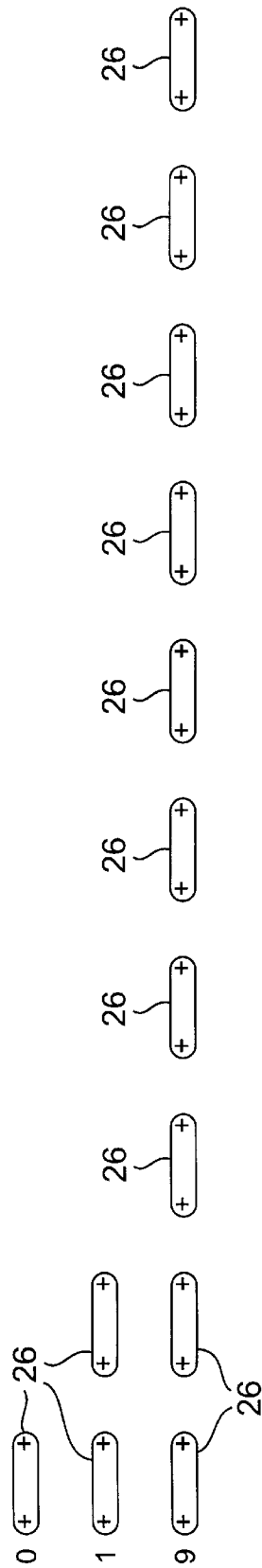

FIG. 3

## METHOD OF CODING A HIGH-SPEED OBJECT

### TECHNICAL FIELD

The invention relates to a method of coding high-speed objects and, more particularly, to a method for coding a high-speed object, such as a pipe, having a lateral travel path with a multi-digit production series number.

### BACKGROUND OF THE INVENTION

Requirements have developed in many industries to devise techniques for tracing the history of a product through the course of a multi-stage production process. Specifically, manufacturers desire to track the location of an object within a production series. This is sometimes referred to as the "in process number." Pipes, or other products such as structural shapes, in a production series can easily be separated and identified for applying a complete identification number. However, the chronological order of each pipe within the series may be disturbed as the pipes get mixed on the cooling conveyors.

Prior art marking technology involves the formation of characters or symbols in dot matrix fashion using discrete jets of marker fluid or ink. This marker ink is expressed from select ones of a linear array of nozzles in conjunction with atomizing air to form dots at the workpiece to be marked. However, marking of fast-moving pipes in a production line with spray paint dots may be difficult. Oftentimes, the pipe moves so quickly that the paint spray dots are distorted which, in turn, distorts the alpha numeric symbols they are attempting to represent. For example, at speeds above 600 feet per minute, the shape of the ink jet spray becomes a rectangle with rounded short ends oval. Accordingly, marking pipe in a production line utilizing prior art ink or paint jet spray is unsuccessful since the marks are not readable.

Various systems have been proposed for marking multi-character messages on the surface of solid materials, such as disclosed in U.S. Pat. Nos. 4,506,999; 4,808,018; 4,883,291; 4,985,715; 5,015,106; and 5,119,109. However, these systems are relatively complex.

The present invention is provided to solve these and other problems.

### SUMMARY OF THE INVENTION

It is an object of the present invention to provide a method of coding a high-speed object, such as a pipe, having a lateral travel path with a multi-digit production series number. Preferably, the pipe is moving at a speed of at least 600 feet per minute.

In accordance with the invention, a first marking member and a second marking member are provided. The second marking member is positioned vertically adjacent the first marking member. In one aspect of the invention, a third marking is provided vertically adjacent the second marking member. The second marking member is positioned between the first marking member and the third marking member. Preferably, the marking members are nozzles.

A plurality of peripherally-spaced, axially-directed marking locations are defined and a group of generally elongated marks are applied along each of the plurality of marking locations. The quantity of marks in each group represents a respective digit of the multi-digit production series number. The marks are read and assigned the respective digit of the multi-digit series number.

It is contemplated that a plurality of test marking locations are defined prior to defining the plurality of marking loca-

tions. A generally elongated mark is applied along each of the plurality of test marking locations before applying a group of marks along each of the plurality of marking locations.

It is also contemplated that a plurality of test marking locations are defined after defining the plurality of marking locations. A generally elongated mark is applied along each of the plurality of test marking locations after applying a group of marks along each of the plurality of marking locations.

It is further contemplated that the group of marks is visually-readable by a human observer.

It is still further contemplated that the group of marks is machine-readable.

Other features and advantages of the invention will be apparent from the following specification taken in conjunction with the following drawings.

### BRIEF DESCRIPTION OF THE DRAWINGS

FIG. 1 is an exploded front view of the components of a system for coding a high-speed object according to a preferred aspect of the invention;

FIG. 2 is a front view of the pipe of FIG. 1 after coding, showing the number 139;

FIG. 3 is a front view of the pipe of FIG. 1 after coding, showing the number 019; and

FIG. 4 is a front view of the pipe of FIG. 1 after coding, showing the number 010.

### DETAILED DESCRIPTION OF THE PREFERRED EMBODIMENT

While this invention is susceptible of embodiments in many different forms, there is shown in the drawings and will herein be described in detail a preferred embodiment of the invention with the understanding that the present disclosure is to be considered as an exemplification of the principles of the invention and is not intended to limit the broad aspect of the invention to the embodiment illustrated.

A system, generally designated **10**, for coding a high-speed object, such as pipe **12**, having a lateral travel path with a multi-digit production series number is illustrated in FIG. 1.

System **10** has a first marking member **14** and a second marking member **16**. Preferably, first marking member **14** and second marking member **16** are paint nozzles or jets. Second marking member **16** is positioned vertically adjacent first marking member **14**. Preferably, system **10** has a third marking member **18** positioned vertically adjacent second marking member **16**. The second marking member **16** is positioned between first marking member **14** and third marking member **18** (see FIG. 1). The marking members may be paint nozzles used for coding high-speed objects, such as the nozzle distributed by Magnemag Corporation of Copenhagen, Denmark.

In one aspect of the invention, pipe **12** travels at a speed in excess of 600 feet per minute. Moreover, the surface temperature of pipe **12** may exceed 1500 degrees Fahrenheit. The marking members project fluid, such as ink or paint, capable of adhering to pipes traveling in excess of 600 feet per minute and having a surface temperature in excess of 1500 degrees Fahrenheit. Inks, such as high alkaline inks formed with ceramic particle suspensions, are utilized for high temperature environments.

A plurality of peripherally-spaced, axially-directed marking locations are shown in FIG. 1. First marking location **20**,

3

second marking location **22** and third marking location **24** are utilized to code pipe **12** with a multi-digit production series number, ranging from 0 to 999. It is contemplated that only one marking location is utilized for coding pipe **12** with a single digit production series number, ranging from 0 to 9. It is likewise contemplated that only two marking locations are utilized for coding pipe **12** with a multi-digit production series number, ranging from 0 to 99. If the production series desired to identify 10,000 units, four marking locations are required, 100,000 units, five marking locations, etc.

As shown in FIGS. **2-4**, marking members **14, 16** and **18** apply a group of generally elongated marks **26** along each of marking locations **20, 22** and **24**. The quantity of marks in each group represents a respective digit of the multi-digit production series number. For example, the number 139 is shown in FIG. **2**. First marking member **14** fires one burst of ink at first marking location **20** resulting in one mark **26** along first marking location **20**. This one mark indicates the number 100. Second marking member **16** fires three bursts of ink at second marking location **22** resulting in three marks **26** along second marking location **22**. These three marks indicate the number 30. Third marking member **18** fires nine bursts of ink at third marking location **24** resulting in nine marks **26** along third marking location **24**. These nine marks indicate the number 9. The code is then read from top to bottom as 139. Similar to FIG. **2**, FIG. **3** illustrates the number 019 and FIG. **4** illustrates the number 010.

In another aspect of the invention, and as shown in FIG. **1**, system **10** further has a plurality of test marking locations. First test marking location **28**, second test marking location **30** and third test marking location **32** are provided before marking locations **20, 22** and **24**, respectively. Marking members **14, 16** and **18** apply a test mark one unit before the beginning of the code to illustrate that the marking members are operating properly. This is especially important when one of the three numbers in the multi-digit production series number is a zero (0). To eliminate any uncertainty whether there are intentionally no marks at a specific marking location, one mark **26** is applied at each of test marking locations **28, 30** and **32**. Likewise, three additional test marking locations may be provided after marking locations **20, 22** and **24**, respectively, to indicate the end of the code.

In a further aspect of the invention, the group of marks **26** is visually-readable by a human observer. Moreover, the group of marks **26** is machine-readable.

While the specific embodiment has been illustrated and described, numerous modifications come to mind without significantly departing from the spirit of the invention, and the scope of protection is only limited by the scope of the accompanying Claims.

What is claimed is:

1. A method of coding a high-speed object having a lateral travel path with a multi-digit production series number comprising the steps of:

4

providing a first marking member and a second making member;

positioning the first marking member;

positioning the second marking member proximate the first marking member;

defining a plurality of marking locations;

applying a group of generally elongated marks along each of the plurality of marking locations, a quantity of marks in each group representing a respective digit of the multi-digit series number;

reading the quantity of marks in the group of marks; and, assigning the respective digit of the multi-digit series number to the quantity of marks in the group of marks.

2. The method of claim **1** further comprising the steps of: providing a third marking member; and,

positioning the third marking member proximate the second marking member, with the second marking member positioned between the first marking member and the third marking member.

3. The method of claim **1** further comprising the steps of: defining a plurality of first test marking locations before the step of defining the plurality of marking locations; and,

applying a generally elongated mark along each of the plurality of first test marking locations before applying the group of generally elongated marks along each of the plurality of marking locations.

4. The method of claim **3** further comprising the steps of: defining a plurality of second test marking locations after the step of defining the plurality of peripherally-spaced, axially-directed marking locations; and,

applying a generally elongated mark along each of the plurality of second test marking locations after applying the group of generally elongated marks along each of the plurality of marking locations.

5. The method of claim **1** wherein the group of marks is visually-readable by a human observer.

6. The method of claim **1** wherein the group of marks is machine-readable.

7. The method of claim **1** wherein the high-speed object is a pipe.

8. The method of claim **7** wherein the pipe is moving at a speed of at least 600 feet per minute.

9. The method of claim **1** wherein the first and second marking members are nozzles.

10. The method of claim **2** wherein the third marking member is a nozzle.

\* \* \* \* \*