

(19) World Intellectual Property Organization
International Bureau



(43) International Publication Date
15 April 2004 (15.04.2004)

PCT

(10) International Publication Number
WO 2004/032533 A1

- (51) International Patent Classification⁷: **H04Q 1/14**
- (21) International Application Number: PCT/GB2003/004027
- (22) International Filing Date: 17 September 2003 (17.09.2003)
- (25) Filing Language: English
- (26) Publication Language: English
- (30) Priority Data:

200202265	3 October 2002 (03.10.2002)	ES
200301379	11 June 2003 (11.06.2003)	ES
- (71) Applicant (for AE, AG, AL, AM, AT, AU, AZ, BA, BB, BE, BG, BR, BY, BZ, CA, CH, CN, CO, CR, CU, CY, CZ, DE, DK, DM, DZ, EC, EE, ES, FI, FR, GB, GD, GE, GH, GM, GR, HR, HU, ID, IE, IL, IN, IS, IT, JP, KE, KG, KP, KR, KZ, LC, LK, LR, LS, LT, LU, LV, MA, MD, MG, MK, MN, MW, MX, MZ, NI, NO, NZ, OM, PG, PH, PL, PT, RO, RU, SC, SD, SE, SG, SK, SL, SY, TJ, TM, TN, TR, TT, TZ, UA, UG, UZ, VC, VN, YU, ZA, ZM, ZW only): **TYCO ELECTRONICS RAYCHEM SA** [ES/ES]; Ctra. Antigua de Francia, 28108 Alcobendas Madrid (ES).
- (72) Inventor; and
- (75) Inventor/Applicant (for US only): **ARIAS, Juan, Tomas** [ES/ES]; Calle Valencia no. 51, 28100 Alcobendas Madrid (ES).
- (74) Agent: **JAY, Anthony, William**; Tyco Electronics UK Ltd, European Patent Department, Faraday Road, Dorcan, Swindon, Wiltshire SN3 5HH (GB).
- (81) Designated States (national): AE, AG, AL, AM, AT, AU, AZ, BA, BB, BG, BR, BY, BZ, CA, CH, CN, CO, CR, CU, CZ, DE, DK, DM, DZ, EC, EE, ES, FI, GB, GD, GE, GH, GM, HR, HU, ID, IL, IN, IS, JP, KE, KG, KP, KR, KZ, LC, LK, LR, LS, LT, LU, LV, MA, MD, MG, MK, MN, MW, MX, MZ, NI, NO, NZ, OM, PG, PH, PL, PT, RO, RU, SC, SD, SE, SG, SK, SL, SY, TJ, TM, TN, TR, TT, TZ, UA, UG, US, UZ, VC, VN, YU, ZA, ZM, ZW.
- (84) Designated States (regional): Eurasian patent (AM, AZ, BY, KG, KZ, MD, RU, TJ, TM), European patent (AT, BE, BG, CH, CY, CZ, DE, DK, EE, ES, FI, FR, GB, GR, HU, IE, IT, LU, MC, NL, PT, RO, SE, SI, SK, TR).

[Continued on next page]

(54) Title: FILTER SYSTEMS FOR BROADBAND TELECOMMUNICATION FACILITIES

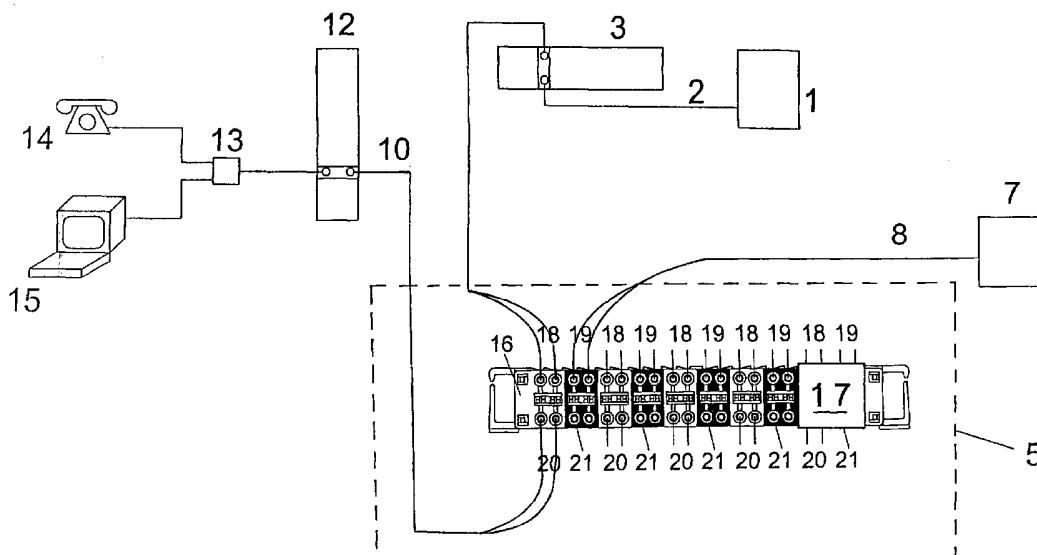

(57) Abstract: Broadband telecommunications facilities wherein the filters or splitters (17) that serve for the combination or segregation of the voice and data signals are arranged in a form separate from the DSLAM (7), being connected externally to the connection block of the intermediate distribution frame (5), and preferably being individual filters (17), which permits no increase in the space used in the distribution frame, easy replacement and maintenance, and due to the arrangement of the contact pairs on the connection block of the intermediate distribution frame maximum use is obtained of the same, being grouped together in groups of two pairs (18-21), wherein the half-pair (21) that remains free is used either as a point of grounding or as a contact for metallic access.

WO 2004/032533 A1



Declaration under Rule 4.17:

- *of inventorship (Rule 4.17(iv)) for US only*

Published:

- *with international search report*
- *before the expiration of the time limit for amending the claims and to be republished in the event of receipt of amendments*

For two-letter codes and other abbreviations, refer to the "Guidance Notes on Codes and Abbreviations" appearing at the beginning of each regular issue of the PCT Gazette.

FILTER SYSTEMS FOR BROADBAND TELECOMMUNICATION FACILITIES

The present invention relates to electric filter systems for broadband telecommunication facilities.

5

To provide a high-speed data transmission service, for example over ADSL (asynchronous digital subscriber line) or in general xDSL systems, it is necessary at different stages to combine and to segregate the voice signal, sent by the switching exchange, and the high-speed xDSL data signal, provided by the digital subscriber line access multiplexer (DSLAM). Such combination and segregation of the voice and data signals is effected by means of a filter (sometimes referred to as a splitter), that adds or segregates the signals on their way to or from the subscriber.

The filter serving to combine or segregate the voice and high-speed data signals is often installed jointly with the DSLAM. Given the high price of the combined DSLAM and filter equipment and the double wiring that it is necessary to run between the DSLAM and the intermediate distribution frame, some operators have opted for the separate purchase of the different components, installing filters and DSLAM in different cubicles. In general cards are used which carry multiple filters, that is for several lines or accesses. These cards have the drawback that when a fault occurs in one of the lines it is necessary to replace the entire card, which signifies a high maintenance cost and disrupts the operation of all the lines on that card.

It is an objective of the present invention to provide a more convenient connection architecture or installation for broadband connections, wherein the filters are installed separately from the DSLAM, but not in separate cubicles as in the known systems.

According to the present invention, the filters are installed on the actual intermediate distribution frame, from which the combined voice and data signals pass to and from the vertical connection block. The terms intermediate distribution frame and vertical connection block are well understood by those familiar with this field of telecommunications technology. Preferably, an individual filter is provided for use by each respective individual

30

- 2 -

line or access, which facilitates and reduces the cost of the maintenance, and does not significantly increase the space occupied in the intermediate distribution frame. It is additionally preferred that the constructional characteristics of the filters, as well as of the connection blocks of the intermediate distribution frame, be improved to allow a better use of the space, and to offer a point of manual access. It is furthermore preferred that each of the individual filters carries its own means of protection against over-voltages or over-currents.

10 The installation with electric filters for broadband connections according to the present invention is thus seen as advantageous over the previously known state of the art described in German Utility Model DE-U-20104605, wherein the installation consists of a connection block that has an upper cover and another lower one both designed for the guidance of the cables, presenting frontally two rows of contact pairs of 10 pairs per row. On the inside of the assembly is arranged a filter card carrying all of the filters, in total four, for the four lines that can be connected. The connection block has a series of contact pairs thereon distributed in two rows of 10 contact pairs per row, some of said pairs being employed for the connection to ground. It offers two contact pairs per line to which the combined signal is connected.

20

The installation of DE-U-20104605 presents several drawbacks. Its filter card is inside the connection block, so that in the event of a line fault requiring replacement of the filter, it is inconveniently necessary to open the connection block to gain access to the card. Also, the fact that this single card carries the filters of several lines means that all of the good filters must be replaced at the same time as the faulty filter. Moreover the filters of DE-U-20104605 have no means of protection against over-voltages and over-currents. A further defect of the configuration described in DE-U-20104605 is that its connection block does not allow optimum use of space, since the 10 contact pairs provided can connect a total of only four lines.

30

The configuration now proposed according to the present invention is intended to address some or all of the above disadvantages. The facility according to the present

- 3 -

invention accordingly may be arranged to allow a connection block on the intermediate distribution frame to connect a total of 5 lines; and/or to leave one or more of the pairs free to serve as a contact for metallic access or as manual access to take said signal to the test desk; and/or to allow the filters on the connection block of the intermediate distribution frame to be replaced individually; and/or to provide the individual filters with means of protection against over-voltages and over-currents.

Moreover, the configuration of the wiring of the connection blocks in the intermediate distribution frames according to preferred aspects of the present invention may be arranged to allow an optimisation of the contact pairs, and to leave a half-pair of free contacts per line, to which can be allocated different uses, such as serving for grounding or serving as contact for metallic access and/or connection to a test desk. The half-pair of contacts that is free can be wired to a test desk with the object of enabling automatic supervision of the state of the lines. In further preferred embodiments of the invention, the filters themselves may have some test points that allow access in a manual way to any one of the three signals, voice, data, or combined voice and data, in addition to the possible use of the free pairs.

The distribution of the contact pairs on the connection block is preferably such that, in each two pairs, two half-pairs are arranged in an upper row and the other two half-pairs on the lower row and in correspondence, one of the upper half-pairs is used for the voice signal and the other for the high-speed xDSL data signal, while one of the lower half-pairs is used for the combined voice/data signal and the other is the aforementioned free half-pair, to which different uses can be allocated.

This distribution of the use of the contact pairs on the connection block of the intermediate distribution frame achieves maximum benefit from said block. When there is an odd number of contact pairs on the connection block, it may advantageously be supplemented with an adjoining connection block having the same odd number of pairs, each pair co-operating with that immediately opposite in the adjoining connection block.

Specific embodiments of the present invention will now be described by way of

- 4 -

illustration and not restrictively, with reference to the accompanying drawings, wherein:

Figure 1 shows a conventional "Prior Art" installation for xDSL networks,

Figure 2 shows a connection block and filter for the present invention,

Figure 3 shows the configuration presented by the connection block of the
5 intermediate distribution frame,

Figure 4 shows the configuration of the wiring for broadband networks with the
filters which are the subject of the invention,

Figure 5 shows a representation of a possible multi-filter module, and

Figure 6 shows a representation in which, by means of a metal access block, there is
10 access to the voice, data and combined signals, and the possible use of the free pair, for
subsequent automatic checking of the latter.

In the known facility shown in figure 1, it is observed how from the switching
exchange (1) the voice signal (2) is furnished, which reaches the horizontal connection block
15 (3) and continues to the intermediate distribution frame (5), by means of a voice jumper (4),
continuing later, by means of a cable (6) until arriving at the filter (9) which serves to
combine or segregate the voice signal (2) and the high-speed xDSL signal (8) provided by
the digital subscriber line access multiplexer (DSLAM) (7), from a network, the combined
signal (10) being obtained which is taken once again to the intermediate distribution frame
20 (5), that then continues to the vertical connection block (12), by means of a jumper (11).
From said vertical connection block (12) the combined signal passes through a filter (13)
wherein the voice signal is segregated from the high-speed xDSL signal, terminating either
in the telephone set (14) or in the computer (15). It is observed that the filter (9), forms an
assembly, remote from the intermediate distribution frame (5).

25

Now, according to the present invention, and with the objective of achieving an
installation in which the filter (9) is installed separately from the DSLAM (7) and in an
individual manner, and wherein the drawbacks of previously known arrangements are
addressed, filters and a wiring configuration of the connection blocks on the intermediate
30 distribution frame have been developed as shown in figures 2 and 3.

In figure 2 a filter (17) is shown of individual use for each of the lines, which is

- 5 -

mounted in a form external to the connection block (16) of the intermediate distribution frame, and which has a series of contacts (17.1) arranged so that they fit in the openings of the pairs corresponding to the voice signal, the combined voice plus data signal, the data signal and the possible use of the free pairs. Said filters have on their inside, the means
5 necessary for their protection against over-voltages and over-currents.

In figure 3, the arrangement is shown of the contact pairs on the connection block (16) of the intermediate distribution frame (5), with the object of achieving maximum benefit from the pairs of said connection block (16). The pairs are arranged in two rows each
10 of ten half-pairs of contacts, using two half-pairs of the upper row and the two facing half-pairs of the lower row for a same line. Observe thus that the half-pairs (18) and (19) are used respectively for the voice signal and the high-speed xDSL data signal. On the lower part and arranged opposite, the half-pair (20) is used for the combined voice plus data signal, while the half-pair (21) is free for diverse uses, like for example serving as a point for grounding,
15 or as a point of metallic access, from where the signal can be taken to a test desk with the object of verifying the state of the lines in an automatic way.

Figure 4 shows the configuration of the wiring in which the filter or splitter (9) is fitted separately from the DSLAM (7), the filter or splitter (9) being directly connected on
20 the strip (16). Once again, it can be seen that the strip (16) is fitted in the intermediate distributor (5), the latter having a series of strips (16) which have one or more sets of four pairs of contacts, wherein each set has one free pair (21), one pair for the cables of the voice input signal (18), another for the cables of the xDSL data input signal (19), and another for the cables of the combined output signal.

25

Moreover, the filters (17) include some for testing (17.2) where in a manual way access is available to any of the three signals, voice, data or combined voice and data signal and the possible use of the free pair.

30 With the object of being able to use the free half-pair as metallic access leading to the test desk, it is necessary for the connection block to have the contacts in a certain way, in brief the contacts of the voice signals and the combined signal should be normally closed

- 6 -

while the contacts of the data signal should be normally open, all this with the objective of preventing any short circuit in the extraction of the filters. This configuration allows optimum use of all the pairs that there are in the connection block (16) and in the event that the number of pairs is odd, it allows each half-pair to be grouped with the corresponding half-pair of the adjoining connection block.

Finally it is pointed out that although a description has been made based on individual filters, the same configuration and disposition is also achieved with multi-filter modules, that is with equipment that groups the filters corresponding to several lines, as can be seen in figure 5, in which the multi-filter unit (22) has a series of contacts (22.1) and some test points (22.2), which make it possible to access manually any of the three signals, i.e. voice, data or combined voice or data signal, and the possible use of the free pair.

Figure 6 shows how, by means of a metal access block (23), it is possible to obtain the voice, data and combined signals, as well as the possible use of the free pair, thus making it possible to transmit these signals to a test plate where they are checked automatically. The contacts (24) of the metal access block are introduced into the test points (17.2) with which the filters (17) are provided. There can also be seen the contacts (17.1) of the filters (17) which are connected to the strips (16).

The present invention includes further improvements in the aforementioned facilities with electric filters for broadband connections, the filters designed for these facilities, as well as the connection blocks, also specially designed, to connect the filters. An object of these further improvements of the invention is to permit the use of pairs in adjoining connection blocks, instead of pairs on the same connection block, maintaining the functionality of the facilities, but considerably facilitating the wiring of the connection blocks, the voice (POTS) remaining connected to the line when the filter is removed.

In the systems hereinbefore described, amongst other characteristics, it is designed that the distribution of the contact pairs on the connection block of the intermediate distribution frame is in two rows, using two pairs of the upper row and the two opposite pairs of the lower row for the same line, so that the first two are used for the incoming voice signal and the incoming high-speed xDSL data signal respectively, whilst from the other two, one is used for the outgoing combined voice plus data signal and the other remains free

for various uses, such as, for example grounding, or as point of metallic access from where the signal can be taken to a test desk with the object of verifying the state of the lines in an automatic way. This structure, although successfully reducing costs by separating the multiplexer or DSLAM from the filters, has, however, certain difficulties in the wiring, as
5 this has to be done alternately, i.e. alternate contact pairs of one type or the other throughout a connection block, wiring which would be undoubtedly made easier if all the pairs of each line of the connection block were of the same type.

The further improvements now proposed consist of using parallel connection blocks
10 on the intermediate distribution frame, grouped in pairs, so that, within a certain pair of connection blocks, on one of them, the incoming voice signal of the corresponding lines is established on one of the alignments of the contact pairs, and the outgoing combined voice plus data signal of each one of the lines is established on the other alignment, whilst on the second connection block, and opposite the first one, the incoming high-speed xDSL data
15 signal is established on the contact pairs of one of its alignments, the contact pairs of its second alignment finally remaining free for grounding, as a point of metallic access or for any other auxiliary application. This means that the pins of each filter, instead of being positioned in a coplanar form, can have a parallel arrangement, at a distance coinciding with that between connection blocks, in the mounting thereof on the intermediate distribution
20 frame.

A preferred embodiment of this arrangement will now be described by way of example, with reference to the accompanying drawings wherein:

Figure 7 shows, in schematic front elevation, the connection blocks according to the
25 present further improvements of the invention, wherein one of the individual filters, corresponding to a line, is implanted;

Figure 8 shows in perspective one of the individual filters to be implanted in any of the lines established in the pair of connection blocks of figure 7; and

Figure 9 shows in schematic perspective an intermediate distribution frame with its
30 connection blocks and one of its filters.

In the light of said figures, we can observe how the connection blocks (1) that form part of the intermediate distribution frame (2), are arranged parallel to each other and grouped in pairs, as is shown in figure 7. This allows that both connection blocks (1-1')
35 belonging to the same pair are functionally integrated, establishing, on each one of them, the first alignment of contact pairs (5), (5'), (5''), ... (5ⁿ), used, for example, for the incoming voice signal of the respective lines, and another longitudinal alignment of contact pairs (6), (6'), (6'')...(6ⁿ), used, for example, for the outgoing combined voice plus data signal. At the

- 8 -

same time, on the second connection block (1'), a first alignment of contact pairs (3), (3'), (3'') ... (3ⁿ) is established, used, for example, for the incoming high-speed xDSL data signal, and finally, another alignment of contact pairs (4), (4'), (4'')...(4ⁿ) can remain free, acting as grounding or point of metallic access from where the signal can be taken to a test desk with the purpose of verifying the state of the lines in an automatic way. This means, as stated above, that the connections in the contact pairs (5) are all identical, corresponding to the different lines, as occurs with the contact pairs (6), with the contact pairs (3) and with the contact pairs (4), with no other determining factor than that of the lines being independent, which considerably facilitates the wiring. In accordance with this arrangement for the connection blocks (1-1'), each filter (7) can simultaneously be mounted on two parallel connection blocks (1-1'), as is particularly observed in figure 8, for which purpose the pins (8) of the filter, each one equipped with a pair of terminals (9) in the example in figure 8 or with 3 terminals in the example in figure 9, are arranged parallel, so that one of them is plugged in between the contacts (5) and (6) of one of the connection blocks (1') and the other between the contact pairs (3) and (4) of the other connection block (1), as is also observed in figure 9.

It is not considered necessary to expand this description further for any person skilled in the matter to understand the scope of the invention and the advantages that are derived therefrom. The materials, form, size and arrangement of the structural elements are capable of variation provided they do not alter the essential nature of the invention.

CLAIMS

1. Facilities with electric filters for broadband connections, wherein the voice signal (2), which is obtained from the switching system (1), reaches the horizontal connection block (3), from which there extends a voice jumper (4), which extends to a connection block (16) on the intermediate distribution frame (5), where the voice signal is combined with a separately-generated data signal arriving on a data signal line, and from which intermediate distribution frame the combined signal is transmitted by means of a jumper (11) to the vertical connection block (12) and from there to a filter (13) which transmits the appropriate part of the signal either to the telephone (14) or to the computer (15) of the user, characterised in that the pairs of contacts (18,19,20,21) of the input and output wiring, which is connected to the connection block (16) of the intermediate distribution frame (5) in use, have removably connected between at least some of the said pairs in use filter devices (17,22) at least partly external to the connection block.
2. Facilities according to claim 1, characterised in that individual filters are provided for at least some, preferably for each, of the lines.
3. Facilities according to claim 1 or 2, characterised in that the connection block (16) of the intermediate distribution frame has for each four contact half-pairs one free half-pair, the remaining ones being for the voice signal, the high-speed xDSL data signal, and for the combined voice/data signal.
4. Facilities according to claim 3, characterised in that said free half-pair is used as a point for grounding.
5. Facilities according to claim 3, characterised in that said free half-pair is used as a point of metallic access to obtain said signal and to lead it to a test desk and to perform the verification of the state of the lines in an automatic way.
6. Facilities according to claim 1, characterised in that in a same filter module, several filters corresponding to different lines are grouped together.

7. Facilities according to any preceding claim, characterised in that the connection block (16) has an odd number of contact pairs and is positioned adjacent to a similar connection block and each contact pair of one of the blocks is used in conjunction with the corresponding pair of the other block.

8. Filter unit for installation in facilities according to any preceding claim, characterised in that the filter unit is formed to project externally from the connection block (16) of the intermediate distribution frame (5), and has a series of contacts (17.1) facing the openings of the contacts of the connector half-pairs for the voice signal, the combined voice and data signal, the data signal, and the possible use of the free half-pair, the filter unit preferably also including means of protection against over-voltages and over-currents.

9. Filter unit according to claim 8, characterised in that in a same card the filters of different lines are grouped together.

10. Filter unit according to claim 8, characterised in that the filters (17), have a test jumper (17.2) which allows access in a manual way to the voice signal, the data signal, the combined voice and data signal and to the possible use of the free half-pair.

11. Connection block for use in facilities according to any of claims 1 to 7, characterised in that the block has a series of grouped contact pairs connectable so that for each four contact half-pairs one half-pair remains free, and the remaining half-pairs respectively are respectively connectable to the voice signal, the data high-speed xDSL signal, and the combined voice/data signal.

12. Connection block according to claim 11, characterised in that the half-pairs of the voice signal and of the combined voice/data signal have closed contacts, whilst the half-pair of the data signal has open contacts, so that said free half-pair can be used as a point of metallic access to obtain a signal and to lead it to a test desk.

13. Connection block according to claim 11 or 12, having an odd number of contact

pairs, so that each contact pair can be used in conjunction with a corresponding contact pair of a similar connection block when positioned adjacent thereto in use.

14. Connection block according to claim 13, positioned adjacent to a similar connection
5 block so that each contact pair of one of the blocks can be used in conjunction with a corresponding contact pair of the other block.

15. Facilities according to any of claims 1 to 6, characterized in that the connection
10 blocks (1) of the intermediate distribution frame (2) are grouped in parallel, functionally complementary pairs (1-1'), so that on a first one of said connection blocks (1'), the contact pairs (5) (5'), (5''), ... (5ⁿ) are used, for example, for the incoming voice signal, corresponding to the different lines assisted by the pair of connection blocks, and opposite the contact pairs (6), (6'), (6'')...(6ⁿ), are used, for example, for the outgoing combined voice + data signal, whilst on the other connection block (1), and facing the first one, the contact
15 pairs (3), (3'), (3'')...(3ⁿ), used, for example, for the incoming high-speed XDSL data signal, and the contact pairs (4), (4'), (4'')...(4ⁿ), which remain free as grounding points or points of metallic access, are arranged, so that each filter (7) acts simultaneously on both combined connection blocks (1-1').

20 16. Facilities according to claim 15, characterized in that each filter (7) is individual for each line and incorporates its contacts (9), established on two substantially parallel pins (8) at substantially the same separation distance as that between the relevant contacts of the respective connection blocks (1-1').

25

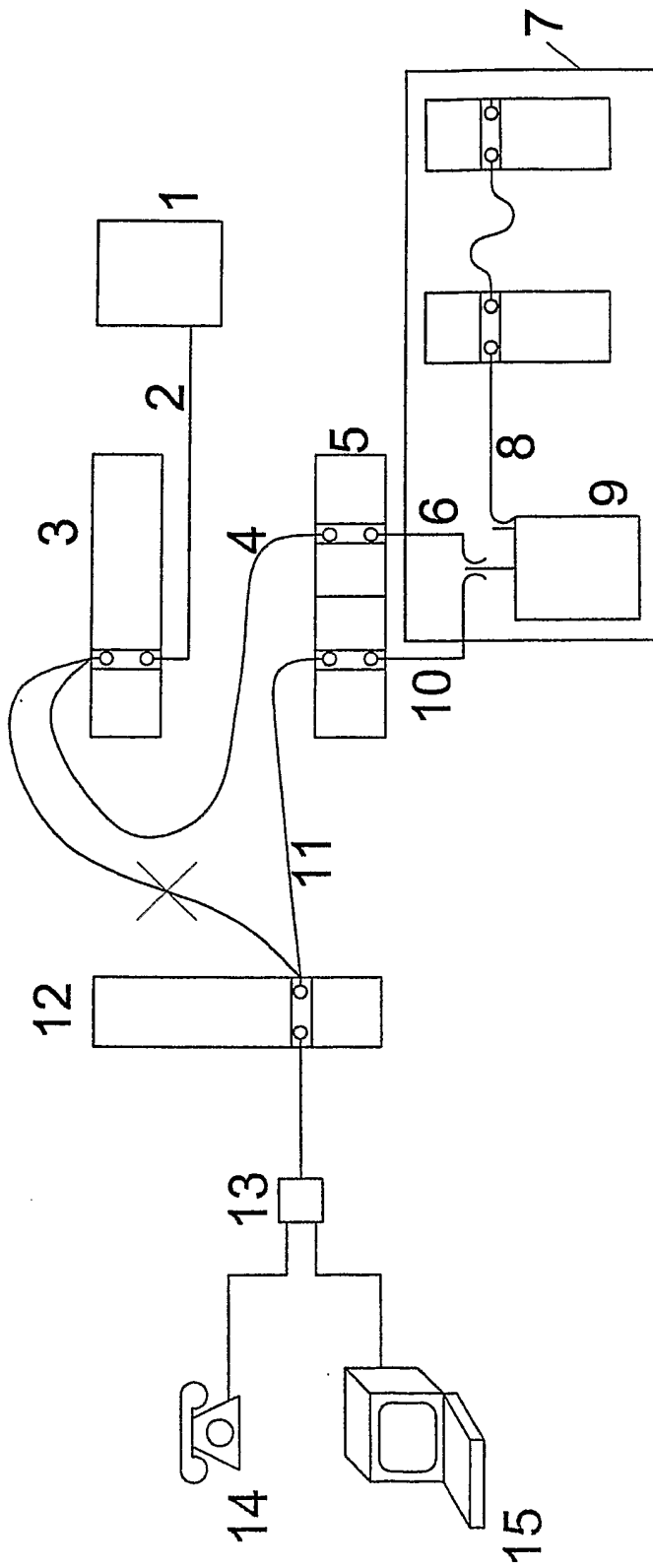

FIG. 1

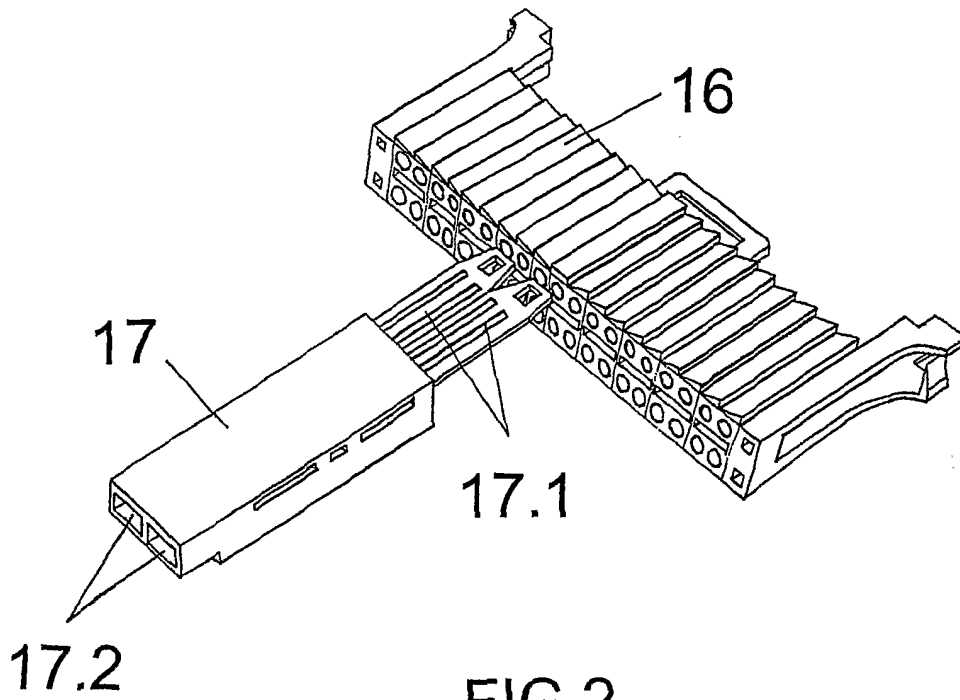

FIG. 2

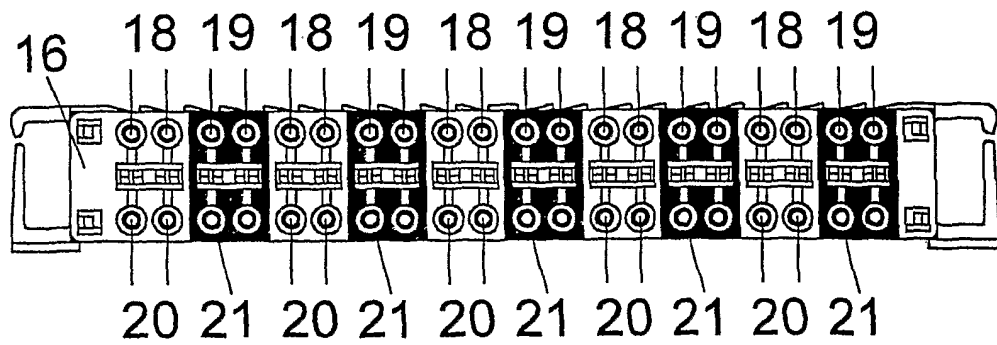

FIG. 3

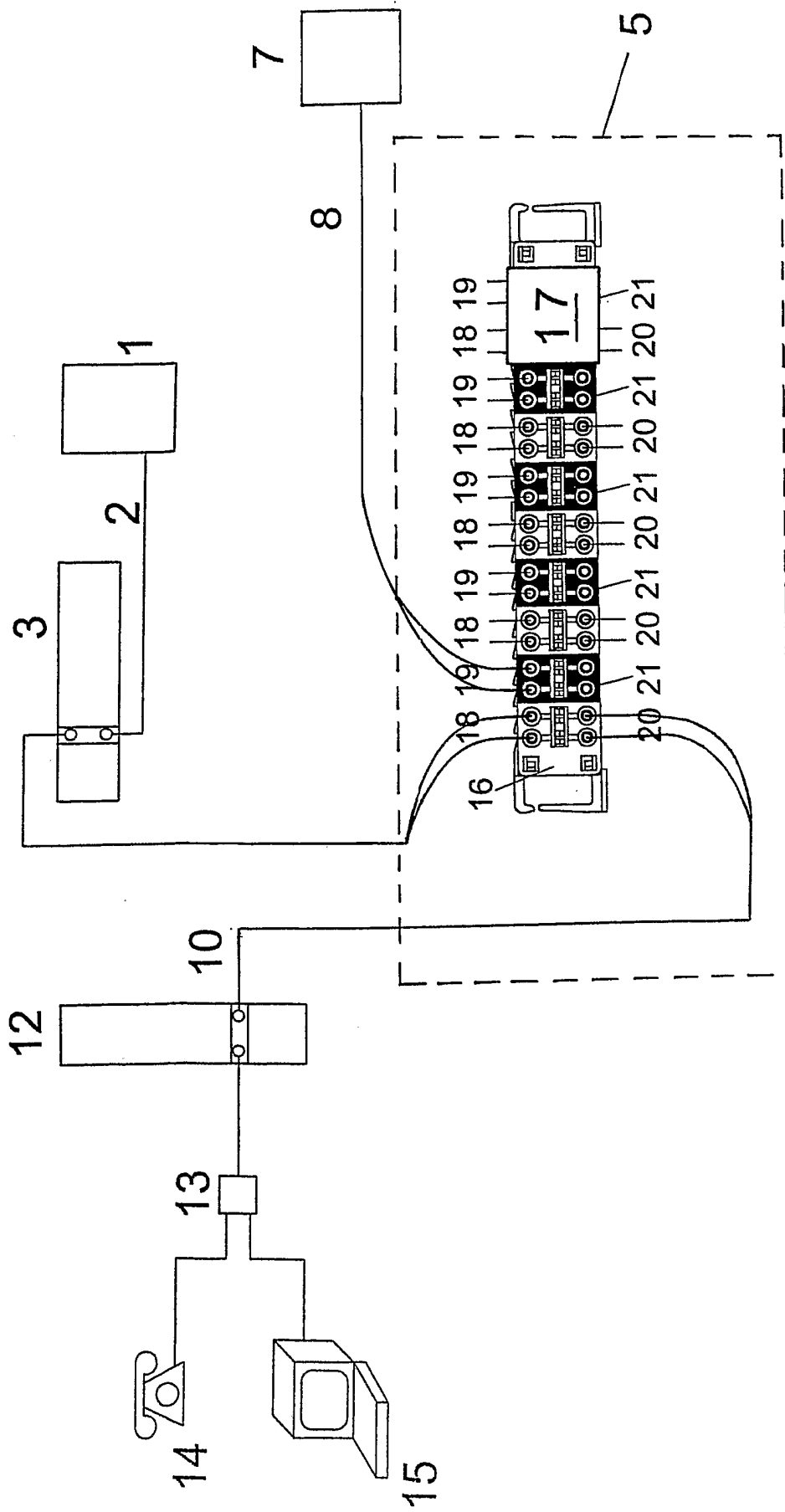

FIG. 4

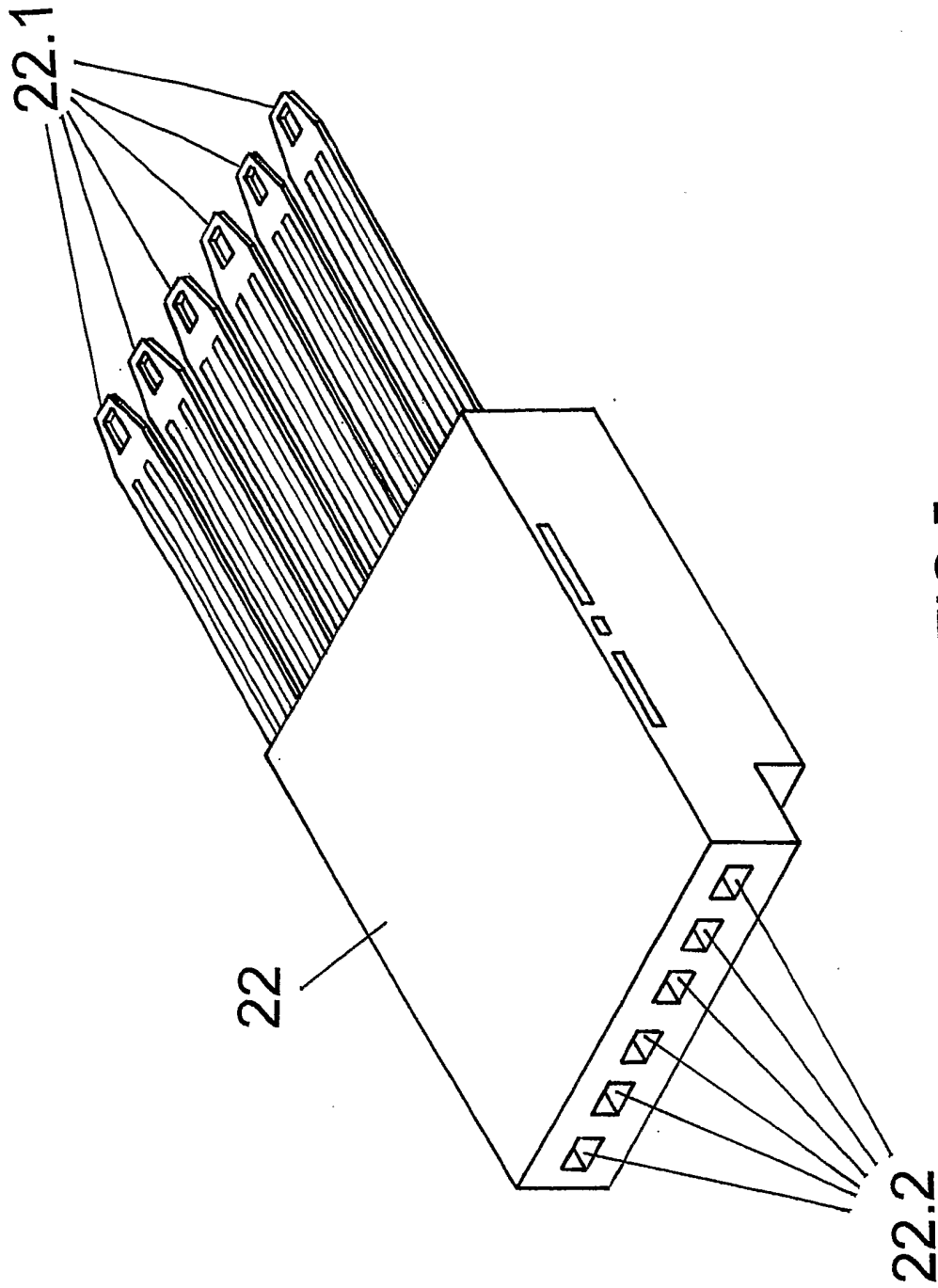

FIG.5

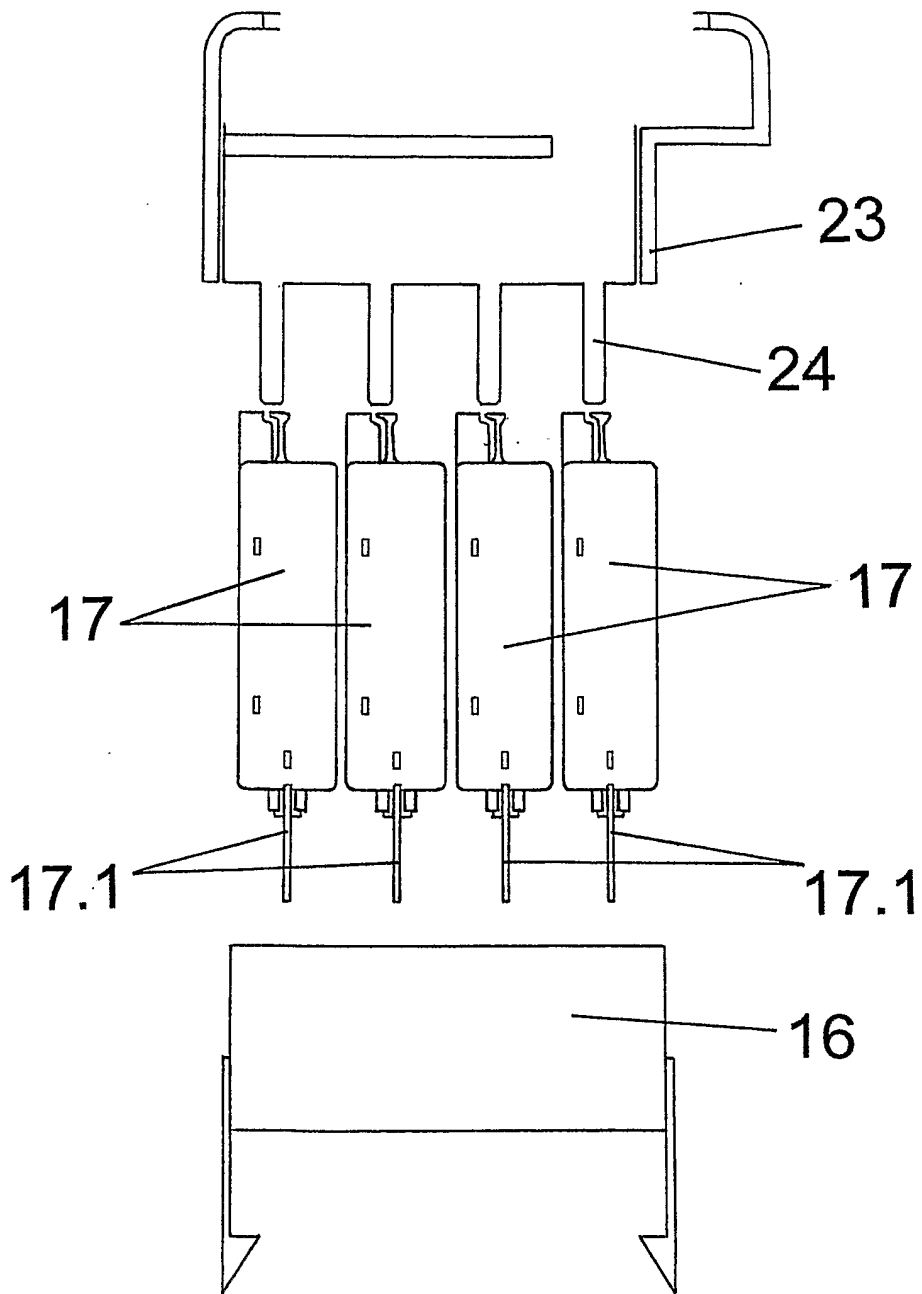

FIG.6

6/7

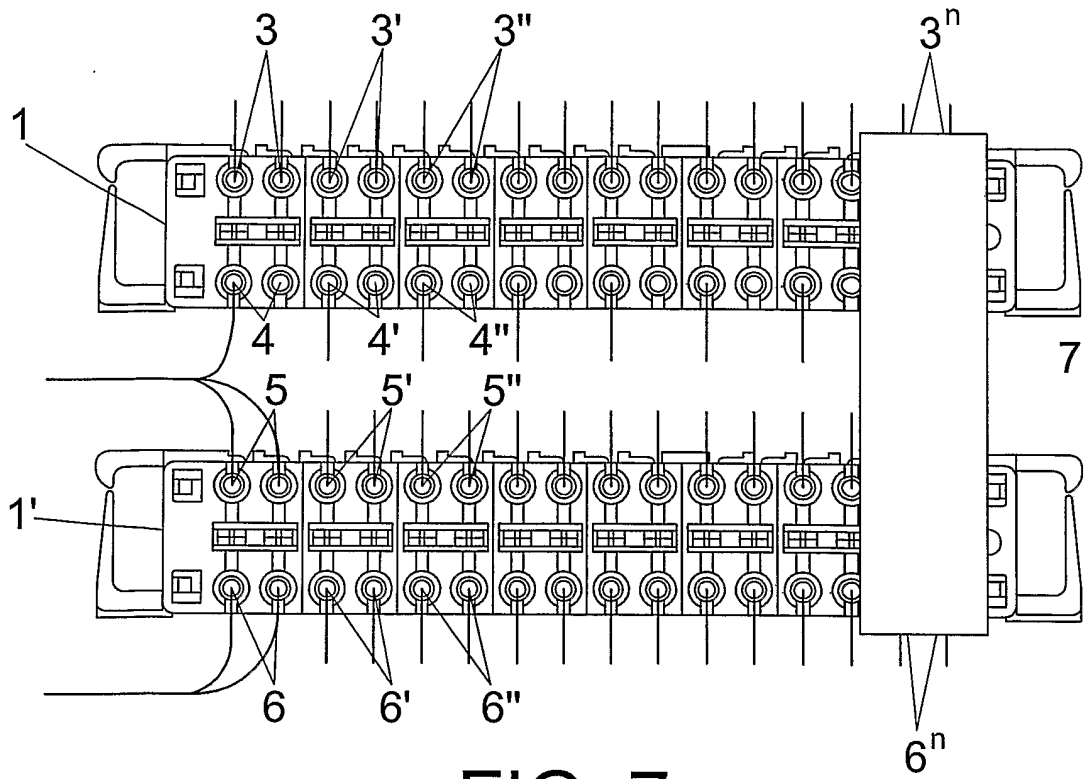

FIG. 7

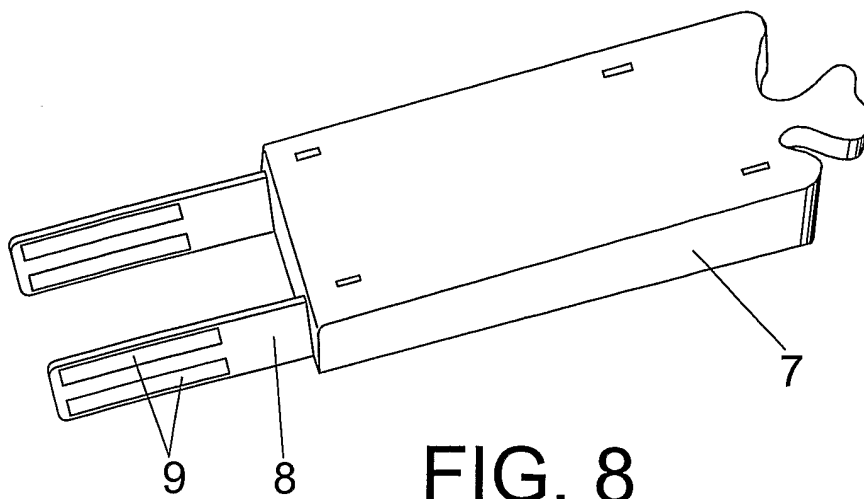

FIG. 8

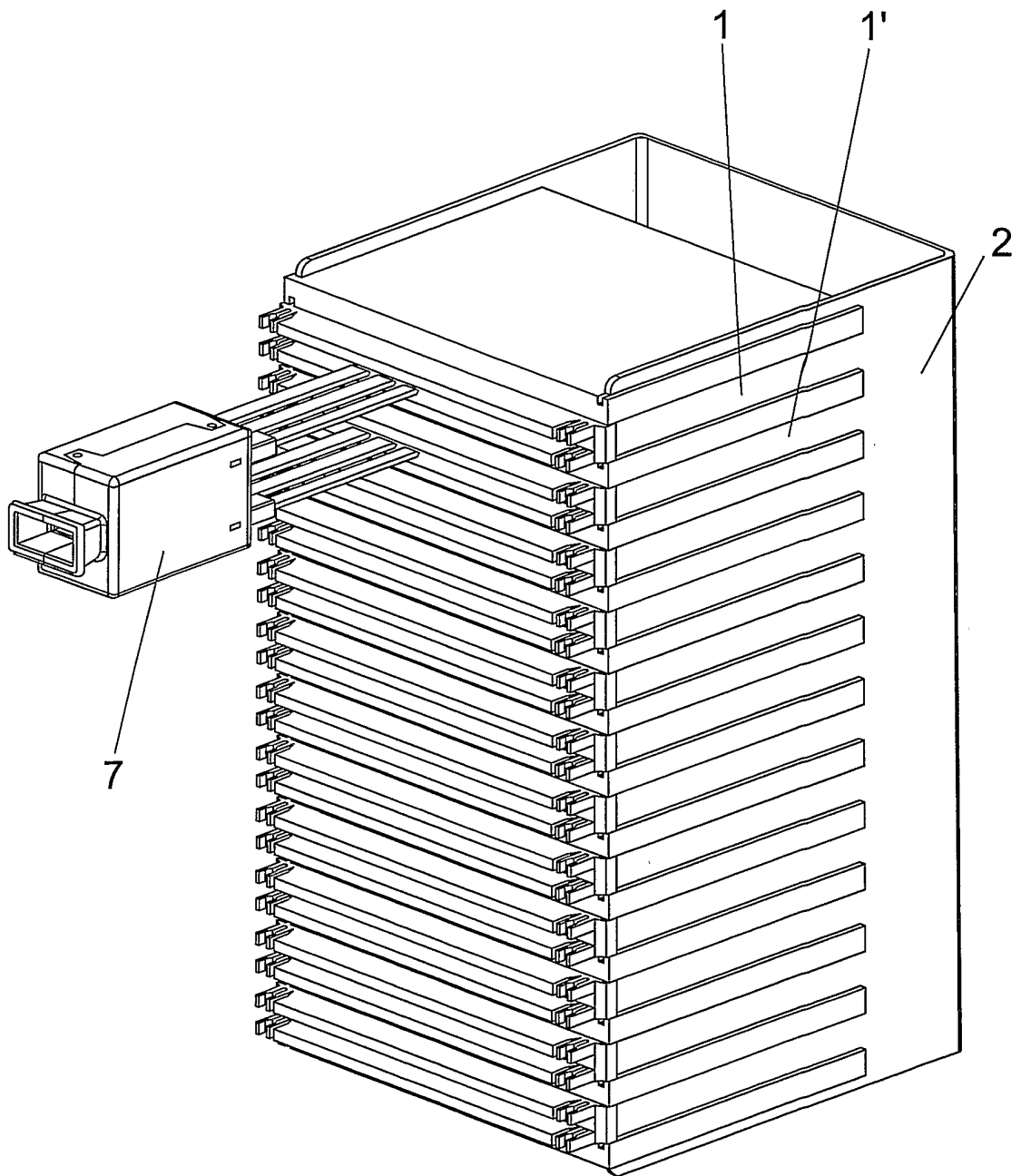

FIG. 9

INTERNATIONAL SEARCH REPORT

Internat Application No
PCT/GB 03/04027

A. CLASSIFICATION OF SUBJECT MATTER IPC 7 H04Q1/14				
According to International Patent Classification (IPC) or to both national classification and IPC				
B. FIELDS SEARCHED				
Minimum documentation searched (classification system followed by classification symbols) IPC 7 H04Q				
Documentation searched other than minimum documentation to the extent that such documents are included in the fields searched				
Electronic data base consulted during the International search (name of data base and, where practical, search terms used) WPI Data, EPO-Internal				
C. DOCUMENTS CONSIDERED TO BE RELEVANT				
Category ^o	Citation of document, with indication, where appropriate, of the relevant passages	Relevant to claim No.		
X	WO 02 069455 A (JORDE JOSE MANUEL ;MONDRAGON TELECOMM SL (ES); ARIAS JUAN TOMAS (E) 6 September 2002 (2002-09-06) page 4, line 24 -page 5, line 16 -----	1,2,6		
X	WO 00 76178 A (MPHASE CORP) 14 December 2000 (2000-12-14) page 6, line 29 -page 8, line 7 -----	1,6		
X	US 2002/106075 A1 (SAND PAUL RAYMOND ET AL) 8 August 2002 (2002-08-08) paragraphs '0039!', '0040!; figure 2 -----	1,2,6		
X	WO 01 45452 A (ADC TELECOMMUNICATIONS INC) 21 June 2001 (2001-06-21) page 16, line 17 - line 27; figures 9,20 ----- -/--	1,6		
<input checked="" type="checkbox"/> Further documents are listed in the continuation of box C.				
<input checked="" type="checkbox"/> Patent family members are listed in annex.				
^o Special categories of cited documents :				
<table style="width: 100%; border: none;"> <tr> <td style="width: 50%; vertical-align: top; padding: 5px;"> *A* document defining the general state of the art which is not considered to be of particular relevance *E* earlier document but published on or after the International filing date *L* document which may throw doubts on priority claim(s) or which is cited to establish the publication date of another citation or other special reason (as specified) *O* document referring to an oral disclosure, use, exhibition or other means *P* document published prior to the international filing date but later than the priority date claimed </td> <td style="width: 50%; vertical-align: top; padding: 5px;"> *T* later document published after the international filing date or priority date and not in conflict with the application but cited to understand the principle or theory underlying the invention *X* document of particular relevance; the claimed invention cannot be considered novel or cannot be considered to involve an inventive step when the document is taken alone *Y* document of particular relevance; the claimed invention cannot be considered to involve an inventive step when the document is combined with one or more other such documents, such combination being obvious to a person skilled in the art. *&* document member of the same patent family </td> </tr> </table>			*A* document defining the general state of the art which is not considered to be of particular relevance *E* earlier document but published on or after the International filing date *L* document which may throw doubts on priority claim(s) or which is cited to establish the publication date of another citation or other special reason (as specified) *O* document referring to an oral disclosure, use, exhibition or other means *P* document published prior to the international filing date but later than the priority date claimed	*T* later document published after the international filing date or priority date and not in conflict with the application but cited to understand the principle or theory underlying the invention *X* document of particular relevance; the claimed invention cannot be considered novel or cannot be considered to involve an inventive step when the document is taken alone *Y* document of particular relevance; the claimed invention cannot be considered to involve an inventive step when the document is combined with one or more other such documents, such combination being obvious to a person skilled in the art. *&* document member of the same patent family
A document defining the general state of the art which is not considered to be of particular relevance *E* earlier document but published on or after the International filing date *L* document which may throw doubts on priority claim(s) or which is cited to establish the publication date of another citation or other special reason (as specified) *O* document referring to an oral disclosure, use, exhibition or other means *P* document published prior to the international filing date but later than the priority date claimed	*T* later document published after the international filing date or priority date and not in conflict with the application but cited to understand the principle or theory underlying the invention *X* document of particular relevance; the claimed invention cannot be considered novel or cannot be considered to involve an inventive step when the document is taken alone *Y* document of particular relevance; the claimed invention cannot be considered to involve an inventive step when the document is combined with one or more other such documents, such combination being obvious to a person skilled in the art. *&* document member of the same patent family			
Date of the actual completion of the international search <p style="text-align: center;">6 February 2004</p>		Date of mailing of the international search report <p style="text-align: center;">16/02/2004</p>		
Name and mailing address of the ISA European Patent Office, P.B. 5818 Patentlaan 2 NL - 2280 HV Rijswijk Tel. (+31-70) 340-2040, Tx. 31 651 epo nl, Fax: (+31-70) 340-3016		Authorized officer <p style="text-align: center;">Vandevenne, M</p>		

INTERNATIONAL SEARCH REPORT

Internat Application No
PCT/GB 03/04027

C.(Continuation) DOCUMENTS CONSIDERED TO BE RELEVANT		
Category *	Citation of document, with indication, where appropriate, of the relevant passages	Relevant to claim No.
P,X	WO 03 030307 A (JORDE JOSE MANUEL ;MONDRAGON TELECOMM SL (ES); ARIAS JUAN TOMAS (E) 10 April 2003 (2003-04-10) page 4, line 17 -page 5, line 20; figures 4,5 -----	1,2,6

INTERNATIONAL SEARCH REPORT

Information on patent family members

Internat Application No

PCT/GB 03/04027

Patent document cited in search report	Publication date	Patent family member(s)	Publication date
WO 02069455	A	06-09-2002	ES 2193853 A1 01-11-2003
			BR 0205959 A 07-10-2003
			CZ 20032139 A3 12-11-2003
			EP 1364431 A1 26-11-2003
			WO 02069455 A1 06-09-2002
			WO 03030307 A1 10-04-2003
			NO 20033789 A 26-08-2003
			TR 200300503 T2 22-09-2003
			TR 200300504 T2 22-09-2003
WO 0076178	A	14-12-2000	US 6385315 B1 07-05-2002
			AU 4999400 A 28-12-2000
			WO 0076178 A1 14-12-2000
US 2002106075	A1	08-08-2002	NONE
WO 0145452	A	21-06-2001	AU 2262001 A 25-06-2001
			BR 0016444 A 22-04-2003
			CA 2396552 A1 21-06-2001
			CN 1435059 T 06-08-2003
			EP 1277353 A2 22-01-2003
			TW 518898 B 21-01-2003
			WO 0145452 A2 21-06-2001
			ZA 200205390 A 29-04-2003
WO 03030307	A	10-04-2003	ES 2193853 A1 01-11-2003
			BR 0205959 A 07-10-2003
			CZ 20032139 A3 12-11-2003
			EP 1364431 A1 26-11-2003
			WO 02069455 A1 06-09-2002
			WO 03030307 A1 10-04-2003
			NO 20033789 A 26-08-2003
			TR 200300503 T2 22-09-2003
			TR 200300504 T2 22-09-2003