

No. 871,345.

PATENTED NOV. 19, 1907.

E. E. KLEINSCHMIDT.
FISHING REEL.

APPLICATION FILED APR. 5, 1905.

2 SHEETS—SHEET 1.

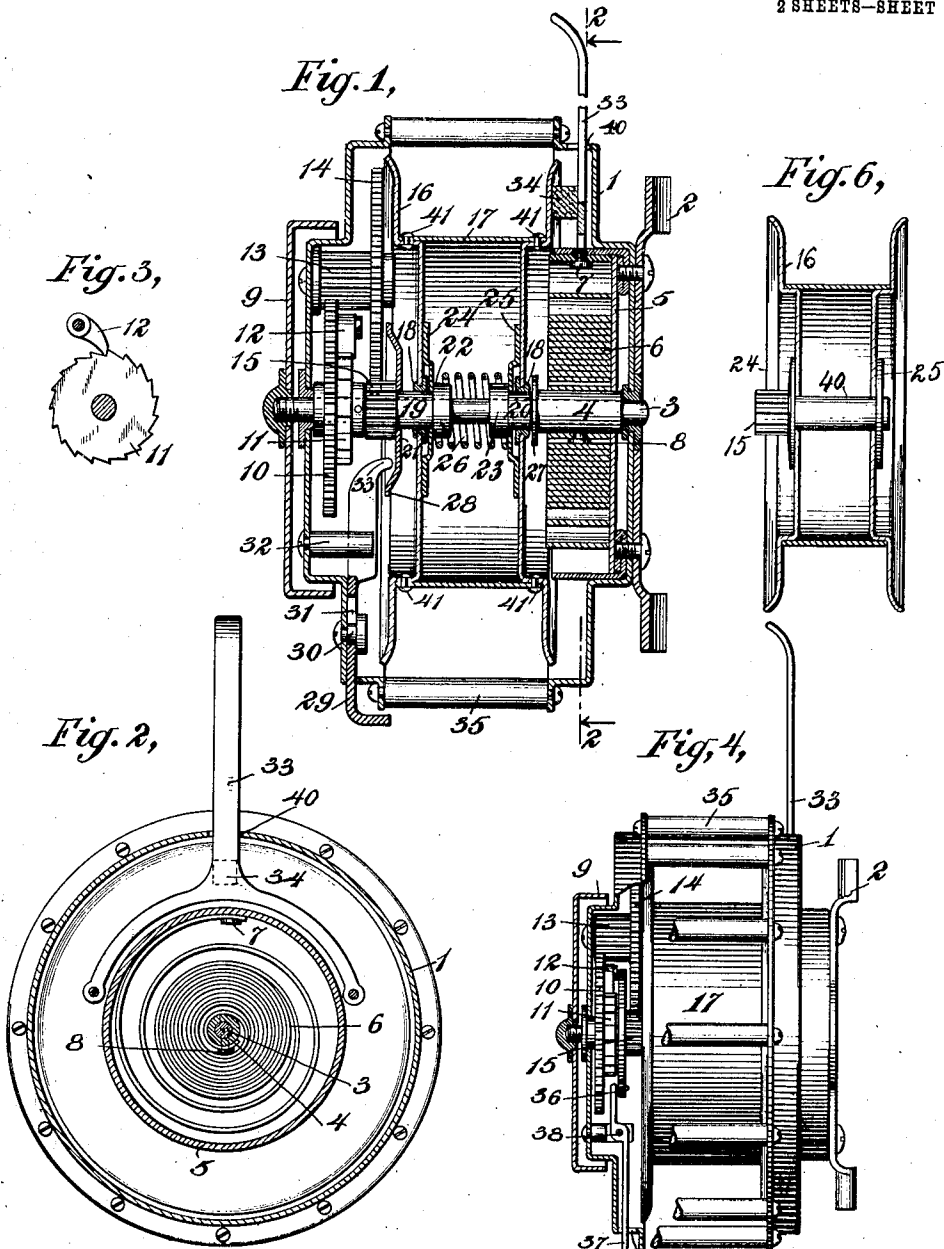

WITNESSES:

Grace L. Heasley.
Hans Schuag

Fig. 5,



INVENTOR.

Edward E. Kleinschmidt.

BY
Charles Spores
His ATTORNEY

No. 871,345.

PATENTED NOV. 19, 1907.

E. E. KLEINSCHMIDT.
FISHING REEL.

APPLICATION FILED APR. 5, 1906.

2 SHEETS—SHEET 2.

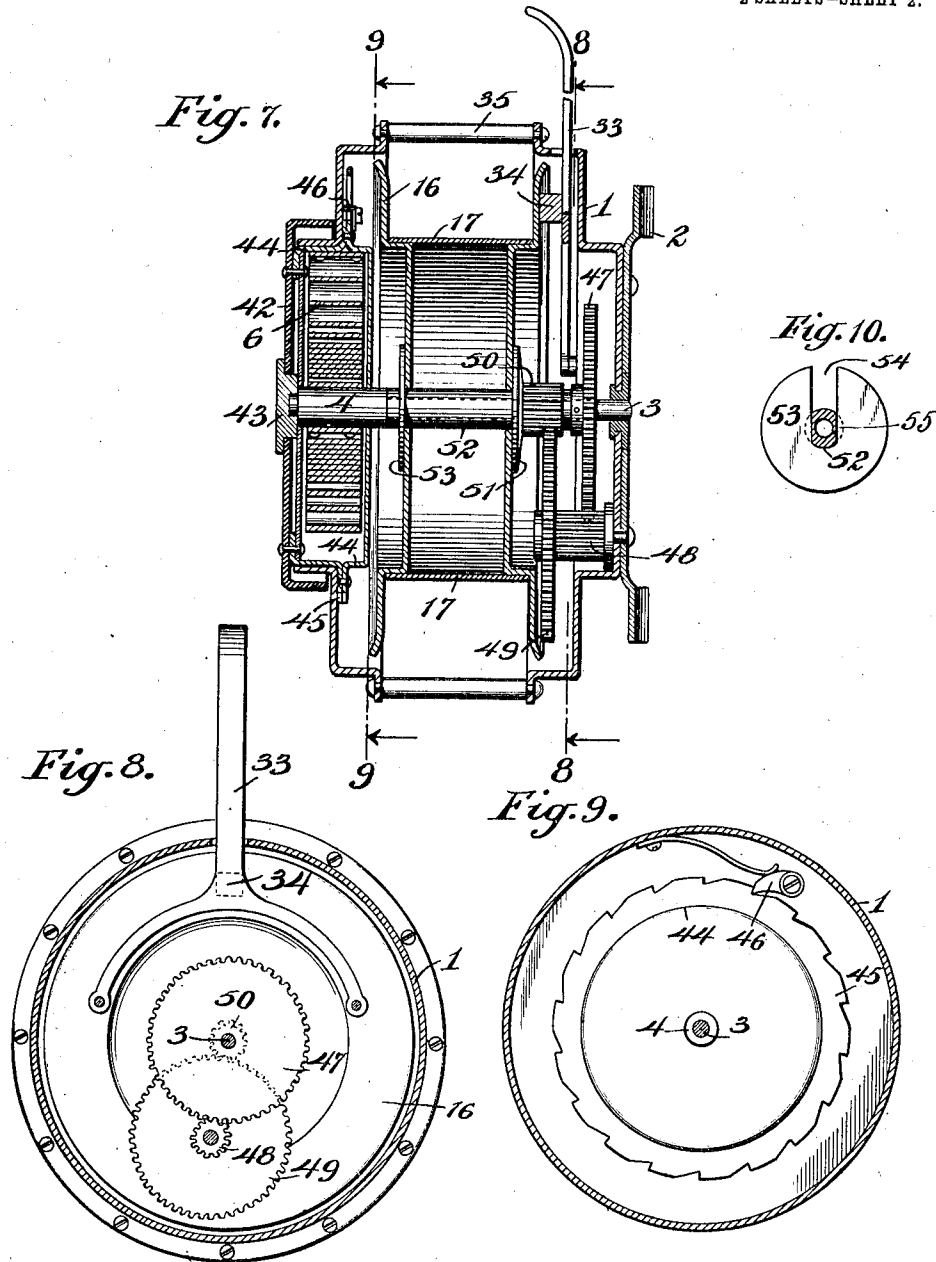

WITNESSES:
Grace L. Healey
Harry Schrage

INVENTOR
Edward E. Kleinschmidt
BY
Charles Jones
ATTORNEY

UNITED STATES PATENT OFFICE.

EDWARD E. KLEINSCHMIDT, OF NEW YORK, N. Y.

FISHING-REEL.

No. 871,345.

Specification of Letters Patent.

Patented Nov. 19, 1907.

Application filed April 5, 1905. Serial No. 253,927.

To all whom it may concern:

Be it known that I, EDWARD E. KLEINSCHMIDT, a citizen of the United States, and a resident of the borough of Manhattan, city, county, and State of New York, have invented certain new and useful Improvements in Fishing-Reels, of which the following is a specification.

The present invention relates to fishing reels and has for its object the construction of a reel which shall be simple and efficient in operation and in which the line may be run off by hand without danger of breaking or straining any of the parts and without throwing out of engagement any of the gears of the reducing train or otherwise disturbing the normal conditions of the several parts of the reel. This purpose of the invention is effected by the employment of friction disks which normally hold the spool in rotative engagement with the shaft in such manner however that the frictional resistance may be easily overcome by a pull on the line.

The invention also contemplates the employment of means by which the spool may be made free running, that is released altogether from engagement with the friction disks without disengaging the gears of the reducing train, so that the line may be cast without previously running off by hand. This is effected by means of what I have termed a throw-off lever which is adapted to move the friction disks from their normal positions, the whole throw-off mechanism with the friction disks constituting in effect a clutch.

The invention will be understood by reference to the accompanying drawings in which

Figure 1 is a vertical section of a reel embodying both features of my invention that is the friction disks and the throw-off mechanism; Fig. 2 is a sectional view on the plane of the line 2—2 of Fig. 1; Fig. 3 is a detail view of a pawl and ratchet; Fig. 4 is a view partly in section showing a modification of the throw-off lever; Fig. 5 is a detail of Fig. 4; Fig. 6 is a view showing a construction in which the friction disks are used without the throw-off mechanism; Fig. 7 is a vertical section of another form of reel without the throw-off mechanism; Fig. 8 is a sectional view on the plane of the line 8—8 of Fig. 7 and Fig. 9 is a sectional view on the plane of the line 9—9 of Fig. 7.

Similar reference numerals indicate similar parts in the several views.

As Figs. 1 to 5 inclusive show a construction embodying both the friction disks and the throw-off mechanism, I will describe such construction first.

Referring to the drawings the numeral 1 designates a casing of suitable form and proportions, usually made of light metal, such as aluminium. This casing is made in two parts secured together by the cross braces 35, thus permitting of ready assemblage of the parts and providing for their convenient arrangement. To one side of the casing is fixed the reel seat 2. In suitable bearings in the casing 1 is journaled a shaft 3 having fixed to one end thereof a collar 4. In the right-hand section of the casing, as shown in Fig. 1, is secured a spring drum 5 containing a spring 6 fastened at 8 to the collar 4 and at 7 to said drum, (Fig. 2). One end of the shaft 3 projects beyond the casing and is screw-threaded to receive a cap 9, said cap affording not only protection to the casing but serving also as a means for turning the shaft 3 for winding up the spring 6. The reducing gears are contained in the left-hand section of the casing, the train comprising a gear wheel 10 loosely mounted on the shaft 3, said wheel having fastened on its side a pawl 12 in engagement with a ratchet wheel 11 which is fast to the shaft 3. The gear wheel 10 meshes with a pinion 13 fast with a large gear wheel 14, the latter meshing with a pinion 15 having a loose bearing on the shaft 3.

Between the train of reducing gears and the spring 6 is mounted a spool 16 of suitable form to receive the line. The said spool is stepped into collars 18 having loose bearings on sleeves 19 and 20, the latter having loose bearings on the shaft 3. The pinion 15 is integral with the sleeve 19 and fixed to the latter is a flange 21 for the purpose more fully hereinafter described. The sleeve 19 is screw-threaded to receive a flanged head 22, it being necessary to make said flange removable in order to properly assemble the parts. The sleeve 20 has integral therewith a flanged head 23. Fastened to the head 22 of the sleeve 19 is a friction disk 24, and fastened to the head 23 of the sleeve 20 is a friction disk 25, these friction disks being of suitable shape and adapted to bear against the walls of the spool 16. A spring 26 sur-

rounding the flanged heads 22 and 23 is adapted to bear against said friction disks and to hold them in proper engagement with the spool 16. The collar 4 has integral therewith a flange 27 against which the sleeve 20 abuts.

To permit the spool 16 to run free upon the sleeves 19 & 20, I provide a throw-off lever 29, which, in the form shown in Fig. 1, is slidably mounted on the casing 1 over a stud 30, a slot 31 in the lever permitting such movement. A forked support 32 secured to the casing serves as a guide for the lever 29. The flange 21 is dish-shaped, the outwardly flaring wall having a flattened rim 28. The toe 33 of lever 29 is adapted to contact with the flaring wall of flange 21 and when drawn to its outermost position rests upon the flattened rim 28.

The reel as above described will be provided with any suitable form of brake shoe, such as 34, secured to a lever 33 projecting outside of the casing and under the control of the user. A slot 40 in the wall of the casing permits lever 33 to be sprung in and out thereby bringing the shoe 34 into or out of contact with the side of the spool 16.

As shown in Fig. 1 the spool 16 is composed of two similar sections, a cylindrical base piece 17 being riveted at 41 to a shoulder formed in each section, such construction being simple and cheap to make and providing a spool of sufficient rigidity and firmness for the purpose.

The reel above described is operated as follows: Spring 6 is wound by turning the cap 9 to the right, the ratchet 11 only of the train of gears turning with the shaft 3, pawl 12 acting to prevent reverse movement of said shaft. If it is desired to run the line off by hand it may be done by simply drawing on the line when the spool 16 will be rotated on the sleeves 19 and 20 and caused to slide over the faces of the friction disks 24 and 25. At such time the throw-off lever 29 is in the position shown in Fig. 1 and the brake 34 may or may not be released. If the brake is released care should be taken to maintain a hold on the line to prevent the spring 6, should it be wound, from imparting a reverse movement to the spool. It will be noted that in this operation the train of gears is not disturbed, and special provision for mounting the spring 6, such as its disengagement at one end, is unnecessary.

To release the spool from engagement with the friction disks altogether so as to permit the spool to run free to allow the line to be cast without previously running out by hand, the throw-off lever 29 is drawn outward and then the brake 34 released. As the toe 33 of lever 29 rides over the inclined face of flange 21 the latter is, with pinion 15 and sleeve 19, moved to the right, such movement however not being sufficient to take said pinion out of

engagement with the gear wheel 14. The friction disk 24 being secured to the flanged head 22 of sleeve 19 will also be moved to the right out of engagement with its wall of spool 16. Spring 26 at the same time being compressed tends to move friction disk 25 and sleeve 20 to which said disk is attached to the right, and as said sleeve always abuts against flange 27 no movement will be imparted to it, the effect being to release the friction disk 25 from engagement with its wall of the spool, the parts being so constructed and assembled as to leave a space between the right-hand collar 18, into which the spool 16 is stepped, and flange 27, permitting said spool to move to the right out of engagement with friction disk 25 when spring 26 is compressed. The friction disks thus being moved out of engagement with the spool the latter is free to rotate when the line is cast. It will be noted, as above, this freeing of the spool is effected without disengaging any of the gears of the reducing train, and should the spring 6 be wound no effect will be had upon the spool by the rotation of the shaft 3. After the line has been cast, the throw-off lever 29 is returned to the position shown in Fig. 1, and brake 34 set in its normal position. Said throw-off lever and brake may be manipulated in the manner described at any time when necessary to allow the spool 16 to run free. To draw in or rewind the line, the throw-off lever 29 must be in the position shown in Fig. 1, when upon releasing brake 34 the spring 6 when wound will act to rotate the shaft 3 and through the train of gears, beginning with ratchet wheel 11 which is fast to said shaft, and friction disks 24 and 25 to rotate spool 16, it being understood that the spring 26 acts to hold said disks in engagement with the walls of the spool with sufficient pressure to effect rotation of the spool.

The friction disks 24 and 25 and their actuating parts constitute in effect a clutch for engaging and disengaging the spool 16 with the shaft 3, and this feature of my invention I desire to claim broadly. A friction clutch of the character described avoids the necessity of disengaging any of the gears of the reducing train when the line is to be cast. It also permits the line to be drawn off by hand without danger of breaking the line or straining any of the parts, the spool in such case merely slipping on the friction disks.

In Fig. 4 I have shown a modification of the throw-off lever. In this form said lever 37 is pivoted to a bracket on the casing at 38. Instead of the dish-shaped flange 21 of Fig. 1, I employ a plain disk 36 which is integral with pinion 15, the latter being integral with sleeve 19, as in Fig. 1. All of the other parts of the mechanism of Fig. 4 are the same as above described with reference to Fig. 1. When operating the reel of Fig. 4 the lever 37 is

is moved on its pivot so as to bear against flange 36 thereby moving sleeve 19 to the right, effecting the disengagement of the friction disks 24 and 25 from the side walls of the spool, allowing the spool to run free. The lever 37 when moved as just described is held by a shoulder in a slot 39 in the casing 1.

In Fig. 6 I have shown a form of reel embodying some of the features above described. In this form the disks 24 and 25 instead of bearing on the inner wall of the spool are fast to a sleeve 40 having a loose bearing on the shaft 3, and are adapted to frictionally engage the outer walls of said spool. The pinion 15, as in Fig. 1, is integral with the disk 24. In the construction shown in Fig. 6, the disks 24 and 25 are at all times in engagement with spool 16, this form dispensing with throw-off lever 29 and flange 21, the line being drawn off by hand, causing the spool to slip on the friction disks. The spring 6 and the train of reducing gears will be the same as in Fig. 1. In Figs. 7, 8 and 9 I have shown another modification, which like the previously described reels is adapted to permit the drawing off of the line by hand without disengaging any of the gears or making special provision for mounting the rewinding spring. Referring now to these figures the casing 1 is made as before of two sections secured together by cross rods 35. The left-hand side of the casing is open as shown in Fig. 7 and that side is covered by a cap 42 having a hub 43 to provide a bearing for one end of the shaft 3, the other end of said shaft having a bearing in the opposite wall of the casing. A collar 4 the same as in Fig. 1, is secured fast to shaft 3 and to said collar is fastened one end of the spring 6, the outer end of said spring being secured to the inner wall of a drum 44. The said drum is formed of two sections, preferably of sheet metal, having outwardly extended flanges which when the two sections are secured together by rivets are stamped or cut with ratchet teeth 45, the drum 44 thus constituting a ratchet wheel. Or said drum may be a plain cylinder having a ratchet wheel secured to its periphery. The cap 42 is secured to the outer wall of the drum 44 by rivets so that as said cap is turned the spring 6 will be wound by turning the said drum and not by turning the shaft 3 as in Fig. 1. The ratchet teeth rest against the inner wall of the casing 1 and are engaged by a spring pressed pawl 46 to prevent reverse movement of the drum.

Keyed fast to shaft 3 is a spur gear 47 which meshes with a pinion 48, said pinion being fast with a spur gear 49, the latter in turn meshing with a pinion 50. A friction disk 51 is secured to the side of the pinion 50 and both said pinion and disk are fast on a

sleeve 52 which has a loose bearing on shaft 3. The said sleeve has also fast to it a second friction disk 53, said disks being normally and at all times in frictional engagement with the outer walls of the spool 16, the latter having a loose bearing on sleeve 52. A brake shoe 34 secured to a lever 33 is provided as in Fig. 1. The base 17 may be riveted to the side walls of spool 16 as shown in Fig. 1, or said base may be sprung into position the pressure of the friction disks upon the sides of the spool being sufficient to hold the base 17 in place. In this last described reel no throw-off lever is employed, the line being run off by hand, a pull on the line causing the spool to slide over the friction disks. This construction like the others obviates the necessity of special provisions for disengaging the gears or mounting the rewinding spring when the line is to be drawn off.

As shown in Fig. 10 the disk 53 is cut with a slot 54 so as to permit it to be slipped into grooves 55 formed on opposite sides of the sleeve 52. This enables a ready assemblage and dismantling of the parts of the spool, the grooves 55 being so placed as to secure a firm locking engagement against the side of the spool by means of said disk.

What I claim and desire to secure by Letters Patent is:—

1. In a fishing reel the combination of a line spool, a shaft, friction disks having loose bearings on said shaft and normally engaging said spool, and means for moving said disks longitudinally of the shaft to thereby release them from the spool.

2. In a fishing reel the combination of a line spool, a shaft, friction disks having loose bearings on said shaft and normally engaging said spool, means to rotate said shaft and thereby the spool when the line is to be wound, and means to move said disks into and out of engagement with the spool.

3. In a fishing reel the combination of a line spool, a shaft, sleeves having a loose bearing on said shaft, friction disks secured to said sleeves and normally engaging said spool, and means to shift one of said sleeves longitudinally of the shaft to thereby release the disks from engagement with the spool.

4. In a fishing reel the combination of a line spool, a shaft, sleeves having a loose bearing on said shaft, friction disks secured to said sleeves and normally engaging said spool, a train of reducing gears connected to said shaft, one of said gears being secured to one of said sleeves, and means to shift said latter sleeve longitudinally of the shaft to release the disks from engagement with the spool.

5. In a fishing reel the combination of a line spool, a shaft, sleeves having a loose bearing on said shaft, friction disks secured

to said sleeves and normally engaging said spool, a train of reducing gears connected to said shaft including a pinion having a loose bearing on the shaft and rigidly secured to one of said sleeves, a flange secured to said pinion, and a throw-off lever the movement of which in one direction will shift the pinion and its attached sleeve to thereby release the friction disks from engagement with the spool.

6. In a fishing reel the combination of a line spool, a shaft, a spring for rotating said shaft in one direction, a train of reducing gears connected to said shaft said train including a pinion having a loose bearing on the shaft, a flange secured to said pinion, friction disks having loose bearings on said shaft, a connection between said flange and disks, and a throw-off lever adapted to move

said flange to thereby release the disks from engagement with the spool.

7. In a fishing reel the combination of a line spool, a shaft, a spring connected to said shaft adapted to rotate it in one direction, a train of reducing gears connecting said shaft and spool, means for normally holding the spool in rotative engagement with one of the gears of said train, and means to disengage the spool so that it may run free without disturbing any of the gears of said train.

In testimony whereof I have hereunto signed my name in the presence of two subscribing witnesses.

EDWARD E. KLEINSCHMIDT.

Witnesses:

J. GALLWITZ,
GRACE L. HEASLEY.