

J. FLINDALL.
 RECLINING CHAIR.
 APPLICATION FILED APR. 28, 1906.

908,986.

Patented Jan. 5, 1909.

2 SHEETS—SHEET 1.

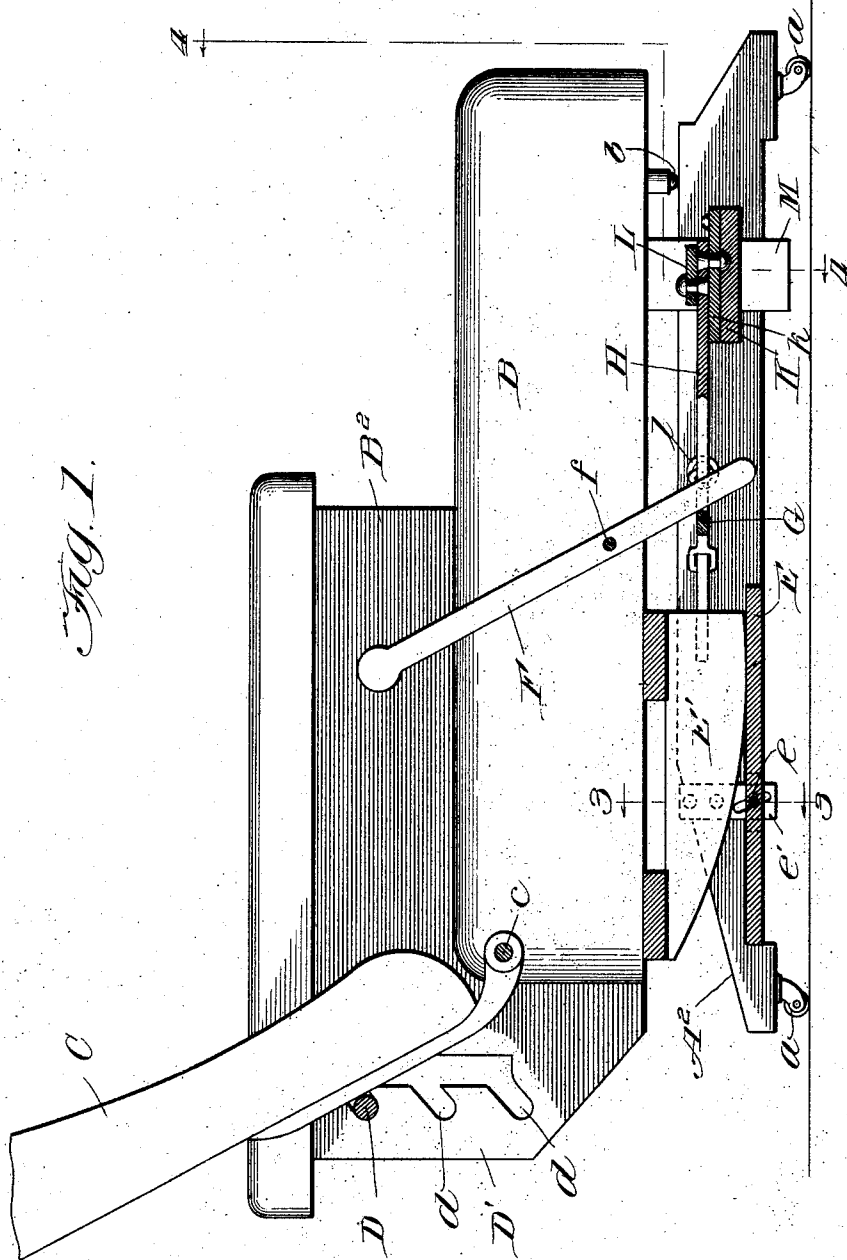

FIG. 1.

Witnesses:

H. S. Calkins

C. A. Mullen

Inventor:

John Flindall

*by Chamberlin Millison
 his Attorneys*

J. FLINDALL.
RECLINING CHAIR.

APPLICATION FILED APR. 28, 1906.

908,986.

Patented Jan. 5, 1909.

2 SHEETS—SHEET 2.

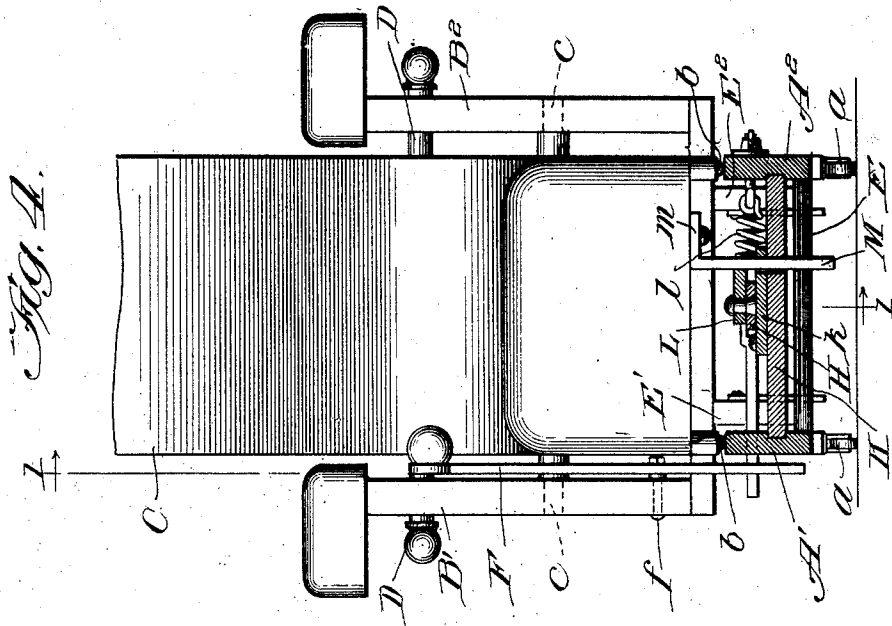

Fig. 1.

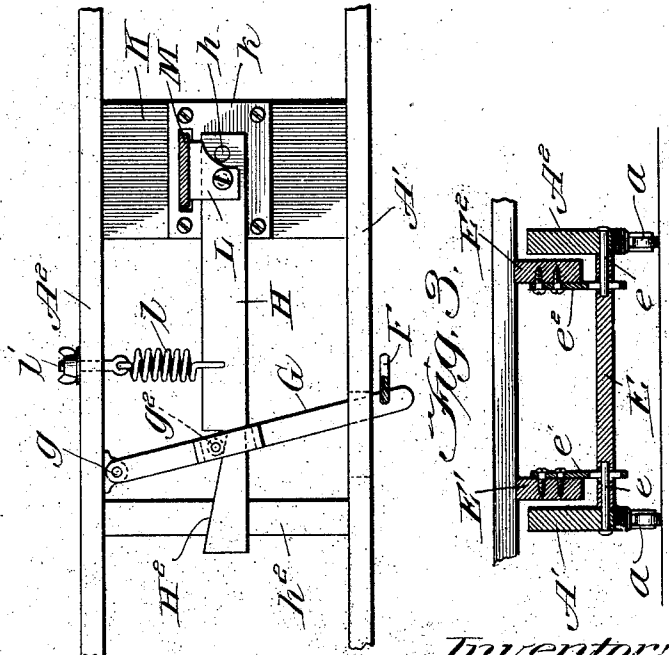

Fig. 2.

Fig. 3.

Witnesses:

H. S. Richter

C. A. Mullen

Inventor:

John Flindall

*by Chamberlin & Wilkinson
his attorneys*

UNITED STATES PATENT OFFICE.

JOHN FLINDALL, OF CHICAGO, ILLINOIS.

RECLINING-CHAIR.

No. 908,986.

Specification of Letters Patent.

Patented Jan. 5, 1909.

Application filed April 28, 1906. Serial No. 314,113.

To all whom it may concern:

Be it known that I, JOHN FLINDALL, a citizen of the United States, residing at Chicago, county of Cook, State of Illinois, have invented a certain new and useful Improvement in Reclining-Chairs, and declare the following to be a full, clear, and exact description of the same, such as will enable others skilled in the art to which it pertains to make and use the same, reference being had to the accompanying drawings, which form a part of this specification.

My invention relates in general to chairs, and more particularly to reclining chairs.

The primary object of my invention is to provide a chair the seat of which may be readily adjusted to any desired inclination by a person while sitting in the chair.

A further object of my invention is to provide a reclining chair the back of which may be adjusted relatively to the seat and the seat adjusted relatively to the supporting base thereby rendering it possible to make the chair comfortable for each particular occupant.

A still further object of my invention is to provide a reclining chair which will be simple in construction, inexpensive in manufacture, and comfortable in use.

My invention will be more fully described hereinafter with reference to the accompanying drawings in which,—

Figure 1 is a vertical sectional view taken on line 1—1 of Fig. 4; Fig. 2 a horizontal section; Fig. 3 a vertical section on line 3—3 Fig. 1, and Fig. 4 a vertical section on line 4—4 Fig. 1.

The same reference characters are used to designate the same parts in the several figures of the drawings.

B designates the seat of the chair located above the base and provided with rockers E' and E² beneath the same which are supported upon the horizontal portion E of the base. In order that the bottom may be limited in its movement relatively to the base, plates e' e² are fixed to the rockers E' E² and are provided with inclined slots through which extend rods e carried by the base.

b indicates stops secured to the underside of the seat and adapted to rest upon the upper surfaces of the side rails of the base when the seat is in a horizontal position.

B' B² indicate the arms of the chair which are fixed to the seat B.

C designates the back of the chair which is

pivotaly supported to the rear edge of the seat by suitable brackets, c.

D indicates a rod for supporting the back such rod engaging the notches d formed in a plate D' secured to each of the arms. The rod D may be located in any desired horizontal alined pair of notches to vary the inclination of the back.

A bracket M depends from the under surface of the seat B to which it is secured in any suitable manner as by means of a screw extending through the horizontal offset m thereof. The bracket extends through a slot in a plate k rigidly secured to the upper surface of the portion K of the base.

H designates a horizontal lever pivotaly supported at h upon the plate. A clutch L is pivotaly connected to the lever H adjacent its fulcrum and is adapted to engage the bracket M. A spring l connects the lever H to the side rail A² of the base, the tension of which normally oscillates the lever H to such a position that the clutch will grip the bracket M and immovably lock the same to the base. The tension of the spring may be adjusted by the nut on the screw l'. The end of the lever H opposite its fulcrum is provided with an inclined edge H² and is supported upon a transverse strip h² carried between the rails of the base.

G indicates a lever pivoted at one end to a bracket g fixed to the inner surface of the rail A² of the base. The end portion H² of the lever H extends through a slot in the lever G so that its inclined edge will be engaged by an anti-friction roller g² carried in the end of the slot in the lever G. The end of the lever G opposite its fulcrum projects to one side of the chair and is adapted to be engaged and operated by the lower end of a vertical lever F, the latter being pivotaly secured intermediate of its ends to the chair arms, and terminating at a point convenient to be reached by the occupant of the chair.

The manner of using and operation of my improved chair are as follows: The back is adjusted to the desired inclination relatively to the seat by means of the rod D. The occupant of the chair when he desires to vary his inclination presses the upper end of the lever F forwardly so that its lower end will oscillate the lever G. The oscillation of the lever G through the engagement of the roller g² thereon with the inclined edge on the end H² of the lever H swings the latter against the tension of the spring l and thereby disen-

gages the clutch L from the bracket M. The seat is then permitted to oscillate upon the rockers E' E² until it has the desired inclination when the pressure upon the lever F is released. The spring l thereupon forces the clutch L against the adjacent surface of the bracket M and tightly grips the same against the edge of the plate k' on the opposite side of the bracket from the clutch. The tension of the spring l also causes the lever G to be returned to its normal position through the engagement of the inclined edge on the lever H with the roller g² on the lever G.

From the foregoing description it will be observed that I have invented an improved reclining chair which may be readily adjusted to any desired position by the occupant thereof, and which by means of the cooperating adjustable back may be made to assume any position desired by the particular occupant.

Having now fully described my invention, what I claim as new and desire to secure by Letters Patent is:

1. In a reclining chair, the combination with a base, of a tilting seat mounted upon said base, rockers fixed to the under surface of said seat and resting upon said base, means for limiting the movement of said seat relatively to the base, a bracket secured to and depending from said seat, a horizontally swinging lever mounted upon said base, a clutch carried by said lever for engaging said bracket, a spring the tension of which swings said lever in a direction to apply said clutch to said bracket, a vertical lever extending to a point convenient for the occupant of the chair, and operative connections between said vertical and horizontal levers for swinging the latter against the tension of said spring.

2. In a reclining chair, the combination with a base, of a tilting seat mounted upon said base, a bracket secured to and depending from said seat, a plate fixed to said base through an opening in which said bracket extends, a horizontally swinging lever pivoted to said plate, a clutch carried by said lever adapted to engage said bracket to lock the seat to the base, a spring secured to said lever the tension of which swings the same in position to force the clutch thereon against said bracket, a second horizontally swinging lever pivoted to the base through a slot in which the end of said first lever extends, a vertical lever the lower end of which engages the end of said second horizontally swinging lever to oscillate the same and thereby oscillate said first lever against the tension of said spring to release the clutch from engagement with said bracket.

3. In a reclining chair, the combination with a base, of a tilting seat mounted upon said base, rockers fixed to the under surface of said seat and resting upon said base, a bracket secured to and depending from said seat, a horizontally swinging lever mounted upon said base, a clutch carried by said lever for engaging said bracket, a spring the tension of which swings said lever in a direction to apply said clutch to said bracket, a vertical lever extending to a point convenient for the occupant of the chair, and operative connections between said vertical and horizontal levers for swinging the latter against the tension of said spring.

In testimony whereof, I sign this specification in the presence of two witnesses.

JOHN FLINDALL.

Witnesses:

GEO. L. WILKINSON,
C. A. MULLEN.