

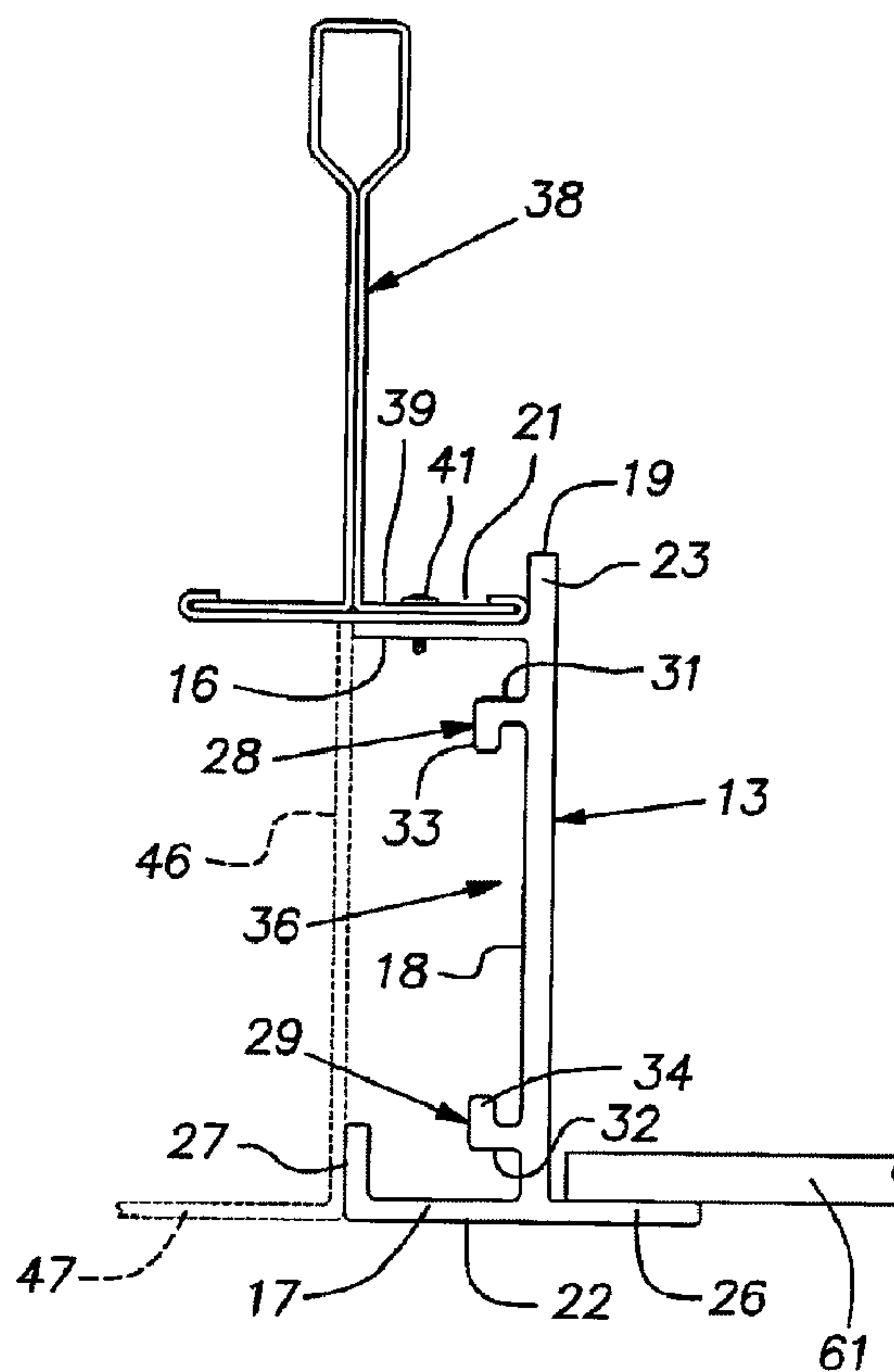

(22) Date de dépôt/Filing Date: 2017/01/16
(41) Mise à la disp. pub./Open to Public Insp.: 2017/07/19
(30) Priorité/Priority: 2016/01/19 (US15/000,060)

(51) Cl.Int./Int.Cl. *E04B 9/22* (2006.01),
E04B 9/04 (2006.01)
(71) Demandeur/Applicant:
USG INTERIORS, LLC, US
(72) Inventeurs/Inventors:
UNDERKOFER, ABRAHAM M., US;
GULBRANDSEN, PEDER J., US;
PAULSEN, MARK R., US
(74) Agent: GOWLING WLG (CANADA) LLP

(54) Titre : SYSTEME DE BANDE DE GARNITURE DESTINE A DES PANNEAUX DE PLAFOND SUSPENDU
(54) Title: TRIM STRIP SYSTEM FOR USE WITH UNDERHUNG CEILING PANELS



(57) Abrégé/Abstract:

In combination, extruded aluminum trim strips joined end-to-end and a splice plate, the trim strips together, the trim strip cross-sections including a web and a pair of opposed angles, the angles and web forming a track for receiving a mid-section of the splice

(57) **Abrégé(suite)/Abstract(continued):**

plate with a close sliding fit, the splice plate having lever tabs at opposite ends, notches at sides of the plate, the plate being disposed in the tracks of both lengths of trim strips, the lever tabs and associated edges of the lever tabs formed by the notches being outside of the tracks, the associated edge being arranged in a locking manner with outer surfaces of the angles as a result of the lever tabs being bent in place towards the web.

4656 CA

TRIM STRIP SYSTEM FOR USE WITH UNDERHUNG CEILING PANELS**ABSTRACT OF THE DISCLOSURE**

In combination, extruded aluminum trim strips joined end-to-end and a splice plate, the trim strips together, the trim strip cross-sections including a web and a pair of opposed angles, the angles and web forming a track for receiving a mid-section of the splice plate with a close sliding fit, the splice plate having lever tabs at opposite ends, notches at sides of the plate, the plate being disposed in the tracks of both lengths of trim strips, the lever tabs and associated edges of the lever tabs formed by the notches being outside of the tracks, the associated edge being arranged in a locking manner with outer surfaces of the angles as a result of the lever tabs being bent in place towards the web.

4656 CA

TRIM STRIP SYSTEM FOR USE WITH UNDERHUNG CEILING PANELS**BACKGROUND OF THE INVENTION**

The invention relates to accessories for edge trimming
5 pan-shaped downwardly accessible suspended ceiling panels.

PRIOR ART

A category of ceiling panels are of a type hung below
a suspended grid. Panels of this style are typically attached
10 to the grid with torsion springs carried on the panels. The
torsion springs draw the panels up against a lower face of the
grid elements. This type of panel allows for downward
accessibility into the plenum above the ceiling and can be
arranged to conceal the grid and provide a monolithic
15 appearance for the ceiling.

There exists a need for componentry for trimming or
finishing the edges of the described panels where the edges
are exposed such as where the ceiling is interrupted for
lighting or other utilities.

20

SUMMARY OF THE INVENTION

The invention provides a trim strip having a unique
configuration enabling it to be attached to a grid member and
to conceal both the grid member and an edge of an adjacent
25 pan-shaped underhung ceiling panel. The trim strip is
proportioned to match the depth of the ceiling panels so that
it is visually integrated with the ceiling panels. The
disclosed trim strip is arranged to receive a unique splice
plate that can be conveniently used for both miter joints and
30 butt joints. The splice plate is received in a track on the
inside face of the trim strip. Locking tabs on the splice
plate are deployed, typically without tools, to tightly lock
the splice plate to joined ends of two lengths of the trim
strip. The locking elements of the splice plate are arranged

4656 CA

to bear against areas remote from the material directly behind the strip faces so that the risk of distorting a face with a locking force is eliminated.

5

BRIEF DESCRIPTION OF THE DRAWINGS

FIG. 1 is a fragmentary perspective view of a corner of a perimeter frame embodying the invention for a light fixture or other utility opening in a suspended ceiling constructed of a trim strip of the invention;

10

FIG. 2 is a side perspective view of a butt joint between two spliced trim strip lengths embodying the invention;

15

FIG. 3 is an end view of one form of the trim strip of the invention installed on a grid member and visually finishing the edge of a pan-shaped ceiling panel shown in phantom;

FIG. 4 is an end view of another form of the trim strip of the invention installed on a grid member and visually finishing the edge of a pan-shaped ceiling panel shown in phantom;

20

FIG. 5 is a perspective view of a trim strip splice plate of the invention;

FIG. 6 is a plan view of the splice plate;

FIG. 7 is a side view of the splice plate;

FIG. 8 is an end view of the splice plate; and

25

FIG. 9 is a sectional view of a lever tab of the splice plate taken in the plane 9-9 indicated in FIG. 7.

DESCRIPTION OF THE PREFERRED EMBODIMENT

FIG. 1 illustrates an outer view of an "inside" miter joint 10 of two lengths of the inventive trim strip 11. The broken lines illustrated in FIG. 1 show a rectangular form fabricated of four lengths of the trim strip 11 in a rectangular frame 12. The illustrated frame 12 has the rectangular shape of a square that has nominal 2 foot by 2

4656 CA

foot dimensions of a conventional suspended ceiling grid module. The frame 12 can be assembled in other standard nominal rectangular sizes such as 2 foot by 4 foot. Dimensions used herein may be replaced by industry metric
5 equivalents.

Different versions of a trim strip 11 and 13 are disclosed. Herein, the term "trim strip" relates to both versions 11 and 13 unless the context indicates otherwise.

The trim strip is preferably formed as an elongated
10 unitary or one piece aluminum extrusion and may be painted or powder coated with a white or other desired color on its visible surfaces. The trim strip has the general shape of a channel with upper and lower horizontal flanges 16, 17, respectively, jointed by a vertical web 18. An extension 19
15 of the web 18 extends somewhat above the upper flange 16. Each trim strip 11, 13 is nominally 1-5/8 inch tall. A top surface 21 of the horizontal flange 16 is 1-1/2 inch above a lower surface 22 of the lower horizontal flange 17. The trim strip 13 of FIG. 4 has a horizontal extension 26 of the lower
20 horizontal flange 17 on the side of the web 18 opposite the side on which the main part of the flange exists.

The lower flange 17 has a vertical lip 27 at its distal edge. The trim strip includes a pair of mutually facing angles 28, 29 integral with the web 18. The angles 28, 29
25 include a horizontal leg 31, 32 and a distal vertical leg 33, 34. The vertical spacing between the horizontal legs 31, 32 and the spacing of the vertical legs 33, 34 from the web 18 is maintained with sufficient accuracy such that collectively they form a track 36 in which is received a splice plate,
30 discussed below, with a close sliding fit. Preferably, the elements of the trim strip have a uniform wall thickness except for the upper flange 16 which is made thinner to facilitate reception of a self-drilling screw as discussed below.

4656 CA

FIGS. 3 and 4 illustrate a typical mounting of a trim strip 11, 12 on a grid member 38. The image of the grid member 38 represents a standard grid tee or grid runner typically in the form of a main runner and special cross runners having slotted lower flanges for reception of torsion springs as is known in the industry and illustrated, for example, in U.S. Patent 9,228,347. A trim strip is mounted on a grid member 38 by abutting the upper surface 21 of the upper flange 16 against the lower face of a flange 39 of the grid runner 38 and the upper extension 19 of the web 18 against a distal edge of the grid member flange 39. A series of short self-drilling screws (only one is shown in FIGS. 3 and 4) spaced along the length of the trim strip are driven downwardly through the grid member flange 39 and the trim strip upper flange 16 to fix the trim strip to the grid runner 38.

A principle use of the trim strip is to finish the edge of a pan-shaped metal ceiling panel 46, shown in phantom in FIGS. 3 and 4, where the panel edge would be otherwise exposed. This situation will occur, for example, where an adjoining panel is omitted to leave an opening for a light fixture or other utility such as an air supply or return vent or an audio speaker.

It will be understood, as suggested in FIGS. 3 and 4, the trim strip 11 or 13 will occupy one-half the width of the grid runner flange 39 while the periphery of a ceiling panel will occupy the other half. Note that the trim strips are proportioned so that when installed, their lower faces 22 are coplanar with a main face 47 of the adjacent ceiling panel 46.

Where a full module space in a suspension grid is devoted to a light fixture or other utility device, the trim strip 11 or 13 is fabricated into a rectangular frame dimensioned so that the upper part or extension 23 of the web of each trim strip side fits closely with the grid flanges 39 at the inner

4656 CA

periphery of the module. To accomplish this, the lengths of the trim strip are cut at 45 degrees to produce miter joints such as shown in FIG. 1. Upper flanges 16 of the assembled lengths of the trim strip are raised up against the lower
 5 surface of the flanges 39 of the grid members 38 defining the module. The rectangular frame 12 is then fixed in place preferably with self-tapping screws 41 down through the grid flanges 39 into the upper flanges 16 or with equivalent fastening elements.

10 FIGS. 5 - 9 illustrate a metal splice plate 50 preferably formed as a one-piece sheet steel stamping of, for example, .047 inch hot dipped galvanized stock. The illustrated splice plate 50 is an elongated element having a flat rectangular mid-section 51 and inclined lever tabs 52 at each end. The
 15 mid-section 51 is weakened across two transverse lines by edge notches 53 and a hole 54 to form potential hinge lines for bending the splice plate 50 into a 90 degree angle. The splice plate 50 is embossed across land areas 55 between the notches 53 and hole 54 in the direction the lever tabs 52 are
 20 displaced before being deployed. A weakened hinge line is similarly provided at the juncture between the mid-section 51 and each lever tab 52 by edge notches 56 and a central slot 57. The lever tabs include laterally outlying grips 58 adjacent the mid-section 51. Lower edges 59 of the grips at
 25 the edge notches 53 are maintained relatively sharp during the stamping process to facilitate their "bite" onto a trim strip as discussed below. To augment the biting or gripping action of the tab edges 59, the grips 58 are stamped slightly downwardly out of the plane of the lever tab proper as shown
 30 in FIG. 9.

The splice plate 50 is used to make miter and butt joints between lengths of the trim strips 11, 13. FIG. 1 illustrates the splice plate 50 holding joined lengths of trim strip abutted in an "inside" corner construction. Use of the term

4656 CA

"inside" is in a traditional sense where the visible sides of the webs 18 are facing generally towards one another. The thickness and width of the plate mid-section 51 is proportioned to provide a close sliding fit within the track 36 established by the angles 28, 29. With the splice plate 50 bent into a right angle at one of the lines of the edge notches 53 and hole 54, each end of the mid-section 51 is inserted in a respective track 36 of one of the two lengths of trim strip to be joined at a corner. Initially, the lower edges 59 of the lever tab notches 56 are displaced from the plane of the top of the mid-section 51 a distance greater than the wall thickness of the vertical legs 33, 34 of the trim strip track 36. This spacing of the edges 59 allows the lever tab grips 58 to pass freely along outer surfaces of the vertical legs 33, 34. The initial orientation of the lever tabs 52 is shown in FIGS. 5 and 7.

The lever tabs 52 are deployed to lock the splice plate 50 and an associated trim strip length. As a lever tab 52 is depressed towards the web 18 of the respective trim strip length, the sharp edges 59 of the grips 58 bite into and lock onto respective track legs 33, the material of a trim strip preferably being softer than that of the splice plate 50. The material of the splice plate 50 is sufficiently malleable that a lever tab 52 does not appreciably spring back towards its original incline position.

The embossed area 55 where the splice plate 50 is hinged, avoids an interference of this hinge area with the ends of the trim strips at their webs 18 at a frame corner. With four splice plates 50 installed at the four corners, the frame 12 is a rigid assembly.

The trim strips 11 or 13 can be used to form the edges of several adjacent ceiling panels such as in narrow utility channel systems. More than one full length of trim strip may be needed to span the collective length of the panel edges.

4656 CA

In such a case, two trim strips can be spliced by the disclosed splice plate 50. In this situation, shown in FIG. 2, the splice plate mid-section remains flat and is centered over the abutted ends of the lengths of trim strips. The splice plate 50 is locked in place on the two ends of the trim strips in the same manner as described in connection with the miter joint shown in FIG. 1. Specifically, the lever tabs 52 are pressed towards respective trim strip webs 18 to cause the edges 59 to lock on the track angle legs 33.

10 It will be appreciated that the locking forces developed by the lever tab grips 58 is supplied to parts of the trim strip that are remote from the exposed or finished face of the trim strip so that there is no risk that this locking force will cause a visible distortion in the visible face.

15 The version of the trim strip 13 shown in FIG. 4 is useful where it is desired that a ceiling opening such as for a light or air duct have a semi-flush membrane of, for example, transparent or translucent material, or a grill. In such a case, the membrane 61 can be installed on top of the horizontal extension 26. In a square opening, the horizontal extension 26 will extend on four sides of the opening. In a narrow utility channel, the horizontal extension can be arranged on both sides of the channel to support opposite edges of the membrane 61.

25 It should be evident that this disclosure is by way of example and that various changes may be made by adding, modifying or eliminating details without departing from the fair scope of the teaching contained in this disclosure. The invention is therefore not limited to particular details of this disclosure except to the extent that the following claims are necessarily so limited.

30

4656 CA

WHAT IS CLAIMED IS:

1. In combination, two lengths of an extruded aluminum trim strip joined end-to-end and a splice plate having a sheet metal body securing the trim strip lengths together, the trim strip lengths having identical cross-sections including a web and a pair of opposed angles each of dimensions small compared to a width of the web, the angles and web forming a C-shaped track for receiving a mid-section of the splice plate with a close sliding fit, the splice plate having lever tabs at opposite ends of the mid-section, notches at sides of the body at a juncture of the mid-section and lever tabs, the mid-section being disposed in the tracks of both lengths of trim strips, the lever tabs and associated edges of the lever tabs formed by the notches being outside of the tracks at least at locations adjacent the junctures, the associated edge being arranged in a locking manner with outer surfaces of the angles as a result of the lever tabs being bent in place towards the web.

2. A combination as set forth in claim 1, wherein the web has a vertical height greater than 1-1/2 inch whereby the web is adapted to cover the edge of a nominal 1-1/2 inch pan-shaped ceiling tile located under a grid runner and indexed against a side of the grid runner.

3. An elongated trim strip for use with pan-shaped, below grid suspended ceiling panels comprising an extruded aluminum body, the body having a channel configuration with a pair of horizontal flanges integral with and extending in the same direction from a vertical web, a pair of spaced opposed track forming projections integral with the web and between the flanges, the flanges and projections extending along the length of the body, each projection forming a slot open

4656 CA

10 towards the other projection whereby the slots are constructed
and arranged to receive a splice plate.

4. A trim strip as set forth in claim 3, wherein an upper one of said flanges is thinner than the web and lower one of the flanges to facilitate reception of a self-drilling screw.

5. A trim strip as set forth in claim 4, wherein the projections have a wall thickness equal to a wall thickness of the web.

6. A trim strip as set forth in claim 3, wherein said formations are right angles in cross-section and are formed by horizontal and vertical legs.

7. A trim strip as set forth in claim 3, wherein the web extends above the upper flange and is adapted to abut the side of a grid member.

5 8. A splice plate comprising a sheet metal body having a nominal thickness, a mid-section having opposed faces, lever tabs at each end of the mid-section and extending to one side of the body, a notch on each side of the body at a juncture of
10 a lever tab and the mid-section, an edge of the notch spaced from a plane of an adjacent face of the mid-section, the mid-section having a transverse hinge line, a formation of the notch providing a relatively sharp edge transverse to a direction extending between the lever tabs at a side of the body opposite the one side from which the tabs extend, the mid-section having a transverse width adjacent each notch, the lever tabs each having a transverse width adjacent the notch that is greater than the width of the body at inward regions of the notch whereby the sharp edge is adapted to cut into a

4656 CA

15 softer aluminum body disposed in the notch when the respective lever tab is bent towards a plane of the mid-section, a weakened area between the lever tabs forming said hinge line to permit the body to be folded to a 90 degree angle at the hinge line at a miter joint between two trim strips.

9. A splice plate as set forth in claim 8, including an aperture midway between said adjacent opposed notches.

10. A splice plate as set forth in claim 8, wherein said edge is disposed above said plane a distance at least equal to the nominal thickness of the body.

11. A splice plate as set forth in claim 8, wherein the body is embossed at the hinge line of weakness in a direction to which said lever tabs are directed.

1/3

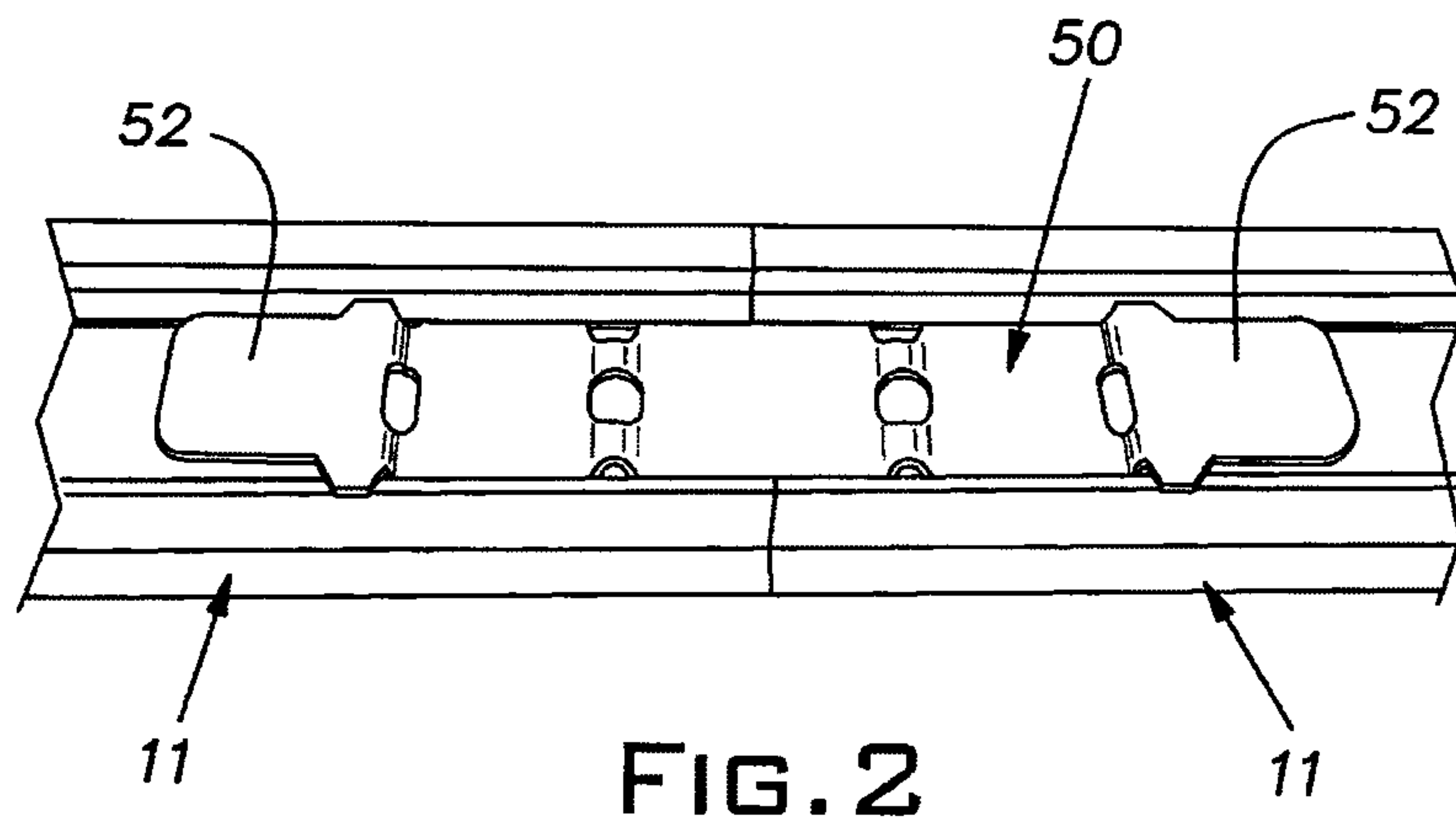
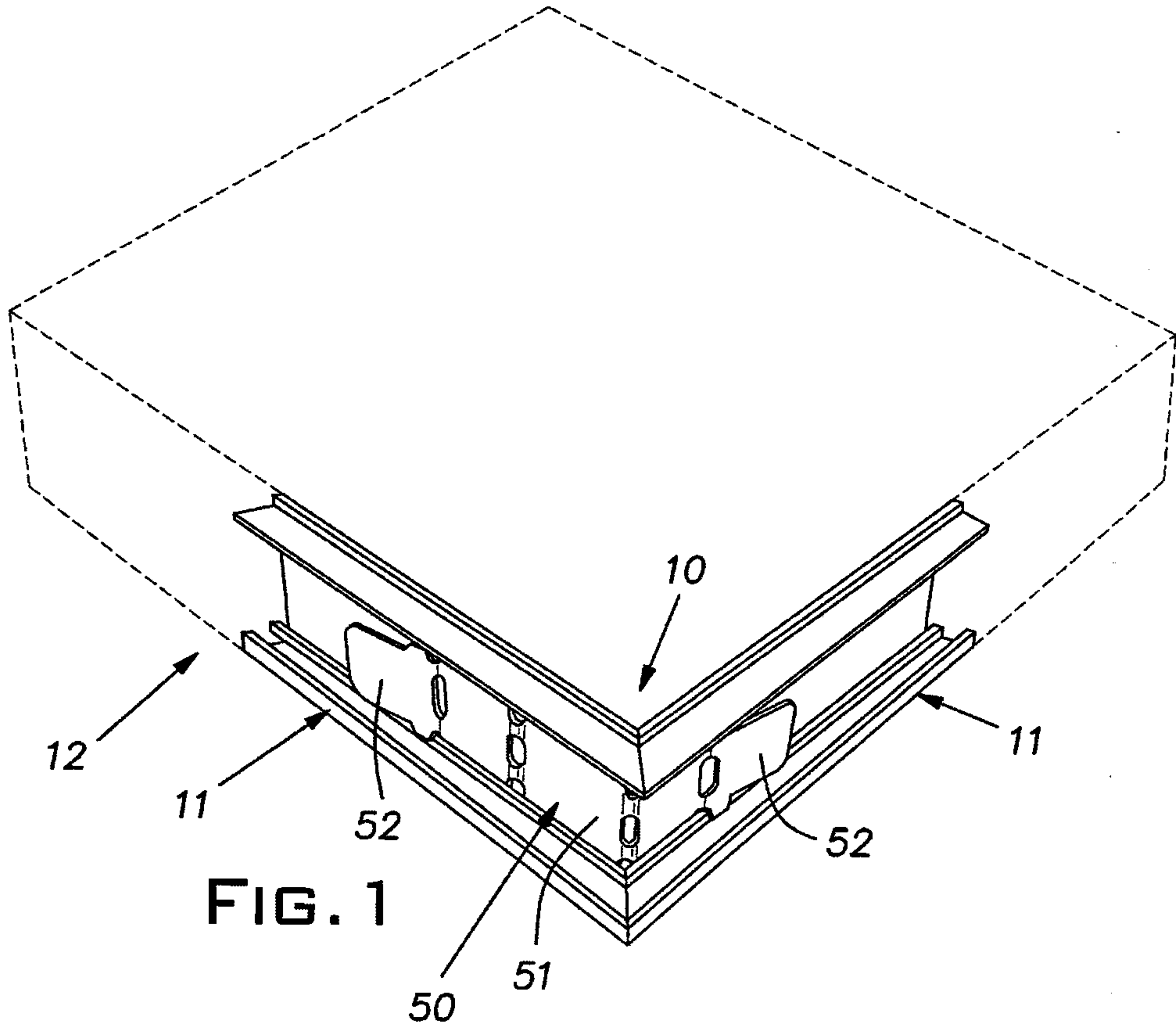

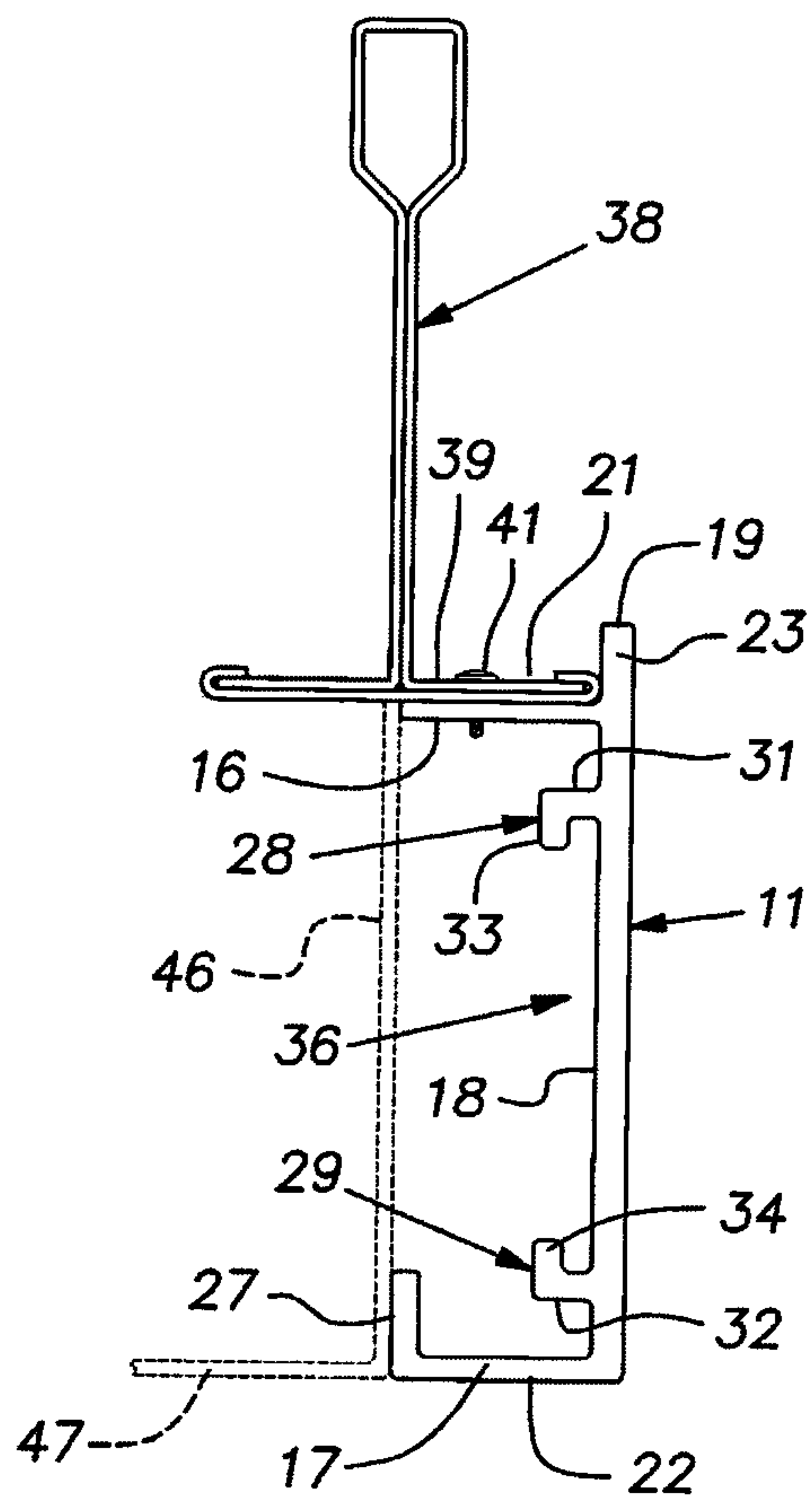

FIG. 3

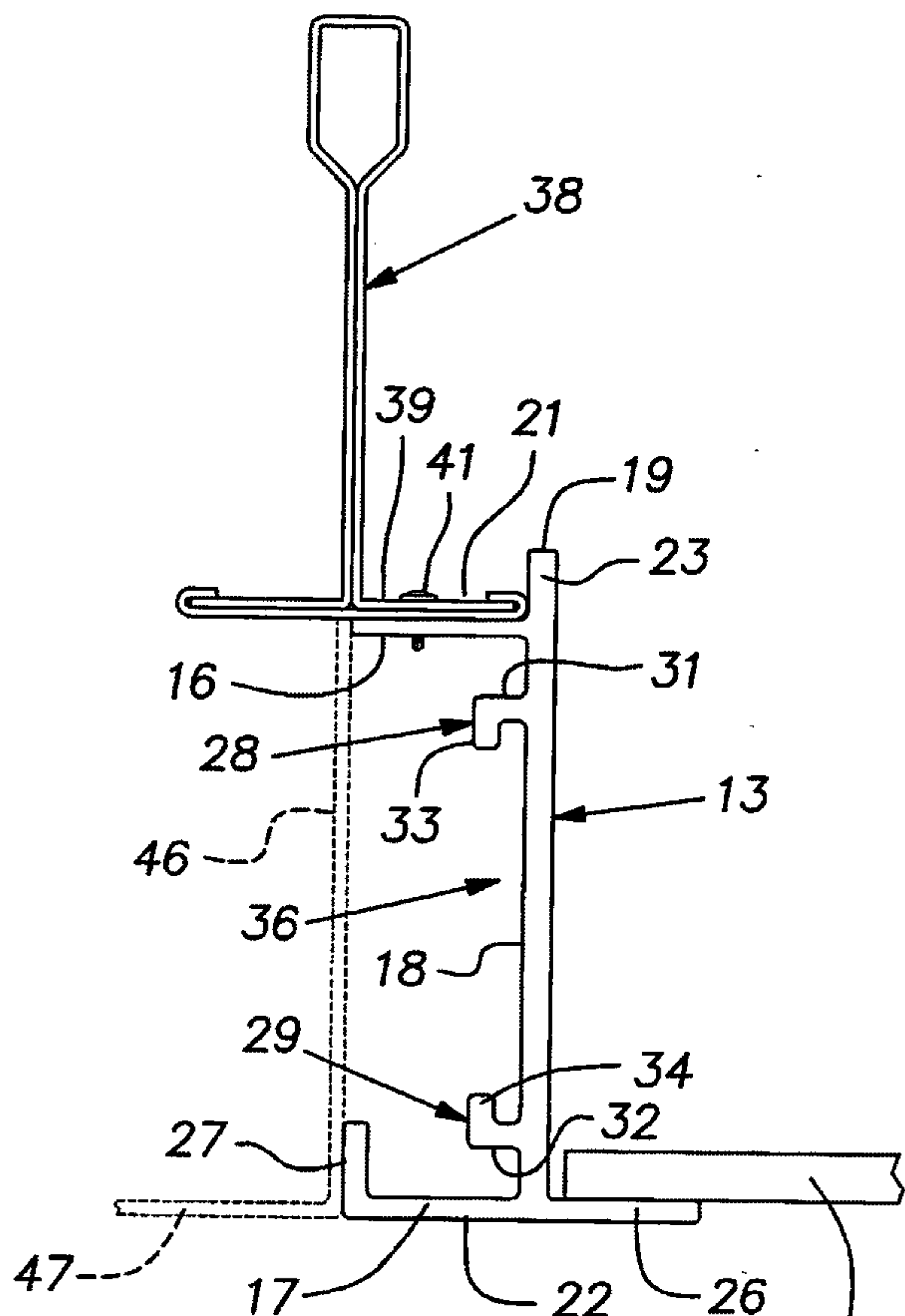

FIG. 4

