

(No Model.)

E. HARRYMAN.
WATER MOTOR.

No. 452,221.

Patented May 12, 1891.

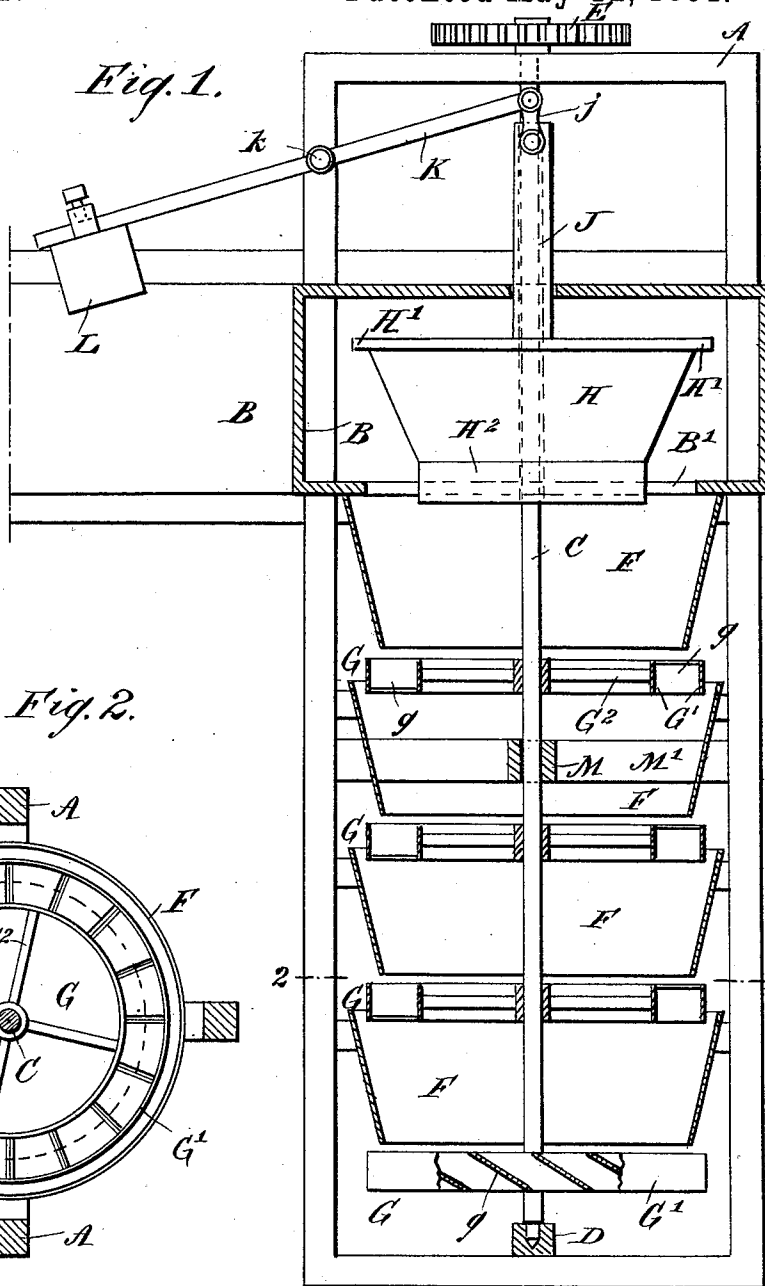
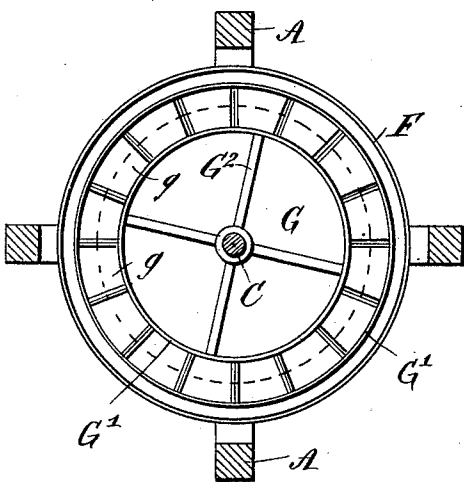

Fig. 2.



WITNESSES:

Down Twitchell
Co. Sedgwick

INVENTOR:

E. Harryman
BY *Munn & Co*
ATTORNEYS

UNITED STATES PATENT OFFICE,

ELEAZAR HARRYMAN, OF JULIAETTA, IDAHO.

WATER-MOTOR.

SPECIFICATION forming part of Letters Patent No. 452,221, dated May 12, 1891.

Application filed September 4, 1890. Serial No. 363,913. (No model.)

To all whom it may concern:

Be it known that I, ELEAZAR HARRYMAN, of Juliaetta, in the county of Latah and State of Idaho, have invented a new and Improved
5 Water-Motor, of which the following is a full, clear, and exact description.

My invention relates to improvements in water-motors. It is well known that with the ordinary form of motor the water which
10 leaves the motor possesses a considerable amount of energy which is wasted; and the object of my invention is to produce a motor whereby substantially the entire energy of the water may be utilized, and also to pro-
15 duce a motor of simple construction, from which power may be easily taken to drive any desired machinery.

To this end my invention consists in certain features of construction and combina-
20 tions of parts, which will be hereinafter described and claimed.

Reference is to be had to the accompanying drawings, forming a part of this specification, in which similar letters of reference indicate
25 corresponding parts in both the figures.

Figure 1 is a broken vertical section of the motor embodying my invention, and Fig. 2 is a horizontal section on the line 2 2 of Fig. 1.

The vertical frame A receives a flume B at
30 its upper portion, through which water is conveyed to operate the motor, and a shaft C extends vertically through the frame, the lower end of the shaft being mounted in a suitable box D, and the upper end of the
35 shaft, which extends above the top of the frame, having a gear-wheel E affixed thereto, although any approved form of gearing or pulley may be substituted.

The part of the flume B which enters the
40 frame A is provided with a circular opening B' through the bottom, and arranged below the opening and supported in the frame A is a circular shield F, the sides of which converge slightly toward the bottom. A wheel
45 G is arranged immediately below the shield F and is fixed to the shaft C, the said wheel having near its outer edge the concentric vertical bands G', and the inner band is connected with the hub of the wheel by suitable
50 spokes G².

The bands G' are of the same width and connected by plates g, which are arranged

diagonally between the bands, so that the lower edge of one plate will be vertically below the upper edge of the next, and it will
55 thus be seen that water falling upon the plates will have a tendency to turn the wheel and the shaft to which it is attached. The shield F is arranged in relation to the wheel G, so that the lower edge of the shield will
60 be above the central portion of the space between the two bands G', but nearer the outer band, and while it is desirable that the plates should be arranged diagonally, as shown, yet they may be given any desired curve or in-
65 clination.

Another shield F is arranged beneath the upper wheel G and another wheel below said shield, and so on, the shields and wheels being arranged alternately one above the other,
70 and the number of wheels and shields will depend upon the head of water to be utilized, the upper shield and wheel being arranged near the top of the water-head and the lower wheel at the bottom. It will thus be seen that
75 the water passing through the upper shield will turn the upper wheel G, and as it passes through the wheel it will be received and directed by the next lower shield upon the next wheel, and so on until it reaches the lower
80 wheel and is discharged, and it will thus be seen that each wheel will give an additional impulse to the shaft C, so that the entire energy of the water is utilized. Each additional wheel receives an impulse due to the
85 energy of the water acquired by falling from the wheel above plus the energy with which it left said wheel.

A conoidal gate H is mounted loosely upon the upper portion of the shaft C and in the
90 flume B, the said gate being adapted to move vertically upon the shaft and to close the opening B' in the flume when it is lowered into said opening. The gate is provided at the top with a rim or flange H', adapted to
95 rest upon the floor of the flume B, and the lower portion H² of the gate is provided with straight sides, so that the water which passes through the flume and against the gate will be prevented by said sides from passing to
100 the central portion of the shield F below the flume, but will be directed against the sides of the shield, and from thence upon the plates g between the bands G' of the wheel G.

A sleeve J encircles the upper portion of the shaft C above the gate II, the lower portion of the sleeve being attached to the gate, and the upper end of the sleeve is pivotally
 5 connected by means of links *j* with a lever K, said lever being pivoted at the point *k* to the frame A and having its outer end provided with a weight L, which serves as a counter-
 10 balance to the gate II, and thus enables the gate to be easily operated by means of the lever K. The shaft C is provided with a central box M, which is supported by the arms M', extending to the sides of the frame A, and it is obvious that any desired number of
 15 boxes may be used.

If desired, the wheels G may be arranged to receive a belt, so that power may be taken from the wheels direct, or the wheels may be provided with cogs or teeth adapted to transmit power through suitable gearing, and in
 20 this case the wheel E at the top of the shaft C may be dispensed with, if desired. It will be observed that the amount of water entering the motor may be regulated by the position of the gate II, and that the wheels and
 25 shields upon the vertical shaft may be placed any desired distance apart.

The operation of the device is as follows: The water entering the flume B flows around
 30 that portion of the flume within the frame A, and passing through the opening B' in the flume is directed to the inclined sides of the shield F, and from thence falls between the bands G' of the wheel G and upon the plates
 35 *g*, thus imparting motion to the wheel and shaft, and passing from thence to the shields and wheels below.

From the foregoing description it will be seen that the water is taken from near the
 40 head and applied in a succession of impulses before its final discharge, thus obtaining more power than can be obtained by a single impulse of the water.

Having thus described my invention, I claim as new and desire to secure by Letters Patent—

1. A water-motor comprising a vertical shaft and inwardly-extending shields encircling the shaft, a wheel fixed to the shaft below each shield, said wheel having vertical
 50 concentric bands near its edge, and plates arranged diagonally between the bands, substantially as described.

2. A water-motor comprising a vertical shaft, a series of inclined shields encircling
 55 the shaft, a series of wheels fixed to the shaft between the shields, said wheels having near their outer edges vertical concentric bands connected by diagonally-arranged plates, and a flume arranged to deliver upon the upper
 60 shield and having a circular opening in the bottom, substantially as described.

3. A water-motor comprising a vertical shaft, a series of inclined shields encircling
 65 the shaft, a series of water-wheels fixed to the shaft between the shields, a flume arranged to deliver upon the upper shield and having a circular opening in the bottom, as shown, and a vertically-movable gate mounted upon the shaft and adapted to close the
 70 opening through the flume, substantially as described.

4. In a water-motor, the combination, with the flume having an opening in the bottom thereof, as shown, and an inclined shield
 75 arranged below the flume and adapted to deliver upon the water-wheel, of the vertically-movable gate having inclined sides, and a laterally-extending flange at the top and the straight-sided lower portion, substantially as
 80 described.

ELEAZAR HARRYMAN.

Witnesses:

L. M. BUTLER,
 JAMES C. TURIDGE.