

LV 10932

①9

LATVIJAS REPUBLIKAS
PATENTU VALDE

①1 LV 10932 B

⑤1 Int.Cl. 5 B01D53/32

Latvijas patents uz izgudrojumu
1995.g. 30.marta Latvijas Republikas likums

①2

Īsziņas

②1	Pieteikuma numurs:	P-93-545	⑦3	Īpašnieks(i):	OY AIRTUNNEL LTD.; Sofianlehdonkatu 9, SF-00610 Helsinki, FI
②2	Pieteikuma datums:	10.06.1993*	⑦2	Izgudrotājs(i):	Veikko ILMASTI (FI)
④1	Pieteikuma publikācijas datums:	20.12.1995	⑦4	Pilnvarotais vai pārstāvis:	Gunārs ROTBERGS, Aģentūra "FORAL", Raiņa bulv.19, Rīga LV-1159, LV
④5	Patenta publikācijas datums:	20.02.1996			
③0	Prioritāte:	893998 25.08.1989 FI			

⑤4 Virsraksts: **Gaisa, dūmgāzu un ekvivalentas vides attīrīšanas paņēmieni un iekārta tā realizēšanai**

⑤7 Kopsavilkums: Piedāvāts gaisa, kurtuvju gāzu un tiem ekvivalentas vides attīrīšanas paņēmieni un iekārta tā realizēšanai. Minēto vidi ievada kanālā vai analogiskā līdzeklī, kur to jonizē. Uzlādētās piemaisījuma daļiņas (7), kuras ir attīrāmajā vidē, pievelkas vienai vai vairākām satvērējvirsmām (2) lādiņu stāvokļa atšķirības rezultātā un nosēžas uz tām. Vidi jonizē ar vienu vai vairākiem jonizējošiem elektrodiem (5), kuri vērsti pret satvērējvirsmu. Attālumu starp jonizējošajiem elektrodiem vai to ekvivalentiem un satvērējvirsmu, tāpat satvērējvirsmas elektrisko lādiņu un uzlādēto piemaisījuma daļiņu stāvokļa atšķirību regulē tā, lai piemaisījuma daļiņas tiektos tieši uz satvērējvirsmu un nosēstos uz tās.

Fig. 2 ilustrē gaisa attīrīšanu kanālā saskaņā ar izgudrojumu.

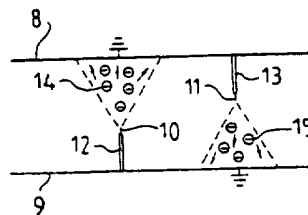

Fig.2

* pieteikums pieņemts ievērojot LR Ministru Padomes 1992.gada 28.februāra lēmumu Nr 72(PSRs pat.piet.Nr. 4830831, iesniegšanas datums 24.08.1990)

IZGUDROJUMA FORMULA

1. Gaisa, dūmgāzu vai ekvivalentas vides attīrīšanas paņēmieni, gaisu, dūmgāzes vai ekvivalentu vidi ievadot kanālā vai analogiskā līdzeklī un jonizējot, kurā, izmantojot lādiņa stāvokļu starpību, gaisā, dūmgāzēs vai ekvivalentā vidē esošās piemaisījumu daļiņas (7, 14, 15, 28, 29, 35, 36) pievelkas vienai vai vairākām saķervirsmām (2, 8, 9, 20, 23, 30, 37), un ierosina daļiņām nosēsties uz minētajām virsmām, pie tam gaisu, dūmgāzes vai ekvivalento vidi jonizē ar vienu vai vairākiem jonizējošiem elektrodiem (5, 10, 11, 21, 24, 25, 31, 32, 38) vai ekvivalentiem līdzekļiem, kuri vērsti uz saķervirsmu, **a t š ķ i r a s** ar to, ka attālumu starp jonizējošo elektrodu vai ekvivalento līdzekli un saķervirsmu, tāpat kā starpību starp saķervirsmas elektriskā lādiņa un uzlādēto piemaisījumu daļiņu stāvokļiem noregulē tā, lai piemaisījumu daļiņas jonu stars aiznestu būtībā tieši uz saķervirsmu un nosēdinātu uz tās.

2. Paņēmieni saskaņā ar 1. punktu, **k a s a t š ķ i r a s** ar to, ka saķervirsmas funkcijas veic kanāla sienas.

3. Iekārta paņēmiena saskaņā ar 1. punktu realizēšanai, kas paredzēta gaisa, dūmgāzu vai ekvivalentas vides attīrīšanai un sastāv no kanāla vai ekvivalenta līdzekļa, kurā ievada gaisu, dūmgāzes vai ekvivalentu vidi, viena vai vairākiem jonizējošiem elementiem gaisa, dūmgāzu vai ekvivalentās vides jonizēšanai, pie tam kanāls vai ekvivalentais līdzeklis apgādāts ar vienu vai vairākām saķervirsmām (2, 8, 9, 20, 23, 30, 37), kuras, pateicoties elektriskā lādiņa stāvokļu starpībai, pievelk uzlādētās piemaisījumu daļiņas (7, 14, 15, 28, 29, 35, 36) no gaisa, dūmgāzēm vai ekvivalentās vides tā, ka daļiņas nosēžas uz minētās virsmas (-ām), un jonizējošais elements ir jonizējošais elektrods, kurš vērsts uz saķervirsmu (5, 10, 11, 21, 24, 25, 31, 32, 38), un to izmanto gaisa, dūmgāzu vai ekvivalentās vides jonizēšanai, **a t š ķ i r a s** ar to, ka attālumu starp jonizējošo elektrodu vai ekvivalento līdzekli un saķervirsmu, tāpat kā starpību starp saķervirsmas elektriskā lādiņa un uzlādēto piemaisījumu daļiņu stāvokļiem noregulēti tā, lai piemaisījumu daļiņas jonu stars aiznestu būtībā tieši uz saķervirsmu un nosēdinātu uz tās.

4. Iekārta saskaņā ar 3. punktu, **k a s a t š ķ i r a s** ar to, ka tai ir tīrīšanas ierīce (16 - 18) saķervirsmu attīrīšanai.

5. Iekārta saskaņā ar 3. vai 4. punktu, kas atšķiras ar to, ka kanāls (20) konstruēts tā, lai attīrošais šķidrums, piemēram, ūdens, varētu iztecēt no kanāla caur izlaides atveri (22) vai ekvivalentu ierīci.

6. Iekārta saskaņā ar jebkuru no 3. - 5. punktiem, kas atšķiras ar to, ka kanālam ir paplašinājums (23), kas ļauj palēnināt caur kanālu plūstošo gaisu, dūmgāzes vai ekvivalento vidi, pie kam paplašinātā daļa apgādāta ar vienu vai vairākiem jonizējošiem elektrodiem.

7. Iekārta saskaņā ar 3. punktu, kas atšķiras ar to, ka kanāls (30) vismaz daļēji izveidots spirālveidīgs.

8. Iekārta saskaņā ar 3. punktu, kas atšķiras ar to, ka attīrīšanas kanāls (37) izvietots gaisa izlaides kanāla (39) iekšpusē.

9. Iekārta saskaņā ar jebkuru no 3. - 8. punktiem, kas atšķiras ar to, ka satur līdzekļus (37 - 41), kuri ražo augstspriegumu jonizējošā elektroda vai ekvivalenta līdzekļa barošanai.

10. Iekārta saskaņā ar 9. punktu, kas atšķiras ar to, ka ietver kontroles signālbloku (42) barošanas padeves pārtraukšanai tajā gadījumā, ja mitrums, temperatūra vai jonizējošā elektroda vai ekvivalenta līdzekļa strāva pārsniedz pieļaujamo robežu.

PROCEDURE AND APPARATUS FOR THE PURIFICATION OF AIR, FLUE GASES OR EQUIVALENT

The present invention concerns a procedure and an apparatus for the purification of air, flue gases or equivalent, in which procedure the air, flue gases or equivalent are directed into a duct or equivalent, in which procedure the air, flue gases or equivalent are ionized, in which procedure charged impurity particles present in the air, flue gases or equivalent are attracted by one or more collector surfaces by virtue of a difference in the states of charge, causing the particles to settle on said surface(s), and in which procedure the air, flue gases or equivalent are ionized by means of one or more ionizing electrodes or equivalent directed at the collector surface.

GB-patent publication 1 238 438 proposes a procedure and an apparatus for the removal of dust particles from the air in a tunnel. In the procedure presented in the publication mentioned, the tunnel is provided with electrodes, to which a high voltage is applied. The electrodes charge the particles in the air in the tunnel by producing an electric field between the interior wall of the tunnel and the electrodes. Thus the charged dust particles are attracted to the interior walls of the tunnel. For the air to be sufficiently purified, it has to be very strongly ionized in order that all particles in the tunnel should be charged and settle when they encounter an interior surface of the tunnel. Moreover, several electrodes and a long tunnel are needed. SE-application publication 8501858-8 proposes a procedure for eliminating or reducing the emissions of SO_x and NO_x .

The object of the present invention is to eliminate the drawbacks of the previously known techniques. The procedure of the invention for the purification of air, flue gases or equivalent is characterized in that the distance between

the ionizing electrode or equivalent and the collector surface as well as the difference between the states of electric charge of the collector surface and the charged impurity particles are so adjusted that the impurity particles present in the air, flue gases or equivalent will be carried by an ion beam essentially directly towards the collector surface and settle on it.

The preferred embodiments of the invention are presented in the other claims.

The invention provides the following advantages over current methods:

Efficient purification even in a short duct. Considerable reduction in energy consumption as compared to current procedures. The need for maintenance is reduced as the collector surfaces can be washed simply with a water jet.

Air can be purified regarding different particle sizes down to pure gases. The invention makes it possible to remove particles as small as 0.005 μm and even smaller.

In the following, the invention is described in greater detail by the aid of examples with reference to the drawings attached, in which

Fig. 1 illustrates air purification in a duct by the procedure of the invention.

Fig. 2 also illustrates air purification in a corridor or duct by the procedure of the invention.

Fig. 3 illustrates the cleaning of a wall acting as a collector surface.

Fig. 4 shows a tube used for air purification.

Fig. 5 shows an expanded tube used for air purification.

Fig. 6 shows a spiral tube.

Fig. 8 shows a structure for air intake and air outlet.

Fig. 1 presents a duct which has side walls 1 and 2, a ceiling 3 and a floor 4. The fresh air supplied into a building or the air to be re-circulated is directed into the duct for removal of impurity particles. For purification, the air is ionized by means of an ionizing electrode 5 mounted on a bracket 6 and connected with a cable to a voltage supply unit, which will be described later. The ionizing electrode 5 is directed at the opposite side wall 2, which is earthed and acts as a particle-collecting surface. The voltage applied to the ionizing electrode 5, which is of the order of 100 - 250 kV, and the distance between the ionizing electrode and the side wall are so adjusted that a conical ion beam or ion jet as indicated by the broken lines is produced. With this arrangement, the (negatively) charged impurity particles 7 will move directly to the side wall 2 and settle on it due to the difference in electric charge between the particles and the wall. The ion jet can be felt near the wall as a cool ion current. The distance between the ionizing electrode and the collecting wall is typically 100 - 1000 mm.

Fig. 2 shows a top view of a duct with earthed side walls 8 and 9 and two ionizing electrodes 10 and 11 mounted on brackets 12 and 13. This arrangement allows a more efficient purification of the air as the first electrode 10 produces a conical ion beam causing impurity particles 14 to move towards wall 8 and settle on it while the second electrode 11 produces an ion beam causing impurity particles 15 to move to the opposite wall 9, so that the air is efficiently purified over the whole sectional area of the duct.

Fig. 3 illustrates the cleaning of the collector surface 2 using a water jet. The water is sprayed onto the surface through a nozzle 16, to which it is supplied via a hose 17 from a container 18. The duct floor 19 is V-shaped, so that the water is gathered in the middle of the floor, from where it can be directed further e.g. into a drain.

Fig. 4 shows a tubular purification duct 20 with ionizing electrodes 21. The duct has a curved shape such that the cleaning water will flow out through an exit opening 22 as indicated by the arrows.

Fig. 5 shows a tubular purification duct 22 provided with an expansion 23 to retard the flow of air through it, the walls of the expanded part acting as collecting surfaces. The expanded part is provided with ionizing electrodes 24 and 25 mounted on brackets 26 and 27 on opposite walls. The impurity particles 28 and 29 drift towards the collecting surfaces as explained above. Fig. 6 presents a spiral tube 30 with ionizing electrodes 31 and 32 mounted on brackets 33 and 34. The impurity particles settle on the earthed wall of the tube 30. The water used for cleaning the spiral tube exits through the lower end as indicated by the arrows.

Fig. 7 shows a diagram of the power supply unit, which supplies a voltage to the ionizing electrodes. The unit comprises high-voltage and low-voltage units 37 and 38, which are fed by the mains voltage V_{in} , e.g. 220 V. The high-voltage and low-voltage units control a pulse-width modulator 39. The output of the pulse-width modulator is connected to the primary side of a high-voltage transformer 40, and the transformer output is connected to a high-voltage cascade 41, whose output voltage V_{out} is applied to the ionizing electrodes. The mains voltage also feeds the power supply 43 of a microprocessor 42. Connected to the microprocessor are sensors for the ionizing current, duct temperature and humidity and for a

solenoid controlling the spraying of wash water through the nozzle. The sensors give an alarm in the form of a signal light in an alarm unit 44 and also an inhibit signal to the modulator, preventing the supply of voltage. The output voltage V_{out} is adjusted by means of a regulating element 45.

Fig. 8 presents a tubular duct 37 for intake air, provided with an ionizing electrode 38 in the manner described above. The purification duct 37 is surrounded by an exit air duct 39, so that the action of the structure resembles that of a heat exchanger.

It is obvious to a person skilled in the art that different embodiments of the invention are not restricted to the examples described above, but that they may instead be varied within the scope of the following claims. Instead of earthed collector surfaces, it is also possible to use collector surfaces having a charge of opposite sign in relation to the ions.

CLAIMS

1. Procedure for the purification of air, flue gases or equivalent, in which procedure the air, flue gases or equivalent are directed into a duct or equivalent, in which procedure the air, flue gases or equivalent are ionized, in which procedure charged impurity particles (7,14,15,28,29,35,36) present in the air, flue gases or equivalent are attracted by one or more collector surfaces (2,8,9,20,23,30,37) by virtue of a difference in the states of charge, causing the particles to settle on said surface, and in which procedure the air, flue gases or equivalent are ionized by means of one or more ionizing electrodes (5,10,11,21,24,25,31,32,38) or equivalent directed at the collector surface, characterized in that the distance between the ionizing electrode or equivalent and the collector surface as well as the difference between the states of electric charge of the collector surface and the charged impurity particles are so adjusted that the impurity particles will be carried by an ion beam essentially directly towards the collector surface and settle on it.
2. Procedure according to claim 1, characterized in that the walls of the duct act as collector surfaces.
3. Apparatus implementing the procedure of claim 1 for the purification of air, flue gases or equivalent, comprising a duct or equivalent into which the air, flue gases or equivalent are directed, one or more ionizing elements for the ionization of the air, flue gases or equivalent, the duct or equivalent being provided with one or more collector surfaces (2,8,9,20,23,30,37) attracting charged impurity particles (7,14,15,28,29,35,36) by virtue of a difference in the states of electric charge from the air, flue gases or equivalent so that the particles will settle on said

surface(s), the ionizing element being an ionizing electrode which is directed at a collector surface (5,10,11,21,24,25,31,32,38) and used to ionize the air, flue gases or equivalent, characterized in that the distance between the ionizing electrode or equivalent and the collector surface as well as the difference between the states of electric charge of the collector surface and the charged impurity particles are so adjusted that the impurity particles will be carried by an ion beam essentially directly towards the collector surface and settle on it.

4. Apparatus according to claim 3, characterized in that it is provided with cleaning equipment (16-18) for the cleaning of the collector surface.

5. Apparatus according to claim 3 or 4, characterized in that the duct 20 is so constructed that the cleaning fluid, e.g. water, is allowed to flow out of the duct through an exit opening (22) or equivalent.

6. Apparatus according to any one of claims 3 - 5, characterized in that the duct is provided with an expansion (23) to retard the flow of air, flue gases or equivalent through it, the expanded part being provided with one or more ionizing electrodes.

7. Apparatus according to claim 3, characterized in that the duct 30 is at least partially spiral-shaped.

8. Apparatus according to claim 3, characterized in that the purification duct (37) is placed inside an exit air duct (39).

9. Apparatus according to any one of claims 3 - 8, characterized in that it comprises means

(37-41) for producing a high voltage supplying the ionizing electrode or equivalent.

10. Apparatus according to claim 9, characterized in that it comprises a supervision unit (42) for interrupting the supply of power when the humidity, temperature or the current of the ionizing electrode or equivalent is out of the permitted range.

(57) ABSTRACT OF DISCLOSURE

Procedure and apparatus for the purification of air, flue gases or equivalent, in which procedure the air, flue gases or equivalent are directed into a duct or equivalent, in which procedure the air, flue gases or equivalent are ionized, and in which procedure the charged impurity particles (7) present in the air, flue gases or equivalent are attracted by one or more collector surfaces (2) by virtue of a difference in the states of charge, causing the particles to settle on said surface. The air, flue gases or equivalent are ionized by means of one or more ionizing electrodes (5) directed at a collector surface. The distance between the ionizing electrode or equivalent and the collector surface as well as the difference between the states of electric charge of the collector surface and the charged impurity particles are so adjusted that the impurity particles will be carried by an ion beam essentially directly towards the collector surface and settle on it.

Fig.1.

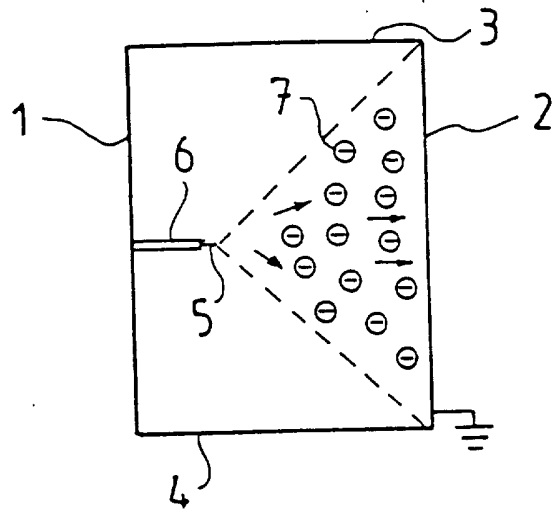

Fig.1

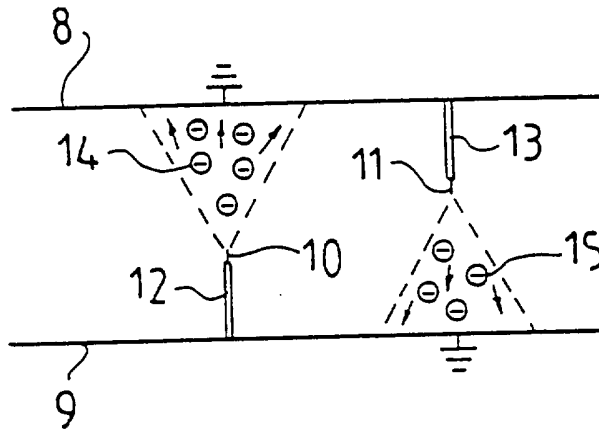

Fig.2

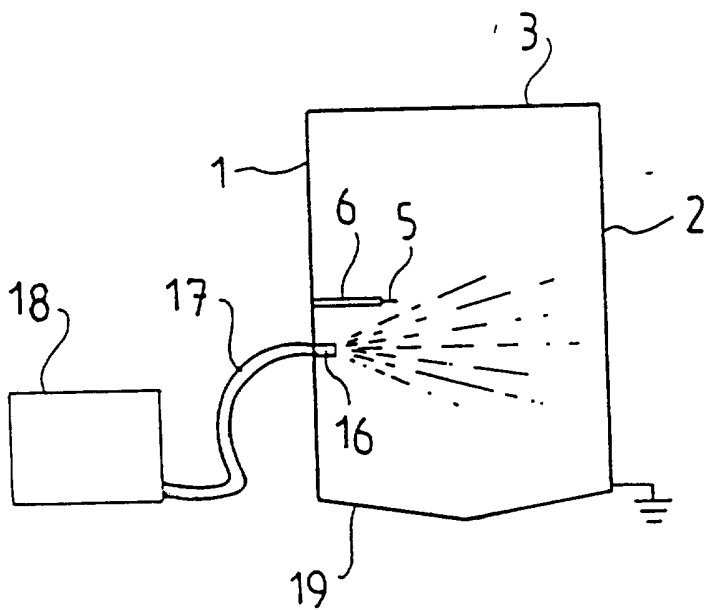

Fig.3

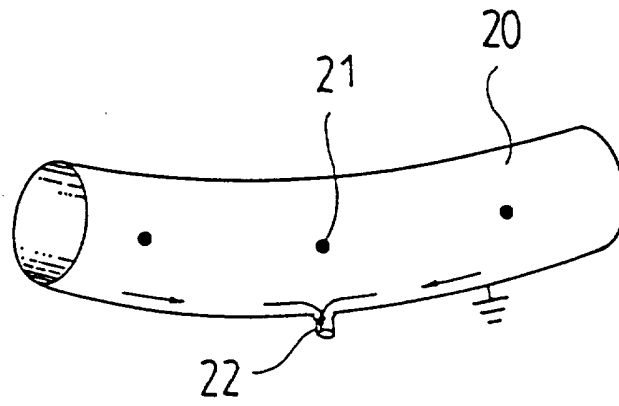

Fig.4

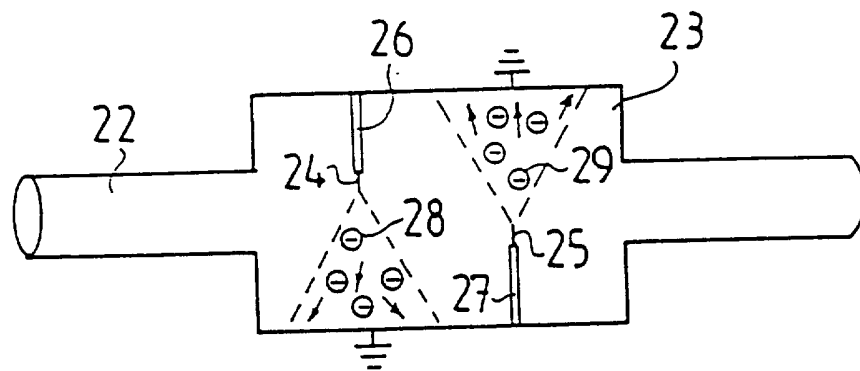

Fig.5

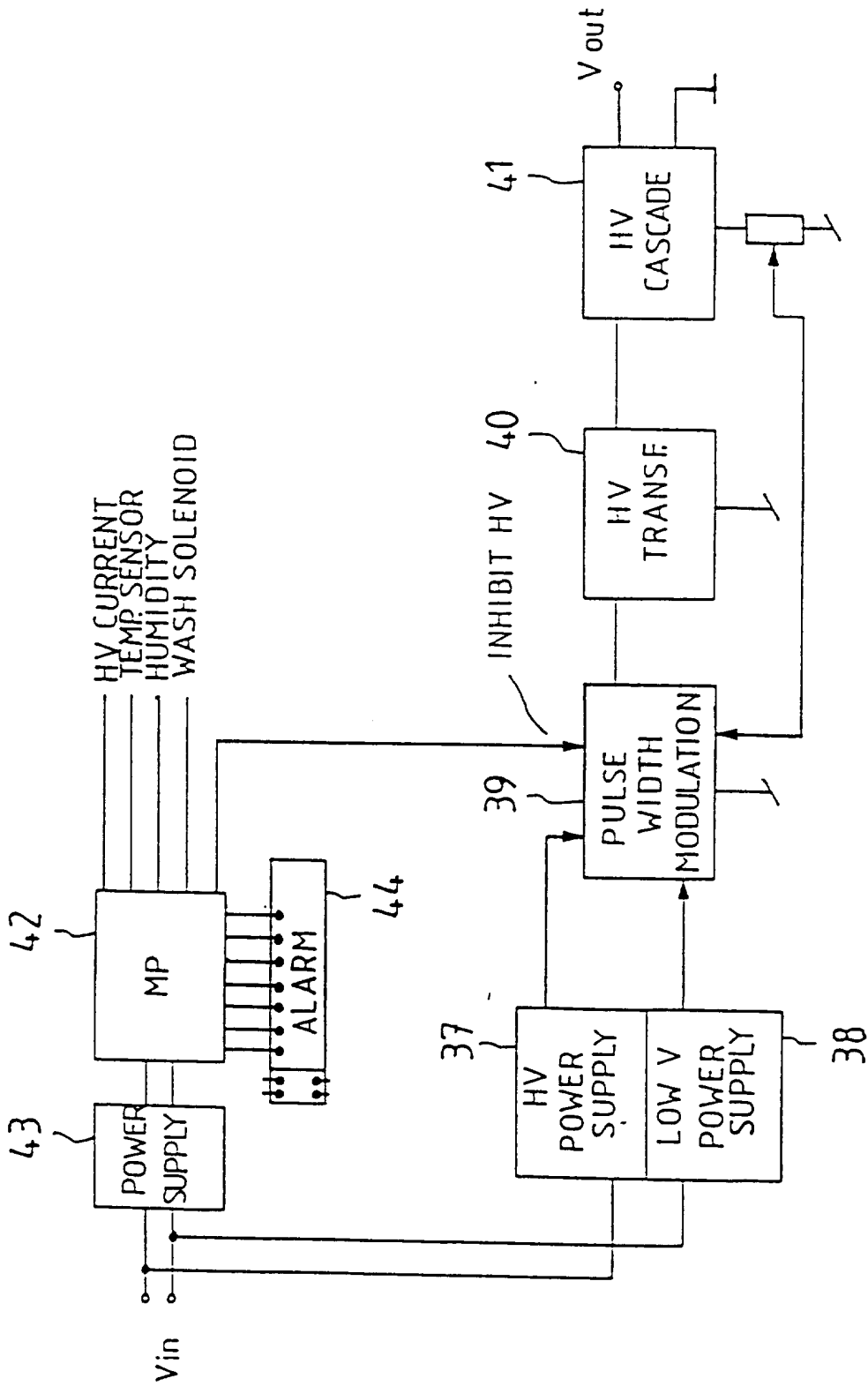

Fig.7

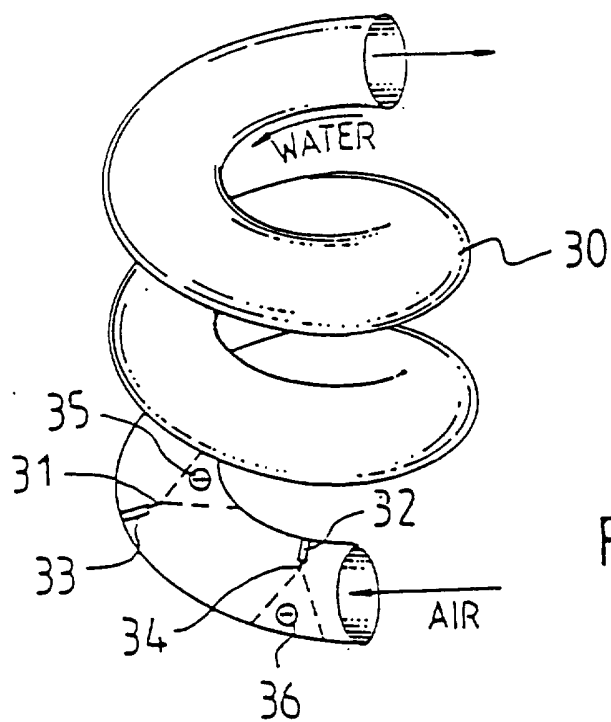

Fig. 6

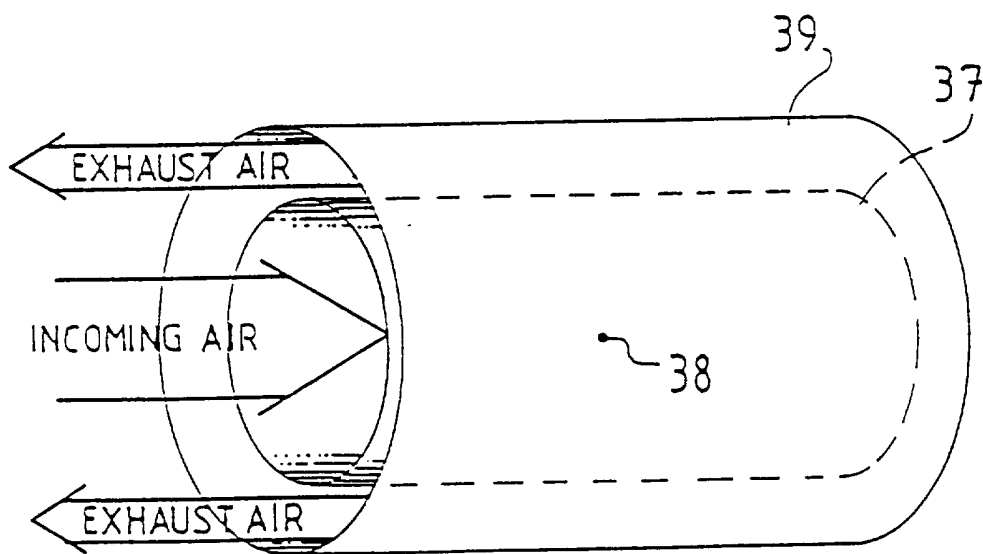

Fig. 8